

FASTWAY
Trailer Products®



Product Catalog

Fastway Trailer Products - Faster, Easier.™



Table of Contents

Our Family Cares About Yours	3
Fastway Sales Team and Regions	4
e2 Hitches	5
e2 Hitch Parts Breakdown	8
Flash Aluminum Ball Mounts	11
Flip Automatic Jack Foot & Flip Jack Packs	19
Zip Trailer Breakaway Cable	21
ONEstep Wheel Chock	23
Fastway Locks.	25
Towing Accessories	27
Marketing Material	29

Our Family Cares About Yours

At Fastway® Trailer Products, we provide the best towing products on the market. Our greatest success is to hear how our products positively affect the way our customers work and play. Each day we come to work, we focus on making sure our gear saves you time and effort and is strong and dependable.

Our innovative trailer accessories have been featured in Popular Mechanics and have won national awards. Revolutionary engineering and quality materials mean you get a product that is built to last. The result: a faster and easier way to get each job done - no matter what the task.

Whether you tow for work or play, you can feel secure knowing that people with families just like yours care about the strength and reliability of every product in our Fastway line.





Sales Team

Sales Regions

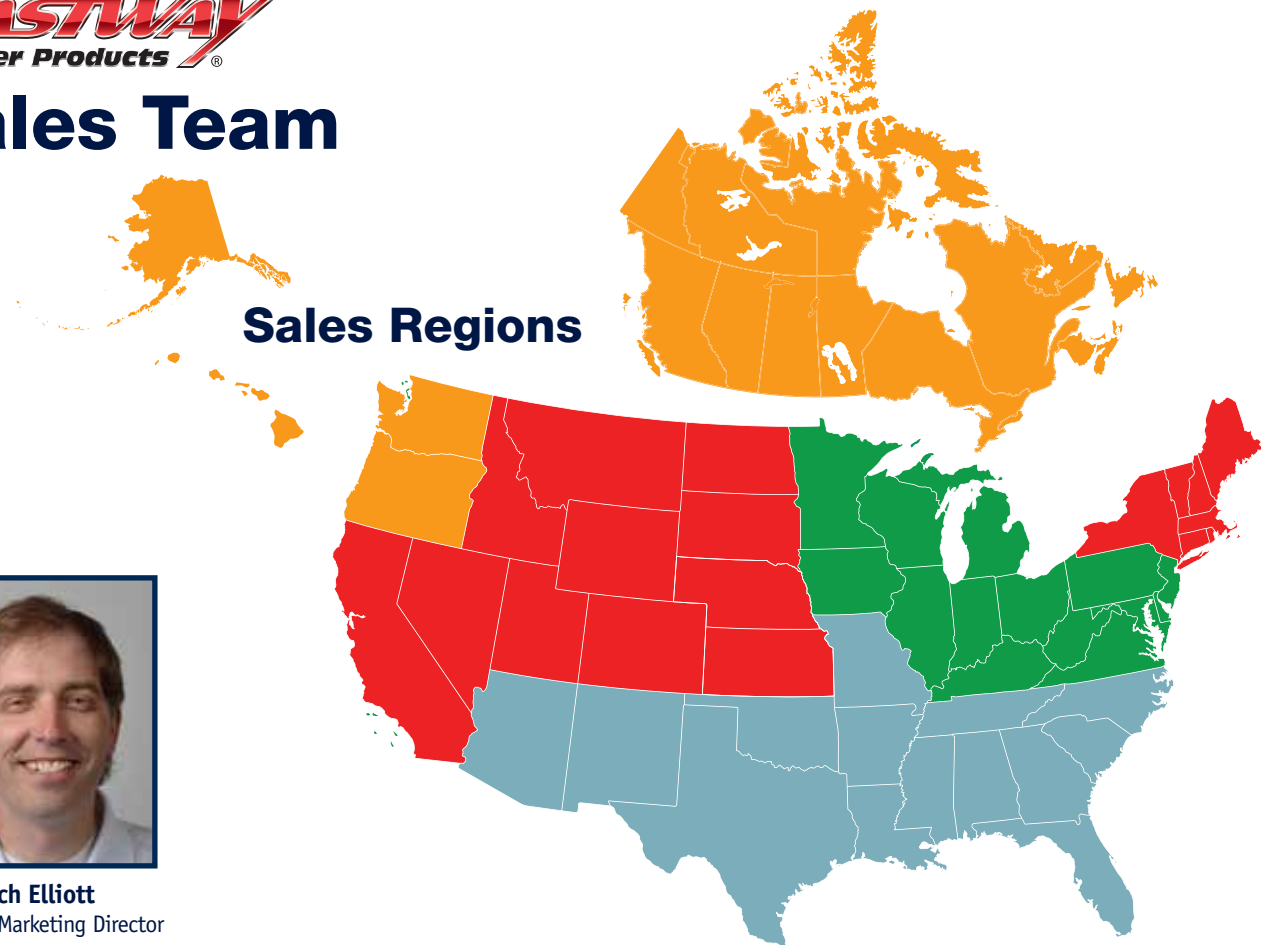

Rich Elliott
Sales and Marketing Director



Kim Dewsnap
RV Sales Account Manager



Rob Stratton
RV Sales Account Manager



Deven McCann
RV Sales Account Manager



Pat Hunt
RV Sales Account Manager



Mike Flygare
ATO Sales Manager



Todd Munford
Inside RV Sales



Tyler Ferre
Inside RV Sales



Jason Binks
Inside Sales Manager



Matt Darrington
ATO Sales Account Manager



Trevor Millar
ATO Sales Account Manager



Fastway e2™ Hitch

Fastway Trailer Products - Faster, Easier.™

e2 The Fast and Easy Towing Solution



LESS HASSLE – LESS STRESS – SAFER TOWING

For the best and safest towing experience, you need the e2™ hitch, giving you faster and easier weight distribution and sway control.

Old-fashioned chain-style hitches don't provide built-in sway control, and add-on sway controls are a hassle to remove when backing up and making tight turns. The e2 hitch's rigid brackets give you built-in sway control, so you get on the road faster and enjoy your drive.

When a trailer is coupled to a tow vehicle, the added weight can cause the vehicle to teeter-totter over the rear axle. The front of the tow vehicle raises

and the rear sinks. This causes a dangerous towing situation because less weight on the front axle results in a loss of steering and braking control. The e2 hitch changes the way the tow vehicle and trailer couple together to provide excellent built-in sway control. It creates a bridge between the trailer and vehicle, helping them work together like one unit instead of two, distributing weight evenly to the axles of both vehicles. With an e2 hitch, your front wheels will stay firmly on the ground and your trailer will track behind you, providing more control and an enjoyable trip.



1

WEIGHT DISTRIBUTION (WD)

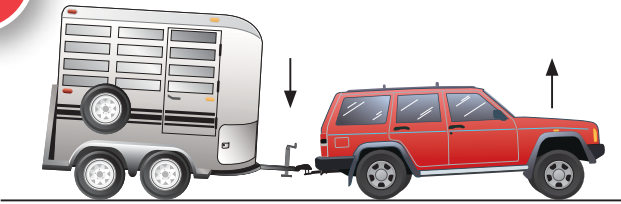

Without Weight Distribution

Towing without a weight distribution hitch can cause a dangerous loss of steering and braking control.

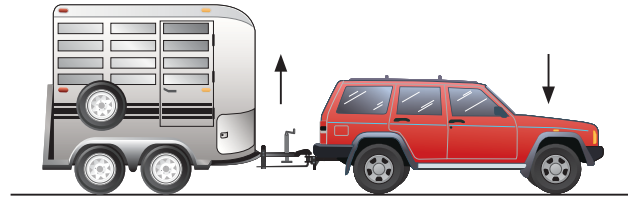

With e2 Hitch Weight Distribution

With the e2 hitch your trailer's tongue weight is more evenly distributed across both axles of your tow vehicle.

Benefits:

- Better steering control
- Better braking control
- More comfortable ride
- Higher towing capacity
- Less wear and stress on the tow vehicle and trailer
- Safer than towing with a ball mount

2

SWAY CONTROL (SC)

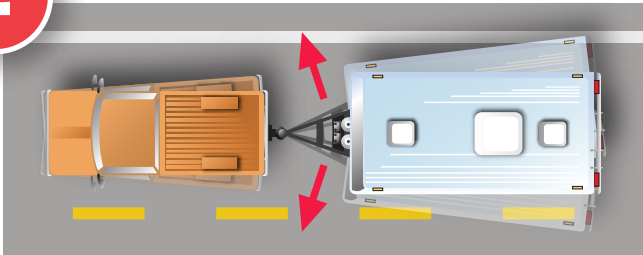

No Sway Control

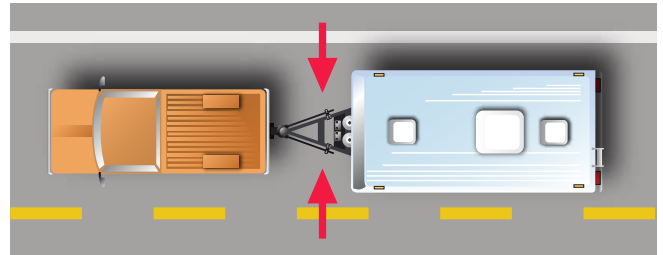

e2 Sway Control

Causes of Sway:

- Crosswinds
- Passing semi trucks
- Road conditions
- Towing speeds
- Tow vehicle ratings exceeded
- Improper loading / load shifting

3

THE e2 SOLUTION



Available in a trunnion or round-bar style.

e2, the complete solution

- Sway control and weight distribution in one system
- Comes in trunnion and round bar models
- Ten year warranty
- Built-in sway control
- No add-on hassles
- No backing or turning restrictions

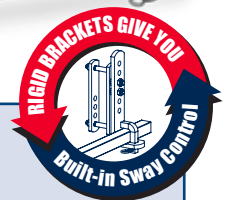

Purchase the e2 hitch, the fast and easy towing solution.

Fastway® e2 Hitch Parts Breakdown

e2 6-12K Trunnion

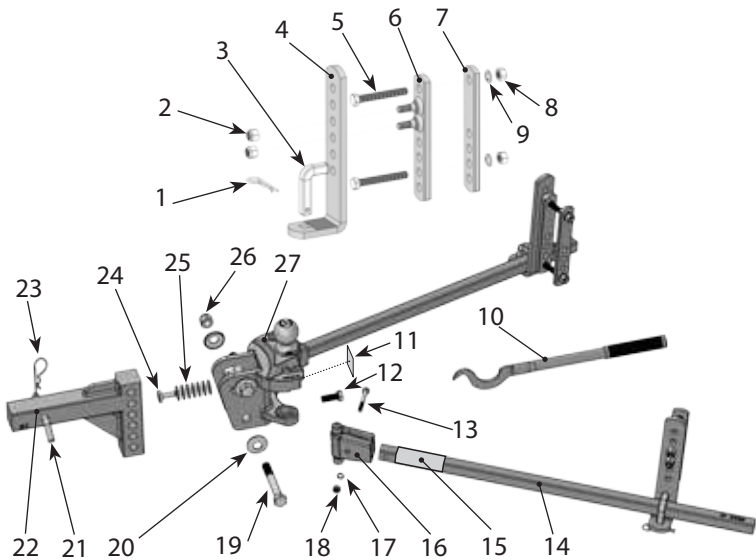

e2 4.5K Trunnion

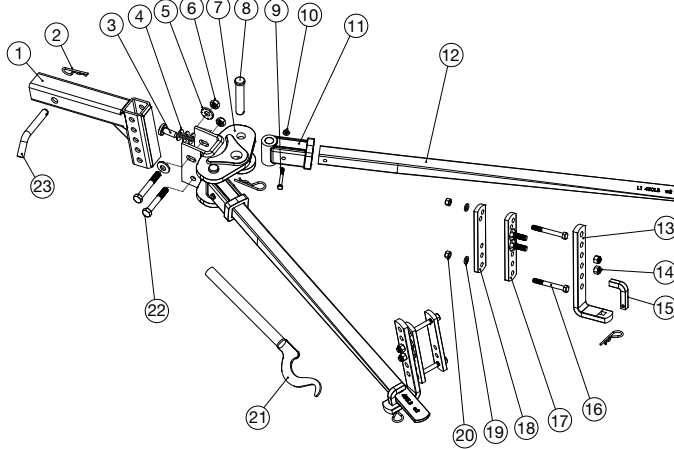

Item #	Mfg. Part #	Description	Qty.
1	92-04-9208	L-Pin Clip	2
2	90-04-9286	1/2" Nylock Nut	4
3	92-03-9205	L-Pin	2
4	93-02-5150	L-Bracket	2
5	93-02-9270	1/2" x 4" Bolt - Grade 5	4
6	93-02-5350	Studded Outside Link Plate	2
7	93-02-5200	Inside Link Plate	2
8	92-04-9228	1/2" Nut	4
9	92-04-9290	1/2" Lock Washer	4
10	92-00-6000	Snap-up Lever	1
11	BD092-WH	Trunnion Head Attn. Sticker	1
12	92-03-9700	5/8" Angle Set Bolt	1
13‡	92-04-9615	10mm Hex Bolt	2
14+*	92-02-0699	6,000 lb. Spring Arm (single)	2
	92-02-0899	8,000 lb. Spring Arm (single)	
	92-02-1099	10,000 lb. Spring Arm (single)	
	92-02-1299	12,000 lb. Spring Arm (single)	
15	BD092-WS	Arm Warning Sticker	2
16‡	92-02-0644	6K Trunnion Knuckle	2
	92-02-0844	8K Trunnion Knuckle	
	92-02-1044	10K Trunnion Knuckle	
	92-02-1244	12K Trunnion Knuckle	
17‡	92-04-9620	10mm Lock Washer	2
18‡	92-04-9216	10mm Nylock Nut	2
19	92-04-9635	3/4-10 x 5" Grade 5 Bolt	2
20	92-04-9645	3/4" Conical Toothed Washer	4
21	92-04-9625	Hitch Pin	1
22	92-02-4100	1/2" Drop x 6" Rise Adj. Shank	1
23	92-04-9630	Hitch Pin Clip	1
24	92-04-9650	Spacer Rivet	1
25	92-04-9655	Spacer Washers	7
26	92-04-9640	3/4" Nylock Nut	2
27**	92-02-1255	Trunnion Hitch Head	1
NS	BD092	e2™ Trunnion Instruction Manual	1

Item #	Mfg. Part #	Description	Qty.
1	92-02-4141	Adjustable Shank	1
2	92-04-9705	Hairpin Cotter Pin	5
3	92-04-9710	Spacer Rivet	1
4	92-04-9110	1/2" Hardened Flat Washer	3
5	92-04-9721	1/2" Conical Toothed Washer	2
6	92-04-9732	1/2" - 13 Lock Nut	2
7	92-02-0410	Hitch Head	1
8	92-04-9743	3/4" X 4" Clevis Pin	2
9	92-04-9754	1/4"-20 X 2-1/4" Hex Bolt Grade 5	2
10	92-04-9765	1/4"-20 Flanged Locknut	2
11	92-02-0444	Trunnion Knuckle	2
12	92-02-0499	Spring Arm	2
13	92-02-5140	L-Bracket	2
14	92-03-9486	7/16"-14 Nylock Nut Grade 5	4
15	92-03-9460	L-Pin	2
16	92-03-9470	3/8"-16 X 3-1/2" Hex Bolt Grade 5	4
17	92-02-5354	Outside Link Plate	2
18	92-02-5240	Inside Link Plate	2
19	92-03-9490	3/8" Split Lock Washer	4
20	92-03-9475	3/8"-16 Nut Grade 5	4
21	92-02-6040	Snap-up Lever	1
22	92-04-9787	1/2"-13 X 3-1/2" Hex Bolt Grade 8	2
23	92-04-9700	Hitch Pin	1

* Hitch contains two (2) matched spring arms. See stickers for model # and capacity.
 ** Hitch contains one (1) head rated as indicated on box ends.
 ‡ Comes pre-assembled as one unit
 NS Not Shown



e2 6-10K Round Bar

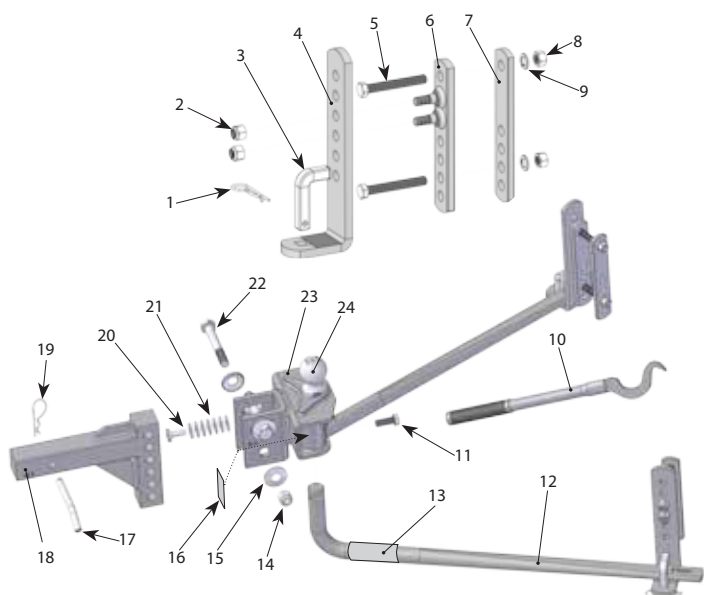

e2 Trunnion Hitches

Part #	Description
92-00-0450	450/4,500 lb.
92-00-0600	600/6,000 lb.
92-00-0800	800/8,000 lb.
92-00-1000	1,000/10,000 lb.
92-00-1033	1,000/10,000 lb. No shank model
92-00-1200	1,200/12,000 lb.
92-00-1065	1,000/10,000 lb. Hitch ball installed



e2 Round Bar Hitches

Part #	Description
94-00-0600	600/6,000 lb.
94-00-0800	800/8,000 lb.
94-00-1000	1,000/10,000 lb.
94-00-1033	1,000/10,000 lb. No shank model
94-00-1061	1,000/10,000 lb. Hitch ball installed

Item #	Mfg. Part #	Description	Qty.
1	92-04-9208	L-Pin Clip	2
2	93-04-9285	1/2" Nylock Nut	4
3	92-03-9205	L-Pin	2
4	93-02-5150	L-Bracket	2
5	93-02-9270	1/2" x 4" Bolt - Grade 5	4
6	93-02-5350	Studded Outside Link Plate	2
7	93-02-5200	Inside Link Plate	2
8	92-04-9228	1/2" Nut	4
9	92-04-9290	1/2" Lock Washer	4
10	92-00-6000	Snap-up Lever	1
11	92-03-9700	5/8" Angle Set Bolt	1
12*	94-02-0699	6,000 lb. Spring Arm (single)	2*
	94-02-0899	8,000 lb. Spring Arm (single)	
	94-02-1099	10,000 lb. Spring Arm (single)	
13	BD094-WS	Arm Sticker	2
14	92-04-9640	3/4" Nylock Nut	2
15	92-04-9645	3/4" Conical Toothed Washer	4
16	BD094-AH	Warning Sticker	1
17	92-04-9625	Hitch Pin	1
18	92-02-4100	2-1/2" Drop x 5-1/2" Rise Adj. Shank	1
19	92-04-9630	Hitch Pin Clip	1
20	92-04-9650	Spacer Rivet	1
21	92-04-9655	Spacer Washers	7
22	92-04-9635	3/4-10 x 5" Grade 5 Bolt	2
23**	94-02-1055	e2 Round Bar Hitch Head	1
24‡		Hitch Ball	
NS	BD094	e2 Round Bar Instruction Manual	1

* Hitch contains two (2) matched spring arms. See stickers for model # and capacity.
 ** Hitch contains one (1) head rated as indicated on box.
 ‡ Hitch ball NOT included except model 94-00-1061.
 NS Not Shown



e2 Specialty Shanks

Part #	Round Bar	Trunnion
92-02-4100	2.5" drop x 5.5" rise x 12" adj.	.5" drop x 6" rise x 12" adj.
92-02-4213	4" drop x 7.5" rise x 12" adj.	2" drop x 8" rise x 12" adj.
92-02-4214	6" drop x 9" rise x 12" adj.	4" drop x 9.5" rise x 12" adj.
92-02-4315	8.5" drop x 12" rise x 12" adj.	6.5" drop x 12.5" rise x 12" adj.

Fastway e2 Hitches vs. Air Suspension



Airbags are great, but they are not a replacement for a weight-distribution hitch (WDH) like the e2. When installed properly, the e2 hitch has the following benefits:

1. It improves front axle steering and braking control while towing.
2. It reduces sag caused by the trailer's tongue weight.
3. It provides more stability when encountering cross winds.

Like an airbag, a WDH will raise the back of the tow vehicle, reducing some of the sag caused by the trailer's tongue weight. The way a WDH raises the rear of the truck is key – it uses torsion to force the front axle of the tow vehicle to carry more of the trailer's tongue weight.

Without shifting some of the tongue weight to the front axle, you may have problems in a fast stop or emergency maneuver. When you brake hard, the weight of the trailer shifts forward and pushes down on the hitch ball harder than normal, which causes the truck to lose front wheel traction. When that happens, you can lose steering and braking ability.

A WDH resists the trailer's nose-dive, and keeps the trailer's tongue weight transferred forward. By using airbags instead of a WDH, in the same panic stop as above, the trailer weight will shift forward, pushing down on the hitch ball. The hitch will then push down on the rear of the truck. Since the airbags are resisting that downward force (at the axle), they become a pivot point, and the front end can get light very quickly. This can all be avoided by using the e2, which will help keep your front wheels on the ground.

When you are passing semi trucks or encountering crosswind, an airbag suspension system provides zero sway control. With the e2 hitch, you have two points of sway control, in addition to weight-distribution, providing safety and security for both your trailer and the important cargo sitting next to you.





FLASH™

Fastway Flash™ Ball Mounts

Fastway Trailer Products - Faster, Easier.™

FLASH

Introducing Flash - the fastest, easiest, and best-looking ball mounts on the market.

Flash™ ball mounts are the best looking, strongest, and highest quality aluminum ball mounts on the market. When you buy Flash, you buy American-made quality, backed by a company with over 70 years of experience building the safest towing products on the road. Flash ball mount locks work better, the finish is nicer, and the mechanisms are smoother than other ball mounts, making it easy to quickly switch between trailers and get on the road.



ALBM series
Integrated dual lock system provides ultimate security and convenience



STBM series
Quietest anti-rattle ball mount you can buy



E series™
Lightning quick adjustments and stunning good looks

NEW!
E series HD™
Built to tow your heaviest trailers and fit your 2½" receiver



LBM series
Most secure fixed-height ball mount

BM series
Only standard ball mount with Flash hand-polished shine



FLASH



ALBM series

(Adjustable Locking Ball Mount)

The ALBM gives you lightning-quick adjustments, maximum theft protection, and stunning good looks. With integrated locks, you know your ball mount is secure on your truck, and the dual locking hitch balls make towing different trailers a snap. With a gorgeous, hand polished finish and beautiful engineering, the ALBM is top-of-the line in design and function.



ALBM features:

- Integrated dual lock system - eliminates the need for separate locking hitch and height-adjustment pins
- Strong stainless steel integrated lock pins for maximum theft protection
- Aircraft-grade aluminum and stainless steel construction for corrosion resistance and outstanding performance
- 1,000 lb. max tongue wt. / 10,000 lb. max trailer wt.
- Easy access front-facing locks
- Hand polished mirror finish, making your truck look its best
- Limited one year warranty
- Made in the USA

ALBM options:

- Dual hitch balls (1-7/8" and 2" combo or 2" and 2-5/16" combo)
- Chrome plated or solid stainless steel hitch balls
- Stainless tri-ball system includes all three hitch ball sizes
- Models available to fit 2-1/2" receivers

ALBM models:*

	4" / 5" drop/rise	6" / 7" drop/rise	8" / 9" drop/rise	10" / 11" drop/rise
Chrome Balls 2" & 2-5/16" 2" Shank	DT-ALBM6400	DT-ALBM6600	DT-ALBM6800	DT-ALBM7000
Chrome Balls 2" & 2-5/16" 2½" Shank	DT-ALBM6425	DT-ALBM6625	DT-ALBM6825	DT-ALBM7025



STBM series

(Adjustable Anti-rattle Ball Mount)

If you don't like ball mount rattle, you will love the STBM. It eliminates hitch noise, making it the quietest ball mount on the market. Its sleek design and hand-polished aluminum will get your truck noticed, and its adjustable height and dual hitch ball make it an excellent choice for towing multiple trailers. Roll down your windows, because it's so quiet you will forget it is on your truck.



STBM features:

- The best anti-rattle system available for the quietest ride
- Aircraft-grade aluminum and stainless steel construction for corrosion resistance and outstanding performance
- 1,000 lb. max tongue wt. / 10,000 lb. max trailer wt.
- Anti-theft hex key adjustment (key included)
- Limited one year warranty
- Made in the USA

STBM options:

- Dual hitch balls (1-7/8" and 2" combo or 2" and 2-5/16" combo)
- Chrome plated or solid stainless steel hitch balls
- Stainless tri-ball system includes all three hitch ball sizes
- Models available to fit 2-1/2" receivers

STBM models:*

	4" / 5" drop/rise	6" / 7" drop/rise	8" / 9" drop/rise	10" / 11" drop/rise
Chrome Balls 2" & 2-5/16" 2" Shank	DT-STBM6400	DT-STBM6600	DT-STBM6800	DT-STBM7000
Chrome Balls 2" & 2-5/16" 2½" Shank	DT-STBM6425	DT-STBM6625	DT-STBM6825	DT-STBM7025

FLASH



E SERIES™

(Adjustable Pin-style Ball Mount)

The engineering, design, and craftsmanship of the E series™ is superior to any other pin-style ball mount on the market. Adjustments are quick and easy, making it effortless to switch between trailers and get on the road faster. Its gorgeous mirror finish will make your buddies jealous every time you tow.



E series features:

- Fast and easy adjustments, saving you time and effort
- Polished aluminum, making your truck look its best
- Precision machined for strength and durability
- Aircraft-grade aluminum for corrosion resistance and outstanding performance
- Super strength alloy for years of safe towing
- 1,000 lb. max tongue wt. / 10,000 lb. max trailer wt.
- Limited one year warranty
- Made in the USA

E series options:

- 4, 6, 8, or 10 inch drops (5, 7, 9, or 11 inch rise)
- 2" & 2-5/16" hitch balls

We offer a keyed alike locking hitch pin and height adjustment pin pack, part # 86-00-3660



E series models:

	4" / 5" drop/rise	6" / 7" drop/rise	8" / 9" drop/rise	10" / 11" drop/rise
Chrome Balls 2" & 2-5/16" 2" Shank	42-00-2400	42-00-2600	42-00-2800	42-00-2900



E SERIES HD™**(Heavy Duty Adjustable Pin-style Ball Mount)**

The E series HD™ is gorgeous, surprisingly light, and built to tow your heaviest trailers. Made from a solid piece of aircraft-grade aluminum, the HD won't rust, and commands attention with its hand polished, mirror finish. If you are looking for an HD ball mount to fit your 2½" receiver, look no further; you will not find a better heavy duty ball mount than the E series HD.

**E series HD options:**

- 6, 8, or 10 inch drops (7, 9, or 11 inch rise)
- 2" & 2-5/16" hitch balls

**E series HD features:**

- 1,800 lb. max tongue wt. / 18,000 lb. max trailer wt.
- Fast and easy adjustments, saving you time and effort
- Polished aluminum, making your truck look its best
- Precision machined for strength and durability
- Aircraft-grade aluminum for corrosion resistance and outstanding performance
- Super strength alloy for years of safe towing
- Limited one year warranty
- Made in the USA

We offer a keyed alike locking hitch pin and height adjustment pin pack, part # 86-00-3685

**E series HD models:**

	6" / 7" drop/rise	8" / 9" drop/rise	10" / 11" drop/rise
Chrome Balls 2" & 2-5/16" 2" Shank	42-00-2625	42-00-2825	42-00-2925

FLASH



LBM series

(Fixed Height Locking Ball Mount)

The Fastway Flash LBM is not only gorgeous, but a big step up in both security and convenience compared to other locking ball mounts. With the lock built right into the hitch, you no longer need a separate hitch pin, and you'll know your ball mount is secure. A simple 1/4 turn provides quick locking and unlocking, saving you time and effort, every time you tow.



LBM options:

- 2, 4, or 6 inch drops (1, 3, or 5 inch rise)
- Sizes for 1" or 1-1/4" hitch ball shanks
- Hitch ball sold separately

LBM features:

- Strong stainless steel integrated lock pins
- Aircraft-grade aluminum and stainless steel construction
- 1,000 lb. max tongue wt. / 10,000 lb. max trailer wt.
- Easy access front-facing lock
- Hand polished mirror finish
- Precision machined for strength and durability
- Limited one year warranty
- Made in the USA

LBM models (2" shank):

	2" / 1"	4" / 3"	6" / 5"
1" Hole	DT-LBM8200	DT-LBM8400	DT-LBM8600
1-1/4" Hole	DT-LBM9200	DT-LBM9400	DT-LBM9600



BM series

(Fixed Height Ball Mount)

The Fastway Flash BM is not only strong, but the best looking standard ball mount on the market. If you want a tough ball mount that is built-to-last and makes your truck look fantastic, the Flash BM is the ball mount for you.



BM options:

- 2, 4, or 6 inch drops (1, 3, or 5 inch rise)
- Sizes for 1" or 1-1/4" hitch ball shanks
- Hitch ball sold separately



BM features:

- Aircraft-grade aluminum for corrosion resistance and outstanding performance
- 1,000 lb. max tongue wt. / 10,000 lb. max trailer wt.
- Hand polished mirror finish making your truck look its best
- Limited one year warranty
- Made in the USA

BM models (2" shank):

	2" / 1"	4" / 3"	6" / 5"
1" Hole	DT-BM4200	DT-BM4400	DT-BM4600
1-1/4" Hole	DT-BM5200	DT-BM5400	DT-BM5600

FLASH





flip
automatic
jack foot™

Fastway Flip™

Fastway Trailer Products - Faster, Easier.™

Fastway Flip Automatic Jack Foot

Kiss Those 2x4's Goodbye!

Stop fumbling with a stack of wood blocks to stick under your tongue jack. The Fastway Flip jack foot extends your jack by six inches and is the only jack foot that is completely automatic. The Flip puts itself away, with no springs, cables, pins, or clips required.



The Fastway Flip jack foot adds six inches to your 2" or 2 1/4" jack. It automatically drops into place when you extend your jack, and tucks up and out of the way when you retract it for towing.

With a Flip jack foot there is:

- No bending or kneeling
- Nothing extra to keep track of or store
- 50 cranks saved both up and down
- No tinkering – automatically locks down and flips up

Get a Fastway Flip jack foot today and say goodbye to your tongue jack hassles.

Flip Automatic Jack Foot

Part #	Description
88-00-4500	Flip for 2-1/4" jack x 4" tall
88-00-6500	Flip for 2-1/4" jack x 6" tall
88-00-6525	Flip for 2" jack x 6" tall

Flip Jack Pack

You'll Flip Over This Upgrade

When you need to replace your tongue jack, don't settle for any old jack. Get the Fastway Flip jack pack; a complete package including a Flip automatic jack foot (the only foot that extends and retracts automatically) and a top quality 2 1/4" A-frame jack; pre-drilled to make installing your new Flip jack foot even easier!



The Flip jack foot is rated to lift up to 4,000 lbs. and works easily with most travel, cargo, utility, flatbed, ATV, and horse trailers.

Electric Jack Pack Features:

- 4,000 lb. lift capacity handles heavy loads with ease
- Three year limited warranty
- LED work light makes nighttime hitching easy
- Positive and negative leads eliminate 'ground-through-frame' corrosion issues
- Three built-in levels of motor protection - fuse, clutch, and thermal breaker



Flip Jack Packs

Part #	Description
88-00-5165	Flip Top-wind Jack Pack
88-00-6265	Flip Side-wind Jack Pack
88-00-7065	Flip Electric Jack Pack





CAUTION
SAFETY BREAK-AWAY
SWITCH WILL NOT OPERATE
unless connected to a power source
equivalent to or greater than an auto-
motive type 12 volt, 12 amp hour wet-
cell battery.

ZIPTM
Trailer Breakaway
Cable & Switch

Fastway ZipTM

Fastway Trailer Products - Faster, Easier.TM

Fastway Zip Breakaway Cable

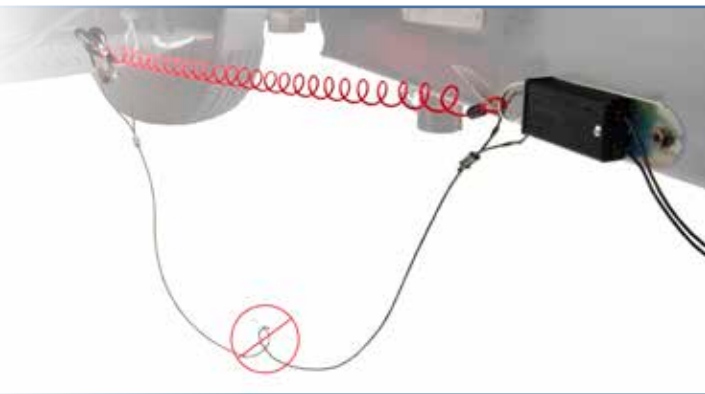

Zip coiled cable stays off the ground so it lasts longer and doesn't stab your fingers.

The best breakaway cable, ever.

Is your old breakaway cable dragging on the ground? Is it frayed or broken? Stop stabbing your fingers on an old rusty cable. Replace it with the Fastway Zip™ breakaway cable; the cable that doesn't drag.

The Zip stays off the ground and out of harm's way while you're towing. When you're not towing, the cable easily clips to itself and stays out of the way, instead of dangling all over the front of your trailer.

There is a Zip breakaway cable for every trailer. We have two different lengths of cables in three different styles. We recommend the 4' cables for bumper pull trailers, and the 6' cables for gooseneck or 5th wheel trailers.



Zip Cable and Switch

If you need to replace your entire breakaway system, you need the Zip model that includes both the switch box and the coiled cable.

Zip Cables w/ Switch

Part #	Description
80-00-2040	4' Cable & Switch
80-00-2060	6' Cable & Switch



Zip Cable and Pin

If you want to upgrade your cable and also need a new pin for your existing switch, the Zip Cable and Pin works great. The pin is compatible with all Zip switches, most Bargman® brand breakaway switches, and other makes with similar pin styles.

Zip Breakaway Cables

Part #	Description
80-01-2204	4' Cable & Pin
80-01-2206	6' Cable & Pin



Zip Universal Replacement

If you want to upgrade your cable, but have a different style pin than the Zip Cable and Pin (above), you'll need the Zip Universal Cable Replacement, designed with a split ring to easily thread onto your existing pin.

Part #	Description
80-01-2140	4' Universal Cable
80-01-2160	6' Universal Cable



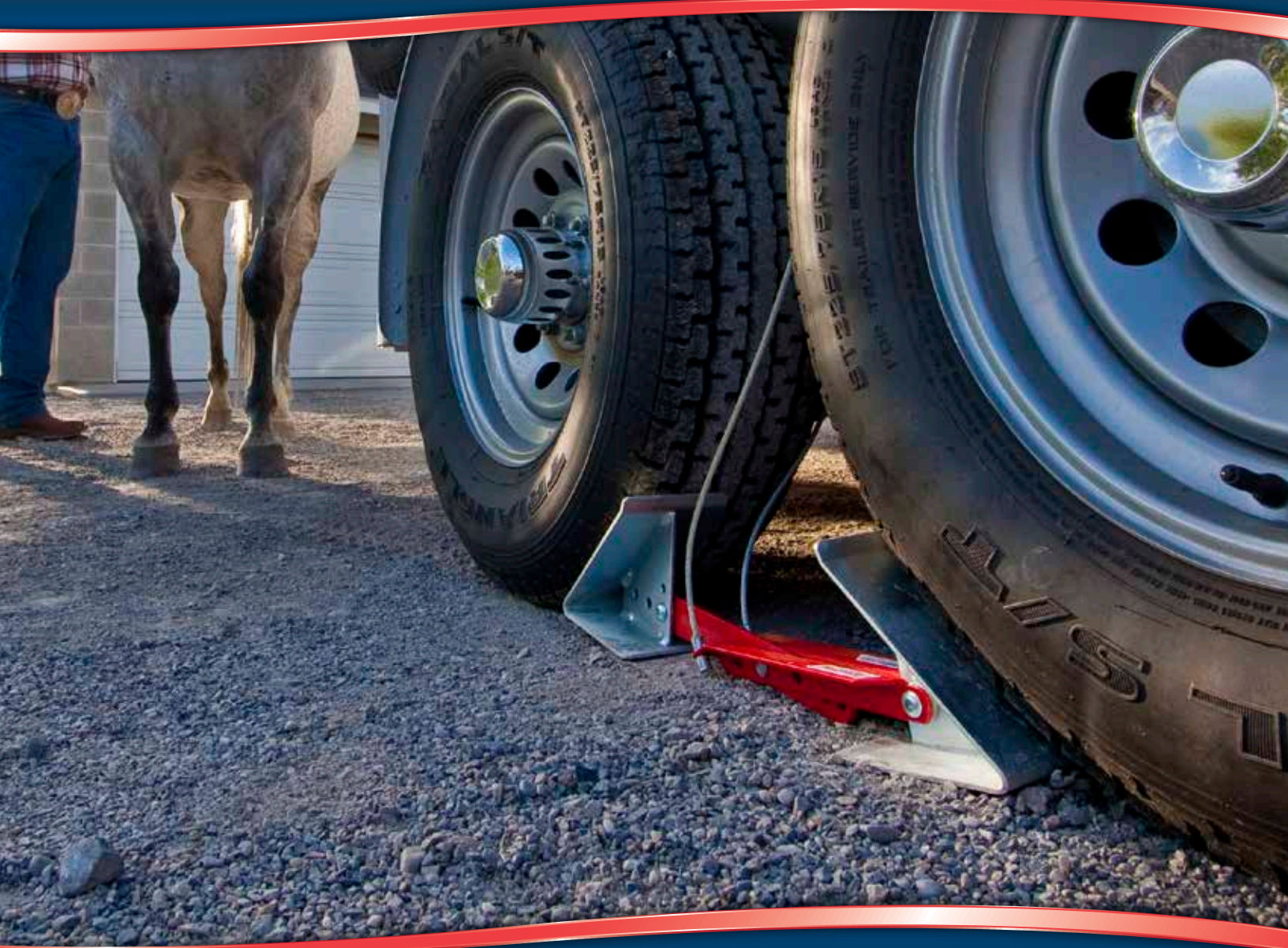

ONEstep™
tandem axle wheel chock

Fastway ONEstep™

Fastway Trailer Products - Faster, Easier.™

Fastway ONEstep Tandem Axle Wheel Chock



With the Fastway ONEstep™ chock, you can throw away the chunk of wood or rock you've been using under your trailer tire. The ONEstep is the fastest and easiest tandem axle wheel chock available. To set the chock, simply slide it into place and step down. No bending or kneeling required. When you're ready to go, pull up on the cable handle, and the ONEstep chock pulls right out.

The ONEstep chock is perfect for travel trailers, 5th wheels, boat, cargo, horse, farm, and utility trailers.

With the ONEstep you get:

- Installation and removal in seconds
- No bending or kneeling
- No tiresome ratcheting
- A trailer that is stable and securely held both forward and backward
- Adjustments from 16" to 24"
- XL model that fits wide-axle trailers from 16" to 30"
- Durable powder coat and zinc plate finish

ONEstep XL™



Use your foot to spread the chocks between the tires.



Step down firmly.



Lean the cable handle on the tire and you're done.

ONEstep Wheel Chocks

Part #	Description
84-00-4000	Fastway ONEstep (16"-24")
84-00-4150	Fastway ONEstep XL (16"-30")
84-00-4840	Fastway ONEstep 2 pk. (16"-24")



Fastway Locks

Fastway Trailer Products - Faster, Easier.™

Fastway Locks

Fastway locks are made from the highest quality corrosion resistant material, providing maximum security and peace of mind. With a limited lifetime warranty, you know your trailer is secure with a Fastway lock.



Fastway Maximum Security Universal Coupler Lock

The Fastway Maximum Security Universal Coupler Lock is the most secure and universal coupler lock available. It's made from the highest quality corrosion resistant material and fits almost any trailer coupler style.

- Two barrel-style keys included
- Anti-drill lock design
- Keyed-alike case quantity (10) available for fleets

Part #	Description
86-00-5015	Maximum Security Universal Coupler Lock

Fastway *E*SERIES™ and *E*SERIES *HD*™ Dual Lock Packs



The E series and E series HD dual lock packs are a faster, easier, and better way to securely lock both the ball holder to the drop bar and the drop bar in the receiver.

Part #	Description
86-00-3660	E series Dual Lock Pack
86-00-3685	E series HD Dual Lock Pack NEW!

Fastway Receiver Lock



Make sure your hitch is safe by purchasing a top-of-the-line locking hitch pin. With drill-resistant barrel locks that cannot be 'false locked' and weather resistant O-rings with rubber dust caps, the Fastway locking hitch pin is a faster, easier, and better way to lock your hitch in your receiver.

Part #	Description
86-00-3050	5/8" Locking Hitch Pin - 2" Receiver
86-00-3160	5/8" Locking Hitch Pin - 2-1/2" Receiver
DT-30010	Coupler Latch Lock



Fastway Towing Accessories

Fastway Trailer Products - Faster, Easier.™

Fastway Towing Accessories

Chain-Up



Every trailer needs a Chain-Up™, the fastest and easiest way to keep your safety chains from dragging. Twisting your chains to shorten them is a hassle and dangerous. The Chain-Up will protect you and your trailer by keeping your safety chains off the ground.

Two different models are available: one for use with a fixed ball mount, and the other for use with an adjustable height or multi-ball mount, or weight distribution style hitch head.

There is no faster or easier way to keep your safety chains from dragging!

Part #	Description
82-00-3065	Chain-Up for Ball Mount
82-00-3090	Chain-Up for Adjustable Height, Multi-ball, or Weight Distribution Hitch

Tethered Ball Cover



Let the Fastway tethered Ball Cover take away some of the hassle and mess of keeping your hitch ball properly lubed. It will keep the grease off your clothes when you're not towing. The convenient tether loops around your hitch ball to keep it from getting lost while you are on the road.

Two different models are available: one for a 2" ball, and one for a 2-5/16" ball.

Part #	Description
82-00-3220	2" Ball Cover w/ Tether
82-00-3216	2-5/16" Ball Cover w/ Tether

Tethered 7-pin Plug Cover



The Fastway tethered 7-pin Plug Cover is a fast and easy way to keep dirt, bugs, and corrosion out of the 7-pin wiring harness plug between trips or while a trailer is in storage.

The convenient tether keeps the cover from getting lost. It's right where you need it when you're done towing and ready to put your trailer away.

Part #	Description
82-00-3315	7-Way Plug Cover

Shin Guard Safety Cover



When you were a kid, Mom made sure you were wearing your shin guards on the soccer field. Now that you're all grown up, we're stepping in. With the Fastway Shin Guard™ safety cover, you'll no longer worry about banging your shin on the edge of your ball mount.

The Shin Guard fits both 2-5/16" and 2" hitch balls on ball mounts up to 2-1/2" wide. It is available in three colors, and comes with a tether to keep your wiring harness from dragging.

Part #	Description
82-00-3125	Shin Guard - Black w/ Tether
82-00-3126	Shin Guard - Orange w/ Tether
82-00-3127	Shin Guard - Yellow w/ Tether

Fastway Marketing Material

At Fastway, we are committed to our dealers. Our goal is to provide superior dealer support, and help you move our products off your shelves.

We have displays, end caps, marketing materials, brochures, shelf-talkers, videos, and more to educate your sales team and your customers. Whether you have a big showroom, or a small spot on your counter, we have marketing materials that will teach your customer how they can tow faster and easier with the Fastway line.

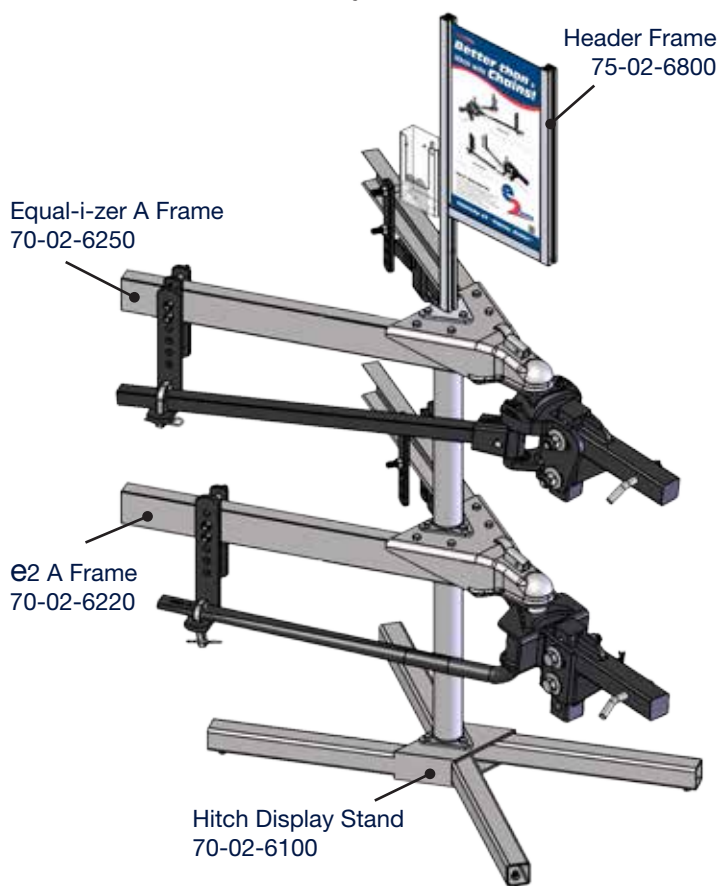

e2 Hitch Display Stand

Our e2 hitch display includes the base, upright stand, trailer A-frame, and signage to help you show your customers how they can tow faster and easier with an e2 hitch.

Choose between single and double hitch displays with either the round-bar or trunnion hitch. Call your manufacturer representative to determine which hitch display is best for you.



Double Sided Stand Alone Display

Two Foot Stand Alone Display

New Fastway Double Sided Stand Alone Display

When people have a 'hands-on' experience they love our gear. The built-in receiver bar allows you to display the coupler lock and several Flash ball mounts. We've added a miniature Flip display and a way to show off the ONEstep wheel chocks. The new display is quick to set up, and lightweight so you can easily move it around your showroom or parts department.

Includes:

- 24" wide x 72" tall slat-grid frame
- Miniature working Flip display
- Hands-on ONEstep display
- Flash receiver bar attachment
- Product shelves, hangers, and assembly instructions.

Product not included.

Fastway End Cap Display (not pictured)

The end cap display allows you to showcase your favorite Fastway gear. The preloaded video monitor acts as an extra sales rep, by teaching customers about some of our top selling products: the Zip breakaway cable, Flip jack foot, ONEstep wheel chocks, and e2 hitch.

Includes:

- 34" wide x 20" tall full color header with pegboard mounting hardware
- 7" video monitor pre-loaded with promotional video specific to your customer base
- Shelf signage and branding

Shelving and product not included.



78-00-4000



78-00-5110

Flip Stand Display and Mini Flip Display

It's time for your customers to stop fumbling with a stack of wood blocks to stick under their tongue jack! Our Flip displays easily demonstrate how the Flip automatically lowers and raises to put itself away. Your customers will love testing it for themselves.



78-00-7550

Coupler Lock Display Stand

Showcase the Fastway Maximum Security Coupler Lock with our new display! The display can be used with our ball mount display stand or the gondola display and will increase your coupler lock sales.



79-00-8000

Flash Ball Mount Display Stand

The new counter-top Flash display provides your customers the opportunity to take a close look at the hand polished aluminum, visualize the ball mount on the back of their truck, and see exactly what they are purchasing.



78-00-6330

Flash Gondola Display

Our new Gondola display easily attaches to the gondola shelving in your parts store and gives customers a hands-on experience, increasing your Flash ball mount sales. Each display holds three Flash ball mounts, so customers can compare the models and decide which one is right for them.



80-01-9214

Zip Breakaway Cable Counter Top Display

Get the Zip counter top display to easily showcase one of our most popular products and teach customers how they can tow safer with our Zip breakaway cable.

BZ340



BZ345

e2 Hitch Weight Distribution and Sway Control Poster

Our Work or Play Poster shows your customers how Fastway products save them time and hassle when heading out on a job or a day of fun. Our e2 Poster helps educate your customers on the safety benefits of weight distribution and sway control.

BZ301

DTBM345

BZ320



Fastway Brochures

We have three brochures to help you sell Fastway products. The Fastway brochure features descriptions and photos of our entire product line. The Flash brochure explains the benefits of our Made in America, polished-aluminum ball mounts, and our e2 brochure helps educate customers on the added safety, speed, and ease of built-in-sway control.

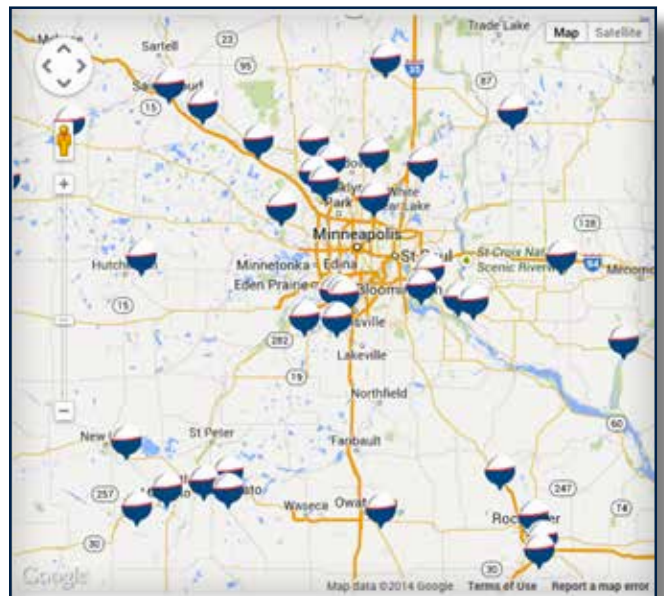

Fastway Dealer Locator

Take advantage of our national marketing campaigns.