

2020

LIVE.
WORK.
PLAY.

BULLDOG®



Horizon Global is the #1 designer, manufacturer and distributor of a wide variety of high-quality, custom engineered towing, trailering, cargo management and other related accessory products in North America, Australia and Europe.

REESE

REESE brand has become a household name in the **heavy-duty towing** industry. From heavy duty fifth wheels and pin boxes to weight distribution systems to control sway, REESE's proven designs exceed industry standards, making it the brand of choice when performance is the expectation.

DRAW-TITE

Draw-Tite was born out of a passion for outstanding performance and has come to represent **one of the best custom-fit vehicle products** available today. Each hitch designed must pass rigorous tests to become Tested Tough™. Draw-Tite is the brand of choice for years of dependable service.

FULTON

Fulton performs best when the weather is at its worst. When innovative design is combined with quality and value, the result is a brand that is the obvious choice for recreational and marine applications everywhere. The Fulton line of trailer jacks, winches, and couplers has become the **industry standard for light and medium-duty trailering**.

BULLDOG

The BULLDOG line is characterized by unmatched strength, reliability, safety and value; count on BULLDOG to be Tough and Tested™. Gooseneck hitches, gooseneck couplers, jacks, trailer couplers and Wedge-Latch™ elements feature a high-strength, heavy-duty design that makes them the **toughest trailer components** available today.

TEKONSHA

Tekonsha has evolved to become a **trusted name in towing safety**. The core product line consists of brake controllers, electrical wiring, trailer brakes, ModuLite® Modules and T-One® T-Connectors. Smooth, predictable stopping at all speeds has made the Tekonsha Prodigy®, Primus® and Voyager® trailer brake controls the best in class and most popular on the market.

**LIVE.
WORK.
PLAY.**

PACKAGING LEGEND | NEW

Our all NEW 2020 product catalog contains packaging type and master carton quantity for every product. This NEW information can be found in the product table on each page. The below legend provides examples and definitions of each packaging type.



BOXED

Single wall corrugated cardboard box with product UPC



LITHO BOX

Litho laminated single wall corrugated cardboard display box



PLASTIC SHROUD

Polyethylene display covers that are sealed and trimmed



CLAMSHELL

One-piece plastic display container with hinge and insert card



DISPLAY CARD

Open product tied or wired to corrugated display card



PDQ TRAY

Point-of-sale cardboard display tray



DISPLAY BAG

Clear polyethylene bag with branded display



BLISTER CARD

Clear thermoformed plastic with display card



DISPLAY LABEL

Branded display labels on open product



POLY BAG

Clear polyethylene bag with label



REEL

Polyethylene reel without display card



JAR

Plastic jar with screw on lid and branded display



SLEEVE

Display card wrapped around open product



BULK

Multiples shipped without display packaging



Master Carton
Quantity of 4

MASTER CARTON

Outer box that contains the packaged products. Keeps products protected during shipping and storage.

TABLE OF CONTENTS | 2020

RECEIVER HITCHES.....A

Class I and II Receivers.....	A-4
Class III and IV Receivers.....	A-5
Class V Receivers.....	A-5 - A-7
Front Mounted Receivers.....	A-11 - A-13
Application Guide.....	A-15 - A-142

HITCH ACCESSORIESB

Hitch Balls.....	B-3 - B-5
Ball Mounts.....	B-6 - B-14
Pintle Hooks.....	B-17 - B-20
Accessories.....	B-20 - B-24

ELECTRICAL WIRING.....C

T-One® Connectors.....	C-5
ModuLite® Power Modules.....	C-8 - C-10
Tail Light Converters.....	C-11
Wire Harnesses.....	C-12 - C-25
Accessories.....	C-26 - C-33

BRAKE CONTROLS.....D

Proportional Brake Controls.....	D-2 - D-4
Timed Brake Controls.....	D-5 - D-6
Wiring Harness Application Guide.....	D-10 - D-12

WEIGHT DISTRIBUTIONE

Weight Distributing Systems.....	E-2 - E-4
Sway Controls.....	E-6 - E-8
Weight Distribution Accessories.....	E-7 - E-8

FIFTH WHEEL HITCHES.....F

M5 Series.....	F-2
Standard Series.....	F-3 - F-4
Mounting Rails and Brackets.....	F-5
Fifth Wheel Accessories.....	F-7 - F-8
Application Guides.....	F-9 - F-12

GOOSENECK HITCHES.....G

Gooseneck Coupler For Rvs.....	G-2
Elite™ Series Gooseneck System.....	G-3 - G-4
Draw-Tite® Gooseneck Systems.....	G-5 - G-7
Above-Bed Gooseneck.....	G-8

PIN BOXES.....H

Gooseneck Coupler For Rvs.....	H-3
Pin Boxes.....	H-2 - H-5
Custom Wedges.....	H-6

CARGO MANAGEMENTI

Roof Racks.....	I-3
Cargo Carriers.....	I-3 - I-5
Cargo Bags.....	I-6
Bike Carriers.....	I-7 - I-8
Watercraft Carriers.....	I-9
Truck and Van Racks.....	I-9 - I-10
Cargo Securing.....	I-11 - I-15

TRAILER JACKS.....J

Powered Jacks.....	J-3 - J-6
Marine and Recreational Jacks.....	J-6 - J-10
Round Jacks.....	J-11 - J-14
Square Jacks.....	J-15 - J-24
Specialty Jacks.....	J-25 - J-29

TRAILER COUPLERSK

Gooseneck Couplers.....	K-2 - K-7
Heavy Duty Couplers.....	K-8 - K-10
Standard Couplers.....	K-10 - K-12

WINCHES.....L

Trailer Winches.....	L-2 - L-8
Electric Winches.....	L-9 - L-12
Hoists.....	L-11 - L-12

TRAILER LIGHTINGM

Tail Lights.....	M-3 - M-22
Clearance / Side Marker Lights.....	M-23 - M-35
Light Bars.....	M-38 - M-39
Auxiliary Lights.....	M-39 - M-44
Agricultural Lights.....	M-46 - M-50

TRAILER/VEHICLE ACCESSORIESN

Breakaway Systems.....	N-2 - N-5
Trailer Brake Parts.....	N-6 - N-10
Wheel Protection.....	N-9 - N-11
Trailer Accessories.....	N-12 - N-16
Vehicle Accessories.....	N-14 - N-16

MERCHANDISINGO

Product Displays.....	O-2 - O-5
Marketing Material.....	O-6 - O-8

TECHNICAL.....P

Electrical Wiring.....	P-2 - P-4
Brake Controls.....	P-5 - P-10
Trailer Brakes.....	P-10 - P-113
Electrical Testers.....	P-14 - P-15
Trailer Lighting.....	P-16 - P-22
Trailer Jacks.....	P-23 - P-27
Winches and Hoists.....	P-28 - P-34

INDEX.....Q

Receiver Hitches.....	Q-4 - Q-21
Front Mount Receiver Hitches.....	Q-21 - Q-22
Brake Control Harnesses.....	Q-22 - Q-26
T-One® Connectors.....	Q-26 - Q-33
Fifth Wheel Harnesses.....	Q-37 - Q-38
Fifth Wheel Rail Kits.....	Q-38 - Q-41
Gooseneck Hitches.....	Q-42 - Q-43
Product Index.....	Q-44 - Q-64

NEW PRODUCTS | 2020



REESE® **SIDEWINDER™**

Nimble and quick, worry-free turning REESE® Sidewinder™, is the premium pin box designed specifically for short bed pickups. It is designed to automatically eliminate turning and clearance headaches. Now you can make up to 90-degree plus turns without exiting the truck. Without throwing a switch. Without pushing a button.

i See page H-2 for complete information



POWERED FIFTH WHEEL RV LANDING GEAR SYSTEM

REESE® RV Jack quickly and easily raises, levels and supports your fifth-wheel trailer or RV with this powerful pair of jacks. Powerful high-speed electric motors operate independently for precise leveling and are capable of 9 in. of lift per minute.

i See page J-5 for complete information



REESE® PRO ROUND BAR SYSTEM

This weight distributing system is engineered to provide more features and superior ride performance to other systems. Designed to evenly distribute weight and reduce trailer sway.

i See page E-2 for complete information



DRAW-TITE®

DRAW-TITE® EURO HITCH

Introducing the latest innovation from the industry leader in towing! Unlike the typical towing receiver, The Draw-Tite® Euro Hitch provides the ability to quickly and easily remove the receiver box when not in use, returning the vehicle to it's original "fresh from factory" look. But when you're ready to tow or attach an accessory such as a bike rack, you can easily reinsert the receiver in less than 5 seconds!

i See page A-2 for complete information



FULTON

FULTON® MARINE BALL MOUNTS

- Solid one-piece forged aluminum construction resists rust and corrosion
- 1 in. thick x 3 in. wide ball platforms
- Fits 2 in. square receiver tube opening
- Designed for marine use
- 8,000 lbs. capacity

i See page B-9 for complete information



RECEIVER HITCHES

The most trusted name in trailer hitches, Draw-Tite® has been at the forefront of trailer hitch design and engineering since their first products were delivered in 1946. Every one of Draw-Tite's wide range of designs benefit from a long legacy of research and manufacturing that is unmatched in the industry.

Draw-Tite's innovative low profile designs compliment the rear contours and aerodynamic styling of today's vehicles. Custom designed hitches are specific to vehicle type and model year for simple installation and superior fit with a minimum of bumper cutting or drilling. Removable drawbars and ball mounts enhance the appearance of the vehicle when not in use. All Draw-Tite's hitches meet or exceed V5 CSA and SAE J684 standards and are backed by Draw-Tite's nationwide, limited lifetime warranty.

RECEIVER HITCHES

Hitch Selection Chart.....	A-3
Drawbar Program.....	A-4
Class I and II.....	A-4
Class III and IV.....	A-5
Class V Ultra Frame™.....	A-5 - A-6
Class V Heavy Duty.....	A-6
Class V 3000 Heavy Duty.....	A-7
Class V 4000 Heavy Duty.....	A-7
Motorhome.....	A-8
Step Bumper.....	A-8
Front Mounted.....	A-11

RECEIVER HITCH ACCESSORIES

Combo Bars.....	A-19
Installation Tools.....	A-9 - A-10
Hitch Ball Wrench.....	A-10

FRONT MOUNTED HITCH ACCESSORIES

License Plate Holder.....	A-10
Spare Tire Carrier.....	A-10
Work Step.....	A-10
Skid Plate.....	A-10
Winch Mounting Plate.....	A-10

APPLICATION GUIDES

Front Mounted Receiver Hitches.....	A-11 - A-13
All-In-One Hitch and Electrical.....	A-15 - A-142

DISCONTINUED PRODUCTS..... A-143

NEW

DRAW-TITE® EURO HITCH - A HITCH ONLY WHEN YOU NEED IT!

Introducing the latest innovation from the industry leader in towing! Unlike the typical towing receiver, The Draw-Tite® Euro Hitch provides the ability to quickly and easily remove the receiver box when not in use, returning the vehicle to it's original "fresh from factory" look. When you're ready to tow or attach an accessory such as a bike rack, you can easily reinsert the receiver in less than 5 seconds!

- **2 in.** square receiver tube opening, rated up to 3,500 lbs. gross total weight
- Detachable, easy to insert/remove receiver box
- Anti-theft lockable receiver
- European engineered for years of trouble free use
- Anti-rattle hitch pin for premium performance
- Solid steel construction for maximum strength and safety
- Custom design to each vehicle specific make and model
- Black powder coat finish over E-coat
- Limited lifetime warranty



2020 BMW X5 with Euro Hitch Installed



Detachable, easy to insert and remove



Removable receiver box



Includes receiver box carrying case

Make/Model	Year	Receiver Type	Receiver Size	Part Number	No Drill	Weight Carrying (lbs.)
ACURA						
RDX	18 - 19	Square 3	2	76902	Ø	300/3,500
AUDI						
Q5	18 - 19	Square 3	2	76911	Ø	300/3,500
BMW						
X3	18 - 20	Square 3	2	76906	Ø	300/3,500
X5	17 - 18	Square 3	2	76903	Ø	300/3,500
X5	19 - 20	Square 3	2	76908	Ø	300/3,500
FORD						
Explorer	20 - 20	Square 3	2	76910	Ø	300/3,500
INFINITI						
QX60	14 - 19	Square 3	2	76904	Ø	300/3,500
LEXUS						
RX350	16 - 19	Square 3	2	76905	Ø	300/3,500
SUBARU						
Outback	10 - 19	Square 3	2	76907	Ø	300/3,500
TOYOTA						
Rav4	19 - 20	Square 3	2	76912	Ø	300/3,500

NOTE: Not designed for weight distribution.

CUSTOM BUILT RECEIVER HITCHES



- Top quality in every hitch and receiver we make
- Solid all-welded construction for maximum strength and safety
- Custom built according to manufacturer vehicle weight specifications and model year to ensure perfect fit and top towing performance
- All Draw-Tite® hitches meet and exceed V-5 and SAE J684 standards and are inspected for quality and workmanship
- Computer-aided design and fatigue stress testing ensure a strong design that will withstand road abuse within specified capacities
- Finish is black powder coat over E-coat (industry leading corrosion resistance)
- Backed by a nationwide Lifetime Limited Warranty

SELECTING THE RIGHT HITCH

- Determine the Gross Trailer Weight and Gross Tongue Weight of the trailer that you would like to tow. Check with the trailer manufacturer or if you are not sure, have it towed to a government inspection scale. Remember that the GTW should reflect a fully loaded trailer
- Consult your vehicle’s owner’s manual to determine if your vehicle is rated to safely tow your trailer
- Use the chart below to figure out the minimum Class of hitch that is required
- Consult a Draw-Tite® dealer to find out which hitches are available for your vehicle.

GROSS TRAILER WEIGHT (GTW)																				
LBS.	1K	2K	3K	4K	5K	6K	7K	8K	9K	10K	11K	12K	13K	14K	15K	16K	17K	18K	19K	20K
CLASS I																				
CLASS II																				
MOTORHOME RECEIVER																				
FRONT MOUNTED RECEIVER																				
CLASS III									w/weight distributing											
CLASS IV										w/weight distributing										
CLASS V (2 in.)															w/wd					
CLASS V (2-1/2 in.)																				
CLASS V (3 in.)																				

QUICK DEFINITIONS

- GTW = Gross Trailer Weight ... Weight of the trailer fully loaded
- TW = Tongue Weight ... Weight exerted by the trailer coupler on the hitch ball
- WC = Weight Carrying ... Tow rating capacity of a hitch without a weight distributing system
- WD = Weight Distributing ... Tow rating capacity of a hitch when using a weight distributing system

24 Series
1-1/4 in. Square Receiver Tube Opening



CLASS I SPORTFRAME™ HITCH

- 1-1/4 in. square receiver tube opening
- Economical Class I receiver style hitch
- Removable drawbar, pin and clip sold separately
- Attaches to vehicle frame and/or bumper
- Black powder coat finish over E-coat



Part Number	Description	Gross Trailer Weight (lbs.)	Tongue Weight (lbs.)	Packaging	Master Carton
24 Series	Weight Carrying	Up to 2,000	Up to 200	Boxed	1

36 Series
1-1/4 in. Square Receiver Tube Opening



CLASS II FRAME HITCH™

- 1-1/4 in. square receiver tube opening
- Receiver style hitch and receiver tube opening
- Removable drawbar, pin and clip sold separately
- Neat appearance and all frame attachments
- Black powder coat finish over E-coat



Part Number	Description	Gross Trailer Weight (lbs.)	Tongue Weight (lbs.)	Packaging	Master Carton
36 Series	Weight Carrying	Up to 3,500	Up to 350	Boxed	1

285 Series
1-1/4 in. Square Receiver Tube Opening



CLASS I/II INVISI-HITCH™

- 1-1/4 in. square receiver tube opening
- One piece construction for a stronger hitch and easier installation
- Attachment allows hitch to be affixed well under vehicle for minimum visibility when drawbar is removed
- Includes mounting hardware
- Removable drawbar, pin and clip sold separately
- Black powder coat finish over E-coat



Part Number	Description	Gross Trailer Weight (lbs.)	Tongue Weight (lbs.)	Packaging	Master Carton
285 Series	Weight Carrying	Up to 3,500	Up to 350	Boxed	1

DRAWBAR PROGRAM FROM DRAW-TITE®

- Draw-Tite® is proud to present the **Drawbar Program**. Over the years, customers have requested the option of purchasing the Class I and Class II hitch and drawbar separately. Now you can. Like the Receiver Plus Program, the **Drawbar Program offers specially priced drawbars with each Class I or Class II hitch sold**. Please NOTE: Discounted pricing is only available on one drawbar kit per hitch, and only when the two are purchased together.

• How to take part:

1. Choose the correct Class I or Class II hitch part number for the vehicle application.
2. Determine if you need a drawbar (Yes/No)

IF YES, order as follows:

Hitch (24824) + Drawbar (3594) = 248240 part number. Adding a zero to the end of the number will show that the two parts are being ordered together. If no drawbar is need, order the standard part number (24824).



75 Series
2 in. Square Receiver Tube Opening



CLASS III/IV SQUARE & ROUND TUBE MAX-FRAME™ HITCHES

- 2 in. square receiver tube opening
- Max-Frame receivers are designed for customers with trucks, vans and sport utility vehicles
- All frame attachments
- Black powder coat finish over E-coat
- J-Pin™ ready
- 75xxx ball mounts #23 and #53 are available (Max-Frame Program)



Part Number	Description	Gross Trailer Weight (lbs.)	Tongue Weight (lbs.)	Packaging	Master Carton
75 Series	Weight Carrying	Up to 8,000	Up to 1,200	Boxed	1
75 Series	Weight Carrying	Up to 12,000	Up to 1,200	Boxed	1

41 Series
2 in. Square Receiver Tube Opening



CLASS III/IV MAX-E-LOADER™ HITCH

- 2 in. square receiver tube opening
- Max-E-Loader's long side bracket distributes the towing load over a greater portion of the vehicle frame
- All frame attachments
- J-Pin™ ready
- Black powder coat finish over E-coat



Part Number	Description	Gross Trailer Weight (lbs.)	Tongue Weight (lbs.)	Packaging	Master Carton
41 Series	Weight Carrying	Up to 6,000	Up to 600	Boxed	1
41 Series	Weight Carrying	Up to 12,000	Up to 1,200	Boxed	1

419 Series
2 in. Square Receiver Tube Opening



CLASS V ULTRA FRAME™ HITCH

- 2 in. square receiver tube opening
- Designed for full-size trucks, vans and utility vehicles with full frames and heavy-duty suspensions
- Ideal for high tongue weight applications (Example: Toy Hauler)
- Strong, secure heavy-duty side bracket design
- All frame attachments
- J-Pin™ ready
- Black powder coat finish over E-coat
- Redesign of Ultra Frame™ receivers to include Cast Center Section
 - Rugged appearance
 - Tighter ball mount fit
 - Cast steel material
 - Reinforced pin hole
 - Bigger chain loops



NOTE: Contact Customer Service for availability of new Cast Center Section part numbers

Part Number	Description	Gross Trailer Weight (lbs.)	Tongue Weight (lbs.)	Packaging	Master Carton
419 Series	Weight Carrying	Up to 15,000	Up to 1,500	Boxed	1
419 Series	Weight Distributing	Up to 16,000	Up to 1,600	Boxed	1
419 Series	Weight Carrying with Cast Center	Up to 16,000	Up to 2,400	Boxed	1
419 Series	Weight Distributing with Cast Center	Up to 16,000	Up to 1,600	Boxed	1

CLASS V ULTRA FRAME™ WORK TRUCK HITCH



41990

- 2 in. square receiver tube opening
- Manufactured for service body and flat bed stake trucks
- Mix and match center section and side brackets
- Versatile for various makes and models
- Fabrication kit requires welding
- 41991 satisfies DOT SEC. 393 .86 (b) (1)t



41990-07



41990-16

Part Number	Description	Gross Trailer Weight (lbs.)	Tongue Weight (lbs.)	Packaging	Master Carton
4916	Ultra Frame, Long 16 Side Bracket	—	—	Boxed	1
4907	Ultra Frame, Short 7 Side Bracket Kit Only	—	—	Boxed	1
41990	Ultra Frame, 44 Crosstube Only	16,000	1,600	Boxed	1
41990-07	Ultra Frame, includes: 41990 (44) and 4907	16,000	1,600	Boxed	1
41990-16	Ultra Frame, includes: 41990 (44) and 4916	16,000	1,600	Boxed	1
41991	Ultra Frame, 62 Crosstube Only	16,000	1,600	Boxed	1
41991-07	Ultra Frame, includes: 41991 (62) and 4907	16,000	1,600	Boxed	1
41991-16	Ultra Frame, Includes: 41991 (62) and 4916	16,000	1,600	Boxed	1

455 Series
2-1/2 in. Square Receiver Tube Opening



CLASS V HEAVY DUTY HITCH

- 2-1/2 in. square receiver tube opening
- Designed for full-size long wheelbase trucks, vans and utility vehicles with full frames and heavy-duty suspensions
- Ideal for high tongue weight applications (Toy Hauler and Commercial)
- Strong, secure heavy-duty side bracket design
- Pin, clip and receiver tube cover included
- Black powder coat finish over E-coat
- Welded electrical bracket included



Part Number	Description	Gross Trailer Weight (lbs.)	Tongue Weight (lbs.)	Packaging	Master Carton
455 Series	Weight Carrying	Up to 18,000	Up to 2,000	Boxed	1
455 Series	Weight Distributing	Up to 18,000	Up to 2,500	Boxed	1

38023 - Class V Heavy Duty 3000
3 in. Square Receiver Tube Opening



38211 - Class V Heavy Duty 3000
3 in. Square Receiver Tube Opening

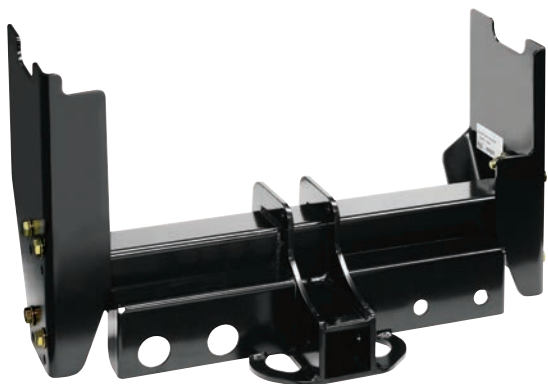

38208 - Class V Heavy Duty 4000
3 in. Square Receiver Tube Opening



CLASS V HEAVY DUTY 3000 HITCHES

- **3 in.** square receiver opening
- 20,000 lbs. weight carrying capacity;
3,000 lbs. tongue weight
- Adjustable cross tube for proper height
- Two electrical plug and air brake hook up mounting locations for easy trailer attachments
- Air brake hook up locations
- Dual ball mount with 2 in. and 2-5/16 in. balls included
- Pin and clip included
- For frame widths from 33-1/2 in. to 34-1/2 in.
- Welds to frame of vehicle



Part Number	Description	Gross Trailer Weight (lbs.)	Tongue Weight (lbs.)	Packaging	Master Carton
38023	Weight Carrying, Dual Ball Mount	Up to 20,000	Up to 3,000	Boxed	1
38211	Weight Carrying, Dual Ball Mount	Up to 20,000	Up to 3,000	Boxed	1

NOTE: 38023 is 10 from bottom of frame to bottom of receiver tube
NOTE: 38211 is 14-1/2 from bottom of frame to bottom of receiver tube

CLASS V HEAVY DUTY 4000 HITCHES

- **3 in.** square receiver opening
- 25,000 lbs. weight carry capacity;
4,000 lbs. tongue weight
- Dual stacked receivers for proper height adjustment
- Two electrical plug and air brake hook up mounting locations for easy trailer attachments
- For frame widths from 34 in. to 34-1/2 in.
- Air brake fittings for easy trailer hookups
- Dual ball mount with 2 in. and 2-5/16 in. balls included
- Pin and clip included



Part Number	Description	Gross Trailer Weight (lbs.)	Tongue Weight (lbs.)	Packaging	Master Carton
38124	Weight Carrying, Dual Ball Mount	Up to 25,000	Up to 4,000	Boxed	1
38208	Weight Carrying, Dual Ball Mount	Up to 25,000	Up to 4,000	Boxed	1

NOTE: 38124 is 14-1/2 from bottom of frame to bottom of dual stacked receiver tube
NOTE: 38208 is 10-1/2 from bottom of frame to bottom of dual stacked receiver tube

5350 - Multi-Fit Motorhome
2 in. Square Receiver Tube Opening



MULTI-FIT MOTORHOME HITCH

- **2 in.** receiver tube accepts all standard utility ball mounts, providing ball height adjustment for level towing
- Simple three-piece construction makes assembly and installation fast and easy
- Fits frames 24 in. to 36 in. wide
- Attachment hardware included
- Black powder coat finish over E-coat



Part Number	Description	Gross Trailer Weight (lbs.)	Tongue Weight (lbs.)	Packaging	Master Carton
5350	Motorhome Hitch, Adjusts 24 - 36 Wide	5,000 - 6,000	500 - 750	Boxed	1

82201 - Universal Motorhome
2 in. Square Receiver Tube Opening



UNIVERSAL MOTORHOME HITCH

- **2 in.** receiver tube accepts all standard utility ball mounts, providing ball height adjustment for level towing
- Frame brackets are adjustable
- Fits frames 47 in. to 71 in. wide
- Attachment hardware included
- Black powder coat finish over E-coat



Part Number	Description	Gross Trailer Weight (lbs.)	Tongue Weight (lbs.)	Packaging	Master Carton
82201	Motorhome Hitch, Adjusts 47 - 71 Wide	3,500	300	Boxed	1

81378 - Step Bumper
2 in. Square Receiver Tube Opening



STEP BUMPER HITCH

- **2 in.** receiver tube accepts all standard utility ball mounts, providing ball height adjustment for level towing
- Do not exceed maximum GTW of bumper or hitch
- Not to be used with weight distributing systems
- May require modification or additional spacers for installation on late model pick-up
- Hardware included



Part Number	Description	Gross Trailer Weight (lbs.)	Tongue Weight (lbs.)	Packaging	Master Carton
81378	Step Bumper Hitch	3,500	350	Boxed	1

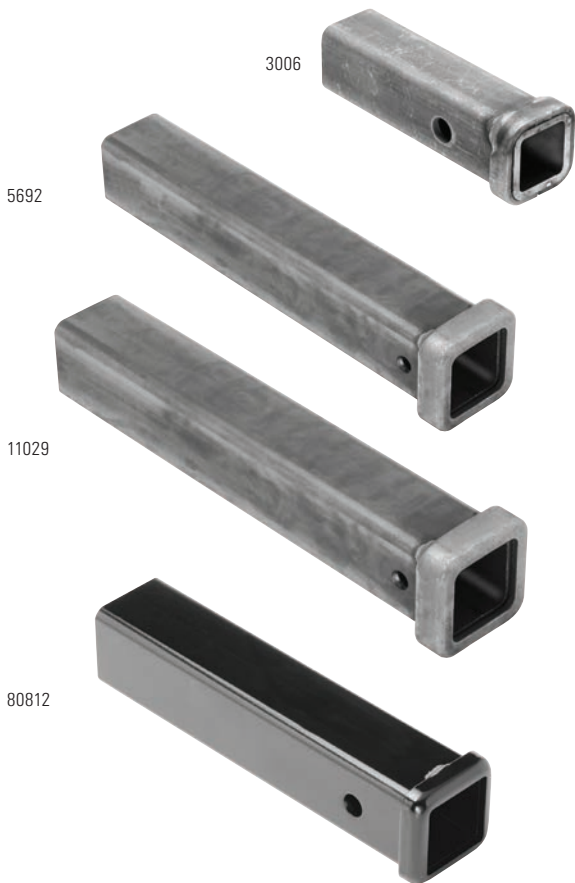

COMBO BARS

- Designed for use in fabricating undercar receiver hitches
- Made of cold formed structural tubing
- Sized and punched to fit all common weight distributing hitch ball mounts or utility ball mounts

Part Number	Description	Length (in.)	Diameter (in.)	Ring	Packaging	Master Carton
Unpainted						
2850	Combo Bar	6	2 x 2	Standard	Boxed	1
11081	Combo Bar	8	2 x 2	Standard	Boxed	1
2851	Combo Bar	12	2 x 2	Standard	Boxed	1
2898	Combo Bar	18	2 x 2	Standard	Boxed	1
2852	Combo Bar	24	2 x 2	Standard	Boxed	1
2853	Combo Bar	36	2 x 2	Standard	Boxed	1
2854	Combo Bar	48	2 x 2	Standard	Boxed	1
3006	Combo Bar	6	1-1/4 x 1-1/4	Standard	Boxed	1
5691	Combo Bar	12	2 x 2	Cast	Boxed	1
5692	Combo Bar	18	2 x 2	Cast	Boxed	1
11029	Combo Bar	18	2-1/2 x 2-1/2	Cast	Boxed	1
Painted						
80806	Combo Bar	6	2 x 2	Standard	Boxed	1
80812	Combo Bar	12	2 x 2	Standard	Boxed	1



DRILL BITS AND HOLE SAWS

- Drill bits and hole saws are especially selected to best suit trailer hitch installations where drilling is required
- With 135° split points for easy starts on flat surfaces
- Made of high carbon, M-2 steel for maximum durability and minimum brittleness

Part Number	Description	Overall Length (in.)	Flut Length (in.)	Packaging	Master Carton
01932-003	3/8 Drill Bits, (3 Pack)	5	3-5/8	Poly Bag	1
01933-003	7/16 Drill Bits, (3 Pack)	5-1/2	4-1/16	Poly Bag	1
01934-003	1/2 Drill Bits, (3 Pack)	6	4-1/2	Poly Bag	1
1935	3/8, 7/16 and 1/2 Drill Bits	-	-	Poly Bag	1
1937	Hole Saw Arbor with Pilot Drill (1936)	-	-	Poly Bag	1
58381	3-1/2 Hole Saw	-	-	Poly Bag	1
1124	Hole Saw Arbor with Pilot Drill (58381)	-	-	Poly Bag	1
01938-003	1/4 Pilot Drill Bit, (3 Pack)	-	-	Poly Bag	1
4655	9/16 Drill Bit with 1/2 Shank	6-1/8	3	Poly Bag	1
40109	3/8 Rotabroach Hole Cutting Tool with Pilot	-	-	Tube	1
40110	7/16 Rotabroach Hole Cutting Tool with Pilot	-	-	Tube	1
6810	1/2 Rotabroach Hole Cutting Tool with Pilot	-	-	Tube	1
6811	9/16 Rotabroach Hole Cutting Tool with Pilot	-	-	Tube	1



5481 / 5482 / 55392 / 55393

INSTALLATION TOOLS

Part Number	Description	Packaging	Master Carton
5481	7/16 Wire Forms, (20 Pack)	Poly Bag	1
5482	1/2 Wire Forms, (20 Pack)	Poly Bag	1
55392	1/2 Wire Forms for Fishwiring Bolts in Frames	Poly Bag	1
55393	3/8 Wire Forms	Poly Bag	1
74342	Hitch Ball Wrench, Boxed End 1-1/8 and 1-1/2	Bulk	5
49803	Fastener Assortment (Carriage Bolts, Blocks, etc.)	Poly Bag	1
58530	Replacement Part, Rubber Bolt Cap for 75662, 87530 and 44603	Poly Bag	1

LICENSE PLATE HOLDERS

- Some states and provinces require a front license plate
- Offers a simple solution where the front hitch interferes with the plate

Part Number	Description	Packaging	Master Carton
5443	License Plate Adapter	Boxed	1
49802	Fold Down License Plate Holder	Boxed	1



SPARE TIRE CARRIER

- Ideal for relocating spare tires to the front of the vehicle using a front mounted receiver
- Universal bolt pattern for mounting a variety of tire sizes

Part Number	Description	Packaging	Master Carton
6715	Spare Tire Carrier, Universal Bolt Pattern	Boxed	1

WORK STEP

- Useful for gaining access to engine compartment, particularly with 4 x 4 pick-ups
- Can also be used on rear Class III/IV hitches

Part Number	Description	Packaging	Master Carton
6758	Work Step	Boxed	1

RECEIVER TUBE SKID PLATE

- Recommended for use with hitches that are mounted below the bumper

Part Number	Description	Packaging	Master Carton
6771	Receiver Tube Skid Plate	Boxed	1

WINCH MOUNTING PLATE

- Rated for 9,000 lbs. line pull
- Ideal for use with BULLDOG™ winches
- Accepts most models of Superwinch, Ramsey and Warn
- Will not fit with S4500 Superwinch

Part Number	Description	Packaging	Master Carton
6495	Winch Mounting Plate	Boxed	1

FRONT MOUNTED RECEIVER HITCHES

65 Series
2 in. Square Receiver Tube Opening



FRONT MOUNTED HITCHES

- 2 in. square receiver tube opening
- Front mounted receivers offer a secure and useful attachment point
- All frame attachments
- J-Pin™ ready
- Ideal for use with winches and snow plows
- Black powder coat finish over E-coat



Part Number	Description	Gross Trailer Weight (lbs.)	Tongue Weight (lbs.)	Packaging	Master Carton
65 Series	Weight Carrying	Up to 9,000	Up to 500	Boxed	1

FRONT MOUNTED RECEIVER HITCH APPLICATION GUIDE

Make/Model	Years	PC	Part No.	Footnotes	Vert Load	Line Pull	In
CHEVROLET							
Avalanche Except Z71	07-13	30	65052	Ø,GP,X	500	9,000	25
Blazer Full Size	92-94	21	65005	JU,JV	500	9,000	40
Blazer Downsize	95-05	24	65004	JW,JX,X	300	9,000	30
Blazer Trailblazer	99-01	24	65004	JW,JX,X	300	9,000	30
C1500 2 Dr. Regular & Extended Cabs	88-99	21	65005	JU,JV,KC	500	9,000	40
		46	65021†	JV,KD,KE	500	9,000	30
C1500 4 Dr. Crew Cab	92-99	46	65021†	JV,KD,KE	500	9,000	30
C2500 2 Dr. Regular & Extended Cabs	88-99	21	65005	JU,JV,KC	500	9,000	40
		46	65021†	JV,KD,KE	500	9,000	30
C2500 4 Dr. Crew Cab	92-00	46	65021†	JV,KD,KE	500	9,000	30
C3500 2 Dr. Regular & Extended Cabs	88-00	21	65005	JU,JV,KC	500	9,000	40
		46	65021†	JV,KD,KE	500	9,000	30
C3500 4 Dr. Crew Cab	92-00	46	65021†	JV,KD,KE	500	9,000	30
Colorado	15-16	23	65071	Ø,X	500	9,000	30
Express 1500 Inc. RV Cutaway	96-03	24	65016	X	500	9,000	35
Express 2500 Inc. RV Cutaway	96-03	24	65016	X	500	9,000	35
Express 3500 Inc. RV Cutaway	96-03	24	65016	X	500	9,000	35
K1500 2 Dr. Regular & Extended Cabs	88-99	21	65005	JU,JV,KC	500	9,000	40
K2500 2 Dr. Regular & Extended Cabs	88-99	21	65005	JU,JV,KC	500	9,000	40
K2500 4 Dr. Crew Cab	92-00	21	65005	JU,JV,KC	500	9,000	40
K3500 2 Dr. Regular & Extended Cabs	88-00	21	65005	JU,JV,KC	500	9,000	40
K3500 4 Dr. Crew Cab	92-00	21	65005	JU,JV,KC	500	9,000	40
S10	94-04	24	65004	JW,JX,X	300	9,000	30
Silverado 1500	99-07	47	65023		500	9,000	20
Silverado 1500	07-13	30	65052	Ø,GP,X	500	9,000	25
Silverado 1500 LD (Old Body Style)	14-19	30	65064	Ø,GP,X,FE	500	9,000	25
Silverado 1500	19	30	65082	Ø,GP,X	500	9,000	25
Silverado 1500 HD	01-03	24	65028	HB	500	9,000	20
Silverado 1500 HD	05-07	24	65028	HB	500	9,000	20
Silverado 2500	99-04	24	65028	HB	500	9,000	20
Silverado 2500 HD	01-07	24	65028	HB	500	9,000	20
Silverado 2500 HD	07-10	22	65050	Ø,EP,GP,RZ	500	9,000	40
Silverado 2500 HD	11-14	24	65078	Ø,GP,EP	500	9,000	45
Silverado 2500 HD	15-19	24	65078	Ø,GP,EP	500	9,000	35
Silverado 3500	01-07	24	65028	HB	500	9,000	20
Silverado 3500 HD	07-10	22	65050	Ø,EP,GP,RZ	500	9,000	40

Make/Model	Years	PC	Part No.	Footnotes	Vert Load	Line Pull	In
CHEVROLET (continued)							
Silverado 3500 HD	11-14	24	65078	Ø,GP,EP	500	9,000	45
Silverado 3500 HD	15-17	24	65078	Ø,GP,EP	500	9,000	35
Suburban	15-19	30	65064	Ø,GP,X	500	9,000	25
Suburban 1500	00-06	47	65023		500	9,000	20
Suburban 1500 Except Z71	07-14	30	65052	Ø,GP,X	500	9,000	25
Suburban 2500	00-06	24	65028	HB	500	9,000	20
Suburban C1500	92-99	21	65005	JU,JV,KC	500	9,000	40
		46	65021†	JV,KD	500	9,000	30
Suburban C2500	92-99	21	65005	JU,JV,KC	500	9,000	40
		46	65021†	JV,KD	500	9,000	30
Suburban K1500	92-99	21	65005	JU,JV,KC	500	9,000	40
		46	65021†	JV,KD	500	9,000	30
Suburban K2500	92-99	21	65005	JU,JV,KC	500	9,000	40
		46	65021†	JV,KD	500	9,000	30
Tahoe	95-00	21	65005	JU,JV	500	9,000	40
Tahoe 1500 Series	00-06	47	65023		500	9,000	20
Tahoe Except Z71	07-14	30	65052	Ø,GP,X	500	9,000	25
Tahoe	15-19	30	65064	Ø,GP,X	500	9,000	25
DODGE							
Dakota 4 WD	00-04	42	65029†	Ø,JW	300	9,000	25
Durango 4 WD	00-03	42	65029†	Ø,JW	300	9,000	25
Ram 1500	94-01	37	65003	Ø,JV	500	9,000	30
Ram 1500	02-05	49	65033	Ø,GP	500	9,000	25
Ram 1500	09-10	32	65062	EP,GP	500	9,000	35
Ram 2500	94-02	37	65003	Ø,JV	500	9,000	30
Ram 2500	03-09	34	65046		500	9,000	40
Ram 2500	10	33	65063	Ø,GP,TY	500	9,000	30
Ram 2500 4 WD	10	35	65057	Ø,EP,GP,JW	500	9,000	40
Ram 3500	94-02	37	65003	Ø,JV	500	9,000	30
Ram 3500	03-09	34	65046		500	9,000	40
Ram 3500	10	38	65060	EP,GP	500	9,000	30
		33	65063	Ø,GP,TY	500	9,000	30
Ram 4500 Cab & Chassis	10	33	65063	Ø,GP,TY	500	9,000	30
Ram 5500 Cab & Chassis	10	33	65063	Ø,GP,TY	500	9,000	30
FORD							
E-150 Econoline	91-07	28	65001		500	9,000	20
E-150 Econoline	08-14	19	65053	EP,GP,JV	500	9,000	40
E-250 Econoline	91-07	28	65001		500	9,000	20
E-250 Econoline	08-14	19	65053	EP,GP,JV	500	9,000	40
Excursion	00-05	34	65022	AA,KI	500	9,000	40

FRONT MOUNTED RECEIVER HITCH APPLICATION GUIDE

Make/Model	Years	PC	Part No.	Footnotes	Vert Load	Line Pull	In
FORD (continued)							
E-350 Econoline Inc. RV Cutaway	91-07	28	65001		500	9,000	20
E-350 Econoline Super Duty	08-14	19	65053	AI,EP,GP,JV	500	9,000	50
E-350 Econoline Super Duty RV Cutaway	08-17	19	65053	AI,EP,GP,JV	500	9,000	50
E-450 Econoline Super Duty RV Cutaway	03-07	28	65001		500	9,000	20
E-450 Econoline Super Duty RV Cutaway	08-17	19	65053	AI,EP,GP,JV	500	9,000	50
E-450 Econoline Super Duty Stripped RV Cutaway	00-02	28	65001		500	9,000	20
Expedition	97-02	35	65025	Ø	500	9,000	20
Explorer	91-94	52	65017	Ø	300	9,000	35
Explorer 2 Dr. Sport	01-03	29	65030†	Ø	300	9,000	25
Explorer 4 Dr.	02-05	32	65032†		500	9,000	30
Explorer Sport Trac	01-05	29	65030†	Ø	300	9,000	25
F-150	97-03	35	65025	Ø	500	9,000	20
F-150	04-08	22	65043	Ø	500	9,000	20
F-150	09-14	34	65061	Ø,GP,JV,HB	500	9,000	30
F-150	15-19	31	65067	Ø,GP,JV	500	9,000	30
F-150 Heritage	04	35	65025	Ø	500	9,000	20
F-250	92-97	30	65015	Ø,JW	500	9,000	25
F-250 Styleside	92-97	32	65014	Ø,JT,KB	500	9,000	25
F-250 Styleside	97-98	35	65025	Ø,JW	500	9,000	20
F-250 Styleside	99	35	65025	Ø	500	9,000	20
F-250 Super Duty	99-07	34	65022	AA,KI	500	9,000	40
F-250 Super Duty	08-16	30	65049	Ø,GP,X	500	9,000	20
F-250 Super Duty	17-19	29	65076	Ø,JV	500	9,000	30
F-350	92-97	30	65015	Ø,JW	500	9,000	25
F-350 Styleside	92-97	32	65014	Ø,JT,KB	500	9,000	25
F-350 Super Duty	99-07	34	65022	AA,KI	500	9,000	40
F-350 Super Duty Cab & Chassis, with 34 Wide Frames	99-07	34	65022	AA,KI	500	9,000	40
F-350 Super Duty	08-16	30	65049	Ø,GP,X	500	9,000	20
F-350 Super Duty Cab & Chassis	08-16	30	65049	Ø,GP,X	500	9,000	20
F-350 Super Duty	17-19	29	65076	Ø,JV	500	9,000	30
F-450 Super Duty Cab & Chassis, with 34 Wide Frames	99-07	34	65022	AA,KI	500	9,000	40
F-450 Super Duty	08-16	30	65049	Ø,GP,X	500	9,000	20
F-450 Super Duty Cab & Chassis	08-16	30	65049	Ø,GP,X	500	9,000	20
F-450 Super Duty	17-19	29	65076	Ø,JV	500	9,000	30
F-550 Super Duty Cab & Chassis, with 34 Wide Frames	99-07	34	65022	AA,KI	500	9,000	40
F-550 Super Duty Cab & Chassis	08-16	30	65049	Ø,GP,X	500	9,000	20
Ranger	89-97	52	65017	Ø,JY	300	9,000	35
Ranger	01-05	31	65024		500	9,000	35
GMC							
C1500 2 Dr. Regular & Extended Cabs	88-99	21	65005	JU,JV,KC	500	9,000	40
		46	65021†	JV,KD,KE	500	9,000	30
C1500 4 Dr. Crew Cab	92-99	46	65021†	JV,KD,KE	500	9,000	30
K3500 4 Dr. Crew Cab	92-00	21	65005	JU,JV,KC	500	9,000	40

Make/Model	Years	PC	Part No.	Footnotes	Vert Load	Line Pull	In
GMC (continued)							
C2500 2 Dr. Regular & Extended Cabs	88-00	21	65005	JU,JV,KC	500	9,000	40
		46	65021†	JV,KD,KE	500	9,000	30
C2500 4 Dr. Crew Cab	92-00	46	65021†	JV,KD,KE	500	9,000	30
C3500 2 Dr. Regular & Extended Cabs	88-00	21	65005	JU,JV,KC	500	9,000	40
		46	65021†	JV,KD,KE	500	9,000	30
C3500 4 Dr. Crew Cab	92-00	46	65021†	JV,KD,KE	500	9,000	30
Canyon	15-16	23	65071	Ø,X	500	9,000	30
Jimmy Downsize	95-05	24	65004	JW,JX,X	300	9,000	30
K1500 2 Dr. Regular & Extended Cabs	88-99	21	65005	JU,JV,KC	500	9,000	40
K1500 4 Dr. Crew Cab	92-99	21	65005	JU,JV,KC	500	9,000	40
K2500 4 Dr. Crew Cab	92-00	21	65005	JU,JV,KC	500	9,000	40
Savana 1500 Inc. RV Cutaway	96-03	24	65016	X	500	9,000	35
Savana 2500 Inc. RV Cutaway	96-03	24	65016	X	500	9,000	35
Savana 3500 Inc. RV Cutaway	96-03	24	65016	X	500	9,000	35
Sierra 1500 Except Denali (Classic)	99-07	47	65023		500	9,000	20
Sierra 1500	07-13	30	65052	Ø,GP,X	500	9,000	25
Sierra 1500 LD (Old Body Style)	14-19	30	65064	Ø,GP,X	500	9,000	25
Sierra 1500 HD	01-07	24	65028	HB	500	9,000	20
Sierra 2500	99-04	24	65028	HB	500	9,000	20
Sierra 2500 HD	01-07	24	65028	HB	500	9,000	20
Sierra 2500 HD	07-10	22	65050	Ø,EP,GP,RZ	500	9,000	40
Sierra 2500 HD Except Denali	11-14	24	65078	Ø,GP,EP	500	9,000	45
Sierra 2500 HD Except Denali	15-19	24	65078	Ø,GP,EP	500	9,000	35
Sierra 3500	01-07	24	65028	HB	500	9,000	20
Sierra 3500 HD	07-10	22	65050	Ø,EP,GP,RZ	500	9,000	40
Sierra 3500 HD Except Denali	11-14	24	65078	Ø,GP,EP	500	9,000	45
Sierra 3500 HD Except Denali	15-17	24	65078	Ø,GP,EP	500	9,000	35
Sonoma	94-04	24	65004	JW,JX,X	300	9,000	30
Suburban C1500	92-99	21	65005	JU,JV,KC	500	9,000	40
		46	65021†	JV,KD	500	9,000	30
Suburban C2500	92-99	21	65005	JU,JV,KC	500	9,000	40
		46	65021†	JV,KD	500	9,000	30
Suburban K1500	92-99	21	65005	JU,JV,KC	500	9,000	40
		46	65021†	JV,KD	500	9,000	30
Suburban K2500	92-99	21	65005	JU,JV,KC	500	9,000	40
		46	65021†	JV,KD	500	9,000	30
Yukon	92-00	21	65005	JU,JV	500	9,000	40
Yukon 1500	00-06	47	65023		500	9,000	20
Yukon	07-14	30	65052	Ø,GP,X	500	9,000	25
Yukon	15-19	30	65064	Ø,GP,X	500	9,000	25
Yukon Denali 1500	01-06	47	65023		500	9,000	30
Yukon XL	15-19	30	65064	Ø,GP,X	500	9,000	25
Yukon XL 1500	00-06	47	65023		500	9,000	20
Yukon XL 1500	07-14	30	65052	Ø,GP,X	500	9,000	25
Yukon XL 1500 Denali	01-06	47	65023		500	9,000	30
Yukon XL 2500	00-06	24	65028	HB	500	9,000	20
HONDA							
Ridgeline	17	27	65073	HM,X,SV	500	9,000	35

FRONT MOUNTED RECEIVER HITCH APPLICATION GUIDE

Make/Model	Years	PC	Part No.	Footnotes	Vert Load	Line Pull	In
ISUZU							
Hombre	96-00	24	65004	JW,JX,X	300	9,000	30
JEEP							
Cherokee Downsized	84-01	23	65009	JV	300	9,000	30
Comanche	86-92	23	65009	JV	300	9,000	30
Gladiator	20	19	65079	Ø,DU,FE,GP,SV,	500	9,000	35
Grand Cherokee	93-98	53	65008	JV	300	9,000	25
Grand Wagoneer	93	53	65008	Ø,JV	300	9,000	25
TJ (Canada Only)	97-06	23	65048	Ø,X	300	9,000	25
Wagoneer	84-90	23	65009	JV	300	9,000	30
Wrangler	87-95	23	65048	Ø,X	300	9,000	25
Wrangler	97-06	23	65048	Ø,X	300	9,000	25
Wrangler	07-17	19	65069	Ø,EP,GP	500	9,000	40
Wrangler JL (New Body Style)	18-19	19	65079	Ø,DU,FE,GP,SV,	500	9,000	35
Wrangler JK	18	19	65069	Ø,EP,GP	500	9,000	40
YJ (Canada Only)	87-95	23	65048	Ø,X	300	9,000	25
LINCOLN							
Mark LT	06-08	22	65043	Ø	500	9,000	20
Mark LT (Mexico Only)	10-13	34	65061	Ø,GP,JV	500	9,000	30
Navigator	98-02	35	65025	Ø	500	9,000	20
MAZDA							
B2300	94-97	52	65017	Ø,JY	300	9,000	35
B2300	02-05	31	65024		500	9,000	35
B2500	01	31	65024		500	9,000	35
B3000	94-97	52	65017	Ø,JY	300	9,000	35
B3000	01-05	31	65024		500	9,000	35
B4000	94-97	52	65017	Ø,JY	300	9,000	35
B4000	01-05	31	65024		500	9,000	35
Navajo	91-94	52	65017	Ø,JY	300	9,000	35
MERCURY							
Mountaineer	02-05	32	65032†		500	9,000	30
NISSAN							
Frontier	05-19	24	65075	Ø	500	9,000	35
Pathfinder	05-12	24	65075	Ø	500	9,000	35
Titan Except Titan XD & 4 WD Models	17	30	65077	Ø,SV,GP,X	500	9,000	60
OLDSMOBILE							
Bravada	96-01	24	65004	JW,JX,X	300	9,000	30
RAM							
1500	11-18	32	65062	EP,GP	500	9,000	35
1500 (Classic)	19	32	65062	EP,GP	500	9,000	35
1500 (New Body Style), Except with Factory Tow Hooks	19	32	65081	Ø,JV,GP	500	9,000	50
2500	11-18	33	65063	Ø,GP,TY	500	9,000	30
2500 4 WD	11-12	35	65057	EP,GP,JW	500	9,000	40
3500	11-12	38	65060	EP,GP	500	9,000	30
3500	11-18	33	65063	Ø,GP,TY	500	9,000	30
4500 Cab & Chassis	11-18	33	65063	Ø,GP,TY	500	9,000	30
5500 Cab & Chassis	11-18	33	65063	Ø,GP,TY	500	9,000	30
SUZUKI							
Equator Sport & RMZ-4 Models	09-12	24	65075	Ø	500	9,000	35

Make/Model	Years	PC	Part No.	Footnotes	Vert Load	Line Pull	In
TOYOTA							
4Runner Except Limited	14-19	34	65074	Ø,HM	500	9,000	20
Sequoia	01-07	30	65031		500	9,000	40
Sequoia	07-19	16	65080	Ø,HM,KG	500	9,000	20
Tacoma	01-04	31	65041		500	9,000	30
Tacoma	05-19	52	65070	Ø,HM,KG	500	9,000	35
Tundra	00-06	30	65031		500	9,000	40
Tundra	07-17	16	65051†	Ø,HM,KG	500	9,000	25
Tundra	07-19	16	65080	Ø,HM,KG	500	9,000	20

FOOTNOTES:

- † - Available while supplies last.
- AA - Requires temporary removal of bumper during installation.
- AI - Additional installation time may be required. Additional installation time required for vehicles equipped with load leveling compressor.
- DU - Fascia removal required.
- EP - Fascia trimming may be required.
- FE - Fascia trimming may be required. Allow additional installation time.
- GP - Hitch cross tube concealed behind bumper.
- HB - Slight fascia deformation may occur on some models.
- HM - Hitch cross tube is visible beneath bumper.
- JT - 2WD models only.
- JU - License plate relocation required to install hitch see 5443. (Sold separately)
- JV - Rubber air deflector/fascia must be removed or trimmed to install hitch.
- JW - 4WD models only.
- JX - Requires factory tow hooks for installation on 2WD models.
- JY - Extensive fascia cutting required on models with fog lamp option.
- KB - Diesel engine models only.
- KC - Does not fit 2500/3500 2WD (C-Series) models with 8 lug wheels.
- KD - Fits 2500/3500 2WD (C-Series) models with 8 lug wheels only.
- KE - Does not fit 1988-91 4 Dr. Crew Cab models.
- KG - Skid shield must be removed or modified if present.
- KI - Optional OEM Fog Lights must be removed for receiver installation.
- Ø - Uses all existing holes. No drilling required.
- RB - Hitch installation can be made easier with a cutter type drill bit.
- RZ - License plate holder relocation and/or modification required to install hitch (see #49802 or #5443 Sold separately).
- SV - Trimming or removal of under body appearance panel may be required.
- TY - Requires factory tow hooks for installation.
- X - Minor fascia trimming required.

RECEIVER HITCH APPLICATION GUIDE

Draw-Tite® hitch application guide enables you to find the right towing system components each and every time. These pages have been developed to simplify the look-up of the proper hitch and drawbar, for your customer's vehicle by make, model and year.

F	RECEIVER HITCH APPLICATION GUIDE											
	YEAR	PC	REC TYPE	REC SIZE	PART NO.	NO DRILL	FOOTNOTES	OPTIONAL DRAWBAR	WC (LBS.)	WD (LBS.)	IN	
FORD	TRAILER HITCHES											
	FORD (Continued)											
	F-250 Super Duty Except Cab & Chassis	99-01	49	RT3	2	37133				500/5,000	750/7,500	30
			54	RT4	2	37130				700/7,000	1,200/12,000	30
			27	RT4	2	75740	0	FP,HM		900/6,000	1,000/10,000	20
			51	SQ5	2	41922	0	@,GP		1,000/10,000	1,200/12,000	15
			55	SQ5	2	41931	0	@,HM,SH		1,200/12,000	1,500/15,000	30
		60	SQ5	2-1/2	45508	0	#,CS,EF,HM,LT,M		2,000/18,000	2,500/18,000	50	
	F-250 Super Duty Except Cab & Chassis, w/Factory 7-Way	99-16										
	F-250 Super Duty w/Deep Drop Bumper	99-01	70	SQ5	2-1/2	45514	0	#		1,200/12,000	1,700/14,000	20
	F-250 Super Duty w/Deep Drop Bumper, w/Factory 7-Way	99-04										
	F-250 Super Duty Except Cab & Chassis	02-04	49	RT3	2	37133				500/5,000	750/7,500	30
54			RT4	2	37130				700/7,000	1,200/12,000	30	
27			RT4	2	75740	0	FP,HM		900/6,000	1,000/10,000	20	
51			SQ5	2	41922	0	@,GP		1,000/10,000	1,200/12,000	15	
55			SQ5	2	41931	0	@,HM,SH		1,200/12,000	1,500/15,000	30	
	60	SQ5	2-1/2	45508	0	#,CS,EF,HM,LT,M		2,000/18,000	2,500/18,000	50		
F-250 Super Duty w/Deep Drop Bumper	02-04	70	SQ5	2-1/2	45514	0	#		1,200/12,000	1,700/14,000	20	
F-250 Super Duty Except Cab & Chassis	05-07	27	RT4	2	75740	0	FP,HM		900/6,000	1,000/10,000	20	
		55	SQ5	2	41931	0	@,EB,HM,SH		1,200/12,000	1,500/15,000	30	
		60	SQ5	2-1/2	45508	0	#,CS,EF,HM,LT,M		2,000/18,000	2,500/18,000	50	
F-250 Super Duty Except Cab & Chassis	08-16	55	SQ5	2	41931	0	@,EB,HM,SH		1,200/12,000	1,500/15,000	30	
		60	SQ5	2-1/2	45508	0	#,CS,EF,HM,LT,M		2,000/18,000	2,500/18,000	50	
F-250 Super Duty Except Cab & Chassis, w/Factory 7-Way	17-19											

1). VEHICLE MODEL/STYLE & YEAR RANGE

Applications are separated first by make, and subsequently by model and yearly divisions.

2). HITCH FOOTNOTES

Footnotes reference additional information pertinent to the installation and availability of a particular hitch. Common footnotes such as GP (hitch crosstube concealed behind bumper) are listed at the bottom of each left hand page.

3). DRAW-TITE® HITCH PART NUMBERS

Class I, II, III, IV and V receiver hitches are specific for each individual vehicle. This listing indicates the correct hitch by application.

4). DRAWBAR PART NUMBERS

Class I and Class II drawbars are specific for each individual vehicle. This listing indicates the correct drawbar (sold separately) by application.

5). PRICE CODES

Price codes reference specific prices found on Hitch and Accessory Price List.

6). RECEIVER TYPE

Receiver Type codes are referenced in a Receiver Type footnote box at the bottom of each right hand page.

7). NO DRILL

Ø - No drilling requires.

8). RECEIVER WEIGHT RATINGS

WC or Weight Carrying, refers to the total load the hitch is capable of pulling, without the use of a weight distributing system. WD or Weight Distributing, is the total load capacity of the hitch when a weight distribution system is properly utilized.

9). RECEIVER SIZE

Receiver sizes range from 1-1/4 in. to 3 in.

10). INSTALLATION TIME

Average installation times (IN) are listed in minutes and are published for all hitches and T-One® wiring connectors. Times are based on common mechanical practices and should be used as an estimate as actual installation times may vary in each individual situation.

11). ELECTRICAL TYPE

Referenced in the footnotes at the bottom of each right hand page, electrical type codes assist in determining the proper electrical wiring products for the towing vehicle.

12). ELECTRICAL POSITIONS

Determining the location of tow vehicle's wiring is becoming increasingly difficult on today's modern vehicles.

NOTE: See Electrical Reference Guide.

ELECTRICAL APPLICATION GUIDE

Tekonsha® electrical application guide enables you to find the right towing system components each and every time. These pages have been developed to simplify the look-up of the proper electrical connectors and wiring locations for your customer's vehicle by make, model and year

ELECTRICAL APPLICATION GUIDE																	F					
T-ONE			TOW HARNESS				4-FLAT WIRING			REQ. 4 FLAT WIRING			BRAKE CONTROL HARNESS		IN							
PC	T-ONE	FN	IN	AMP	CP	PC	TOW HARN	FN	IN	AMP	CP	TYPE	ELEC	POS		CHOICE 1	CHOICE 2	6-WAY ADAPTER	7-WAY ADAPTER	7-WAY HARDWARE	3035-P	3035-P
FORD (Continued)																						
						E15	118243	BN,RD	5			7-Way	A	PU1,2	119148	20252	20320	20321	20224	3035-P	5	
							74682	RD	10			Both	A	PU3	119148	20252						
							85219	RD	5			7-Way										
						E15	118243	BN,RD	5			7-Way	A	PU1,2	119148	20252	20320	20321	20224	3035-P	5	
							74682	RD	10			Both	A	PU3	119148	20252						
							85219	RD	5			7-Way										
													A	PU1,2	119148	20252	20320	20321	20224	3035-P	5	
													A	PU1,2	119148	20252	20320	20321	20224	3065-P	5	
													A	PU1,2	119148	20252	20320	20321	20224	3034-P	20	

13). T-ONE® PART NUMBERS

T-One® part numbers are for vehicle specific applications.

14). TOW HARNESS PART NUMBERS

OEM replacement harness part numbers are for vehicle specific applications with factory tow packages.

15). ELECTRICAL FOOTNOTES

Footnotes reference additional information pertinent to the installation and availability of a particular electrical harness. Footnotes are listed at the bottom of each right hand page.

16). AMPERAGE RATING

Amp Rating references the maximum number of amps the Electrical Product will hold for the tow vehicle.

- Stop-Turn Lights - 2 Amps Each
- Tail Lights - 1 Amp Each
- Clearance and Marker Lights - 1/4 to 1/2 Amp Each

17). CIRCUIT PROTECTION

Tekonsha recommends circuit protection on vehicles with 3 wire systems for extra safety.

18). OEM CONNECTOR TYPE

Tow Harness Connector type references the type of connector. Example: 4-Flat.

19). HARDWARE CHOICE 1

The ModuLite® with short circuit protector, adds integrated short circuit protection that safeguards itself and the tow vehicle against harmful electrical shorts and mis-wire situations.

20). HARDWARE CHOICE 2

Easy do-it-yourself tow vehicle wiring kits.

21). 6-WAY ADAPTERS

Used to convert any trailer wiring component, T-One® or tail light converter with a 4-Flat car end connector to a 6-Way round connector.

22). 7-WAY ADAPTERS

Used to convert any trailer wiring component, T-One® or tail light converter with a 4-Flat car end connector to a 7-Way round connector.

23). 7-WAY HARDWARE

Easy do-it-yourself tow vehicle 7-Way connector wiring kit.

24). BRAKE CONTROL HARNESSES

Brake control harnesses are vehicle specific and designed for quick, easy installation.

RECEIVER HITCH APPLICATION GUIDE

MODEL / STYLE	YEAR	TRAILER HITCHES									
		PC	REC TYPE	REC SIZE	PART NO.	NO DRILL	FOOTNOTES	OPTIONAL DRAWBAR	WC (LBS.)	WD (LBS.)	IN
ACURA											
CL 3.2	01-03	18	SQ1	1-1/4	24791	0	JR,HM	3592	200/2,000		15
CSX (Canada Only)	06-11	27	SQ1	1-1/4	24861	0	HM,JR,KH,SV	3593	200/2,000		30
EL (Canada Only)	97-01	29	SQ1	1-1/4	24677	0	HM	3593	200/2,000		15
ILX Except Hybrid	13-19	27	SQ1	1-1/4	24861	0	HM,JR,KH,SV	3593	200/2,000		35
Integra	94-01	22	SQ1	1-1/4	24589	0	HM	3593	200/2,000		40
MDX Except w/Full Size Spare Tire	01-06	31	SQ3	2	75599	0	GP,JR		350/3,500	500/5,000	30
MDX Except w/Full Size Spare Tire or w/Rear Sport Bumper Option	07-12	47	RT3	2	75614	0	CR,JR		400/4,000	500/5,000	35
MDX Except w/Full Size Spare Tire or w/Rear Sport Bumper Option	13	47	RT3	2	75614	0	CR,JR		400/4,000	500/5,000	35
MDX Except w/Full Size Spare Tire	14-19	37	SQ4	2	75225	0	TA,GP		900/6,000	900/8,000	20
RDX	07-09	21	SQ2	1-1/4	36427	0	GP	36061	300/3,500		15
		33	SQ3	2	75563	0	GP		400/4,000		30
RDX	10-12	19	SQ3	2	75784	0	GP		400/4,000		30
RDX	13-18	19	SQ3	2	75784	0	GP		400/4,000		30
RDX With +12V Power Provision	19-20	17	SQ2	1-1/4	36114	0	J,JR	36051	300/3,500		30
		19	RT3	2	76268	0	JR,J		350/3,500		25
RDX Without +12V Power Provision	19-20	17	SQ2	1-1/4	36114	0	JR,J		300/3,500		25
		19	RT3	2	76268	0	JR,J		350/3,500		25
RL 3.5	96-01	41	SQ2	1-1/4	362261		GP	36061	300/3,500		30
RL 3.5	02-04	41	SQ2	1-1/4	362261		GP	36061	300/3,500		30
RLX	14-17	46	SQ2	1-1/4	36541	0	DU,EP,GP,SV,TA	36071	300/3,500		60
RLX	18-19	46	SQ2	1-1/4	36541	0	DU,EP,GP,SV,TA	36071	300/3,500		60
RSX	02-06	20	SQ1	1-1/4	24719		TA,GP	3593	200/2,000		30
SLX	96-99	41	SQ3	2	750431		HM		500/5,000	750/7,500	40
TL 3.2	99-03	18	SQ1	1-1/4	24791	0	JR,HM	3592	200/2,000		15
TL	04-08	18	SQ1	1-1/4	24755		TA,GP	3594	200/2,000		35
TL	09-14	19	SQ1	1-1/4	24899	0	HM,JR,KH,SV	3593	200/2,000		45
TLX	15-19	29	SQ1	1-1/4	24942	0	DU,EP,GP,TA	3593	200/2,000		60
TSX 4 Dr. Sedan	06-08	25	SQ1	1-1/4	247681	0	HM,JR	3593	200/2,000		40
TSX 4 Dr. Sedan	09-14	19	SQ1	1-1/4	24899	0	HM,JR,KH,SV	3593	200/2,000		45
ZDX	10-13	25	SQ1	1-1/4	248541	0	GP,I	3590	200/2,000		25
ALFA ROMEO											
Stelvio Except Quadrifoglio	18	47	SQ3	2	76199	0	GP,DU,X,TA,TZ,TW		600/4,000		80
AUDI											
A3 Except Sportback e-tron	15-19	27	SQ1	1-1/4	24930	0	GP	3594	200/2,000		20
A4 4 Dr. Sedan	09-16	29	SQ1	1-1/4	248301	0	EP,GP	3593	200/2,000		25
A4 4 Dr. Sedan	09-19	23	SQ1	1-1/4	24950	0	X,GP,SV	3593	200/2,000		25
A6 4 Dr. Sedan	05-11	25	SQ1	1-1/4	24836	0	HM,JR	3593	200/2,000		25
A6 Quattro Avant Wagon	06-10	25	SQ1	1-1/4	24836	0	HM,JR	3593	200/2,000		25
Q3	13-18	40	SQ3	2	75218	0	DU,EP,GP		450/4,500		50
Q5	11-12	34	SQ3	2	75940	0	DU,EP,GP,TA		750/5,000		60
Q5	13-17	34	SQ3	2	75940	0	DU,EP,GP,TA		750/5,000		60
Q5	18-19	34	SQ3	2	76183	0	GP,DU,X,TA,TZ,TW		750/5,000		90
Q7	07-16	45	SQ4	2	75950	0	AI,GP,X		750/7,500		70
Q7	17-18	34	SQ4	2	76076	0	X,DU,GP		770/7,700		60
SQ5	18	34	SQ3	2	76183	0	GP,DU,X,TA,TZ,TW		750/5,000		90
BMW											
320i	12-14	24	SQ1	1-1/4	24945	0	DU,GP,SV,KH	3593	200/2,000		50
320i	15	24	SQ1	1-1/4	24945	0	DU,GP,SV,KH	3593	200/2,000		50
320i	16-17	24	SQ1	1-1/4	24945	0	DU,GP,SV,KH	3593	200/2,000		50
320i	18										
320i xDrive	12-14	24	SQ1	1-1/4	24945	0	DU,GP,SV,KH	3593	200/2,000		50

AI Additional installation time may be required.

CR Fits with mini spare tire stowed under vehicle. Will not fit with full size spare.

DU Fascia removal required.

EP Fascia trimming may be required.

GP Hitch cross-tube concealed behind bumper.

HM Hitch cross-tube is visible beneath bumper.

I Hitch is positioned further rearward to accommodate spare tire.

J Under vehicle spare tire stowage is retained.

JR Exhaust must be temporarily lowered for installation.

KH Minor heat shield modification may be required.

SV Trimming or removal of under body appearance panel may be required.

TA Trunk access required for hitch installation.

TW Receiver hitch may limit hands-free liftgate sensor range

TZ Requires replacement of the impact structure with hitch.

X Minor fascia trimming required.

T-ONE						TOW HARNESS						4-FLAT WIRING				REQ. 4 FLAT WIRING			7-WAY HARDWIRE	BRAKE CONTROL HARNESS	IN
PC	T-ONE	FN	IN	AMP	CP	PC	TOW HARN	FN	IN	AMP	CP	TYPE	ELEC	POS	CHOICE 1	CHOICE 2	6-WAY ADAPTER	7-WAY ADAPTER			
ACURA																					
E5	118336	HG	5	2.1,5									B	PC3	119130	119178					
													B,E	PC3,4	119191	119148					
													B	PC3	119130	119178					
E18	118627	CH	45	2.1,5,6	X								B,E	PC1,2	119191	119148					
E5	118336	HG	5	2.1,5									B	PC3	119130	119178					
E5	118336	HG	5	2.1,5									B	SUV3	119130	119178	20320	20321	20224		
E11	118424	CH	20	2.1,4,2	X								B,E	SUV1,2	119191	119148	20320	20321	20224		
E11	118424	CH	20	2.1,4,2	X								B,E	SUV1,2	119191	119148	20320	20321	20224	3028-P	5
E11	118628	BN,CH	20	4.2,7,5	X	E23	118289	BN,CH	30	4.2,12	X	7-Way	B,E	SUV3,4	119191	119148	20320	20321	20224	3028-P	5
E11	118500	CH	15	2.1,5,6	X								B,E	SUV1,2	119191	119148	20320	20321	20224		
E11	118500	CH	15	2.1,5,6	X								B,E	SUV1,2	119191	119148	20320	20321	20224		
E14	118569	CH	15	4.2,7,5	X								B,E	SUV1,2	119191	119148	20320	20321	20224		
E12	118800	CH	25	5.7,5	X								B,E	SUV3	119191	119148	20320	20321	20224		
E13	118804		45	5.7,5	X								B,E	SUV3	119191	119148	20320	20321	20224		
E5	118336	HG	5	2.1,5									B	PC3	119130	119178					
													B	PC3	119130	119178					
E16	118626	CH	45	2.1,5,6	X								B,E	PC3,4	119191	119148	20320	20321	20224		
													B,E	PC3,4	119191	119148					
													B	PC3	119130	119178					
E5	118339	BN,HG	5	2.1,5									B	SUV5	119130	119178	20320	20321	20224		
E5	118336	HG	5	2.1,5									B	PC3	119130	119178					
E10	118489	HG	10	2.1,7,5									B,E	PC3,4	119191	119148					
E19	118537	CH	45	2.1,5,6	X								B,E	PC3,4	119191	119148					
E18	118697	CH	45	5.7,5	X								B,E	PC1,2	119191	119148					
E11	118302	HG	10	2.1,4,2									B	PC3	119130	119178					
E14	118420	CG	15	2.1,5	X								B,E	PC3,4	119191	119148					
E13	118503	CH	30	2.1,5,6	X								B,E	SUV9	119191	119148					
ALFA ROMEO																					
E22	118777	CH	45	5.7,5	X								A,E	SUV1,2							
AUDI																					
													C,E	PC3,4	119191	119148					
													BTT	PC1,2	119251	119191					
													BTT	PC1,2	119192	119191					
													BT	PC1,2	119251	119191					
													BM	PC1,2	119251	119191					
													BT	SUV9	119251	119191					
													BT	SUV1,2	119251	119191	20320	20321	20224		
													A,E	SUV1,2	119191	119148	20320	20321	20224		
													A,E	SUV3	119191	119148	20320	20321	20224		
													B,E	SUV1,2	119191	119148	20320	20321	20224		
													B,E	SUV1,2	119191	119148					
													A,E	SUV3	119191	119148	20320	20321	20224		
BMW																					
													B,M	PC3,4	119251	119191					
													B,E	PC3,4	119191	119148					
E23	118713	CH,BN	45	4.2,7,5	X								B,E	PC3,4	119191	119148					
E23	118713	CH,BN	45	4.2,7,5	X								B,E	PC3,4							
													BM	PC3,4	119251	119191					

- A** 2 wire system.
- B** 3 wire system. Converter required.
- BM** Multiplexed wiring system. ModuLite® HD Plus or Ultra required.
- BN** Exterior mounted plug on some or all models. May require an aftermarket electrical mounting box or bracket. (Sold separately)
- BT** Shared Brake/Tail multiplexed wiring system. ModuLite® HD Plus or Ultra required.
- BTT** Shared Brake/Tail/Turn multiplexed wiring system. ModuLite® HD Plus or Ultra required.
- C** 2 or 3 wire system determine at installation.
- CG** T-One incorporates circuit protected taillight converter.
- CH** T-One is equipped with circuit protected ModuLite® module.
- E** ModuLite® required.
- HG** T-One incorporates taillight converter.
- M** Will fit with heavy-duty suspension.

- RT3** Round Tube Class III 2"
- SQ1** Square Tube Class I
- SQ2** Square Tube Class II
- SQ3** Square Tube Class III
- SQ4** Square Tube Class IV

BMW

RECEIVER HITCHES

RECEIVER HITCH APPLICATION GUIDE

MODEL / STYLE	YEAR	TRAILER HITCHES									
		PC	REC TYPE	REC SIZE	PART NO.	NO DRILL	FOOTNOTES	OPTIONAL DRAWBAR	WC (LBS.)	WD (LBS.)	IN
BMW (Continued)											
320i xDrive	15	24	SQ1	1-1/4	24945	0	DU,GP,SV,KH	3593	200/2,000		50
320i xDrive	16-17	24	SQ1	1-1/4	24945	0	DU,GP,SV,KH	3593	200/2,000		50
328d	12-14	24	SQ1	1-1/4	24945	0	DU,GP,SV,KH	3593	200/2,000		50
328d	15	24	SQ1	1-1/4	24945	0	DU,GP,SV,KH	3593	200/2,000		50
328d	16	24	SQ1	1-1/4	24945	0	DU,GP,SV,KH	3593	200/2,000		50
328d xDrive Sedan	12-14	24	SQ1	1-1/4	24945	0	DU,GP,SV,KH	3593	200/2,000		50
328d xDrive Sports Wagon	12-16	24	SQ1	1-1/4	24945	0	DU,GP,SV,KH	3593	200/2,000		50
328d xDrive Sedan	15	24	SQ1	1-1/4	24945	0	DU,GP,SV,KH	3593	200/2,000		50
328d xDrive Sedan	16	24	SQ1	1-1/4	24945	0	DU,GP,SV,KH	3593	200/2,000		50
328i Sedan	07-11	43	SQ1	1-1/4	24857	0	GP,SV	3593	200/2,000		45
328i Sedan	12-14	24	SQ1	1-1/4	24945	0	DU,GP,SV,KH	3593	200/2,000		50
328i Sedan	15	24	SQ1	1-1/4	24945	0	DU,GP,SV,KH	3593	200/2,000		50
328i Sedan	16	24	SQ1	1-1/4	24945	0	DU,GP,SV,KH	3593	200/2,000		50
328i GT xDrive	16										
328i xDrive Sedan	07-11	43	SQ1	1-1/4	24857	0	GP,SV	3593	200/2,000		45
328i xDrive	16										
328xi Sedan	07-08	43	SQ1	1-1/4	24857	0	GP,SV	3593	200/2,000		45
330e	16										
330i	16										
335i xDrive Sedan	12-14	24	SQ1	1-1/4	24945	0	DU,GP,SV,KH	3593	200/2,000		50
340i	16										
340i xDrive	16										
528i	15-16	32	SQ1	1-1/4	24936	0	GP,SV,TA,AA	3593	200/2,000		50
528i xDrive	15-16	32	SQ1	1-1/4	24936	0	GP,SV,TA,AA	3593	200/2,000		50
535d	15-16	32	SQ1	1-1/4	24936	0	GP,SV,TA,AA	3593	200/2,000		50
535d xDrive	15-16	32	SQ1	1-1/4	24936	0	GP,SV,TA,AA	3593	200/2,000		50
535i	15-16	32	SQ1	1-1/4	24936	0	GP,SV,TA,AA	3593	200/2,000		50
535i GT	15-17	32	SQ1	1-1/4	24936	0	GP,SV,TA,AA	3593	200/2,000		50
535i GT xDrive	15-17	32	SQ1	1-1/4	24936	0	GP,SV,TA,AA	3593	200/2,000		50
535i xDrive	15-16	32	SQ1	1-1/4	24936	0	GP,SV,TA,AA	3593	200/2,000		50
550i	15-16	32	SQ1	1-1/4	24936	0	GP,SV,TA,AA	3593	200/2,000		50
550i GT	15	32	SQ1	1-1/4	24936	0	GP,SV,TA,AA	3593	200/2,000		50
550i GT xDrive	15-16	32	SQ1	1-1/4	24936	0	GP,SV,TA,AA	3593	200/2,000		50
550i xDrive	15-16	32	SQ1	1-1/4	24936	0	GP,SV,TA,AA	3593	200/2,000		50
X1 w/Panoramic Moonroof	13-14	33	SQ3	2	75761	0	GP,JP		400/3,500	400/4,000	60
X1 w/Panoramic Moonroof	15	33	SQ3	2	75761	0	GP,JP		400/3,500	400/4,000	60
X1	16-17	25	SQ3	2	76018		GP,JP,DU,KH		675/4,500	675/4,500	40
X1	18-19	25	SQ3	2	76018		GP,JP,DU,KH		675/4,500	675/4,500	40
X2	18	35	SQ3	2	76200	0	GP,AA,TA		525/3,500		80
X3	04-10	25	SQ3	2	75371		AA,EP		350/3,500	400/4,000	100
X3	11-17	36	SQ3	2	75768†	0	GP,SV		400/3,500	400/4,000	90
X3	11-19	36	SQ3	2	76226	0	DU,AA,GP,SV,TA		750/5,000		75
X5	00-06	28	SQ4	2	75492		AA,EP		600/6,000	600/6,000	60
X5 Except M Sport Package	07-18	51	SQ4	2	75600	0	AA,EP,GP		600/6,000	600/6,000	75
X5 Except M Sport Package	19	51	SQ3	2	76288	0	GP,JP,AA,EP,DU,TA		720/7,200	720/7,200	90
BUICK											
Allure (Canada Only)	05-09	37	SQ2	1-1/4	36374		GP,JP	36061	300/3,500		30
Cascada	16-17	28	SQ1	1-1/4	24955	0	HM	3593	200/2,000		15
Century Sedan	97-05	24	SQ1	1-1/4	24659		TA,GP	3592	200/2,000		30
		37	SQ2	1-1/4	36374		GP,JP	36061	300/3,500		30
Enclave	08-12	19	RT3	2	75528	0	GP,JP,TN		750/5,000	750/7,500	25

AA Requires temporary removal of bumper during installation.
DU Fascia removal required.
EP Fascia trimming may be required.
GP Hitch crosstube concealed behind bumper.
HM Hitch crosstube is visible beneath bumper.

JR Exhaust must be temporarily lowered for installation.
KH Minor heat shield modification may be required.
SV Trimming or removal of under body appearance panel may be required.
TA Trunk access required for hitch installation.
TN Hitches produced before 07/09/12 are rated at 500/5000 WC & 500/5000 WD.

T-ONE						TOW HARNESS						4-FLAT WIRING				REQ. 4 FLAT WIRING			7-WAY HARDWIRE	BRAKE CONTROL HARNESS	IN
PC	T-ONE	FN	IN	AMP	CP	PC	TOW HARN	FN	IN	AMP	CP	TYPE	ELEC	POS	CHOICE 1	CHOICE 2	6-WAY ADAPTER	7-WAY ADAPTER			
BMW (Continued)																					
E23	118713	CH,BN	45	4.2,7.5	X								B,E	PC3,4	119191	119148					
													B,E	PC3,4	119191	119148					
													BM	PC3,4	119251	119191					
													B,E	PC3,4	119191	119148					
E23	118713	CH,BN	45	4.2,7.5	X								B,E	PC3,4	119191	119148					
													BM	PC3,4	119251	119191					
													BM	PC3,4	119251	119191					
													B,E	PC3,4	119191	119148					
E23	118713	CH,BN	45	4.2,7.5	X								B,E	PC3,4	119191	119148					
													B,E	PC3,4	119191	119148					
													BM	PC3,4	119251	119191					
E23	118713	CH,BN	45	4.2,7.5	X								B,E	PC3,4	119191	119148					
E23	118713	CH,BN	45	4.2,7.5	X								B,E	PC3,4	119191	119148					
													BM	PC3,4	119251	119191					
E23	118713	CH,BN	45	4.2,7.5	X								B,E	PC3,4	119191	119148					
E23	118713	CH,BN	45	4.2,7.5	X								B,E	PC3,4	119191	119148					
													BM	PC3,4	119251	119191					
E23	118713	CH,BN	45	4.2,7.5	X								B,E	PC3,4	119191	119148					
E23	118713	CH,BN	45	4.2,7.5	X								B,E	PC3,4	119191	119148					
													BTT	PC1,2	119251	119191					
													BTT	PC1,2	119251	119191					
													BTT	PC1,2	119251	119191					
													BTT	PC1,2	119251	119191					
													BTT	PC1,2	119251	119191					
													BTT	PC1,2	119251	119191					
													BTT	PC1,2	119251	119191					
													BTT	PC1,2	119251	119191					
													BTT	PC1,2	119251	119191					
													BTT	PC1,2	119251	119191					
													BTT	PC1,2	119251	119191					
													BTT	PC1,2	119251	119191					
													BTT	PC1,2	119251	119191					
													BTT	PC1,2	119251	119191					
													BTT	PC1,2	119251	119191					
													BTT	PC1,2	119251	119191					
													BTT	PC1,2	119251	119191					
													BTT	PC1,2	119251	119191					
E23	118717	BN	45		X								BM	SUV1,2	119251	119191	20320	20321	20224		
E23	118717	BN	45		X								B,E	SUV1,2	119251	119191	20320	20321	20224		
													B,E	SUV1,2	119251	119191	20320	20321	20224		
E21	118789	BN,CH	45	5.7.5	X								B,E	SUV1,2							
													BM	SUV3,4	119251	119191	20320	20321			
													BM	SUV1,2	119251	119191	20320	20321	20224		
													BM	SUV1,2	119251	119191	20320	20321	20224		
													BT	SUV3,4	119251	119191	20320	20321			
													E	SUV3,4	119191	119148	20320	20321	20224		
													B,E	SUV1,2	119191	119251					
BUICK																					
													A	PC3,4	119148	20252					
													B,E	PC1,2							
													A	PC3,4	119148	20252					
E7	118450	BN	10	7.5		E8	118384	BN,RD	5	7.5		4-Flat	N	SUV1,2		119251	20320	20321		3026-P	5

A 2 wire system.
B 3 wire system. Converter required.
BM Multiplexed wiring system. ModuLite® HD Plus or Ultra required.
BN Exterior mounted plug on some or all models. May require an aftermarket electrical mounting box or bracket. (Sold separately)
BT Shared Brake/Tail multiplexed wiring system. ModuLite® HD Plus or Ultra required.

BTT Shared Brake/Tail/Turn multiplexed wiring system. ModuLite® HD Plus or Ultra required.
CH T-One is equipped with circuit protected ModuLite® module.
E ModuLite® required.
N DO NOT cut or splice vehicle wiring. Only use approved T-One or see auto dealer for trailer tow wiring kit.
RD For vehicles equipped with factory tow package may require additional components or may be used as a replacement harness.

RT3 Round Tube Class III 2"
SQ1 Square Tube Class I
SQ2 Square Tube Class II
SQ3 Square Tube Class III
SQ4 Square Tube Class IV

RECEIVER HITCH APPLICATION GUIDE

MODEL / STYLE	YEAR	TRAILER HITCHES									
		PC	REC TYPE	REC SIZE	PART NO.	NO DRILL	FOOTNOTES	OPTIONAL DRAWBAR	WC (LBS.)	WD (LBS.)	IN
BUICK (Continued)											
Enclave w/Factory 7-Way	08-12										
Enclave	13-17	19	RT3	2	75528	0	GP, JR, TN		750/5,000	750/7,500	25
Enclave	18-19	30	SQ3	2	76184	0	DU, JR		750/5,000	750/5,000	75
Encore	13-16	25	RT2	1-1/4	36554	0	HM, JR	36061	300/3,500		40
Encore	17-19	25	RT2	1-1/4	36554	0	HM, JR	36061	300/3,500		40
Envision	16-18	24	SQ3	2	76080	0	AA, DU, GP, TA		675/4,500		45
Envision	19					0	AA, DU, GP, TA				45
		24	SQ3	2	76300	0	GP		675/4,500		25
LaCrosse Except Super	05-09	37	SQ2	1-1/4	36374		GP, JR	36061	300/3,500		30
LaCrosse	10-13	46	SQ2	1-1/4	36522†		HM	36061	300/3,500		25
LaCrosse	10-16	42	SQ2	1-1/4	36538	0	HM	36061	300/3,500		35
LaCrosse AWD	10-12	58	SQ2	1-1/4	36519†		†, HM	36061	300/3,500		25
LaCrosse FWD	10-12	58	SQ2	1-1/4	36519†	0	†, HM	36061	300/3,500		20
LaCrosse	14	47	SQ2	1-1/4	36546†		HM	36061	300/3,500		30
LaCrosse	17-19	23	SQ2	1-1/4	36594†	0	GP, JR, AA, DU, X, TA	36071	300/3,500		80
		20	SQ2	1-1/4	36652	0	GP, JR, AA, DU, X, TA	36071	350/3,500		80
LeSabre FWD	97-99	43	SQ2	1-1/4	36216†		GP, JR	36061	300/3,500		40
LeSabre	00-05	39	SQ2	1-1/4	36309		HM, JR	36063	300/3,500		30
Lucerne Except Super & Special Edition	06-09	39	SQ2	1-1/4	36309		HM, JR, KH	36063	300/3,500		30
Lucerne Super & Special Edition	08-09	25	SQ2	1-1/4	36502	0	HM, JR	36063	300/3,500		25
Lucerne	10-11	25	SQ2	1-1/4	36502	0	HM, JR	36063	300/3,500		25
Park Avenue	97-04	47	SQ2	1-1/4	36245		JR, GP	36061	300/3,500		40
Rainier w/Factory 7-Way	04-07										
Regal (App. starts with 97-1/2)	97-04	27	SQ1	1-1/4	24660	0	TA, GP	3594	200/2,000		20
		51	SQ2	1-1/4	36241		JR, GP	36065	300/3,500		35
Regal	11-13	42	SQ2	1-1/4	36538	0	HM	36061	300/3,500		35
Regal Except GS	11-13	58	SQ2	1-1/4	36519†	0	†, HM	36061	300/3,500		20
		46	SQ2	1-1/4	36522†	0	HM	36061	300/3,500		20
Regal	14-17	42	SQ2	1-1/4	36538	0	HM	36061	300/3,500		35
Regal Sportback	18-19	20	SQ2	1-1/4	36652	0	GP, JR, AA, DU, X, TA	36071	350/3,500		80
Regal TourX	18-19										
		41	SQ2	1-1/4	36661	0	EP, GP, JR, KH	36071	350/3,500		30
Rendezvous	02-07	34	SQ2	1-1/4	36425		HM	36071	300/3,500		40
		32	SQ3	2	75138	0			350/3,500		55
		28	SQ3	2	75430		HM		350/3,500		40
Terraza	05-07	27	SQ2	1-1/4	36361		AL, GP, JR	36061	300/3,500		40
		22	SQ3	2	75278		AL, GP, JR		350/3,500	500/5,000	40
Verano Except Turbo or w/Dual Exhaust	12-17	18	SQ1	1-1/4	24882	0	AW, GP, JR, KH, QW	3593	200/2,000		40
CADILLAC											
ATS Except ATS-V	13-19	29	SQ1	1-1/4	24924	0	GP	3594	200/2,000		30
CTS	03-07	33	SQ1	1-1/4	24767		JR, TA, HM	3594	200/2,000		45
CTS 4 Dr. Sedan	08-13	33	SQ1	1-1/4	24767		JR, TA, HM	3594	200/2,000		45
CTS 4 Dr. Sedan	14-15	30	SQ1	1-1/4	24927		GP, JR, KH, TA	3593	200/2,000		60
CTS 4 Dr. Sedan, Except CTS-V	16-19	30	SQ1	1-1/4	24927		GP, JR, KH, TA	3593	200/2,000		60
CTS V	04-07	33	SQ1	1-1/4	24767		JR, TA, HM	3594	200/2,000		45
CTS V 4 Dr. Sedan	09-13	33	SQ1	1-1/4	24767		JR, TA, HM	3594	200/2,000		45
DeVille	97-99	50	SQ2	1-1/4	36267†		JR, GP	36063	300/3,500		20
DeVille	00-05	33	SQ2	1-1/4	36287	0	GP	36071	300/3,500		20

† Available while supply lasts.

AA Requires temporary removal of bumper during installation.

AL Additional installation time required for vehicles equipped with load leveling compressor.

AW Will not fit Turbo models.

DU Fascia removal required.

EP Fascia trimming may be required.

GP Hitch cross-tube concealed behind bumper.

HM Hitch cross-tube is visible beneath bumper.

JR Exhaust must be temporarily lowered for installation.

KH Minor heat shield modification may be required.

QW Will not fit vehicles with dual exhaust.

TA Trunk access required for hitch installation.

TN Hitches produced before 07/09/12 are rated at 500/5000 WC & 500/5000 WD.

X Minor fascia trimming required.

T-ONE					TOW HARNESS					4-FLAT WIRING				REQ. 4 FLAT WIRING		7-WAY HARDWIRE	BRAKE CONTROL HARNESS	IN			
PC	T-ONE	FN	IN	AMP	CP	PC	TOW HARN	FN	IN	AMP	CP	TYPE	ELEC	POS	CHOICE 1				CHOICE 2	6-WAY ADAPTER	7-WAY ADAPTER
BUICK (Continued)																					
						E12	8551511 85219 22111	RD RD BN	5 25			7-Way 7-Way 7-Way	A	SUV6						3026-P	5
E10	118270	BN	20	7.5		E16	118271	BN	20			7-Way	B,E	SUV1.2	119191	119148	20320	20321	20224	3026-P	5
E4	118761	BN,CH	15	7.5	X	E9	118287	BN	15			7-Way	A	SUV5							
E16	118588	CH	45	4.2,7.5	X								B,E	SUV3.4	119191	119148	20320	20321			
E16	118745	CH	45	4.2,7.5	X								B,E	SUV3.4							
E5	118725	BN	15	7.5	X								A	SUV5	119148	20252					
E5	118725	BN	15	7.5	X								A	SUV5	119148	20252					
E7	118479		10	7.5									A	PC3.4	119148	20252					
E18	118497	CH	45	2.1,5.6	X								B,E	PC1.2	119191	119148					
E18	118497	C,H	45	2.1,5.6	X								B,E	PC3.4	119191	119148					
E18	118497	CH	45	2.1,5.6	X								B,E	PC1.2	119191	119148					
E18	118497	CH	45	2.1,5.6	X								B,E	PC1.2	119191	119148					
E18	118497	CH	45	2.1,5.6	X								B,E	PC1.2	119191	119148					
E15	118733	CH	45	5.7.5	X								A,E	PC3.4	119191	119148					
													A	PC3.4	119148	20252					
													A,E	PC3.4	119191	119148					
E5	118419		10	7.5									A	PC3.4	119148	20252					
E5	118419		10	7.5									A	PC3.4	119148	20252					
E5	118419		10	7.5									A	PC3.4	119148	20252					
													B	PC3.4	119130	119178					
						E8	118384 74682 8551511 85219	BN,RD RD RD RD	5 10 5	7.5		4-Flat Both 7-Way 7-Way	H	SUV6	119148	20252					
													A	PC3.4	119148	20252					
E18	118504	CH	45	2.1,5.6	X								A,E	PC3.4	119191	119148					
E18	118504	CH	45	2.1,5.6	X								A,E	PC1.2	119191	119148					
E18	118639	CH	45	2.1,5.6	X								B,E	PC3.4	119191	119148					
E16	118783	CH,BN	45	5.7.5	X								A,E	PC3.4							
E16	118783	CH,BN	45	5.7.5	X								A,E	PC3.4							
E10	118383	BN	20	7.5									A	SUV1.2	119148	20252	20320	20321	20224		
E10	118396	BN	15	7.5									A	SUV1.2	119148	20252	20320	20321	20224		
E17	118564	CH	45	2.1,5.6	X								B,E	PC3.4	119191	119148					
CADILLAC																					
E15	118580	CH	25	2.1,5.6	X								B,E	PC3.4	119191	119148					
E15	118440	CH	45	2.1,4.2	X								B,E	PC3.4	119191	119148					
E15	118466	CH	15	2.1,5.6	X								A,E	PC3.4	119191	119148					
E15	118645	CH	45	2.1,5.6	X								A,E	PC3.4	119191	119148					
E15	118645	CH	45	2.1,5.6	X								A,E	PC3.4	119191	119148					
E15	118440	CH	45	2.1,4.2	X								B,E	PC3.4	119191	119148					
													A,E	PC3.4	119191	119148					
													E	PC3.4	119191	119148					
													E	PC3.4	119191	119148					

A 2 wire system.
B 3 wire system. Converter required.
BN Exterior mounted plug on some or all models. May require an aftermarket electrical mounting box or bracket. (Sold separately)
C 2 or 3 wire system determine at installation.

CH T-One is equipped with circuit protected ModuLite® module.
E ModuLite® required.
H 3 wire system with OEM standard 2 wire harness.
RD For vehicles equipped with factory tow package may require additional components or may be used as a replacement harness.

RT2 Round Tube Class II 1-1/4"
RT3 Round Tube Class III 2"
SQ1 Square Tube Class I
SQ2 Square Tube Class II
SQ3 Square Tube Class III

RECEIVER HITCH APPLICATION GUIDE

MODEL / STYLE	YEAR	TRAILER HITCHES									
		PC	REC TYPE	REC SIZE	PART NO.	NO DRILL	FOOTNOTES	OPTIONAL DRAWBAR	WC (LBS.)	WD (LBS.)	IN
CADILLAC (Continued)											
DTS	06-11	33	SQ2	1-1/4	36287	0	GP	36071	300/3,500		20
Escalade	99-00	35	SQ3	2	75037		HM		500/5,000	750/7,500	30
		41	SQ4	2	41511		HM		600/6,000	1,000/10,000	30
Escalade	02	29	RT4	2	75725	0	CN, HM		900/6,000	1,000/10,000	15
Escalade w/Factory 7-Way	02-11										
Escalade	03-06	32	SQ4	2	75172	0	CN		600/6,000	750/7,500	30
Escalade	07-14										
Escalade	15-16										
Escalade	17-18										
Escalade ESV	03-06	32	SQ4	2	75172	0	CN		600/6,000	750/7,500	30
Escalade ESV w/Factory 7-Way	03-11										
Escalade ESV w/Factory 7-Way	07-11										
Escalade EXT	02	29	RT4	2	75725	0	CN, HM		900/6,000	1,000/10,000	15
Escalade EXT w/Factory 7-Way	02-11										
Escalade EXT	03-06	32	SQ4	2	75172	0	CN		600/6,000	750/7,500	30
Seville	98-04	36	SQ2	1-1/4	36243	0	EP, GP, JR	36051	300/3,500		35
SRX Except w/Sport Package Fascia	04-09	58	RT3	2	75174	0	JR, KH		350/3,500	500/5,000	60
SRX	10-16	28	RT3	2	75682	0			400/4,000	500/5,000	15
STS	05-11	33	SQ1	1-1/4	24767		JR, TA, HM	3594	200/2,000		45
XT4	19										
		22	SQ3	2	76266	0	GP, JR, DU		675/4,500		80
XT5 Except Platinum	17-19	23	SQ3	2	76022	0	GP		675/4,500	675/4,500	20
XT6	20	24	SQ3	2	76023	0	GP, JR, AA, DU, SV, TA		675/4,500	675/4,500	
XTS	13-19	42	SQ2	1-1/4	36538		HM	36061	300/3,500		35
CHEVROLET											
Astro Extended Body	90-05	33	SQ2	1-1/4	36197	0	CS, HM	36051	300/3,500		30
		34	SQ2	1-1/4	36198	0	CS, GP	36053	300/3,500		30
		33	SQ3	2	75122	0	CS, GP		300/3,500	600/6,000	30
		50	SQ3	2	37136		AF		500/5,000	600/6,000	65
Avalanche 1500	02-06	29	RT4	2	75725	0	CN, HM		900/6,000	1,000/10,000	15
Avalanche 1500 w/Factory 7-Way	02-11										
Avalanche 1500 w/Factory 7-Way	07-11										
Avalanche 2500	02-06	29	RT4	2	75725	0	CN, HM		900/6,000	1,000/10,000	15
Avalanche 2500 w/Factory 7-Way	02-11										
Avalanche 2500 w/Factory 7-Way	07-11										
Aveo 4 Dr. Sedan	04-05										
Aveo 5 Dr. Hatchback	04-11	20	SQ1	1-1/4	24741		GP	3593	200/2,000		30
Aveo 4 Dr. Sedan	06	23	SQ1	1-1/4	24810	0	HM, TA	3593	200/2,000		20
Aveo 4 Dr. Sedan	07-11	23	SQ1	1-1/4	24810	0	HM, TA	3593	200/2,000		20
Blazer Downsize	95-98	32	SQ2	1-1/4	36244	0	FP, GP, KK	36051	300/3,500		15
		21	RT3	2	75079	0	FP, KK, SD		400/4,000	600/6,000	15
Blazer Downsize	99-01	32	SQ2	1-1/4	36244	0	FP, GP, KK	36051	300/3,500		15
		21	RT3	2	75079	0	FP, KK, SD		400/4,000	600/6,000	15

AA Requires temporary removal of bumper during installation.

AF Hitch is ONLY rated for Weight Carrying at 3500 lbs. GTW / 350 lbs. TW and DO NOT use Weight Distribution Spring Bars for this Specific Vehicle. Except for long bed pickups.

CN Requires OEM factory bumper for hitch installation.

CS Will fit with full-size spare tire stowed under vehicle.

DU Fascia removal required.

EP Fascia trimming may be required.

FP Spare tire repositioning and/or modification of spare tire carrier may be required.

GP Hitch cross-tube concealed behind bumper.

HM Hitch cross-tube is visible beneath bumper.

JR Exhaust must be temporarily lowered for installation.

KH Minor heat shield modification may be required.

KK When installing on a vehicle originally equipped with an OEM hitch. OEM bumper brackets must be purchased and installed prior to new hitch installation.

SD Hitches produced before 07/21/06 are rated at 350/3500 WC.

SV Trimming or removal of under body appearance panel may be required.

TA Trunk access required for hitch installation.

T-ONE						TOW HARNESS					4-FLAT WIRING				REQ. 4 FLAT WIRING		7-WAY HARDWIRE	BRAKE CONTROL HARNESS	IN				
PC	T-ONE	FN	IN	AMP	CP	PC	TOW HARN	FN	IN	AMP	CP	TYPE	ELEC	POS	CHOICE 1	CHOICE 2				6-WAY ADAPTER	7-WAY ADAPTER		
CADILLAC (Continued)																							
E16	118535	CH	45	2.1,5.6	X								B,E	PC3,4	119191	119148							
E3	118319	BN	5	7.5									A	SUV7	119148	20252	20320	20321	20224				
						E8	118384	BN,RD	5	7.5		4-Flat	A	SUV6	119148	20252	20320	20321	20224	3025-P	5		
							74682	RD	10			Both	H	SUV6	119148	20252							
							8551511	RD				7-Way											
							85219	RD	5			7-Way											
						E8	118384	BN,RD	5	7.5		4-Flat	A	SUV6	119148	20252	20320	20321	20224	3015-P	5		
						E8	118384	BN,RD	5	7.5		4-Flat	H	SUV6	119148	20252							
						E8	118384	BN,RD	5	7.5		4-Flat	H	SUV6	119148	20252					3016-P	5	
																					3016-P	5	
						E8	118384	BN,RD	5	7.5		4-Flat	A	SUV6	119148	20252	20320	20321	20224			3015-P	5
							74682	RD	10			Both	H	SUV6	119148	20252							
							8551511	RD				7-Way											
							85219	RD	5			7-Way											
						E8	118384	BN,RD	5	7.5		4-Flat	H	SUV6	119148	20252							
						E8	118384	BN,RD	5	7.5		4-Flat	A	SUV6	119148	20252	20320	20321	20224			3025-P	5
							74682	RD	10			Both	H	SUV6	119148	20252							
							8551511	RD				7-Way											
							85219	RD	5			7-Way											
						E8	118384	BN,RD	5	7.5		4-Flat	A	SUV6	119148	20252	20320	20321	20224			3015-P	5
													B,E	PC3,4	119191	119148							
													E	SUV3,4	119191	119148	20320	20321	20224				
						E3	118259	BN	5	7.5		4-Flat	E	SUV3,4	119191	119148	20320	20321	20224				
													E	PC3,4	119191	119148							
E3	118795	BN	15	5.7,5	X								A	SUV6									
E3	118720	BN	10			E9	118276	BN	10			7-Way	A	SUV6	119148	20252							
													A,E	PC3,4	119191	119148							
CHEVROLET																							
													A	SUV4	119148	20252	20320	20321	20224				
						E8	118384	BN,RD	5	7.5		4-Flat	A	SUV6	119148	20252	20320	20321	20224			3015-P	5
							74682	RD	10			Both	H	SUV6	119148	20252							
							8551511	RD				7-Way											
							85219	RD	5			7-Way											
						E8	118384	BN,RD	5	7.5		4-Flat	H	SUV6	119148	20252							
						E8	118384	BN,RD	5	7.5		4-Flat	A	SUV6	119148	20252	20320	20321	20224			3015-P	5
							74682	RD	10			Both	H	SUV6	119148	20252							
							8551511	RD				7-Way											
							85219	RD	5			7-Way											
						E8	118384	BN,RD	5	7.5		4-Flat	H	SUV6	119148	20252							
E13	118485	CG	15	2.1,7.5	X								B	PC3,4	119130	119178							
E13	118485	CG	15	2.1,7.5	X								B	PC3,4	119130	119178							
E13	118485	CG	15	2.1,7.5	X								B	PC3,4	119130	119178							
E12	118514		25	2.1,5	X								B	PC3,4	119130	119178							
													A	SUV7	119148	20252	20320	20321	20224				
						E8	118384	BN,RD	5	7.5		4-Flat	A	SUV7	119148	20252	20320	20321	20224				

A 2 wire system.
B 3 wire system. Converter required.
BN Exterior mounted plug on some or all models. May require an aftermarket electrical mounting box or bracket. (Sold separately)
CG T-One incorporates circuit protected taillight converter.
CH T-One is equipped with circuit protected ModuLite® module.
E ModuLite® required.
H 3 wire system with OEM standard 2 wire harness.
RD For vehicles equipped with factory tow package may require additional components or may be used as a replacement harness.

RT3 Round Tube Class III 2"
RT4 Round Tube Class IV 2"
SQ1 Square Tube Class I
SQ2 Square Tube Class II
SQ3 Square Tube Class III
SQ4 Square Tube Class IV

RECEIVER HITCH APPLICATION GUIDE

MODEL / STYLE	YEAR	TRAILER HITCHES									
		PC	REC TYPE	REC SIZE	PART NO.	NO DRILL	FOOTNOTES	OPTIONAL DRAWBAR	WC (LBS.)	WD (LBS.)	IN
CHEVROLET (Continued)											
Blazer Downsize, w/Factory 7-Way	99-01										
Blazer Downsize	02-05	32	SQ2	1-1/4	36244	0	FP,GP,KK	36051	300/3,500		15
		21	RT3	2	75079	0	FP,KK,SD		400/4,000	600/6,000	15
Blazer	19	24	SQ3	2	76023	0	GP,JP,AA,DU,SV,TA		675/4,500	675/4,500	90
Blazer Trailblazer	99-01	32	SQ2	1-1/4	36244	0	FP,GP,KK	36051	300/3,500		15
		21	RT3	2	75079	0	FP,KK,SD		400/4,000	600/6,000	15
Blazer Trailblazer w/Factory 7-Way	99-01										
Bolt EV	17-19	20	SQ1	1-1/4	24956	0	GP,X	3593	200/2,000		20
C1500	88-99	49	RT3	2	37133				500/5,000	750/7,500	40
		35	SQ3	2	75033	0	HM,J		500/5,000	800/8,000	20
		25	SQ3	2	75099	0	GP		500/5,000	800/8,000	20
		37	SQ4	2	40050		HC		600/6,000	1,000/10,000	40
		44	SQ4	2	41524	0	GP		600/6,000	1,000/10,000	20
		38	SQ4	2	41525†	0	HM,J		600/6,000	1,000/10,000	20
		54	RT4	2	37130				700/7,000	1,200/12,000	40
45	SQ5	2	41901		@,DB,GP,SN		1,000/10,000	1,300/13,000	30		
C1500 w/10" Deep Drop Bumper	88-99	49	SQ4	2	41528	0	FS,J		600/6,000	1,000/10,000	20
C1500 w/Aftermarket Roll Pan	88-99	37	SQ3	2	41522		CO,HK		500/5,000	550/5,500	40
C2500 Regular & Extended Cabs	88-99	49	RT3	2	37133				500/5,000	750/7,500	40
		35	SQ3	2	75033	0	HM,J		500/5,000	800/8,000	20
		25	SQ3	2	75099	0	GP		500/5,000	800/8,000	20
		37	SQ4	2	40050		HC		600/6,000	1,000/10,000	40
		44	SQ4	2	41524	0	GP		600/6,000	1,000/10,000	20
		38	SQ4	2	41525†	0	HM,J		600/6,000	1,000/10,000	20
		54	RT4	2	37130				700/7,000	1,200/12,000	40
59	SQ5	2-1/2	45506		#		1,200/12,000	1,700/14,000	45		
C2500 Regular & Extended Cabs	88-00	45	SQ5	2	41901		@,DB,GP,SN		1,000/10,000	1,300/13,000	30
C2500 Regular & Extended Cabs, w/10" Deep Drop Bumper	88-99	49	SQ4	2	41528	0	FS,J		600/6,000	1,000/10,000	20
C2500 w/Aftermarket Roll Pan	88-99	37	SQ3	2	41522		CO,HK		500/5,000	550/5,500	40
C2500 Crew Cab	92-00	49	RT3	2	37133	0			500/5,000	750/7,500	40
		35	SQ3	2	75033	0	HM,J		500/5,000	800/8,000	20
		25	SQ3	2	75099	0	GP		500/5,000	800/8,000	20
		37	SQ4	2	40050		FS		600/6,000	1,000/10,000	40
		44	SQ4	2	41524	0	GP		600/6,000	1,000/10,000	20
		38	SQ4	2	41525†	0	HM,J		600/6,000	1,000/10,000	20
		54	RT4	2	37130				700/7,000	1,200/12,000	40
45	SQ5	2	41901		@,DB,GP,SN		1,000/10,000	1,300/13,000	30		
59	SQ5	2-1/2	45506		#		1,200/12,000	1,700/14,000	45		
C2500 Crew Cab w/10" Deep Drop Bumper	92-00	49	SQ4	2	41528	0	FS,J		600/6,000	1,000/10,000	20
C3500 Regular & Extended Cabs	88-00	49	RT3	2	37133				500/5,000	750/7,500	40
		35	SQ3	2	75033	0	HM,J		500/5,000	800/8,000	20
		25	SQ3	2	75099	0	GP		500/5,000	800/8,000	20
		37	SQ4	2	40050		HC		600/6,000	1,000/10,000	40
		44	SQ4	2	41524	0	GP		600/6,000	1,000/10,000	20
		38	SQ4	2	41525†	0	HM,J		600/6,000	1,000/10,000	20
		54	RT4	2	37130				700/7,000	1,200/12,000	40
45	SQ5	2	41901		@,DB,GP,SN		1,000/10,000	1,300/13,000	30		
59	SQ5	2-1/2	45506		#		1,200/12,000	1,700/14,000	45		
C3500 Regular & Extended Cabs, w/10" Deep Drop Bumper	88-00	49	SQ4	2	41528	0	FS,J		600/6,000	1,000/10,000	20

- # Titan hitches require use of a 2-1/2" shank Titan ball mount.
- @ Ultra Frame ball mount must be used to achieve maximum weight carrying rating.
- AA Requires temporary removal of bumper during installation.
- CO Will not fit 8 ft. 2500/3500 Series with heavy-duty suspension or four door Crew Cab.
- DB Will not fit 6 ft. bed pickups.
- DU Fascia removal required.
- FP Spare tire repositioning and/or modification of spare tire carrier may be required.
- FS Includes 2 & 4 WD models with heavy duty suspension.
- GP Hitch cross-tube concealed behind bumper.
- HC Will not fit with mini or full size tire stowed under vehicle.
- HK Under vehicle spare tire stowage may be retained with installation of an aftermarket spare tire repositioner. Cutting of rollpan in license plate area required for receiver tube access. Does not fit with bumper.
- HM Hitch cross-tube is visible beneath bumper.
- J Under vehicle spare tire stowage is retained.
- JR Exhaust must be temporarily lowered for installation.
- KK When installing on a vehicle originally equipped with an OEM hitch. OEM bumper brackets must be purchased and installed prior to new hitch installation.
- SD Hitches produced before 07/21/06 are rated at 350/3500 WC.
- SN Hitches produced before 04/28/08 are rated at 1000/10000 WC & 1200/12000 WD.
- SV Trimming or removal of under body appearance panel may be required.
- TA Trunk access required for hitch installation.

T-ONE					TOW HARNESS					4-FLAT WIRING				REQ. 4 FLAT WIRING		7-WAY HARDWARE	BRAKE CONTROL HARNESS	IN			
PC	T-ONE	FN	IN	AMP	CP	PC	TOW HARN	FN	IN	AMP	CP	TYPE	ELEC	POS	CHOICE 1				CHOICE 2	6-WAY ADAPTER	7-WAY ADAPTER
CHEVROLET (Continued)																					
							74682 85219 8551511	RD RD RD	10 5			Both 7-Way 7-Way	A	SUV7	119148	20252					
													A	SUV7	119148	20252	20320	20321	20224		
E3	118720	BN	10			E9	118276	BN	10			7-Way	A	SUV6	119148	20252				3026-P	5
						E8	118384	BN,RD	5	7.5		4-Flat	A	SUV7	119148	20252	20320	20321	20224		
							74682 85219 8551511	RD RD RD	10 5			Both 7-Way 7-Way	A	SUV7	119148	20252					
													B,E		119191	119148					
E3	118315	BN	5	7.5									A	PU3	119148	20252	20320	20321	20224		
E3	118315	BN	5	7.5									A	PU3	119148	20252	20320	20321	20224		
E3	118315	BN	5	7.5									A	PU3	119148	20252	20320	20321	20224		
E3	118315	BN	5	7.5									A	PU3	119148	20252	20320	20321	20224		
E3	118315	BN	5	7.5									A	PU3	119148	20252	20320	20321	20224		
E3	118315	BN	5	7.5									A	PU3	119148	20252	20320	20321	20224		
E3	118315	BN	5	7.5									A	PU3	119148	20252	20320	20321	20224		
E3	118315	BN	5	7.5									A	PU3	119148	20252	20320	20321	20224		
E3	118315	BN	5	7.5									A	PU3	119148	20252	20320	20321	20224		

A 2 wire system.
B 3 wire system. Converter required.
BN Exterior mounted plug on some or all models. May require an aftermarket electrical mounting box or bracket. (Sold separately)

E ModuLite® required.
RD For vehicles equipped with factory tow package may require additional components or may be used as a replacement harness.

RT3 Round Tube Class III 2"
RT4 Round Tube Class IV 2"
SQ1 Square Tube Class I
SQ2 Square Tube Class II
SQ3 Square Tube Class III
SQ4 Square Tube Class IV
SQ5 Square Tube Class V

CHEVROLET

RECEIVER HITCHES

RECEIVER HITCH APPLICATION GUIDE

MODEL / STYLE	YEAR	TRAILER HITCHES									
		PC	REC TYPE	REC SIZE	PART NO.	NO DRILL	FOOTNOTES	OPTIONAL DRAWBAR	WC (LBS.)	WD (LBS.)	IN
CHEVROLET (Continued)											
C3500 w/Aftermarket Roll Pan	88-00	37	SQ3	2	41522		CO,HK		500/5,000	550/5,500	40
C3500 Crew Cab	92-00	49	RT3	2	37133	0			500/5,000	750/7,500	40
		35	SQ3	2	75033	0	HM,J		500/5,000	800/8,000	20
		25	SQ3	2	75099	0	GP		500/5,000	800/8,000	20
		44	SQ4	2	41524	0	GP		600/6,000	1,000/10,000	20
		38	SQ4	2	41525†	0	HM,J		600/6,000	1,000/10,000	20
		54	RT4	2	37130				700/7,000	1,200/12,000	40
		45	SQ5	2	41901		@,DB,GP,SN		1,000/10,000	1,300/13,000	30
		59	SQ5	2-1/2	45506		#		1,200/12,000	1,700/14,000	45
C3500 Crew Cab w/10" Deep Drop Bumper	92-00	49	SQ4	2	41528	0	FS,J		600/6,000	1,000/10,000	20
Camaro Except Convertible & w/Dealer Installed Ground Effects	10-11	30	SQ1	1-1/4	24850	0	GP	3594	200/2,000		15
Camaro Except Convertible & w/Dealer Installed Ground Effects	12-15	30	SQ1	1-1/4	24850	0	GP	3594	200/2,000		15
Camaro	16-19	23	SQ1	1-1/4	24938	0	GP	3593	200/2,000		50
Captiva Sport	12-15	30	SQ3	2	75556	0	GP		400/4,000	400/4,000	15
Cavalier Except Z-24	95-99	31	SQ1	1-1/4	24733		GP,JR	3592	200/2,000		40
Cavalier	00-01	31	SQ1	1-1/4	24733		GP,JR	3592	200/2,000		40
Cavalier Except Z-24	02	31	SQ1	1-1/4	24733		GP,JR	3592	200/2,000		40
Cavalier Except LS Sport	03-05	31	SQ1	1-1/4	24733		GP,JR	3592	200/2,000		40
Cavalier LS Sport	03-05	36	SQ1	1-1/4	24613†		JR,KH,GP	3592	200/2,000		40
Cavalier Z-24	95-99	36	SQ1	1-1/4	24613†		JR,KH,GP	3592	200/2,000		40
Cavalier Z-24	02	36	SQ1	1-1/4	24613†		JR,KH,GP	3592	200/2,000		40
Cavalier Z-24 (Canada Only)	03-05	36	SQ1	1-1/4	24613†		JR,KH,GP	3592	200/2,000		40
City Express	15-17	31	RT3	2	75898	0	HM,JR,X		525/3,500		30
Cobalt 2 Dr., Except SS	05-10	20	SQ1	1-1/4	24745		JR,HM	3593	200/2,000		40
Cobalt 4 Dr., Except SS	05-10	20	SQ1	1-1/4	24745		JR,HM	3593	200/2,000		40
Cobalt Sport 2 Dr.	08	30	SQ1	1-1/4	24756		HM,JR	3594	200/2,000		25
Cobalt Sport 4 Dr.	08	30	SQ1	1-1/4	24756		HM,JR	3594	200/2,000		25
Cobalt SS 2 Dr.	05-10	30	SQ1	1-1/4	24756		HM,JR	3594	200/2,000		25
Cobalt SS 4 Dr.	05-10	30	SQ1	1-1/4	24756		HM,JR	3594	200/2,000		25
Colorado	04-12	23	SQ4	2	75607	0	CP,GP		600/6,000	750/7,500	25
Colorado w/Factory 7-Way	04-12										
Colorado	15-19	34	RT4	2	75948	0	HM,AA,V,SO,TZ		800/6,000	800/8,000	35
		30	SQ4	2	76004	0	HM,AA,V,SO,TZ		800/8,000	1,000/10,000	35
Cruze	11-15	18	SQ1	1-1/4	24882	0	GP	3593	200/2,000		15
Cruze (New Body Style)	16-19	18	SQ1	1-1/4	24943	0	GP,X,DU,TA	3593	200/2,000		80
Cruze Limited Only (Old Body Style)	16	18	SQ1	1-1/4	24882	0	GP	3593	200/2,000		15
Cruze Hatchback	17-19	18	SQ1	1-1/4	24951	0	GP,X,DU	3594	200/2,000		60
Equinox	05-06	18	SQ2	1-1/4	36408	0	HM	36051	300/3,500		25
		14	RT3	2	76028	0	HM		675/4,500	675/4,500	30
Equinox	07-09	18	SQ2	1-1/4	36408	0	HM	36051	300/3,500		25
		14	RT3	2	76028	0	HM		675/4,500	675/4,500	30
Equinox	10-17	18	SQ2	1-1/4	36408	0	HM	36051	300/3,500		25
		14	RT3	2	76028	0	HM		675/4,500	675/4,500	30
Equinox Diesel	18-20	28	SQ3	2	76217	0	AI,DU,JR,TZ,X		675/4,500	675/4,500	70
Equinox Except Premier or Models w/1.6L Diesel	18-20	22	SQ2	1-1/4	36642	0	JR,GP	36051	350/3,500		35
		23	SQ3	2	76419	0	JR		675/4,500	675/4,500	35
Equinox Premier, Except Models w/1.6L Diesel	18-20	22	SQ2	1-1/4	36642	0	JR,GP	36051	350/3,500		35
		23	SQ3	2	76419	0	JR		675/4,500	675/4,500	35
Equinox w/ Tow Prep Package	18-20										

Titan hitches require use of a 2-1/2" shank Titan ball mount.

@ Ultra Frame ball mount must be used to achieve maximum weight carrying rating.

AA Requires temporary removal of bumper during installation.

AI Additional installation time may be required.

CO Will not fit 8 ft. 2500/3500 Series with heavy-duty suspension or four door Crew Cab.

CP Fits all models without factory installed receiver.

DB Will not fit 6 ft. bed pickups.

DU Fascia removal required.

FS Includes 2 & 4 WD models with heavy duty suspension.

GP Hitch cross-tube concealed behind bumper.

HM Hitch cross-tube is visible beneath bumper.

J Under vehicle spare tire stowage is retained.

JR Exhaust must be temporarily lowered for installation.

KH Minor heat shield modification may be required.

SN Hitches produced before 04/28/08 are rated at 1000/10000 WC & 1200/12000 WD.

SO With this hitch installed the step bumper is no longer able to be used as a towing point.

TA Trunk access required for hitch installation.

TZ Requires replacement of the impact structure with hitch.

V For vehicles with factory installed step bumpers only.

X Minor fascia trimming required.

T-ONE					TOW HARNESS					4-FLAT WIRING				REQ. 4 FLAT WIRING		7-WAY HARDWIRE	BRAKE CONTROL HARNESS	IN	
PC	T-ONE	FN	IN	AMP	CP	PC	TOW HARN	FN	IN	AMP	CP	TYPE	ELEC	POS	CHOICE 1				CHOICE 2
CHEVROLET (Continued)																			
E3	118315	BN	5	7.5									A	PU3	119148	20252	20320	20321	20224
E3	118315	BN	5	7.5									A	PU3	119148	20252	20320	20321	20224
E3	118315	BN	5	7.5									A	PU3	119148	20252	20320	20321	20224
E17	118486	CH	15	2.1,5.6	X								A,E	PC1,2	119191	119148			
E16	118556	CH	25	2.1,5.6	X								A,E	PC1,2	119191	119148			
E17	118690	CH	45	4.2,7.5	X								A,E	PC1,2	119191	119148			
E19	118443	CH	45	2.1,4.2	X								B,E	SUV3,4	119191	119148	20320	20321	20224
													A	PC3,4	119148	20252			
													A	PC3,4	119148	20252			
													A	PC3,4	119148	20252			
													A	PC3,4	119148	20252			
													A	PC3,4	119148	20252			
													A	PC3,4	119148	20252			
													A	PC3,4	119148	20252			
													A	PC3,4	119148	20252			
E17	118597	CH	45	4.2,7.5	X								B,E	SUV3,4	119191	119148	20320	20321	
E5	118407	BN	15	7.5									A	PC1,2	119148	20252			
E8	118398	BN	10	7.5									A	PC1,2	119148	20252			
E5	118407	BN	15	7.5									A	PC1,2	119148	20252			
E8	118398	BN	10	7.5									A	PC1,2	119148	20252			
E5	118407	BN	15	7.5									A	PC1,2	119148	20252			
E8	118398	BN	10	7.5									A	PC1,2	119148	20252			
E10	118301	BN,CG	10	2.1,5	X	E8	118384	BN,RD	5	7.5		4-Flat	B	PU3	119130	119178	20320	20321	20224
							74682	RD	10			Both	H	PU3	119148	20252			
							8551511	RD	5			7-Way							
							85219	RD	5			7-Way							
													A	PU3	119148	20252	20320	20321	20224
E19	118508	CH	45	2.1,5.6	X								B,E	PC3,4	119191	119148			
E14	118696	CH	45		X								A,E	PC3,4	119191	119148			
E19	118508	CH	45	2.1,5.6	X								B,E	PC3,4	119191	119148			
E23	118734	CH	45	5.7,5	X														
E8	118391	CG	10	2.1,5	X								B	SUV3	119130	119178	20320	20321	20224
E7	118432	CE	10	7.5									B	SUV1,2	119130	119178	20320	20321	20224
E16	118494	CH	45	2.1,5.6	X	E1	118264	RD	15	7.5		4-Flat	N	SUV1,2		119251	20320	20321	
E17	118750	CH,BN	45	4.2,7.5	X								BTT	SUV1,2					
E17	118750	CH,BN	45	4.2,7.5	X								BTT	SUV1,2					
E15	118759	CH,BN	45	5.7,5	X								A,E	SUV1,2					
						E6	118285	BN,CH	15	7.5		4-Flat	A	SUV5					

- A** 2 wire system.
- B** 3 wire system. Converter required.
- BN** Exterior mounted plug on some or all models. May require an aftermarket electrical mounting box or bracket. (Sold separately)
- BTT** Shared Brake/Tail/Turn multiplexed wiring system. ModuLite® HD Plus or Ultra required.
- CE** T-One includes fuse(s) & relay(s). Converter not required. Standard 2 wire system at factory tow plug.
- CG** T-One incorporates circuit protected taillight converter.
- CH** T-One is equipped with circuit protected ModuLite® module.
- E** ModuLite® required.
- H** 3 wire system with OEM standard 2 wire harness.
- N** DO NOT cut or splice vehicle wiring. Only use approved T-One or see auto dealer for trailer tow wiring kit.
- RD** For vehicles equipped with factory tow package may require additional components or may be used as a replacement harness.

- RT3** Round Tube Class III 2"
- RT4** Round Tube Class IV 2"
- SQ1** Square Tube Class I
- SQ2** Square Tube Class II
- SQ3** Square Tube Class III
- SQ4** Square Tube Class IV
- SQ5** Square Tube Class V

CHEVROLET

RECEIVER HITCHES

RECEIVER HITCH APPLICATION GUIDE

MODEL / STYLE	YEAR	TRAILER HITCHES									
		PC	REC TYPE	REC SIZE	PART NO.	NO DRILL	FOOTNOTES	OPTIONAL DRAWBAR	WC (LBS.)	WD (LBS.)	IN
CHEVROLET (Continued)											
Express 1500	96-99	31	SQ2	1-1/4	36206	0	HM	36053	300/3,500		15
		50	SQ3	2	37136		HM		500/5,000	600/6,000	30
		20	SQ3	2	75189	0	HM		500/5,000	750/7,500	15
		33	SQ4	2	41521	0	HM		600/6,000	1,000/10,000	15
		42	SQ5	2	41946		@,HM		1,500/10,000	1,300/13,000	35
Express 1500	00-02	31	SQ2	1-1/4	36206	0	HM	36053	300/3,500		15
		50	SQ3	2	37136		HM		500/5,000	600/6,000	30
		20	SQ3	2	75189	0	HM		500/5,000	750/7,500	15
		33	SQ4	2	41521	0	HM		600/6,000	1,000/10,000	15
		42	SQ5	2	41946		@,HM		1,500/10,000	1,300/13,000	35
Express 1500	03	31	SQ2	1-1/4	36206	0	HM	36053	300/3,500		15
		50	SQ3	2	37136		HM		500/5,000	600/6,000	30
		20	SQ3	2	75189	0	HM		500/5,000	750/7,500	15
		33	SQ4	2	41521	0	HM		600/6,000	1,000/10,000	15
		42	SQ5	2	41946		@,HM		1,500/10,000	1,300/13,000	35
Express 1500	04-14	31	SQ2	1-1/4	36206	0	HM	36053	300/3,500		15
		50	SQ3	2	37136		HM		500/5,000	600/6,000	30
		20	SQ3	2	75189	0	HM		500/5,000	750/7,500	15
		33	SQ4	2	41521	0	HM		600/6,000	1,000/10,000	15
		42	SQ5	2	41946		@,HM		1,500/10,000	1,300/13,000	35
Express 2500	96-99	31	SQ2	1-1/4	36206	0	HM	36053	300/3,500		15
		50	SQ3	2	37136		HM		500/5,000	600/6,000	30
		20	SQ3	2	75189	0	HM		500/5,000	750/7,500	15
		33	SQ4	2	41521	0	HM		600/6,000	1,000/10,000	15
		42	SQ5	2	41946		@,HM		1,500/10,000	1,300/13,000	35
		52	SQ5	2-1/2	45507	0	#,HM		1,200/12,000	1,700/14,000	45
Express 2500	00-02	31	SQ2	1-1/4	36206	0	HM	36053	300/3,500		15
		50	SQ3	2	37136		HM		500/5,000	600/6,000	30
		20	SQ3	2	75189	0	HM		500/5,000	750/7,500	15
		33	SQ4	2	41521	0	HM		600/6,000	1,000/10,000	15
		42	SQ5	2	41946		@,HM		1,500/10,000	1,300/13,000	35
		52	SQ5	2-1/2	45507	0	#,HM		1,200/12,000	1,700/14,000	45
Express 2500	03	31	SQ2	1-1/4	36206	0	HM	36053	300/3,500		15
		50	SQ3	2	37136		HM		500/5,000	600/6,000	30
		20	SQ3	2	75189	0	HM		500/5,000	750/7,500	15
		33	SQ4	2	41521	0	HM		600/6,000	1,000/10,000	15
		42	SQ5	2	41946		@,HM		1,500/10,000	1,300/13,000	35
		52	SQ5	2-1/2	45507	0	#,HM		1,200/12,000	1,700/14,000	45
Express 2500	04-18	31	SQ2	1-1/4	36206	0	HM	36053	300/3,500		15
		50	SQ3	2	37136		HM		500/5,000	600/6,000	30
		20	SQ3	2	75189	0	HM		500/5,000	750/7,500	15
		33	SQ4	2	41521	0	HM		600/6,000	1,000/10,000	15
		42	SQ5	2	41946		@,HM		1,500/10,000	1,300/13,000	35
		52	SQ5	2-1/2	45507	0	#,HM		1,200/12,000	1,700/14,000	45
Express 2500	19	31	SQ2	1-1/4	36206	0	HM	36053	300/3,500		15
		50	SQ3	2	37136		HM		500/5,000	600/6,000	30
		20	SQ3	2	75189	0	HM		500/5,000	750/7,500	15
		33	SQ4	2	41521	0	HM		600/6,000	1,000/10,000	15
		42	SQ5	2	41946		@,HM		1,500/10,000	1,300/13,000	35
		52	SQ5	2-1/2	45507	0	#,HM		1,200/12,000	1,700/14,000	45

Titan hitches require use of a 2-1/2" shank Titan ball mount.

HM Hitch crosstube is visible beneath bumper.

@ Ultra Frame ball mount must be used to achieve maximum weight carrying rating.

T-ONE					TOW HARNESS							4-FLAT WIRING				REQ. 4 FLAT WIRING		7-WAY HARDWIRE	BRAKE CONTROL HARNESS	IN	
PC	T-ONE	FN	IN	AMP	CP	PC	TOW HARN	FN	IN	AMP	CP	TYPE	ELEC	POS	CHOICE 1	CHOICE 2	6-WAY ADAPTER				7-WAY ADAPTER
CHEVROLET (Continued)																					
E8	118335	HG	10	2.1,5		E1	118240	RD	5	7.5		4-Flat	B	SUV3,4	119130	119178	20320	20321	20224		
E8	118377	HG	10	2.1,5		E1	118240	RD	5	7.5		4-Flat	B	SUV3,4	119130	119178	20320	20321	20224		
E5	118392		20	7.5		E1	118240	RD	5	7.5		4-Flat	A	SUV3,4	119148	20252	20320	20321	20224		
E5	118392		20	7.5									A	SUV3,4	119148	20252	20320	20321	20224		
E8	118335	HG	10	2.1,5		E1	118240	RD	5	7.5		4-Flat	B	SUV3,4	119130	119178	20320	20321	20224		
E8	118377	HG	10	2.1,5		E1	118240	RD	5	7.5		4-Flat	B	SUV3,4	119130	119178	20320	20321	20224		
E5	118392		20	7.5		E1	118240	RD	5	7.5		4-Flat	A	SUV3,4	119148	20252	20320	20321	20224		
E5	118392		20	7.5									A	SUV3,4	119148	20252	20320	20321	20224		
													A	SUV3,4	119148	20252	20320	20321	20224		

A 2 wire system.
B 3 wire system. Converter required.

HG T-One incorporates taillight converter.
RD For vehicles equipped with factory tow package may require additional components or may be used as a replacement harness.

SQ2 Square Tube Class II
SQ3 Square Tube Class III
SQ4 Square Tube Class IV
SQ5 Square Tube Class V

RECEIVER HITCH APPLICATION GUIDE

MODEL / STYLE	YEAR	TRAILER HITCHES									
		PC	REC TYPE	REC SIZE	PART NO.	NO DRILL	FOOTNOTES	OPTIONAL DRAWBAR	WC (LBS.)	WD (LBS.)	IN
CHEVROLET (Continued)											
Express 3500	96-99	31	SQ2	1-1/4	36206	0	HM	36053	300/3,500		15
		50	SQ3	2	37136	0	HM		500/5,000	600/6,000	30
		20	SQ3	2	75189	0	HM		500/5,000	750/7,500	15
		33	SQ4	2	41521	0	HM		600/6,000	1,000/10,000	15
		42	SQ5	2	41946	0	@,HM		1,500/10,000	1,300/13,000	35
		52	SQ5	2-1/2	45507	0	#,HM		1,200/12,000	1,700/14,000	45
Express 3500	00-02	31	SQ2	1-1/4	36206	0	HM	36053	300/3,500		15
		50	SQ3	2	37136	0	HM		500/5,000	600/6,000	30
		20	SQ3	2	75189	0	HM		500/5,000	750/7,500	15
		33	SQ4	2	41521	0	HM		600/6,000	1,000/10,000	15
		42	SQ5	2	41946	0	@,HM		1,500/10,000	1,300/13,000	35
		52	SQ5	2-1/2	45507	0	#,HM		1,200/12,000	1,700/14,000	45
Express 3500	03	31	SQ2	1-1/4	36206	0	HM	36053	300/3,500		15
		50	SQ3	2	37136	0	HM		500/5,000	600/6,000	30
		20	SQ3	2	75189	0	HM		500/5,000	750/7,500	15
		33	SQ4	2	41521	0	HM		600/6,000	1,000/10,000	15
		42	SQ5	2	41946	0	@,HM		1,500/10,000	1,300/13,000	35
		52	SQ5	2-1/2	45507	0	#,HM		1,200/12,000	1,700/14,000	45
Express 3500	04-18	31	SQ2	1-1/4	36206	0	HM	36053	300/3,500		15
		50	SQ3	2	37136	0	HM		500/5,000	600/6,000	30
		20	SQ3	2	75189	0	HM		500/5,000	750/7,500	15
		33	SQ4	2	41521	0	HM		600/6,000	1,000/10,000	15
		42	SQ5	2	41946	0	@,HM		1,500/10,000	1,300/13,000	35
		52	SQ5	2-1/2	45507	0	#,HM		1,200/12,000	1,700/14,000	45
Express 3500	18										
Express 3500	19	31	SQ2	1-1/4	36206	0	HM	36053	300/3,500		15
		50	SQ3	2	37136	0	HM		500/5,000	600/6,000	30
		20	SQ3	2	75189	0	HM		500/5,000	750/7,500	15
		33	SQ4	2	41521	0	HM		600/6,000	1,000/10,000	15
		42	SQ5	2	41946	0	@,HM		1,500/10,000	1,300/13,000	35
		52	SQ5	2-1/2	45507	0	#,HM		1,200/12,000	1,700/14,000	45
HHR	06-11	30	SQ1	1-1/4	24756		HM,JR	3594	200/2,000		25
HHR SS	08-10	30	SQ1	1-1/4	24756		EP,HM,JR	3594	200/2,000		35
Impala	00-05	25	SQ1	1-1/4	24681		GP	3590	200/2,000		20
		35	SQ2	1-1/4	36407	0	GP,JR	36061	300/3,500		30
Impala	06-13	35	SQ2	1-1/4	36407	0	GP,JR	36061	300/3,500		30
Impala Eco, Except Impala Limited	14	48	SQ2	1-1/4	36543	0	HM,X	36061	300/3,500		30
Impala Except Impala Limited	14-19	42	SQ2	1-1/4	36538		HM,FE	36061	300/3,500		35
Impala LS Except Impala Limited	14	48	SQ2	1-1/4	36543	0	HM,X	36061	300/3,500		30
Impala LT Except Impala Limited	14	48	SQ2	1-1/4	36543	0	HM,X	36061	300/3,500		30
Impala LTZ Except Impala Limited	14	48	SQ2	1-1/4	36543	0	HM,X	36061	300/3,500		30
K1500	88-99	49	RT3	2	37133				500/5,000	750/7,500	40
		35	SQ3	2	75033	0	HM,J		500/5,000	800/8,000	20
		25	SQ3	2	75099	0	GP		500/5,000	800/8,000	20
		44	SQ4	2	41524	0	GP		600/6,000	1,000/10,000	20
		38	SQ4	2	415251	0	HM,J		600/6,000	1,000/10,000	20
		54	RT4	2	37130				700/7,000	1,200/12,000	40
K1500 w/10" Deep Drop Bumper	88-99	49	SQ4	2	41528	0	FS,J		600/6,000	1,000/10,000	20
		37	SQ3	2	41522				500/5,000	550/5,500	40
K1500 w/Aftermarket Roll Pan	88-99	37	SQ3	2	41522		CO,HK				

Titan hitches require use of a 2-1/2" shank Titan ball mount.
 @ Ultra Frame ball mount must be used to achieve maximum weight carrying rating.
 CO Will not fit 8 ft. 2500/3500 Series with heavy-duty suspension or four door Crew Cab.
 DB Will not fit 6 ft. bed pickups.
 EP Fascia trimming may be required.
 FE Fascia trimming may be required. Allow additional installation time.
 FS Includes 2 & 4 WD models with heavy duty suspension.

GP Hitch crosstube concealed behind bumper.
 HK Under vehicle spare tire stowage may be retained with installation of an aftermarket spare tire repositioner. Cutting of rollpan in license plate area required for receiver tube access. Does not fit with bumper.
 HM Hitch crosstube is visible beneath bumper.
 J Under vehicle spare tire stowage is retained.
 JR Exhaust must be temporarily lowered for installation.
 SN Hitches produced before 04/28/08 are rated at 1000/10000 WC & 1200/12000 WD.
 X Minor fascia trimming required.

T-ONE					TOW HARNESS							4-FLAT WIRING				REQ. 4 FLAT WIRING		7-WAY HARDWARE	BRAKE CONTROL HARNESS	IN
PC	T-ONE	FN	IN	AMP	CP	PC	TOW HARN	FN	IN	AMP	CP	TYPE	ELEC	POS	CHOICE 1	CHOICE 2	6-WAY ADAPTER			
CHEVROLET (Continued)																				
E8	118335	HG	10	2.1,5		E1	118240	RD	5	7.5		4-Flat	B	SUV3,4	119130	119178	20320	20321	20224	
E8	118377	HG	10	2.1,5		E1	118240	RD	5	7.5		4-Flat	B	SUV3,4	119130	119178	20320	20321	20224	
E5	118392		20	7.5		E1	118240	RD	5	7.5		4-Flat	A	SUV3,4	119148	20252	20320	20321	20224	
E5	118392		20	7.5									A	SUV3,4	119148	20252	20320	20321	20224	
E5	118392		20	7.5									A	SUV3,4	119148	20252	20320	20321	20224	
													A	SUV3,4	119148	20252	20320	20321	20224	
E5	118407	BN	15	7.5									A	SUV3,4	119148	20252	20320	20321		
E5	118407	BN	15	7.5									A	SUV3,4	119148	20252	20320	20321		
E5	118512		25	7.5									A	PC3,4	119148	20252				
E5	118417	BN	10	7.5									A	PC2	119148	20252				
E14	118590		45	2.1,5,6	X								A,E	PC3,4	119191	119148				
E14	118590		45	2.1,5,6	X								A,E	PC3,4	119191	119148				
E14	118590		45	2.1,5,6	X								A,E	PC3,4	119191	119148				
E14	118590		45	2.1,5,6	X								A,E	PC3,4	119191	119148				
E14	118590		45	2.1,5,6	X								A,E	PC3,4	119191	119148				
E3	118315	BN	5	7.5									A	PU3	119148	20252	20320	20321	20224	
E3	118315	BN	5	7.5									A	PU3	119148	20252	20320	20321	20224	
E3	118315	BN	5	7.5									A	PU3	119148	20252	20320	20321	20224	

A 2 wire system.
B 3 wire system. Converter required.
BN Exterior mounted plug on some or all models. May require an aftermarket electrical mounting box or bracket. (Sold separately)

E ModuLite® required.
HG T-One incorporates taillight converter.
RD For vehicles equipped with factory tow package may require additional components or may be used as a replacement harness.

RT3 Round Tube Class III 2"
RT4 Round Tube Class IV 2"
SQ1 Square Tube Class I
SQ2 Square Tube Class II
SQ3 Square Tube Class III
SQ4 Square Tube Class IV
SQ5 Square Tube Class V

CHEVROLET

RECEIVER HITCHES

RECEIVER HITCH APPLICATION GUIDE

MODEL / STYLE	YEAR	TRAILER HITCHES									
		PC	REC TYPE	REC SIZE	PART NO.	NO DRILL	FOOTNOTES	OPTIONAL DRAWBAR	WC (LBS.)	WD (LBS.)	IN
CHEVROLET (Continued)											
K2500 Regular & Extended Cabs	88-99	49	RT3	2	37133				500/5,000	750/7,500	40
		35	SQ3	2	75033	0	HM,J		500/5,000	800/8,000	20
		25	SQ3	2	75099	0	GP		500/5,000	800/8,000	20
		44	SQ4	2	41524	0	GP		600/6,000	1,000/10,000	20
		38	SQ4	2	41525†	0	HM,J		600/6,000	1,000/10,000	20
		54	RT4	2	37130				700/7,000	1,200/12,000	40
		59	SQ5	2-1/2	45506		#		1,200/12,000	1,700/14,000	45
K2500 Regular & Extended Cabs	88-00	45	SQ5	2	41901		@,DB,GP,SN		1,000/10,000	1,300/13,000	30
K2500 Regular & Extended Cabs, w/10" Deep Drop Bumper	88-99	49	SQ4	2	41528	0	FS,J		600/6,000	1,000/10,000	20
K2500 w/Aftermarket Roll Pan	88-99	37	SQ3	2	41522		CO,HK		500/5,000	550/5,500	40
K2500 Crew Cab	92-00	49	RT3	2	37133	0			500/5,000	750/7,500	40
		35	SQ3	2	75033	0	HM,J		500/5,000	800/8,000	20
		25	SQ3	2	75099	0	GP		500/5,000	800/8,000	20
		44	SQ4	2	41524	0	GP		600/6,000	1,000/10,000	20
		38	SQ4	2	41525†	0	HM,J		600/6,000	1,000/10,000	20
		54	RT4	2	37130				700/7,000	1,200/12,000	40
		45	SQ5	2	41901		@,DB,GP,SN		1,000/10,000	1,300/13,000	30
		59	SQ5	2-1/2	45506		#		1,200/12,000	1,700/14,000	45
K2500 Crew Cab w/10" Deep Drop Bumper	92-00	49	SQ4	2	41528	0	FS,J		600/6,000	1,000/10,000	20
K3500 Regular & Extended Cabs	88-00	49	RT3	2	37133				500/5,000	750/7,500	40
		35	SQ3	2	75033	0	HM,J		500/5,000	800/8,000	20
		44	SQ4	2	41524	0	GP		600/6,000	1,000/10,000	20
		38	SQ4	2	41525†	0	HM,J		600/6,000	1,000/10,000	20
		54	RT4	2	37130				700/7,000	1,200/12,000	40
		45	SQ5	2	41901		@,DB,GP,SN		1,000/10,000	1,300/13,000	30
		59	SQ5	2-1/2	45506		#		1,200/12,000	1,700/14,000	45
K3500 Regular & Extended Cabs, w/10" Deep Drop Bumper	88-00	49	SQ4	2	41528	0	FS,J		600/6,000	1,000/10,000	20
K3500 w/Aftermarket Roll Pan	88-00	37	SQ3	2	41522		CO,HK		500/5,000	550/5,500	40
K3500 Crew Cab	92-00	49	RT3	2	37133	0			500/5,000	750/7,500	40
		35	SQ3	2	75033	0	HM,J		500/5,000	800/8,000	20
		25	SQ3	2	75099	0	GP		500/5,000	800/8,000	20
		44	SQ4	2	41524	0	GP		600/6,000	1,000/10,000	20
		38	SQ4	2	41525†	0	HM,J		600/6,000	1,000/10,000	20
		54	RT4	2	37130				700/7,000	1,200/12,000	40
		45	SQ5	2	41901		@,DB,GP,SN		1,000/10,000	1,300/13,000	30
		59	SQ5	2-1/2	45506		#		1,200/12,000	1,700/14,000	45
K3500 Crew Cab w/10" Deep Drop Bumper	92-00	49	SQ4	2	41528	0	FS,J		600/6,000	1,000/10,000	20
Kodiak C4500 Cab & Chassis, w/34" Wide Frames	03-09	55	SQ5	2	41947		@		1,600/15,000	1,600/16,000	35
Kodiak C5500 Cab & Chassis, w/34" Wide Frames	03-09	55	SQ5	2	41947		@		1,600/15,000	1,600/16,000	35
Kodiak C6500 Cab & Chassis, w/34" Wide Frames	99-09	55	SQ5	2	41947		@		1,600/15,000	1,600/16,000	35
Kodiak C7500 Cab & Chassis, w/34" Wide Frames	99-09	55	SQ5	2	41947		@		1,600/15,000	1,600/16,000	35
Kodiak C8500 Cab & Chassis, w/34" Wide Frames	99-09	55	SQ5	2	41947		@		1,600/15,000	1,600/16,000	35
Lumina	95-00	23	SQ1	1-1/4	24628		AI,GP	3592	200/2,000		30
		48	SQ2	1-1/4	36193†	0	JR,GP	36061	300/3,500		60
Malibu 4 Dr.	97-05	34	SQ1	1-1/4	24656		GP	3592	200/2,000		15
		41	SQ2	1-1/4	36233		GP	36061	300/3,500		20
Malibu 4 Dr.	04-07	42	SQ2	1-1/4	36317		JR,HM	36071	300/3,500		40
Malibu Except LTZ	08-12	24	SQ2	1-1/4	36479		GP,JR,RB	36065	300/3,500		45
Malibu (Canada Only)	13	46	SQ2	1-1/4	36522†	0	HM	36061	300/3,500		20
Malibu Except LTZ & Canada Models	13	46	SQ2	1-1/4	36522†	0	HM	36061	300/3,500		20
Malibu Except LTZ & Canada Models	13-15	42	SQ2	1-1/4	36538	0	HM	36061	300/3,500		35
Malibu Except Premier (New Body Style)	16-19	23	SQ2	1-1/4	36592†	0	GP,JR,EP,TA	36071	300/3,500		80
		20	SQ2	1-1/4	36652	0	GP,JR,AA,DU,X,TA	36071	350/3,500		80

Titan hitches require use of a 2-1/2" shank Titan ball mount.

@ Ultra Frame ball mount must be used to achieve maximum weight carrying rating.

AA Requires temporary removal of bumper during installation.

AI Additional installation time may be required.

CO Will not fit 8 ft. 2500/3500 Series with heavy-duty suspension or four door Crew Cab.

DB Will not fit 6 ft. bed pickups.

DU Fascia removal required.

EP Fascia trimming may be required.

FS Includes 2 & 4 WD models with heavy duty suspension.

GP Hitch crosstube concealed behind bumper.

HK Under vehicle spare tire stowage may be retained with installation of an aftermarket spare tire repositioner. Cutting of rollpan in license plate area required for receiver tube access. Does not fit with bumper.

HM Hitch crosstube is visible beneath bumper.

J Under vehicle spare tire stowage is retained.

JR Exhaust must be temporarily lowered for installation.

RB Hitch installation can be made easier with a cutter type drill bit.

SN Hitches produced before 04/28/08 are rated at 1000/10000 WC & 1200/12000 WD.

TA Trunk access required for hitch installation.

X Minor fascia trimming required.

T-ONE					TOW HARNESS							4-FLAT WIRING				REQ. 4 FLAT WIRING		7-WAY HARDWARE	BRAKE CONTROL HARNESS	IN
PC	T-ONE	FN	IN	AMP	CP	PC	TOW HARN	FN	IN	AMP	CP	TYPE	ELEC	POS	CHOICE 1	CHOICE 2	6-WAY ADAPTER			
CHEVROLET (Continued)																				
E3	118315	BN	5	7.5									A	PU3	119148	20252	20320	20321	20224	
E3	118315	BN	5	7.5									A	PU3	119148	20252	20320	20321	20224	
E3	118315	BN	5	7.5									A	PU3	119148	20252	20320	20321	20224	
E3	118315	BN	5	7.5									A	PU3	119148	20252	20320	20321	20224	
E3	118315	BN	5	7.5									A	PU3	119148	20252	20320	20321	20224	
E3	118315	BN	5	7.5									A	PU3	119148	20252	20320	20321	20224	
E3	118315	BN	5	7.5									A	PU3	119148	20252	20320	20321	20224	
E3	118315	BN	5	7.5									A	PU3	119148	20252	20320	20321	20224	
E3	118315	BN	5	7.5									A	PU3	119148	20252	20320	20321	20224	
E3	118315	BN	5	7.5									A	PU3	119148	20252	20320	20321	20224	
E3	118315	BN	5	7.5									A	PU3	119148	20252	20320	20321	20224	
E3	118315	BN	5	7.5									A	PC3,4	119148	20252				
E3	118315	BN	5	7.5									B	PC3,4	119130	119178				
E7	118439	BN	15	7.5									A	PC3,4	119148	20252				
E7	118450	BN	10	7.5									A	PC1,2	119148	20252				
E18	118604	CH	45	4.2,7.5	X								BM	PC3,4	119251	119191				
E16	118576	CH	45	2.1,5.6	X								B,E	PC3,4	119191	119148				
E18	118604	CH	45	4.2,7.5	X								B,E	PC3,4	119191	119148				
E17	118689	CH	45	4.2,7.5	X								BTT	PC3,4	119251	119191				

A 2 wire system.

B 3 wire system. Converter required.

BM Multiplexed wiring system. ModuLite® HD Plus or Ultra required.

BN Exterior mounted plug on some or all models. May require an aftermarket electrical mounting box or bracket. (Sold separately)

BTT Shared Brake/Tail/Turn multiplexed wiring system. ModuLite® HD Plus or Ultra required.

CH T-One is equipped with circuit protected ModuLite® module.

E ModuLite® required.

RT3 Round Tube Class III 2"

RT4 Round Tube Class IV 2"

SQ1 Square Tube Class I

SQ2 Square Tube Class II

SQ3 Square Tube Class III

SQ4 Square Tube Class IV

SQ5 Square Tube Class V

CHEVROLET

RECEIVER HITCHES

RECEIVER HITCH APPLICATION GUIDE

MODEL / STYLE	YEAR	TRAILER HITCHES									
		PC	REC TYPE	REC SIZE	PART NO.	NO DRILL	FOOTNOTES	OPTIONAL DRAWBAR	WC (LBS.)	WD (LBS.)	IN
CHEVROLET (Continued)											
Malibu Limited LTZ, Except Canada Models (Old Body Style)	16	42	SQ2	1-1/4	36538	0	HM	36061	300/3,500		35
Malibu Limited, Except LTZ & Canada Models (Old Body Style)	16	42	SQ2	1-1/4	36538	0	HM	36061	300/3,500		35
Malibu Premier (New Body Style)	16-19	23	SQ2	1-1/4	365921	0	GP,JR,EP,TA	36071	300/3,500		80
		20	SQ2	1-1/4	36652	0	GP,JR,AA,DU,X,TA	36071	350/3,500		80
Malibu Classic LS	08	42	SQ2	1-1/4	36317		JR,HM	36071	300/3,500		40
Malibu Classic LT	08	42	SQ2	1-1/4	36317		JR,HM	36071	300/3,500		40
Malibu LTZ	08-12	24	SQ2	1-1/4	36479		GP,JR,RB	36065	300/3,500		45
Malibu LTZ Except Canada Models	13	46	SQ2	1-1/4	365221	0	HM	36061	300/3,500		20
Malibu LTZ Except Canada Models	14-15	42	SQ2	1-1/4	36538	0	HM	36061	300/3,500		35
Malibu Maxx LS	04-07	34	SQ2	1-1/4	36379		HM	36071	300/3,500		25
Malibu Maxx LT	04-07	34	SQ2	1-1/4	36379		HM	36071	300/3,500		25
Malibu SS 4 Dr.	06-07	42	SQ2	1-1/4	36317		JR,X,HM	36071	300/3,500		50
		23	SQ1	1-1/4	24628		AI,GP	3592	200/2,000		30
Monte Carlo	95-99	48	SQ2	1-1/4	361931	0	JR,GP	36061	300/3,500		60
		45	SQ2	1-1/4	36292	0	JR,GP	36061	300/3,500		30
Monte Carlo Except SS Sport Appearance Pkg.	00-05	45	SQ2	1-1/4	36292	0	JR,GP	36061	300/3,500		30
Monte Carlo Except SS Sport Appearance Pkg.	06-07	45	SQ2	1-1/4	36292	0	JR,GP	36061	300/3,500		30
Orlando (Canada Only)	12-13	27	SQ1	1-1/4	24881	0	HM,JR,KH	3593	200/2,000		35
Prizm	98-02	25	SQ1	1-1/4	24579		GP	3593	200/2,000		30
S10 w/Standard Bed & Step Bumper	85-97	34	SQ2	1-1/4	36248	0	GU,HM,RH	36071	300/3,500		35
		34	SQ3	2	75051	0	GP,GU		350/3,500	750/6,000	40
		50	SQ3	2	37136		CN,GU,SB		500/5,000	600/6,000	30
S10 w/Sportside Bed & Non-Towing Bumper	96-97	30	SQ3	2	75085	0	GP		350/3,500	750/6,000	40
S10	98-04	34	SQ2	1-1/4	36248	0	GU,RH,GP	36071	300/3,500		35
		30	SQ3	2	75085	0	GP		350/3,500	750/6,000	40
		50	SQ3	2	37136		AF,CN,GU,ST		500/5,000	600/6,000	30
S10	13	51	SQ3	2	758101	0	GP		600/4,000	771/7,710	30
Silverado 1500	99-02	49	RT3	2	37133	0	RO		500/5,000	750/7,500	25
		39	SQ4	2	41534	0	RO		600/6,000	1,200/12,000	20
		54	RT4	2	37130	0	RO		700/7,000	1,200/12,000	25
		30	RT4	2	75362	0	JL,RO		900/6,000	900/8,000	15
		22	RT4	2	75521	0	JL,RO,SZ		900/6,000	1,050/10,500	15
		50	SQ5	2	41932	0	@,HM,JL,RO		1,200/12,000	1,400/14,000	20
Silverado 1500 w/Factory 7-Way	99-13										
Silverado 1500 (Classic)	03-07	49	RT3	2	37133	0			500/5,000	750/7,500	25
		39	SQ4	2	41534	0			600/6,000	1,200/12,000	20
		54	RT4	2	37130	0			700/7,000	1,200/12,000	25
		30	RT4	2	75362	0	JL		900/6,000	900/8,000	15
		22	RT4	2	75521	0	JL,SZ		900/6,000	1,050/10,500	15
		50	SQ5	2	41932	0	@,HM,JL		1,200/12,000	1,400/14,000	20
Silverado 1500	07-13	30	RT4	2	75362	0	JL		900/6,000	900/8,000	15
		22	RT4	2	75521	0	JL,SZ		900/6,000	1,050/10,500	15
Silverado 1500 LD (Old Body Style)	14-19	33	RT4	2	75866	0	HM,JL		900/6,000	1,200/12,000	20
		25	SQ4	2	76016	0	GP,JL		900/6,000	1,000/10,000	25
Silverado 1500 (New Body Style)	19										
Silverado 1500 HD	01-02	39	SQ4	2	41534	0			600/6,000	1,200/12,000	20
Silverado 1500 HD	01-03	49	RT3	2	37133	0			500/5,000	750/7,500	25
		54	RT4	2	37130	0			700/7,000	1,200/12,000	25
		30	RT4	2	75362	0	JL		900/6,000	900/8,000	15
		22	RT4	2	75521	0	JL,SZ		900/6,000	1,050/10,500	15
		50	SQ5	2	41932	0	@,HM,JL		1,200/12,000	1,400/14,000	20

@ Ultra Frame ball mount must be used to achieve maximum weight carrying rating.
AA Requires temporary removal of bumper during installation.
AF Hitch is ONLY rated for Weight Carrying at 3500 lbs. GTW / 350 lbs. TW and DO NOT use Weight Distribution Spring Bars for this Specific Vehicle. Except for long bed pickups.
AI Additional installation time may be required.
CN Requires OEM factory bumper for hitch installation.
DU Fascia removal required.
EP Fascia trimming may be required.
GP Hitch crosstube concealed behind bumper.
GU Will not fit vehicles with factory or aftermarket lower Fascia/Rollpan or Tube Bumper.
HM Hitch crosstube is visible beneath bumper.
JL Installation requires OEM bumper and brackets.

JR Exhaust must be temporarily lowered for installation.
KH Minor heat shield modification may be required.
RH Hitch installation can be made easier with a cutter type drill bit.
RB Optional drawbar #36051 required (Sold separately) except for models with ZR2 & Highrider package.
RO Will not fit Silverado SS.
SB Will not fit models with short bed.
ST Will not fit 2WD models with short bed.
SZ Hitches produced before 03/10/11 are rated at 600/6000 WC.
TA Trunk access required for hitch installation.
X Minor fascia trimming required.

T-ONE					TOW HARNESS					4-FLAT WIRING				REQ. 4 FLAT WIRING		7-WAY HARDWARE	BRAKE CONTROL HARNESS	IN			
PC	T-ONE	FN	IN	AMP	CP	PC	TOW HARN	FN	IN	AMP	CP	TYPE	ELEC	POS	CHOICE 1				CHOICE 2	6-WAY ADAPTER	7-WAY ADAPTER
CHEVROLET (Continued)																					
E17	118602	CH	45	2.1,5.6	X								B,E	PC3,4	119191	119148					
E18	118604	CH	45	4.2,7.5	X								B,E	PC3,4	119191	119148					
E15	118740	CH	45	5.7.5	X								A,E	PC3,4	119251	119191					
E7	118439	BN	15	7.5									A	PC3,4	119148	20252					
E7	118439	BN	15	7.5									A	PC3,4	119148	20252					
													A,E	PC1,2	119191	119148					
E17	118602	CH	45	2.1,5.6	X								B,E	PC3,4	119191	119148					
E17	118602	CH	45	2.1,5.6	X								B,E	PC3,4	119191	119148					
E7	118439	BN	15	7.5									A	PC3,4	119148	20252					
E7	118439	BN	15	7.5									A	PC3,4	119148	20252					
E7	118439	BN	15	7.5									A	PC3,4	119148	20252					
													A	PC3,4	119148	20252					
													B	PC4	119130	119178					
													A	PC3,4	119148	20252					
E16	118565	CH	45	2.1,5.6	X								B,E	SUV3,4	119191	119148	20320	20321			
													B	PC3,4	119130	119178					
E3	118312	BN	5	7.5									A	PU3	119148	20252	20320	20321	20224		
E3	118312	BN	5	7.5									A	PU3	119148	20252	20320	20321	20224		
E4	118359	BN	5	7.5									A	PU3	119148	20252	20320	20321	20224		
													B,E	PU1,2	119191	119148	20320	20321			
						E8	118384	BN,RD	5	7.5		4-Flat	A	PU3	119148	20252	20320	20321	20224	3025-P	5
							74682 8551511 85219	RD RD RD	10 5			Both 7-Way 7-Way	H	PU3	119148	20252					
						E8	118384	BN,RD	5	7.5		4-Flat	A	PU3	119148	20252	20320	20321	20224	3015-P	5
E8	118384	BN	5	7.5									A	PU3	119148	20252	20320	20321	20224		
E8	118384		5	7.5									A	PU3	119148	20252	20320	20321	20224	3016-P	5
													A	PU3	119148	20252	20320	20321	20224	3064-P	10
						E8	118384	BN,RD	5	7.5		4-Flat	A	PU3	119148	20252	20320	20321	20224	3025-P	5
						E8	118384	BN,RD	5	7.5		4-Flat	A	PU3	119148	20252	20320	20321	20224	3025-P	5

A 2 wire system.
B 3 wire system. Converter required.
BN Exterior mounted plug on some or all models. May require an aftermarket electrical mounting box or bracket. (Sold separately)
CH T-One is equipped with circuit protected ModuLite® module.

E ModuLite® required.
H 3 wire system with OEM standard 2 wire harness.
RD For vehicles equipped with factory tow package may require additional components or may be used as a replacement harness.

RT3 Round Tube Class III 2"
RT4 Round Tube Class IV 2"
SQ1 Square Tube Class I
SQ2 Square Tube Class II
SQ3 Square Tube Class III
SQ4 Square Tube Class IV
SQ5 Square Tube Class V

RECEIVER HITCH APPLICATION GUIDE

MODEL / STYLE	YEAR	TRAILER HITCHES									
		PC	REC TYPE	REC SIZE	PART NO.	NO DRILL	FOOTNOTES	OPTIONAL DRAWBAR	WC (LBS.)	WD (LBS.)	IN
CHEVROLET (Continued)											
Silverado 1500 HD w/Factory 7-Way	01-07										
Silverado 1500 HD (Classic)	03	39	SQ4	2	41534	0			600/6,000	1,200/12,000	20
Silverado 1500 HD (Classic)	05-07	49	RT3	2	37133	0			500/5,000	750/7,500	25
		39	SQ4	2	41534	0			600/6,000	1,200/12,000	20
		54	RT4	2	37130	0			700/7,000	1,200/12,000	25
		30	RT4	2	75362	0	JL		900/6,000	900/8,000	15
		22	RT4	2	75521	0	JL,SZ		900/6,000	1,050/10,500	15
	50	SQ5	2	41932	0	@,HM,JL		1,200/12,000	1,400/14,000	20	
Silverado 2500	99-02	49	RT3	2	37133	0			500/5,000	750/7,500	25
		39	SQ4	2	41534	0			600/6,000	1,200/12,000	20
		54	RT4	2	37130	0			700/7,000	1,200/12,000	25
		30	RT4	2	75362	0	JL		900/6,000	900/8,000	15
		22	RT4	2	75521	0	JL,SZ		900/6,000	1,050/10,500	15
		50	SQ5	2	41932	0	@,HM,JL		1,200/12,000	1,400/14,000	20
	58	SQ5	2-1/2	455121	0	#		1,200/12,000	1,700/14,000	20	
Silverado 2500 w/Factory 7-Way	99-04										
Silverado 2500	03-04	49	RT3	2	37133	0			500/5,000	750/7,500	25
		39	SQ4	2	41534	0			600/6,000	1,200/12,000	20
		54	RT4	2	37130	0			700/7,000	1,200/12,000	25
		30	RT4	2	75362	0	JL		900/6,000	900/8,000	15
		22	RT4	2	75521	0	JL,SZ		900/6,000	1,050/10,500	15
		50	SQ5	2	41932	0	@,HM,JL		1,200/12,000	1,400/14,000	20
		58	SQ5	2-1/2	455121	0	#		1,200/12,000	1,700/14,000	20
Silverado 2500 HD	01-02	46	SQ4	2	41544	0	HM,SA		600/6,000	1,200/12,000	20
		34	RT4	2	75550	0	CS,FS,JL,LT		600/6,000	1,100/11,000	20
		37	SQ5	2	41944	0	@,CS,FS,HM,LT		1,950/13,000	1,600/16,000	25
		58	SQ5	2-1/2	45517	0	#,CS,FS,LT		1,300/13,000	1,700/17,000	25
Silverado 2500 HD 8 ft. Bed	01-02	60	SQ5	2-1/2	45519	0	#,CS,FS,LT		2,000/18,000	2,500/18,000	25
Silverado 2500 HD w/Factory 7-Way	01-19										
Silverado 2500 HD (Classic)	03-07	46	SQ4	2	41544	0	HM,SA		600/6,000	1,200/12,000	20
		34	RT4	2	75550	0	CS,FS,JL,LT		600/6,000	1,100/11,000	20
		37	SQ5	2	41944	0	@,CS,FS,HM,LT		1,950/13,000	1,600/16,000	25
		58	SQ5	2-1/2	45517	0	#,CS,FS,LT		1,300/13,000	1,700/17,000	25
Silverado 2500 HD 8 ft. Bed (Classic)	03-07	60	SQ5	2-1/2	45519	0	#,CS,FS,LT		2,000/18,000	2,500/18,000	25
Silverado 2500 HD	07-10	34	RT4	2	75550	0	CS,FS,JL,LT		600/6,000	1,100/11,000	20
		37	SQ5	2	41944	0	@,CS,FS,HM,LT		1,950/13,000	1,600/16,000	25
		58	SQ5	2-1/2	45517	0	#,CS,FS,LT		1,300/13,000	1,700/17,000	25
Silverado 2500 HD 8 ft. Bed	07-10	60	SQ5	2-1/2	45519	0	#,CS,FS,LT		2,000/18,000	2,500/18,000	25
Silverado 2500 HD	11-14	43	SQ4	2	75707	0	CS,FS,GP,JL,LT		800/8,000	1,200/12,000	20
		50	SQ5	2	41942	0	@,CS,FS,GP,JL,KH,LT		1,500/15,000	1,600/16,000	20
		67	SQ5	2-1/2	45510	0	#,CS,FS,HM,JL,KH,LT		2,000/18,000	2,500/18,000	60
Silverado 2500 HD	15-19	42	SQ4	2	75906	0	HM,JL		1,200/8,000	1,200/12,000	30
		53	SQ5	2	41950	0	@,CS,FS,GP,JL,KH,LT		1,700/15,000	1,700/17,000	60
		57	SQ5	2-1/2	45511	0	#,HM		2,700/20,000	2,700/20,000	60

Titan hitches require use of a 2-1/2" shank Titan ball mount.
 @ Ultra Frame ball mount must be used to achieve maximum weight carrying rating.
 CS Will fit with full-size spare tire stowed under vehicle.
 FS Includes 2 & 4 WD models with heavy duty suspension.
 GP Hitch cross-tube concealed behind bumper.
 HM Hitch cross-tube is visible beneath bumper.

JL Installation requires OEM bumper and brackets.
 KH Minor heat shield modification may be required.
 LT Requires removal of factory hitch if equipped.
 SA Requires drilling on 6 ft. bed models.
 SZ Hitches produced before 03/10/11 are rated at 600/6000 WC.

T-ONE						TOW HARNESS						4-FLAT WIRING				REQ. 4 FLAT WIRING		7-WAY HARDWIRE	BRAKE CONTROL HARNESS	IN	
PC	T-ONE	FN	IN	AMP	CP	PC	TOW HARN	FN	IN	AMP	CP	TYPE	ELEC	POS	CHOICE 1	CHOICE 2	6-WAY ADAPTER				7-WAY ADAPTER
CHEVROLET (Continued)																					
							85219 74682 8551511	RD RD RD	5 10			7-Way Both 7-Way	H	PU3	119148	20252					
						E8	118384	BN,RD	5	7.5		4-Flat	A	PU3	119148	20252	20320	20321	20224	3015-P	5
						E8	118384	BN,RD	5	7.5		4-Flat	A	PU3	119148	20252	20320	20321	20224	3015-P	5
						E8	118384	BN,RD	5	7.5		4-Flat	A	PU3	119148	20252	20320	20321	20224	3025-P	5
							74682 85219 8551511	RD RD RD	10 5			Both 7-Way 7-Way	H	PU3	119148	20252					
						E8	118384	BN,RD	5	7.5		4-Flat	A	PU3	119148	20252	20320	20321	20224	3015-P	5
						E8	118384	BN,RD	5	7.5		4-Flat	A	PU3	119148	20252	20320	20321	20224	3025-P	5
						E8	118384	BN,RD	5	7.5		4-Flat	A	PU3	119148	20252	20320	20321	20224	3025-P	5
							85219 8551511 74682	RD RD RD	5 10			7-Way 7-Way Both	H	PU3	119148	20252					
						E8	118384	BN,RD	5	7.5		4-Flat	A	PU3	119148	20252	20320	20321	20224	3015-P	5
E8	118384	BN	5	7.5		E8	118384	BN,RD	5	7.5		4-Flat	A	PU3	119148	20252	20320	20321	20224	3015-P	5
E8	118384	BN	5	7.5									A	PU3	119148	20252	20320	20321	20224		
E8	118384	BN	5	7.5									A	PU3	119148	20252	20320	20321	20224		
E8	118384	BN	5	7.5									A	PU3	119148	20252	20320	20321	20224	3016-P	5

A 2 wire system.
BN Exterior mounted plug on some or all models. May require an aftermarket electrical mounting box or bracket. (Sold separately)
H 3 wire system with OEM standard 2 wire harness.
RD For vehicles equipped with factory tow package may require additional components or may be used as a replacement harness.

RT3 Round Tube Class III 2"
RT4 Round Tube Class IV 2"
SQ4 Square Tube Class IV
SQ5 Square Tube Class V

CHEVROLET

RECEIVER HITCHES

RECEIVER HITCH APPLICATION GUIDE

MODEL / STYLE	YEAR	TRAILER HITCHES									
		PC	REC TYPE	REC SIZE	PART NO.	NO DRILL	FOOTNOTES	OPTIONAL DRAWBAR	WC (LBS.)	WD (LBS.)	IN
CHEVROLET (Continued)											
Silverado 3500	01-02	46	SQ4	2	41544	0	HM,SA		600/6,000	1,200/12,000	20
		34	RT4	2	75550	0	CS,FS,J,LLT		600/6,000	1,100/11,000	20
		37	SQ5	2	41944	0	@,CS,FS,HM,LT		1,950/13,000	1,600/16,000	25
		58	SQ5	2-1/2	45517	0	#,CS,FS,LT		1,300/13,000	1,700/17,000	25
		60	SQ5	2-1/2	45519	0	#,CS,FS,LT		2,000/18,000	2,500/18,000	25
Silverado 3500 Cab & Chassis, w/34" Wide Frames (Classic)	01-07	29	SQ5	2	41936		@		1,200/12,000		30
		50	SQ5	2	41938		@,CC		1,200/12,000	1,500/15,000	40
		55	SQ5	2	41947		@		1,600/15,000	1,600/16,000	35
Silverado 3500 w/Factory 7-Way	01-07										
Silverado 3500 (Classic)	03-07	46	SQ4	2	41544	0	HM,SA		600/6,000	1,200/12,000	20
		34	RT4	2	75550	0	CS,FS,J,LLT		600/6,000	1,100/11,000	20
		37	SQ5	2	41944	0	@,CS,FS,HM,LT		1,950/13,000	1,600/16,000	25
		58	SQ5	2-1/2	45517	0	#,CS,FS,LT		1,300/13,000	1,700/17,000	25
		60	SQ5	2-1/2	45519	0	#,CS,FS,LT		2,000/18,000	2,500/18,000	25
Silverado 3500 HD	07-10	34	RT4	2	75550	0	CS,FS,J,LLT		600/6,000	1,100/11,000	20
		37	SQ5	2	41944	0	@,CS,FS,HM,LT		1,950/13,000	1,600/16,000	25
		58	SQ5	2-1/2	45517	0	#,CS,FS,LT		1,300/13,000	1,700/17,000	25
		60	SQ5	2-1/2	45519	0	#,CS,FS,LT		2,000/18,000	2,500/18,000	25
Silverado 3500 HD Cab & Chassis, w/34" Wide Frames	07-17	29	SQ5	2	41936		@		1,200/12,000		30
		50	SQ5	2	41938		@,CC		1,200/12,000	1,500/15,000	40
		55	SQ5	2	41947		@		1,600/15,000	1,600/16,000	35
Silverado 3500 HD w/Factory 7-Way	07-19										
Silverado 3500 HD	11-14	43	SQ4	2	75707	0	CS,FS,GP,J,LLT		800/8,000	1,200/12,000	20
		50	SQ5	2	41942	0	@,CS,FS,GP,JL,KH,LT		1,500/15,000	1,600/16,000	20
		67	SQ5	2-1/2	45510		#,CS,FS,HM,JL,KH,LT		2,000/18,000	2,500/18,000	60
Silverado 3500 HD	15-17	42	SQ4	2	75906	0	HM,JL		1,200/8,000	1,200/12,000	30
		53	SQ5	2	41950	0	@,CS,FS,GP,JL,KH,LT		1,700/15,000	1,700/17,000	60
		57	SQ5	2-1/2	45511		#,HM		2,700/20,000	2,700/20,000	60
Sonic 4 Dr. Sedan	12-16	20	SQ1	1-1/4	24876	0	GP	3590	200/2,000		20
Sonic 5 Dr. Hatchback	12-16	25	SQ1	1-1/4	24878	0	HB,HM,JR	3590	200/2,000		20
Sonic 4 Dr. Sedan	17	20	SQ1	1-1/4	24876	0	GP	3590	200/2,000		20
Sonic 5 Dr. Hatchback	17-19	25	SQ1	1-1/4	24878	0	HB,HM,JR	3590	200/2,000		20
Spark Except w/Ground Effects	13-15	24	SQ1	1-1/4	24893		GP,JR	3594	200/2,000		25
Spark	16	18	SQ1	1-1/4	24941	0	DU,GP,X	3593	200/2,000		45
Spark	17-19	18	SQ1	1-1/4	24941	0	DU,GP,X	3593	200/2,000		45
Spark LT w/Ground Effects	13-15	24	SQ1	1-1/4	24894		GP,JR	3594	200/2,000		25
Suburban w/Factory 7-Way	00-11										
Suburban	07-11										
Suburban	15-17										
Suburban 1500 w/Amber Turn Signals	00-02	50	SQ3	2	37136				500/5,000	600/6,000	30
		29	RT4	2	75725	0	CN,HM		900/6,000	1,000/10,000	15
		30	SQ5	2	41930		@,CN,HM		1,000/10,000	1,200/12,000	35
Suburban 1500 w/Amber Turn Signals	03-06	50	SQ3	2	37136				500/5,000	600/6,000	30
		29	RT4	2	75725	0	CN,HM		900/6,000	1,000/10,000	15
		30	SQ5	2	41930		@,CN,HM		1,000/10,000	1,200/12,000	35

Titan hitches require use of a 2-1/2" shank Titan ball mount.
 @ Ultra Frame ball mount must be used to achieve maximum weight carrying rating.
 CC Requires minimum of 19 in. from end of frame rail to spring shackle bracket.
 CN Requires OEM factory bumper for hitch installation.
 CS Will fit with full-size spare tire stowed under vehicle.
 DU Fascia removal required.
 FS Includes 2 & 4 WD models with heavy duty suspension.
 GP Hitch cross-tube concealed behind bumper.

HB Slight fascia deformation may occur on some models.
 HM Hitch cross-tube is visible beneath bumper.
 JL Installation requires OEM bumper and brackets.
 JR Exhaust must be temporarily lowered for installation.
 KH Minor heat shield modification may be required.
 LT Requires removal of factory hitch if equipped.
 SA Requires drilling on 6 ft. bed models.
 X Minor fascia trimming required.

T-ONE					TOW HARNESS							4-FLAT WIRING				REQ. 4 FLAT WIRING		7-WAY HARDWIRE	BRAKE CONTROL HARNESS	IN	
PC	T-ONE	FN	IN	AMP	CP	PC	TOW HARN	FN	IN	AMP	CP	TYPE	ELEC	POS	CHOICE 1	CHOICE 2	6-WAY ADAPTER				7-WAY ADAPTER
CHEVROLET (Continued)																					
						E8	118384	BN,RD	5	7.5		4-Flat	A	PU3	119148	20252	20320	20321	20224	3025-P	5
													C	PU1,2	119191	119148	20320	20321	20224		
							74682 8551511 85219	RD RD RD	10 5			Both 7-Way 7-Way	H	PU3	119148	20252					
						E8	118384	BN,RD	5	7.5		4-Flat	A	PU3	119148	20252	20320	20321	20224	3015-P	5
E8	118384	BN	5	7.5									A	PU3	119148	20252	20320	20321	20224		
													C	PU1,2	119191	119148	20320	20321	20224		
							85219 8551511 74682	RD RD RD	5 10			7-Way 7-Way Both	A	PU3	119148	20252					
E8	118384	BN	5	7.5									A	PU3	119148	20252	20320	20321	20224		
E8	118384	BN	5	7.5									A	PU3	119148	20252	20320	20321	20224	3016-P	5
E19	118640	CH	45	4.2,7.5	X								BT	PC3,4	119251	119191					
E19	118640	CH	45	4.2,7.5	X								BT	PC3,4	119251	119191					
E17	118755	CH	45	5.7,5	X								BT	PC3,4	119251	119191					
E17	118755	CH	45	5.7,5	X								BT	PC3,4	119251	119191					
E19	118575	CH	45	2.1,5.6	X								BM	PC3,4	119251	119191					
E18	118694	CH	45	4.2,7.5	X								BT	PC3,4	119251	119191					
													BT	PC3,4	119251	119191					
E19	118575	CH	45	2.1,5.6	X								BM	PC3,4	119251	119191					
							74682 8551511 85219	RD RD RD	10 5			Both 7-Way 7-Way	H	SUV6	119148	20252					
						E8	118384	BN,RD	5	7.5		4-Flat	H	SUV6	119148	20252					
																				3016-P	5
E8	118384	BN	5	7.5									A	SUV6	119148	20252	20320	20321	20224	3025-P	5
E8	118384	BN	5	7.5									A	SUV6	119148	20252	20320	20321	20224	3015-P	5

A 2 wire system.

BM Multiplexed wiring system. ModuLite® HD Plus or Ultra required.

BN Exterior mounted plug on some or all models. May require an aftermarket electrical mounting box or bracket. (Sold separately)

BT Shared Brake/Tail multiplexed wiring system. ModuLite® HD Plus or Ultra required.

C 2 or 3 wire system determine at installation.

CH T-One is equipped with circuit protected ModuLite® module.

H 3 wire system with OEM standard 2 wire harness.

RD For vehicles equipped with factory tow package may require additional components or may be used as a replacement harness.

RT4 Round Tube Class IV 2"

SQ1 Square Tube Class I

SQ3 Square Tube Class III

SQ4 Square Tube Class IV

SQ5 Square Tube Class V

RECEIVER HITCH APPLICATION GUIDE

MODEL / STYLE	YEAR	TRAILER HITCHES									
		PC	REC TYPE	REC SIZE	PART NO.	NO DRILL	FOOTNOTES	OPTIONAL DRAWBAR	WC (LBS.)	WD (LBS.)	IN
CHEVROLET (Continued)											
Suburban 2500 w/Amber Turn Signals	00-02	50	SQ3	2	37136	0	CN,HM @,CN,HM #		500/5,000	600/6,000	30
		29	RT4	2	75725				900/6,000	1,000/10,000	15
		30	SQ5	2	41930				1,000/10,000	1,200/12,000	35
		53	SQ5	2-1/2	45515				1,200/12,000	1,700/14,000	50
Suburban 2500 w/Amber Turn Signals	03-06	50	SQ3	2	37136	0	CN,HM @,CN,HM		500/5,000	600/6,000	30
		29	RT4	2	75725				900/6,000	1,000/10,000	15
		30	SQ5	2	41930				1,000/10,000	1,200/12,000	35
Suburban C1500	92-99	50	SQ3	2	37136		HM		500/5,000	600/6,000	30
		35	SQ3	2	75037				500/5,000	750/7,500	30
		41	SQ4	2	41511				600/6,000	1,000/10,000	30
Suburban C2500	92-99	50	SQ3	2	37136		HM		500/5,000	600/6,000	30
		35	SQ3	2	75037				500/5,000	750/7,500	30
		41	SQ4	2	41511				600/6,000	1,000/10,000	30
Suburban K1500	92-99	50	SQ3	2	37136		HM		500/5,000	600/6,000	30
		35	SQ3	2	75037				500/5,000	750/7,500	30
		41	SQ4	2	41511				600/6,000	1,000/10,000	30
Suburban K2500	92-99	50	SQ3	2	37136		HM		500/5,000	600/6,000	30
		35	SQ3	2	75037				500/5,000	750/7,500	30
		41	SQ4	2	41511				600/6,000	1,000/10,000	30
Tahoe	95-00	50	SQ3	2	37136		HM		500/5,000	600/6,000	30
		35	SQ3	2	75037				500/5,000	750/7,500	30
		41	SQ4	2	41511				600/6,000	1,000/10,000	30
Tahoe w/Amber Turn Signals	00-02	50	SQ3	2	37136	0	CN,HM		500/5,000	600/6,000	30
		29	RT4	2	75725				900/6,000	1,000/10,000	15
Tahoe w/Factory 7-Way	00-11										
Tahoe w/Amber Turn Signals	03-06	50	SQ3	2	37136	0	CN,HM		500/5,000	600/6,000	30
		29	RT4	2	75725				900/6,000	1,000/10,000	15
Tahoe	07-11										
Tahoe	15-16										
Tracker	98	24	SQ1	1-1/4	24622	0	HM	3593	200/2,000		20
Tracker	99-04	29	SQ1	1-1/4	24673	0	HM	3591	200/2,000		15
		29	SQ3	2	41537	0	HM		350/3,500		15
TrailBlazer w/Factory 7-Way	02-09										
Traverse	09-12	19	RT3	2	75528	0	GP,JR,TN		750/5,000	750/7,500	25
Traverse w/Factory 7-Way	09-12										
Traverse	13-17	19	RT3	2	75528	0	GP,JR,TN		750/5,000	750/7,500	25
Traverse	18-19	30	SQ3	2	76184	0	DU,JR		750/5,000	750/5,000	75
Trax	13-16	25	RT2	1-1/4	36554	0	HM,JR	36061	300/3,500		40
Trax Except LS	17-19	25	RT2	1-1/4	36554	0	HM,JR	36061	300/3,500		40
Trax LS	17-19	25	RT2	1-1/4	36554	0	HM,JR	36061	300/3,500		40
Uplander	05-08	27	SQ2	1-1/4	36361		AL,GP,JR	36061	300/3,500		40
		22	SQ3	2	75278				350/3,500	500/5,000	40
Uplander (Canada Only)	09	27	SQ2	1-1/4	36361		AL,GP,JR	36061	300/3,500		40
		22	SQ3	2	75278				350/3,500	500/5,000	40

Titan hitches require use of a 2-1/2" shank Titan ball mount.

@ Ultra Frame ball mount must be used to achieve maximum weight carrying rating.

AL Additional installation time required for vehicles equipped with load leveling compressor.

CN Requires OEM factory bumper for hitch installation.

DU Fascia removal required.

GP Hitch crosstube concealed behind bumper.

HM Hitch crosstube is visible beneath bumper.

JR Exhaust must be temporarily lowered for installation.

TN Hitches produced before 07/09/12 are rated at 500/5000 WC & 500/5000 WD.

T-ONE					TOW HARNESS							4-FLAT WIRING				REQ. 4 FLAT WIRING		7-WAY HARDWARE	BRAKE CONTROL HARNESS	IN	
PC	T-ONE	FN	IN	AMP	CP	PC	TOW HARN	FN	IN	AMP	CP	TYPE	ELEC	POS	CHOICE 1	CHOICE 2	6-WAY ADAPTER				7-WAY ADAPTER
CHEVROLET (Continued)																					
E8	118384	BN	5	7.5									A	SUV6	119148	20252	20320	20321	20224	3025-P	5
E8	118384	BN	5	7.5									A	SUV6	119148	20252	20320	20321	20224	3015-P	5
E3	118319	BN	5	7.5									A	SUV6	119148	20252	20320	20321	20224		
E3	118319	BN	5	7.5									A	SUV6	119148	20252	20320	20321	20224		
E3	118319	BN	5	7.5									A	SUV6	119148	20252	20320	20321	20224		
E3	118319	BN	5	7.5									A	SUV6	119148	20252	20320	20321	20224		
E3	118319	BN	5	7.5									A	SUV6	119148	20252	20320	20321	20224		
E8	118384	BN	5	7.5									A	SUV6	119148	20252	20320	20321	20224	3025-P	5
							74682	RD	10			Both	H	SUV6	119148	20252					
							8551511	RD				7-Way									
							85219	RD	5			7-Way									
E8	118384	BN	5	7.5									A	SUV6	119148	20252	20320	20321	20224	3015-P	5
						E8	118384	BN,RD	5	7.5		4-Flat	H	SUV6	119148	20252					
																				3016-P	5
E5	118372	HG	5	2.1,5									B	SUV1,2	119130	119178					
E5	118372	HG	5	2.1,5									B	SUV3	119130	119178	20320	20321	20224		
						E8	118384	BN,RD	5	7.5		4-Flat	H	SUV6	119148	20252					
							74682	RD	10			Both									
							8551511	RD				7-Way									
							85219	RD	5			7-Way									
E7	118450	BN	10	7.5		E8	118384	BN,RD	5	7.5		4-Flat	N	SUV1,2		119251	20320	20321		3026-P	5
							8551511	RD				7-Way	N	SUV6		119251					
							85219	RD	5			7-Way									
							74682	RD	10			Both									
E10	118270	BN	20	7.5		E16	118271	BN	20			7-Way	B,E	SUV1,2	119191	119148	20320	20321	20224	3026-P	5
E4	118761	BN,CH	15	7.5	X	E9	118287	BN	15			7-Way	A	SUV5							
E16	118659	CH	45	4.2,7.5	X								B,E	SUV3,4	119191	119148	20320	20321			
E16	118751	CH	45	4.2,7.5	X								B,E	SUV3,4	119191	119148	20320	20321			
E16	118659	CH	45	4.2,7.5	X								B,E	SUV3,4	119191	119148	20320	20321			
E10	118396	BN	15	7.5									A	SUV1,2	119148	20252	20320	20321	20224		
E10	118396	BN	15	7.5									A	SUV1,2	119148	20252	20320	20321	20224		

A 2 wire system.
B 3 wire system. Converter required.
BN Exterior mounted plug on some or all models. May require an aftermarket electrical mounting box or bracket. (Sold separately)
CH T-One is equipped with circuit protected ModuLite® module.
E ModuLite® required.

H 3 wire system with OEM standard 2 wire harness.
HG T-One incorporates taillight converter.
N DO NOT cut or splice vehicle wiring. Only use approved T-One or see auto dealer for trailer tow wiring kit.
RD For vehicles equipped with factory tow package may require additional components or may be used as a replacement harness.

RT2 Round Tube Class II 1-1/4"
RT3 Round Tube Class III 2"
RT4 Round Tube Class IV 2"
SQ1 Square Tube Class I
SQ2 Square Tube Class II
SQ3 Square Tube Class III
SQ4 Square Tube Class IV
SQ5 Square Tube Class V

CHEVROLET

RECEIVER HITCHES

RECEIVER HITCH APPLICATION GUIDE

MODEL / STYLE	YEAR	TRAILER HITCHES									
		PC	REC TYPE	REC SIZE	PART NO.	NO DRILL	FOOTNOTES	OPTIONAL DRAWBAR	WC (LBS.)	WD (LBS.)	IN
CHEVROLET (Continued)											
Venture	97-05	27	SQ1	1-1/4	24721†		AL,GP,JR	3592	200/2,000		30
		27	SQ2	1-1/4	36361		AL,GP,JR	36061	300/3,500		40
		22	SQ3	2	75278		AL,GP,JR		350/3,500	500/5,000	40
Volt	16-19	16	SQ1		24947	0	GP,DU,SV,JR	3593	200/2,000		60
CHRYSLER											
200 4 Dr. Sedan	11	28	SQ1	1-1/4	24871	0	GP,JR	3594	200/2,000		15
200 Convertible	11	28	SQ1	1-1/4	24871	0	GP,JR	3594	200/2,000		15
200 4 Dr. Sedan	12-14	28	SQ1	1-1/4	24871	0	GP,JR	3594	200/2,000		15
200 Convertible	12-14	28	SQ1	1-1/4	24871	0	GP,JR	3594	200/2,000		15
200 4 Dr. Sedan	15-17	27	SQ1	1-1/4	24919	0	GP,SV	3593	200/2,000		20
300	05-07	25	SQ2	1-1/4	36548	0	HM	36061	300/3,500		30
		23	SQ3	2	76145	0	HM		675/4,500		30
300	08-10	25	SQ2	1-1/4	36548	0	HM	36061	300/3,500		30
		23	SQ3	2	76145	0	HM		675/4,500		30
300	11-14	25	SQ2	1-1/4	36548	0	HM	36061	300/3,500		40
		23	SQ3	2	76145	0	HM		675/4,500		40
300	15-19	25	SQ2	1-1/4	36548	0	HM	36061	300/3,500		30
		23	SQ3	2	76145	0	HM		675/4,500		30
300 C	05-07										
300 C	11-14										
300M	99-01	35	SQ2	1-1/4	36275†		HM,JR	36071	300/3,500		30
300M Except Special	02-04	35	SQ2	1-1/4	36275†		HM,JR	36071	300/3,500		30
Aspen	07-08	18	SQ4	2	75162		AI		600/6,000	900/9,000	50
Aspen w/Factory 7-Way	07-08										
Aspen	09	18	SQ4	2	75162		AI		600/6,000	900/9,000	50
Aspen w/Factory 7-Way	09										
Cirrus	95-00	40	SQ2	1-1/4	36301		JR,HM	36061	300/3,500		60
Concorde	93-97	43	SQ2	1-1/4	36170†		JR,TA,HM	36061	300/3,500		40
Concorde	98-01	42	SQ2	1-1/4	36270†		†,HM	36071	300/3,500		35
Concorde	02	34	SQ2	1-1/4	36274		JR,GP	36061	300/3,500		30
Concorde	03-04	34	SQ2	1-1/4	36274		JR,GP	36061	300/3,500		30
Intrepid (Canada Only)	93-97	43	SQ2	1-1/4	36170†		JR,TA,HM	36061	300/3,500		40
Intrepid (Canada Only)	98-04	37	SQ2	1-1/4	36268†		JR,HM	36053	300/3,500		30
LHS	94-97	43	SQ2	1-1/4	36170†		JR,TA,HM	36063	300/3,500		40
LHS	99	34	SQ2	1-1/4	36274		JR,GP	36061	300/3,500		30
LHS	00-01	34	SQ2	1-1/4	36274		JR,GP	36061	300/3,500		30
Pacifica	04-08	37	RT3	2	75522	0	JR		350/3,500	500/5,000	45
Pacifica w/Factory 7-Way	04-08										
Pacifica Hybrid (Needs Conversion Kit: 76046SK)	17-19	26	RT2	1-1/4	36798	0	GP,JR,SV,KH,TW	36071	300/3,500		45
		28	RT3	2	76046	0	GP,JR,SV,KH,TW		675/4,500	675/5,000	45
Pacifica Limited	17-19	26	RT2	1-1/4	36798	0	GP,JR,SV,KH,TW	36071	300/3,500		45
		28	RT3	2	76046	0	GP,JR,SV,KH,TW		675/4,500	675/5,000	45
Pacifica LX	17-19	26	RT2	1-1/4	36798	0	GP,JR,SV,KH,TW	36071	300/3,500		45
		28	RT3	2	76046	0	GP,JR,SV,KH,TW		675/4,500	675/5,000	45
Pacifica Touring	17-19	26	RT2	1-1/4	36798	0	GP,JR,SV,KH,TW	36071	300/3,500		45
		28	RT3	2	76046	0	GP,JR,SV,KH,TW		675/4,500	675/5,000	45
Pacifica Touring L	17-19	26	RT2	1-1/4	36798	0	GP,JR,SV,KH,TW	36071	300/3,500		45
		28	RT3	2	76046	0	GP,JR,SV,KH,TW		675/4,500	675/5,000	45
Pacifica Touring L Plus	17-19	26	RT2	1-1/4	36798	0	GP,JR,SV,KH,TW	36071	300/3,500		45
		28	RT3	2	76046	0	GP,JR,SV,KH,TW		675/4,500	675/5,000	45
Pacifica Touring Plus	17-19	26	RT2	1-1/4	36798	0	GP,JR,SV,KH,TW	36071	300/3,500		45
		28	RT3	2	76046	0	GP,JR,SV,KH,TW		675/4,500	675/5,000	45

† Available while supply lasts.

AI Additional installation time may be required.

AL Additional installation time required for vehicles equipped with load leveling compressor.

DU Fascia removal required.

GP Hitch cross-tube concealed behind bumper.

HM Hitch cross-tube is visible beneath bumper.

JR Exhaust must be temporarily lowered for installation.

KH Minor heat shield modification may be required.

SV Trimming or removal of under body appearance panel may be required.

TA Trunk access required for hitch installation.

TW Receiver hitch may limit hands-free liftgate sensor range.

T-ONE						TOW HARNESS						4-FLAT WIRING				REQ. 4 FLAT WIRING		7-WAY HARDWIRE	BRAKE CONTROL HARNESS	IN		
PC	T-ONE	FN	IN	AMP	CP	PC	TOW HARN	FN	IN	AMP	CP	TYPE	ELEC	POS	CHOICE 1	CHOICE 2	6-WAY ADAPTER				7-WAY ADAPTER	
CHEVROLET (Continued)																						
E8	118355	HG	10	2.1,5									B	SUV3	119130	119178	20320	20321	20224			
E17	118726	CH,BN	45	5.7,5	X								B,E	PC1,2	119191	119148						
CHRYSLER																						
E18	118550	BN,CH	45	2.1,5,6	X								B,E	PC1,2	119191	119148						
E18	118550	BN,CH	45	2.1,5,6	X								B,E	PC1,2	119191	119148						
E17	118577	CH	45	2.1,5,6	X								N	PC1,2		119251						
E17	118577	CH	45	2.1,5,6	X								N	PC1,2		119251						
E15	118638	CH	45	2.1,5,6	X								A,E	PC3,4	119191	119148						
E7	118404		10	7.5									A	PC3,4	119148	20252						
E14	118406	CH	15	2.1,5,6	X								B,E	PC3,4	119191	119148						
E16	118600	CH	25	2.1,5,6	X								N	PC3,4		119251						
E15	118658	CH	45	4.2,7,5	X								A,E	PC3,4	119191	119148						
E14	118406	CH	15	2.1,5,6	X								B,E	PC3,4	119191	119148						
E16	118600	CH	25	2.1,5,6	X								N	PC3,4		119251						
E12	118364	BN,HG	15	2.1,5									B	PC1,2	119130	119178						
E12	118364	BN,HG	15	2.1,5									B	PC1,2	119130	119178						
E15	118390	BN,CH	45	2.1,5,6	X	E3	118381	BN,RD	5	7.5		4-Flat	B,E	SUV1,2	119191	119148	20320	20321	20224	3020-P	5	
							20135	RD	10			Both	H	SUV6	119148	20252						
E15	118390	BN,CH	45	2.1,5,6	X	E8	118384	BN,RD	5	7.5		4-Flat	B,E	SUV1,2	119191	119148	20320	20321	20224	3020-P	5	
							74682	RD	10			Both	H	SUV6	119148	20252						
							85219	RD	5			7-Way										
													B	PC3,4	119130	119178						
													B	PC3,4	119130	119178						
E12	118364	BN,HG	15	2.1,5									B	PC1,2	119130	119178						
E12	118364	BN,HG	15	2.1,5									B	PC1,2	119130	119178						
													B	PC1,2	119130	119178						
													B	PC3,4	119130	119178						
E12	118364	BN,HG	15	2.1,5									B	PC1,2	119130	119178						
													B	PC3,4	119130	119178						
E12	118364	BN,HG	15	2.1,5									B	PC3,4	119130	119178						
													B	PC3,4	119130	119178						
E17	118303	BN,CH	25	2.1,5,6	X	E3	118381	BN,RD	5	7.5		4-Flat	B,E	SUV1,2	119191	119148	20320	20321	20224			
							20135	RD	10			Both	H	SUV6	119148	20252						
																					3045-P	5
E15	118712	CH,BN	45	4.2,7,5	X								A,E	SUV1,2	119191	119148					3045-P	5
E18	118723	CH,BN	45		X								A,E	SUV1,2	119191	119148					3045-P	5
E18	118723	CH,BN	45		X								A,E	SUV1,2	119191	119148					3045-P	5
E15	118712	CH,BN	45	4.2,7,5	X								A,E	SUV1,2	119191	119148					3045-P	5
E15	118712	CH,BN	45	4.2,7,5	X								A,E	SUV1,2	119191	119148					3045-P	5
E15	118712	CH,BN	45	4.2,7,5	X								A,E	SUV1,2	119191	119148					3045-P	5

A 2 wire system.
B 3 wire system. Converter required.
BN Exterior mounted plug on some or all models. May require an aftermarket electrical mounting box or bracket. (Sold separately)
CH T-One is equipped with circuit protected ModuLite® module.
E ModuLite® required.

H 3 wire system with OEM standard 2 wire harness.
HG T-One incorporates taillight converter.
N DO NOT cut or splice vehicle wiring. Only use approved T-One or see auto dealer for trailer tow wiring kit.
RD For vehicles equipped with factory tow package may require additional components or may be used as a replacement harness.

RT2 Round Tube Class II 1-1/4"
RT3 Round Tube Class III 2"
SQ1 Square Tube Class I
SQ2 Square Tube Class II
SQ3 Square Tube Class III
SQ4 Square Tube Class IV

CHRYSLER

RECEIVER HITCHES

RECEIVER HITCH APPLICATION GUIDE

MODEL / STYLE	YEAR	TRAILER HITCHES									
		PC	REC TYPE	REC SIZE	PART NO.	NO DRILL	FOOTNOTES	OPTIONAL DRAWBAR	WC (LBS.)	WD (LBS.)	IN
CHRYSLER (Continued)											
PT Cruiser	01-04	31	SQ1	1-1/4	24759		JR,GP	3593	200/2,000		30
PT Cruiser	05-10	31	SQ1	1-1/4	24759		JR,GP	3593	200/2,000		30
PT Cruiser Convertible	05-09	31	SQ1	1-1/4	24759		JR,GP	3593	200/2,000		30
Sebring 4 Dr.	01-06	40	SQ2	1-1/4	36301		JR,HM	36061	300/3,500		60
Sebring Convertible	01-06	28	SQ1	1-1/4	24711		GP	3592	200/2,000		15
Sebring Convertible	07-10	28	SQ1	1-1/4	24871	0	GP,JR	3594	200/2,000		15
Sebring Except Convertible	07-10	28	SQ1	1-1/4	24871	0	GP,JR	3594	200/2,000		15
		30	SQ2	1-1/4	36448		GP,JR	36065	300/3,500		30
Town & Country	96-00	23	SQ2	1-1/4	36296	0	GP	36071	300/3,500		30
		30	RT3	2	75119				350/3,500	500/5,000	30
		50	SQ3	2	37136				500/5,000	600/6,000	40
Town & Country	01-03	23	SQ2	1-1/4	36296	0	GP	36071	300/3,500		30
		30	RT3	2	75119	0			350/3,500	500/5,000	30
		50	SQ3	2	37136				500/5,000	600/6,000	40
Town & Country Except w/Stow & Go Seats	04-07	23	SQ2	1-1/4	36296	0	GP	36071	300/3,500		30
		30	RT3	2	75119	0			350/3,500	500/5,000	30
		50	SQ3	2	37136				500/5,000	600/6,000	40
Town & Country w/Stow & Go Seats	05-07	45	SQ2	1-1/4	36320	0	HM	36071	300/3,500		25
		54	SQ3	2	75305	0			350/3,500	400/4,000	25
Town & Country	08-10	24	SQ2	1-1/4	36455	0	GP,JR	36061	300/3,500		20
		19	SQ3	2	75579	0	GP,JR		400/4,000	500/5,000	20
Town & Country	11-16	24	SQ2	1-1/4	36455	0	GP,JR	36061	300/3,500		20
		19	SQ3	2	75579	0	GP,JR		400/4,000	500/5,000	20
Voyager	01-03	23	SQ2	1-1/4	36296	0	GP	36071	300/3,500		30
		30	RT3	2	75119	0			350/3,500	500/5,000	30
		50	SQ3	2	37136				500/5,000	600/6,000	40
DODGE											
Avenger	08-10	28	SQ1	1-1/4	24871	0	GP,JR	3594	200/2,000		15
		30	SQ2	1-1/4	36448		GP,JR	36065	300/3,500		30
Avenger	11	28	SQ1	1-1/4	24871	0	GP,JR	3594	200/2,000		15
Avenger	12-14	28	SQ1	1-1/4	24871	0	GP,JR	3594	200/2,000		15
Caliber	07	23	SQ1	1-1/4	24769	0	GP	3591	200/2,000		15
Caliber Except SRT-4	08-12	23	SQ1	1-1/4	24769	0	GP	3591	200/2,000		15
Caravan	96-00	23	SQ2	1-1/4	36296	0	GP	36071	300/3,500		30
		30	RT3	2	75119				350/3,500	500/5,000	30
		50	SQ3	2	37136				500/5,000	600/6,000	40
Caravan	01-03	23	SQ2	1-1/4	36296	0	GP	36071	300/3,500		30
		30	RT3	2	75119	0			350/3,500	500/5,000	30
		50	SQ3	2	37136				500/5,000	600/6,000	40
Caravan Except w/Stow & Go Seats	04-07	23	SQ2	1-1/4	36296	0	GP	36071	300/3,500		30
		30	RT3	2	75119	0			350/3,500	500/5,000	30
		50	SQ3	2	37136				500/5,000	600/6,000	40
Challenger Except Models w/Quad Tip Exhaust	08-14	25	SQ2	1-1/4	36548	0	HM	36061	300/3,500		30
		23	SQ3	2	76145	0	HM		675/4,500		30
Challenger Except Models w/Quad Tip Exhaust	15-19	25	SQ2	1-1/4	36548	0	HM	36061	300/3,500		30
		23	SQ3	2	76145	0	HM		675/4,500		30
Charger	06-10	25	SQ2	1-1/4	36548	0	HM	36061	300/3,500		30
		23	SQ3	2	76145	0	HM		675/4,500		30
Charger	11-14	25	SQ2	1-1/4	36548	0	HM	36061	300/3,500		30
		23	SQ3	2	76145	0	HM		675/4,500		30
Charger	15-19	25	SQ2	1-1/4	36548	0	HM	36061	300/3,500		30
		23	SQ3	2	76145	0	HM		675/4,500		30

GP Hitch cross-tube concealed behind bumper.
 HM Hitch cross-tube is visible beneath bumper.

JR Exhaust must be temporarily lowered for installation.

T-ONE						TOW HARNESS						4-FLAT WIRING				REQ. 4 FLAT WIRING		7-WAY HARDWARE	BRAKE CONTROL HARNESS	IN
PC	T-ONE	FN	IN	AMP	CP	PC	TOW HARN	FN	IN	AMP	CP	TYPE	ELEC	POS	CHOICE 1	CHOICE 2	6-WAY ADAPTER			
CHRYSLER (Continued)																				
E19	118462	BN,CH	45	2.1,4.2	X								B	SUV1.2	119130	119178				
E19	118462	BN,CH	45	2.1,4.2	X								B,E	SUV1.2	119191	119148	20320	20321		
													B,E	SUV1.2	119191	119148				
													B	PC3.4	119130	119178				
													B	PC3.4	119130	119178				
E19	118444	BN,CH	45	2.1,4.2	X								B,E	PC3.4	119191	119148				
E19	118444	BN,CH	45	2.1,4.2	X								B,E	PC3.4	119191	119148				
E11	118334	HG	20	2.1,5									B	SUV1.2	119130	119178	20320	20321	20224	
E8	118376	HG	15	2.1,5									B	SUV1.2	119130	119178	20320	20321	20224	
E7	118300		20	7.5									A	SUV1.2	119148	20252	20320	20321	20224	
E7	118300		20	7.5									A	SUV1.2	119148	20252	20320	20321	20224	
E18	118552	CH	45	4.2,7.5	X								A,E	SUV1.2	119191	119148	20320	20321	20224	
E18	118534	BN,CH	45	4.2,7.5	X								C,E	SUV1.2	119191	119148	20320	20321	20224	
E8	118376	HG	15	2.1,5									B	SUV1.2	119130	119178	20320	20321	20224	
DODGE																				
E19	118445	BN,CH	45	2.1,4.2	X								A,E	PC1.2	119191	119148				
E18	118550	BN,CH	45	2.1,5,6	X								B,E	PC1.2	119191	119148				
E17	118577	CH	45	2.1,5,6	X								N	PC1.2		119251				
E18	118428	BN,CH	45	2.1,4.2	X								B,E	PC1.2	119191	119148				
E18	118552	CH	45	4.2,7.5	X								A,E	PC1.2	119191	119148	20320	20321	20224	
E11	118334	HG	20	2.1,5									B	SUV1.2	119130	119178	20320	20321	20224	
E8	118376	HG	15	2.1,5									B	SUV1.2	119130	119178	20320	20321	20224	
E7	118300		20	7.5									A	SUV1.2	119148	20252	20320	20321	20224	
E7	118404		10	7.5									A	PC3.4	119148	20252				
E16	118656	CH	45	4.2,7.5	X								A,E	PC3.4	119191	119148				
E7	118404		10	7.5									A	PC3.4	119148	20252				
E19	118560	CH	25	4.2,7.5	X								N	PC3.4		119251				
E15	118655	CH	45	4.2,7.5	X								A,E	PC3.4	119191	119148				

A 2 wire system.
B 3 wire system. Converter required.
BN Exterior mounted plug on some or all models. May require an aftermarket electrical mounting box or bracket. (Sold separately)
C 2 or 3 wire system determine at installation.

CH T-One is equipped with circuit protected ModuLite® module.
E ModuLite® required.
HG T-One incorporates taillight converter.
N DO NOT cut or splice vehicle wiring. Only use approved T-One or see auto dealer for trailer tow wiring kit.

RT3 Round Tube Class III 2"
SQ1 Square Tube Class I
SQ2 Square Tube Class II
SQ3 Square Tube Class III

MODEL / STYLE	YEAR	TRAILER HITCHES									
		PC	REC TYPE	REC SIZE	PART NO.	NO DRILL	FOOTNOTES	OPTIONAL DRAWBAR	WC (LBS.)	WD (LBS.)	IN
DODGE (Continued)											
Dakota	97-99	50	SQ3	2	37136		CT,GU		500/5,000	600/6,000	35
		34	SQ3	2	75038		GU,GP		500/5,000	800/8,000	30
		31	SQ3	2	75073	0	GU,GP		500/5,000	750/7,500	15
Dakota	00-01	50	SQ3	2	37136		CT,GU		500/5,000	600/6,000	35
		34	SQ3	2	75038		GU,GP		500/5,000	800/8,000	30
		31	SQ3	2	75073	0	GU,GP		500/5,000	750/7,500	15
Dakota w/Factory 7-Way	00-09										
Dakota	02-03	34	SQ3	2	75038		GU,GP		500/5,000	800/8,000	30
		31	SQ3	2	75073	0	GU,GP		500/5,000	750/7,500	15
Dakota Except Quad Cab	02-03	50	SQ3	2	37136		CT,GU		500/5,000	600/6,000	35
Dakota	04	34	SQ3	2	75038		GU,GP		500/5,000	800/8,000	30
		31	SQ3	2	75073	0	GU,GP		500/5,000	750/7,500	15
Dakota Except Quad Cab	04	50	SQ3	2	37136		CT,GU		500/5,000	600/6,000	35
Dakota	05-09	27	SQ3	2	75251	0	HM		500/5,000	800/8,000	20
Dakota	10	27	SQ3	2	75251	0	HM		500/5,000	800/8,000	20
Dart	13-16	30	SQ1	1-1/4	24890	0	HM	3592	200/2,000		20
Durango	98-99	34	SQ3	2	75081	0	GP		500/5,000	750/7,500	15
Durango	00-03	34	SQ3	2	75081	0	GP		500/5,000	750/7,500	15
Durango w/Factory 7-Way	00-08										
Durango	04-06	18	SQ4	2	75162		AI		600/6,000	900/9,000	50
		39	RT4	2	75292	0			600/6,000	900/9,000	20
Durango	07-08	18	SQ4	2	75162		AI		600/6,000	900/9,000	50
Durango	09	18	SQ4	2	75162		AI		600/6,000	900/9,000	50
Durango w/Factory 7-Way	09										
Durango	11-13	25	RT4	2	75713	0	CS,HM		900/6,000	900/7,500	20
		31	SQ4	2	76196	0	DU,GP,JR,TZ		900/6,000	900/7,500	90
Durango	14-19	25	RT4	2	75713	0	CS,HM		900/6,000	900/7,500	20
		31	SQ4	2	76196	0	DU,GP,JR,TZ		900/6,000	900/7,500	90
Grand Caravan	96-00	23	SQ2	1-1/4	36296	0	GP	36071	300/3,500		30
		30	RT3	2	75119				350/3,500	500/5,000	30
		50	SQ3	2	37136				500/5,000	600/6,000	40
Grand Caravan	01-03	23	SQ2	1-1/4	36296	0	GP	36071	300/3,500		30
		30	RT3	2	75119	0			350/3,500	500/5,000	30
		50	SQ3	2	37136				500/5,000	600/6,000	40
Grand Caravan Except w/Stow & Go Seats	04-07	23	SQ2	1-1/4	36296	0	GP	36071	300/3,500		30
		30	RT3	2	75119	0			350/3,500	500/5,000	30
		50	SQ3	2	37136				500/5,000	600/6,000	40
Grand Caravan w/Stow & Go Seats	05-07	45	SQ2	1-1/4	36320	0	HM	36071	300/3,500		25
		54	SQ3	2	75305	0			350/3,500	400/4,000	25
Grand Caravan	08-10	24	SQ2	1-1/4	36455	0	GP,JR	36061	300/3,500		20
		19	SQ3	2	75579	0	GP,JR		400/4,000	500/5,000	20
Grand Caravan	11-19	24	SQ2	1-1/4	36455	0	GP,JR	36061	300/3,500		20
		19	SQ3	2	75579	0	GP,JR		400/4,000	500/5,000	20
Intrepid	93-97	43	SQ2	1-1/4	36170†		JR,TA,HM	36061	300/3,500		40
Intrepid	98-04	37	SQ2	1-1/4	36268†		JR,HM	36053	300/3,500		30
Journey	09	29	RT3	2	75648	0	HM,JR		400/4,000	400/4,000	25
		33	SQ3	2	76225	0	DU,FE,GP,JR,TZ		525/3,500		90
Journey	10	29	RT3	2	75648	0	HM,JR		400/4,000	400/4,000	25
		33	SQ3	2	76225	0	DU,FE,GP,JR,TZ		525/3,500		90
Journey w/LED Taillights	11-19	29	RT3	2	75648	0	HM,JR		400/4,000	400/4,000	25
		33	SQ3	2	76225	0	DU,FE,GP,JR,TZ		525/3,500		90
Journey Except w/LED Taillights	12-19	29	RT3	2	75648	0	HM,JR		400/4,000	400/4,000	25
		33	SQ3	2	76225	0	DU,FE,GP,JR,TZ		525/3,500		90

AI Additional installation time may be required.

CS Will fit with full-size spare tire stowed under vehicle.

CT Will not fit long bed models after 1999.

DU Fascia removal required.

FE Fascia trimming may be required. Allow additional installation time.

GP Hitch crosstube concealed behind bumper.

GU Will not fit vehicles with factory or aftermarket lower Fascia/Rolpan or Tube Bumper.

HM Hitch crosstube is visible beneath bumper.

JR Exhaust must be temporarily lowered for installation.

TA Trunk access required for hitch installation.

TZ Requires replacement of the impact structure with hitch.

T-ONE						TOW HARNESS					4-FLAT WIRING				REQ. 4 FLAT WIRING		7-WAY HARDWIRE	BRAKE CONTROL HARNESS	IN		
PC	T-ONE	FN	IN	AMP	CP	PC	TOW HARN	FN	IN	AMP	CP	TYPE	ELEC	POS	CHOICE 1	CHOICE 2				6-WAY ADAPTER	7-WAY ADAPTER
DODGE (Continued)																					
E7	118329	BN,HJ	5	7.5									A	PU3,4	119148	20252	20320	20321	20224	3020-P	5
E7	118329	BN,HJ	5	7.5		E3	118381	BN,RD	5	7.5		4-Flat	A	PU3,4	119148	20252	20320	20321	20224	3020-P	5
							20135	RD	10			Both	A	PU3	119148	20252					
E7	118329	BN,HJ	5	7.5		E3	118381	BN,RD	5	7.5		4-Flat	A	PU3,4	119148	20252	20320	20321	20224	3020-P	5
E7	118329	BN,HJ	5	7.5		E3	118381	BN,RD	5	7.5		4-Flat	A	PU3,4	119148	20252	20320	20321	20224	3020-P	5
E7	118323	BN,HJ	10	7.5		E3	118381	BN,RD	5	7.5		4-Flat	A	PU1,2	119148	20252	20320	20321	20224	3020-P	5
E7	118323	BN,HJ	10	7.5		E3	118381	BN,RD	5	7.5		4-Flat	A	PU1,2	119148	20252	20320	20321	20224	3020-P	5
E7	118323	BN,HJ	10	7.5									A	PU1,2	119148	20252	20320	20321	20224	3020-P	5
E16	118568		25	4.2,7.5	X								A,E	PC3,4	119191	119148					
E11	118334	BN,HG	20	2.1,5									B	SUV1,2	119130	119178	20320	20321	20224	3020-P	5
E11	118334	BN,HG	20	2.1,5		E3	118381	BN,RD	5	7.5		4-Flat	B	SUV1,2	119130	119178	20320	20321	20224	3020-P	5
							20135	RD	10			Both	H	SUV6	119148	20252					
E15	118390	BN,CH	45	2.1,5,6	X	E3	118381	BN,RD	5	7.5		4-Flat	B,E	SUV1,2	119191	119148	20320	20321	20224	3020-P	5
E15	118390	BN,CH	45	2.1,5,6	X	E3	118381	BN,RD	5	7.5		4-Flat	B,E	SUV1,2	119191	119148	20320	20321	20224	3020-P	5
E15	118390	BN,CH	45	2.1,5,6	X	E8	118384	BN,RD	5	7.5		4-Flat	B,E	SUV1,2	119191	119148	20320	20321	20224	3020-P	5
							74682	RD	10			Both	H	SUV6	119148	20252					
E18	118552	CH	45	4.2,7,5	X								A,E	SUV1,2	119191	119148	20320	20321	20224	3045-P	5
E16	118617	CH,BN	45	4.2,7,5	X								A,E	SUV1,2	119191	119148	20320	20321	20224	3045-P	5
E11	118334	HG	20	2.1,5									B	SUV1,2	119130	119178	20320	20321	20224		
E8	118376	HG	15	2.1,5									B	SUV1,2	119130	119178	20320	20321	20224		
E7	118300		20	7.5									A	SUV1,2	119148	20252	20320	20321	20224		
E7	118300		20	7.5									A	SUV1,2	119148	20252	20320	20321	20224		
E18	118552	CH	45	4.2,7,5	X								A,E	SUV1,2	119191	119148	20320	20321	20224		
E18	118534	BN,CH	45	4.2,7,5	X								C,E	SUV1,2	119191	119148	20320	20321	20224		
													B	PC3,4	119130	119178					
E12	118364	BN,HG	15	2.1,5									B	PC1,2	119130	119178					
E18	118474	CH	45	2.1,5,6	X								B,E	SUV1,2	119191	119148	20320	20321	20224		
E8	118495		10	7.5									A	SUV1,2	119148	20252	20320	20321	20224		
E17	118536	CH	45	4.2,7,5	X								BM	SUV1,2	119251	119191	20320	20321	20224		
E14	118567	CH	45	2.1,5,6	X								A,E	SUV1,2	119191	119148	20320	20321	20224		

A 2 wire system.
B 3 wire system. Converter required.
BM Multiplexed wiring system. ModuLite® HD Plus or Ultra required.
BN Exterior mounted plug on some or all models. May require an aftermarket electrical mounting box or bracket. (Sold separately)
C 2 or 3 wire system determine at installation.
CH T-One is equipped with circuit protected ModuLite® module.

E ModuLite® required.
H 3 wire system with OEM standard 2 wire harness.
HG T-One incorporates taillight converter.
HJ Per Dodge owner's manual: If trailer is equipped with more than standard lighting (1 taillight per side) use of ModuLite® or dealer supplied harness is required.
RD For vehicles equipped with factory tow package may require additional components or may be used as a replacement harness.

RT3 Round Tube Class III 2"
RT4 Round Tube Class IV 2"
SQ1 Square Tube Class I
SQ2 Square Tube Class II
SQ3 Square Tube Class III
SQ4 Square Tube Class IV

MODEL / STYLE	YEAR	TRAILER HITCHES									
		PC	REC TYPE	REC SIZE	PART NO.	NO DRILL	FOOTNOTES	OPTIONAL DRAWBAR	WC (LBS.)	WD (LBS.)	IN
DODGE (Continued)											
Magnum	05-08	25	SQ2	1-1/4	36548	0	HM	36061	300/3,500		30
		23	SQ3	2	76145	0	HM		675/4,500		30
Neon	00-05	42	SQ1	1-1/4	24701†		GP,JR	3593	200/2,000		20
Nitro	07	29	SQ3	2	75517	0	GP		500/5,000	600/6,000	20
Nitro	08-11	29	SQ3	2	75517	0	GP		500/5,000	600/6,000	20
Ram w/Factory 7-Way	00-01										
Ram 1500	95-01	49	RT3	2	37133		GU		500/5,000	750/7,500	40
		23	SQ3	2	75101	0			500/5,000	800/8,000	15
		37	SQ4	2	40050		CQ,GO,GX		600/6,000	1,000/10,000	40
		53	SQ4	2	41536	0			600/6,000	1,000/10,000	15
		54	RT4	2	37130		GU		700/7,000	1,200/12,000	40
		45	SQ5	2	41923	0	@,GP		1,200/12,000	1,400/14,000	35
Ram 1500 w/Deep Drop Bumper	95-01	34	SQ3	2	41504		CQ		500/5,000	1,000/10,000	40
Ram 1500 (Built Before 11/2002)	02-03	14	SQ3	2	75135	0	CP,DS,GU		500/5,000	1,000/10,000	15
Ram 1500 (Built Before 11/2002), w/Factory 7-Way	02-03										
Ram 1500 (Built After 11/2002)	03	11	SQ3	2	75151	0	CP,DS,GU		500/5,000	800/8,000	20
		46	SQ4	2	75420	0	CP,DY		600/6,000	1,000/10,000	25
		11	SQ4	2	75662	0	CP,DS		600/6,000	1,000/10,000	20
		37	SQ5	2	41929		@,DY,GP,KL,SG		1,200/12,000	1,500/15,000	35
		63	SQ5	2-1/2	45518		#,DY,KL,SB		1,200/12,000	1,700/14,000	35
Ram 1500 (Built After 11/2002) w/Factory 7-Way	03										
Ram 1500 Except Daytona/Hemi Sport Quad Cab/Ram Rumble Bee/SRT-10	04-05	11	SQ3	2	75151	0	CP,GU		500/5,000	800/8,000	20
		46	SQ4	2	75420	0	CP		600/6,000	1,000/10,000	25
		11	SQ4	2	75662	0	CP		600/6,000	1,000/10,000	20
		37	SQ5	2	41929		@,GP,KL,SG		1,200/12,000	1,500/15,000	35
		63	SQ5	2-1/2	45518		#,KL,SB		1,200/12,000	1,700/14,000	35
Ram 1500 Except Daytona/Hemi Sport Quad Cab/Ram Rumble Bee/SRT-10, w/Factory 7-Way	04-05										
Ram 1500	06-08	11	SQ3	2	75151	0	CP,GU		500/5,000	800/8,000	20
		46	SQ4	2	75420	0	CP		600/6,000	1,000/10,000	25
		11	SQ4	2	75662	0	CP		600/6,000	1,000/10,000	20
		37	SQ5	2	41929		@,GP,KL,SG		1,200/12,000	1,500/15,000	35
		63	SQ5	2-1/2	45518		#,KL,SB		1,200/12,000	1,700/14,000	35
Ram 1500 Except Mega Cab/SRT-10, w/Factory 7-Way	06-08										
Ram 1500	09	11	SQ4	2	75662	0	CP		600/6,000	1,000/10,000	20
Ram 1500 w/Factory 7-Way	09-10										
Ram 1500	10	11	SQ4	2	75662	0	CP		600/6,000	1,000/10,000	20
Ram 2500	95-98	47	SQ5	2-1/2	45505		#,HX		1,200/12,000	1,700/14,000	45
Ram 2500	95-02	49	RT3	2	37133		GU		500/5,000	750/7,500	40
		23	SQ3	2	75101	0			500/5,000	800/8,000	15
		37	SQ4	2	40050		CQ,GO,GX		600/6,000	1,000/10,000	40
		53	SQ4	2	41536	0			600/6,000	1,000/10,000	15
		54	RT4	2	37130		GU		700/7,000	1,200/12,000	40
		45	SQ5	2	41923	0	@,GP		1,200/12,000	1,400/14,000	35
Ram 2500 w/Deep Drop Bumper	95-02	34	SQ3	2	41504		CQ		500/5,000	1,000/10,000	40
Ram 2500	99-02	54	SQ5	2-1/2	45513		#		1,200/12,000	1,700/14,000	30
Ram 2500 w/Factory 7-Way	02-09										

Titan hitches require use of a 2-1/2" shank Titan ball mount.

@ Ultra Frame ball mount must be used to achieve maximum weight carrying rating.

CP Fits all models without factory installed receiver.

CQ Will not fit with heavy duty suspension.

DS Use DT #75151 On 1500 Models Built After 11/1/02. Use DT #75135 On 1500 Models Built Before 11/1/02.

DY Use On 1500 Models Built After 11/1/02.

GO Requires hitch with packaging date code 2/15/94 or later.

GP Hitch cross-tube concealed behind bumper.

GU Will not fit vehicles with factory or aftermarket lower Fascia/Rolipan or Tube Bumper.

GX Requires fabrication of L-bracket to reposition exhaust on 1995 and later 6 ft. box models.

HM Hitch cross-tube is visible beneath bumper.

HX Minor exhaust modification may be required.

JR Exhaust must be temporarily lowered for installation.

KL Hitch is designed to attach beneath the OEM hitch.

SB Will not fit models with short bed.

SG Hitches produced before 09/10/07 are rated at 1000/10000 WC & 1200/12000 WD.

T-ONE						TOW HARNESS						4-FLAT WIRING				REQ. 4 FLAT WIRING		7-WAY HARDWIRE	BRAKE CONTROL HARNESS	IN	
PC	T-ONE	FN	IN	AMP	CP	PC	TOW HARN	FN	IN	AMP	CP	TYPE	ELEC	POS	CHOICE 1	CHOICE 2	6-WAY ADAPTER				7-WAY ADAPTER
DODGE (Continued)																					
E19	118402	BN,CH	45	2.1,5.6	X								B,E	PC1,2	119191	119148					
													A	PC3,4	119148	20252					
E19	118554	BN,CH	45	4.2,7.5	X								B	SUV1,2	119130	119178	20320	20321	20224		
E19	118554	BN,CH	45	4.2,7.5	X								B,E	SUV1,2	119191	119148	20320	20321	20224		
							20135	RD	10			Both	H	PU3	119148	20252					
E7	118329	BN,HJ	5	7.5									A	PU3,4	119148	20252	20320	20321	20224	3020-P	5
													A	PU3	119148	20252	20320	20321	20224	3020-P	5
						E3	118381	BN,RD	5	7.5		4-Flat	A	PU3	119148	20252	20320	20321	20224	3020-P	5
							20135	RD	10			Both	H	PU3	119148	20252					
						E3	118381	BN,RD	5	7.5		4-Flat	A	PU3	119148	20252	20320	20321	20224	3020-P	5
							20135	RD	10			Both	H	PU3	119148	20252					
						E3	118381	BN,RD	5	7.5		4-Flat	A	PU3	119148	20252	20320	20321	20224	3020-P	5
							20135	RD	10			Both	H	PU3	119148	20252					
						E8	118384	BN,RD	5	7.5		4-Flat	A	PU3	119148	20252	20320	20321	20224	3020-P	5
							74682	RD	10			Both	A	PU3	119148	20252					
							85219	RD	5			7-Way									
						E8	118384	BN,RD	5	7.5		4-Flat	A	PU3	119148	20252	20320	20321	20224	3021-P	5
E7	118329	BN,HJ	5	7.5									A	PU3,4	119148	20252	20320	20321	20224	3020-P	5
E7	118329	BN,HJ	5	7.5									A	PU3,4	119148	20252	20320	20321	20224	3020-P	5
													A	PU3,4	119148	20252	20320	20321	20224	3020-P	5
E7	118329	BN,HJ	5	7.5									A	PU3,4	119148	20252	20320	20321	20224	3020-P	5
E7	118329	BN,HJ	5	7.5									A	PU3,4	119148	20252	20320	20321	20224	3020-P	5
							20135	RD	10			Both	H	PU3	119148	20252					

A 2 wire system.
B 3 wire system. Converter required.
BN Exterior mounted plug on some or all models. May require an aftermarket electrical mounting box or bracket. (Sold separately)
CH T-One is equipped with circuit protected ModuLite® module.
E ModuLite® required.
H 3 wire system with OEM standard 2 wire harness.
HJ Per Dodge owner's manual: If trailer is equipped with more than standard lighting (1 taillight per side) use of ModuLite® or dealer supplied harness is required.
RD For vehicles equipped with factory tow package may require additional components or may be used as a replacement harness.

RT3 Round Tube Class III 2"
RT4 Round Tube Class IV 2"
SQ1 Square Tube Class I
SQ2 Square Tube Class II
SQ3 Square Tube Class III
SQ4 Square Tube Class IV
SQ5 Square Tube Class V

DODGE

RECEIVER HITCHES

MODEL / STYLE	YEAR	TRAILER HITCHES									
		PC	REC TYPE	REC SIZE	PART NO.	NO DRILL	FOOTNOTES	OPTIONAL DRAWBAR	WC (LBS.)	WD (LBS.)	IN
DODGE (Continued)											
Ram 2500	03-05	11	SQ3	2	75151	0	CP,GU		500/5,000	800/8,000	20
		46	SQ4	2	75420	0	CP,DY		600/6,000	1,000/10,000	25
		11	SQ4	2	75662	0	CP		600/6,000	1,000/10,000	20
		37	SQ5	2	41929		@,GP,KL,SG		1,200/12,000	1,500/15,000	35
		63	SQ5	2-1/2	45518		#,KL,SB		1,200/12,000	1,700/14,000	35
		66	SQ5	2-1/2	45509		#,AA,GH,HM,LT,SO,TO		2,000/18,000	2,500/18,000	95
Ram 2500	06-09	11	SQ3	2	75151	0	CP,GU		500/5,000	800/8,000	20
		46	SQ4	2	75420	0	CP		600/6,000	1,000/10,000	25
		11	SQ4	2	75662	0	CP		600/6,000	1,000/10,000	20
		37	SQ5	2	41929		@,GP,KL,SG		1,200/12,000	1,500/15,000	35
		66	SQ5	2-1/2	45509		#,AA,GH,HM,LT,SO,TO		2,000/18,000	2,500/18,000	95
		63	SQ5	2-1/2	45518		#,KL,SB		1,200/12,000	1,700/14,000	35
Ram 2500 Except Mega Cab	06-09	63	SQ5	2-1/2	45518		#,KL,SB		1,200/12,000	1,700/14,000	35
Ram 2500	10	37	SQ5	2	41929		@,GP,KL,SG		1,200/12,000	1,500/15,000	35
		66	SQ5	2-1/2	45509		#,AA,GH,HM,LT,SO,TO		2,000/18,000	2,500/18,000	95
Ram 2500 Except Mega Cab	10	63	SQ5	2-1/2	45518		#,KL,SB		1,200/12,000	1,700/14,000	35
Ram 2500 w/Factory 7-Way	10										
Ram 3500	95-98	47	SQ5	2-1/2	45505		#,HX		1,200/12,000	1,700/14,000	45
Ram 3500	95-02	49	RT3	2	37133		GU		500/5,000	750/7,500	40
		23	SQ3	2	75101	0			500/5,000	800/8,000	15
		37	SQ4	2	40050		CQ,GO,GX		600/6,000	1,000/10,000	40
		53	SQ4	2	41536	0			600/6,000	1,000/10,000	15
		54	RT4	2	37130		GU		700/7,000	1,200/12,000	40
		45	SQ5	2	41923	0	@,GP		1,200/12,000	1,400/14,000	35
Ram 3500 w/Deep Drop Bumper	95-02	34	SQ3	2	41504		CQ		500/5,000	1,000/10,000	40
Ram 3500	99-02	54	SQ5	2-1/2	45513		#		1,200/12,000	1,700/14,000	30
Ram 3500 w/Factory 7-Way	02-09										
Ram 3500	03-05	11	SQ3	2	75151	0	CP,GU		500/5,000	800/8,000	20
		46	SQ4	2	75420	0	CP,DY		600/6,000	1,000/10,000	25
		11	SQ4	2	75662	0	CP		600/6,000	1,000/10,000	20
		37	SQ5	2	41929		@,GP,KL,SG		1,200/12,000	1,500/15,000	35
		63	SQ5	2-1/2	45518		#,KL,SB		1,200/12,000	1,700/14,000	35
		66	SQ5	2-1/2	45509		#,AA,GH,HM,LT,SO,TO		2,000/18,000	2,500/18,000	95
Ram 3500	06-09	11	SQ3	2	75151	0	CP,GU		500/5,000	800/8,000	20
		46	SQ4	2	75420	0	CP		600/6,000	1,000/10,000	25
		11	SQ4	2	75662	0	CP		600/6,000	1,000/10,000	20
		37	SQ5	2	41929		@,GP,KL,SG		1,200/12,000	1,500/15,000	35
		66	SQ5	2-1/2	45509		#,AA,GH,HM,LT,SO,TO		2,000/18,000	2,500/18,000	95
		63	SQ5	2-1/2	45518		#,KL,SB		1,200/12,000	1,700/14,000	35
Ram 3500 Except Mega Cab	06-09	63	SQ5	2-1/2	45518		#,KL,SB		1,200/12,000	1,700/14,000	35
Ram 3500 Cab & Chassis, w/34" Wide Frames	07-10	29	SQ5	2	41936		@		1,200/12,000		30
		55	SQ5	2	41947		@		1,600/15,000	1,600/16,000	35
Ram 3500	10	37	SQ5	2	41929		@,GP,KL,SG		1,200/12,000	1,500/15,000	35
		66	SQ5	2-1/2	45509		#,AA,GH,HM,LT,SO,TO		2,000/18,000	2,500/18,000	95
Ram 3500 Except Mega Cab	10	63	SQ5	2-1/2	45518		#,KL,SB		1,200/12,000	1,700/14,000	35
Ram 3500 w/Factory 7-Way	10										
Ram 4500 Cab & Chassis, w/34" Wide Frames	08-10	29	SQ5	2	41936		@		1,200/12,000		30
		55	SQ5	2	41947		@		1,600/15,000	1,600/16,000	35
Ram 5500 Cab & Chassis, w/34" Wide Frames	08-10	29	SQ5	2	41936		@		1,200/12,000		30
		55	SQ5	2	41947		@		1,600/15,000	1,600/16,000	35
Sprinter 2500 w/41" Wide Frames, Except 118" Wheelbase & Factory Metal Step Platform	03-06	48	SQ3	2	75210	0	HM		500/5,000	750/7,500	20

Titan hitches require use of a 2-1/2" shank Titan ball mount.

@ Ultra Frame ball mount must be used to achieve maximum weight carrying rating.

AA Requires temporary removal of bumper during installation.

CP Fits all models without factory installed receiver.

CQ Will not fit with heavy duty suspension.

DY Use On 1500 Models Built After 11/1/02.

GH Will not fit models with 34 in. wide frames.

GO Requires hitch with packaging date code 2/15/94 or later.

GP Hitch crosstube concealed behind bumper.

GU Will not fit vehicles with factory or aftermarket lower Fascia/Rollpan or Tube Bumper.

GX Requires fabrication of L-bracket to reposition exhaust on 1995 and later 6 ft. box models.

HM Hitch crosstube is visible beneath bumper.

HX Minor exhaust modification may be required.

KL Hitch is designed to attach beneath the OEM hitch.

LT Requires removal of factory hitch if equipped.

SB Will not fit models with short bed.

SG Hitches produced before 09/10/07 are rated at 1000/10000 WC & 1200/12000 WD.

SD With this hitch installed the step bumper is no longer able to be used as a towing point.

TO Will not fit models equipped Chassis Cab spring mount.

T-ONE					TOW HARNESS					4-FLAT WIRING				REQ. 4 FLAT WIRING		7-WAY HARDWARE	BRAKE CONTROL HARNESS	IN			
PC	T-ONE	FN	IN	AMP	CP	PC	TOW HARN	FN	IN	AMP	CP	TYPE	ELEC	POS	CHOICE 1				CHOICE 2	6-WAY ADAPTER	7-WAY ADAPTER
DODGE (Continued)																					
						E3	118381	BN,RD	5	7.5		4-Flat	A	PU3	119148	20252	20320	20321	20224	3020-P	5
						E3	118381	BN,RD	5	7.5		4-Flat	A	PU3	119148	20252	20320	20321	20224	3020-P	5
						E3	118381	BN,RD	5	7.5		4-Flat	A	PU3	119148	20252	20320	20321	20224	3020-P	5
						E8	118384	BN,RD	5	7.5		4-Flat	A	PU3	119148	20252	20320	20321	20224	3021-P	5
						E8	118384	BN,RD	5	7.5		4-Flat	A	PU3	119148	20252	20320	20321	20224	3021-P	5
							74682	RD	10			Both	A	PU3	119148	20252					
							85219	RD	5			7-Way	A	PU3	119148	20252					
E7	118329	BN,HJ	5	7.5									A	PU3,4	119148	20252	20320	20321	20224	3020-P	5
E7	118329	BN,HJ	5	7.5									A	PU3,4	119148	20252	20320	20321	20224	3020-P	5
E7	118329	BN,HJ	5	7.5									A	PU3,4	119148	20252	20320	20321	20224	3020-P	5
E7	118329	BN,HJ	5	7.5									A	PU3,4	119148	20252	20320	20321	20224	3020-P	5
							20135	RD	10			Both	H	PU3	119148	20252					
						E3	118381	BN,RD	5	7.5		4-Flat	A	PU3	119148	20252	20320	20321	20224	3020-P	5
						E3	118381	BN,RD	5	7.5		4-Flat	A	PU3	119148	20252	20320	20321	20224	3020-P	5
						E3	118381	BN,RD	5	7.5		4-Flat	A	PU3	119148	20252	20320	20321	20224	3020-P	5
						E3	118381	BN,RD	5	7.5		4-Flat	A	PU3	119148	20252	20320	20321	20224	3020-P	5
						E3	118381	BN,RD	5	7.5		4-Flat	A	PU3	119148	20252	20320	20321	20224	3020-P	5
						E3	118381	BN,RD	5	7.5		4-Flat	A	PU3	119148	20252	20320	20321	20224	3020-P	5
						E3	118381	BN,RD	5	7.5		4-Flat	A	PU3	119148	20252	20320	20321	20224	3020-P	5
						E3	118381	BN,RD	5	7.5		4-Flat	A	PU3	119148	20252	20320	20321	20224	3020-P	5
						E3	118381	BN,RD	5	7.5		4-Flat	A	PU3	119148	20252	20320	20321	20224	3020-P	5
						E3	118381	BN,RD	5	7.5		4-Flat	A	PU3	119148	20252	20320	20321	20224	3020-P	5
						E3	118381	BN,RD	5	7.5		4-Flat	B,E	SUV3,4	119191	119148	20320	20321	20224		

A 2 wire system.
B 3 wire system. Converter required.
BN Exterior mounted plug on some or all models. May require an aftermarket electrical mounting box or bracket. (Sold separately)
C 2 or 3 wire system determine at installation.

E ModuLite® required.
H 3 wire system with OEM standard 2 wire harness.
HJ Per Dodge owner's manual: If trailer is equipped with more than standard lighting (1 taillight per side) use of ModuLite® or dealer supplied harness is required.
RD For vehicles equipped with factory tow package may require additional components or may be used as a replacement harness.

RT3 Round Tube Class III 2"
RT4 Round Tube Class IV 2"
SQ3 Square Tube Class III
SQ4 Square Tube Class IV
SQ5 Square Tube Class V

MODEL / STYLE	YEAR	TRAILER HITCHES									
		PC	REC TYPE	REC SIZE	PART NO.	NO DRILL	FOOTNOTES	OPTIONAL DRAWBAR	WC (LBS.)	WD (LBS.)	IN
DODGE (Continued)											
Sprinter 2500 w/41" Wide Frames, Except 118" Wheelbase & Factory Metal Step Platform, w/Factory 7-Way	03-06										
Sprinter 2500 144" & 170" Wheelbase, Except w/Factory Step Bumper	07-09	53	SQ4	2	75549	0	HM,UL		600/6,000	750/7,500	20
Sprinter 2500 144" & 170" Wheelbase, Except w/Factory Step Bumper, w/Factory 7-Way	07-09										
Sprinter 2500 w/Factory Step Bumper Excluding Models w/30-3/8" Frame Width	07-09	52	SQ3	2	75601	0	HM		500/5,000	750/7,500	30
Sprinter 2500 w/Factory Step Bumper, w/Factory 7-Way	07-09										
Sprinter 3500 w/41" Wide Frames, Except 118" Wheelbase & Factory Metal Step Platform	03-06	48	SQ3	2	75210	0	HM		500/5,000	750/7,500	20
Sprinter 3500 w/41" Wide Frames, Except 118" Wheelbase & Factory Metal Step Platform, w/Factory 7-Way	03-06										
Sprinter 3500 144" & 170" Wheelbase, Except w/Factory Step Bumper	07-09	53	SQ4	2	75549	0	HM,UL		600/6,000	750/7,500	20
Sprinter 3500 144" & 170" Wheelbase, Except w/Factory Step Bumper, w/Factory 7-Way	07-09										
Sprinter 3500 w/Factory Step Bumper Excluding Models w/30-3/8" Frame Width	07-09	52	SQ3	2	75601	0	HM		500/5,000	750/7,500	30
Sprinter 3500 w/Factory Step Bumper, w/Factory 7-Way	07-09										
Stratus 4 Dr.	95-06	40	SQ2	1-1/4	36301		JR,HM	36061	300/3,500		60
Van, B1500	95-97	30	SQ3	2	75140	0	DH		500/5,000	1,000/10,000	30
Van, B1500 Except w/Factory Step Bumper	95-97	41	SQ3	2	75090	0	DH		500/5,000	750/7,500	20
		35	SQ4	2	41533	0	DH		600/6,000	1,000/10,000	20
Van, B1500	98	30	SQ3	2	75140	0			500/5,000	1,000/10,000	30
Van, B1500 Except w/Factory Step Bumper	98	41	SQ3	2	75090	0	BF		500/5,000	750/7,500	20
		35	SQ4	2	41533	0	BF		600/6,000	1,000/10,000	20
Van, B2500	95-97	30	SQ3	2	75140	0	DH		500/5,000	1,000/10,000	30
Van, B2500 Except w/Factory Step Bumper	95-97	41	SQ3	2	75090	0	DH		500/5,000	750/7,500	20
		35	SQ4	2	41533	0	DH		600/6,000	1,000/10,000	20
Van, B2500	98	30	SQ3	2	75140	0			500/5,000	1,000/10,000	30
Van, B2500 Except w/Factory Step Bumper	98	41	SQ3	2	75090	0	BF		500/5,000	750/7,500	20
		35	SQ4	2	41533	0	BF		600/6,000	1,000/10,000	20
Van, B3500	95-97	30	SQ3	2	75140	0	DH		500/5,000	1,000/10,000	30
Van, B3500 Except w/Factory Step Bumper	95-97	41	SQ3	2	75090	0	DH		500/5,000	750/7,500	20
		35	SQ4	2	41533	0	DH		600/6,000	1,000/10,000	20
Van, B3500	98	30	SQ3	2	75140	0			500/5,000	1,000/10,000	30
Van, B3500 Except w/Factory Step Bumper	98	41	SQ3	2	75090	0	BF		500/5,000	750/7,500	20
		35	SQ4	2	41533	0	BF		600/6,000	1,000/10,000	20
Van, Ram 1500	99-00	30	SQ3	2	75140	0			500/5,000	1,000/10,000	30
Van, Ram 1500 Except w/Factory Step Bumper	99-00	41	SQ3	2	75090	0	BF		500/5,000	750/7,500	20
		35	SQ4	2	41533	0	BF		600/6,000	1,000/10,000	20
Van, Ram 1500	01-03	30	SQ3	2	75140	0			500/5,000	1,000/10,000	30
Van, Ram 1500 Except w/Factory Step Bumper	01-03	41	SQ3	2	75090	0	BF		500/5,000	750/7,500	20
		35	SQ4	2	41533	0	BF		600/6,000	1,000/10,000	20
Van, Ram 1500 w/Factory 7-Way	01-03										
Van, Ram 2500	99-00	30	SQ3	2	75140	0			500/5,000	1,000/10,000	30
Van, Ram 2500 Except w/Factory Step Bumper	99-00	41	SQ3	2	75090	0	BF		500/5,000	750/7,500	20
		35	SQ4	2	41533	0	BF		600/6,000	1,000/10,000	20
Van, Ram 2500	01-03	30	SQ3	2	75140	0			500/5,000	1,000/10,000	30
Van, Ram 2500 Except w/Factory Step Bumper	01-03	41	SQ3	2	75090	0	BF		500/5,000	750/7,500	20
		35	SQ4	2	41533	0	BF		600/6,000	1,000/10,000	20
Van, Ram 2500 w/Factory 7-Way	01-03										

BF Requires standard bumper. Will not fit with step bumper.

DH Cannot be installed on 1987-97 vehicles with factory step bumpers unless step bumper and its mounting brackets are permanently removed and standard factory bumper is installed.

HM Hitch cross-tube is visible beneath bumper.

JR Exhaust must be temporarily lowered for installation.

UL This hitch will not fit a Sprinter single or dual rear-wheel vehicle with a 30-3/8 in. wide frame measured outside of frame to outside of frame.

T-ONE						TOW HARNESS						4-FLAT WIRING				REQ. 4 FLAT WIRING		7-WAY HARDWARE	BRAKE CONTROL HARNESS	IN	
PC	T-ONE	FN	IN	AMP	CP	PC	TOW HARN	FN	IN	AMP	CP	TYPE	ELEC	POS	CHOICE 1	CHOICE 2	6-WAY ADAPTER				7-WAY ADAPTER
DODGE (Continued)																					
							20135	RD	10			Both	H	SUV6							
E17	118650	CH	45	5,7.5	X	E3	118381	BN,RD	5	7.5		4-Flat	B,E	SUV1,2	119191	119148	20320	20321	20224	3063-P	10
							20135	RD	10			Both	H	SUV6	119148	20252					
E17	118650	CH	45	5,7.5	X	E3	118381	BN,RD	5	7.5		4-Flat	B,E	SUV1,2	119191	119148	20320	20321	20224	3063-P	10
							20135	RD	10			Both	H	SUV6	119148	20252					
						E3	118381	BN,RD	5	7.5		4-Flat	B,E	SUV3,4	119191	119148	20320	20321	20224		
							20135	RD	10			Both	H	SUV6	119148	20252					
E17	118650	CH	45	5,7.5	X	E3	118381	BN,RD	5	7.5		4-Flat	B,E	SUV1,2	119191	119148	20320	20321	20224		
							20135	RD	10			Both	H	SUV6	119148	20252					
E17	118650	CH	45	5,7.5	X	E3	118381	BN,RD	5	7.5		4-Flat	B,E	SUV1,2	119191	119148	20320	20321	20224		
							20135	RD	10			Both	H	SUV6	119148	20252					
													B	PC3,4	119130	119178					
E1	118328	BN	5	7.5									A	SUV7	119148	20252	20320	20321	20224		
E1	118328	BN	5	7.5									A	SUV7	119148	20252	20320	20321	20224		
E1	118328	BN	5	7.5									A	SUV7	119148	20252	20320	20321	20224		
E1	118328	BN	5	7.5									A	SUV7	119148	20252	20320	20321	20224		
E1	118328	BN	5	7.5									A	SUV7	119148	20252	20320	20321	20224		
E1	118328	BN	5	7.5									A	SUV7	119148	20252	20320	20321	20224		
E1	118328	BN	5	7.5									A	SUV7	119148	20252	20320	20321	20224		
E1	118328	BN	5	7.5									A	SUV7	119148	20252	20320	20321	20224		
E1	118328	BN	5	7.5									A	SUV7	119148	20252	20320	20321	20224		
E1	118328	BN	5	7.5									A	SUV7	119148	20252	20320	20321	20224		
E1	118328	BN	5	7.5									A	SUV7	119148	20252	20320	20321	20224		
E1	118328	BN	5	7.5									A	SUV7	119148	20252	20320	20321	20224		
E1	118328	BN	5	7.5									A	SUV7	119148	20252	20320	20321	20224		
E1	118328	BN	5	7.5									A	SUV7	119148	20252	20320	20321	20224		
E1	118328	BN	5	7.5									A	SUV7	119148	20252	20320	20321	20224		
E1	118368	BN	5	7.5									A	SUV5	119148	20252	20320	20321	20224		
E1	118368	BN	5	7.5									A	SUV5	119148	20252	20320	20321	20224		
E3	118381	BN	5	7.5									A	SUV5	119148	20252	20320	20321	20224		
E3	118381	BN	5	7.5									A	SUV5	119148	20252	20320	20321	20224		
							20135	RD	10			Both	A	SUV5	119148	20252					
E1	118368	BN	5	7.5									A	SUV5	119148	20252	20320	20321	20224		
E1	118368	BN	5	7.5									A	SUV5	119148	20252	20320	20321	20224		
E3	118381	BN	5	7.5									A	SUV5	119148	20252	20320	20321	20224		
E3	118381	BN	5	7.5									A	SUV5	119148	20252	20320	20321	20224		
							20135	RD	10			Both	A	SUV5	119148	20252					

- A** 2 wire system.
- B** 3 wire system. Converter required.
- BN** Exterior mounted plug on some or all models. May require an aftermarket electrical mounting box or bracket. (Sold separately)
- CH** T-One is equipped with circuit protected ModuLite® module.
- E** ModuLite® required.
- H** 3 wire system with OEM standard 2 wire harness.
- RD** For vehicles equipped with factory tow package may require additional components or may be used as a replacement harness.

- SQ2** Square Tube Class II
- SQ3** Square Tube Class III
- SQ4** Square Tube Class IV

DODGE

RECEIVER HITCHES

MODEL / STYLE	YEAR	TRAILER HITCHES									
		PC	REC TYPE	REC SIZE	PART NO.	NO DRILL	FOOTNOTES	OPTIONAL DRAWBAR	WC (LBS.)	WD (LBS.)	IN
DODGE (Continued)											
Van, Ram 3500	99-00	30	SQ3	2	75140	0			500/5,000	1,000/10,000	30
Van, Ram 3500 Except w/Factory Step Bumper	99-00	41	SQ3	2	75090	0	BF		500/5,000	750/7,500	20
		35	SQ4	2	41533	0	BF		600/6,000	1,000/10,000	20
Van, Ram 3500	01-03	30	SQ3	2	75140	0			500/5,000	1,000/10,000	30
Van, Ram 3500 Except w/Factory Step Bumper	01-03	41	SQ3	2	75090	0	BF		500/5,000	750/7,500	20
		35	SQ4	2	41533	0	BF		600/6,000	1,000/10,000	20
Van, Ram 3500 w/Factory 7-Way	01-03										
EAGLE											
Vision	93-97	43	SQ2	1-1/4	361701		JR,TA,HM	36061	300/3,500		40
FIAT											
500 Except Abarth	12-19	28	SQ1	1-1/4	24873	0	GP,JR	3593	200/2,000		30
500L	14-17	28	SQ1	1-1/4	24969		EP,SV	3593	200/2,000		45
500L	18	28	SQ1	1-1/4	24969		EP,SV	3593	200/2,000		45
500X	16-19	26	RT3	2	76019		HM		675/4,500		30
FORD											
Aerostar Extended Body	97	50	SQ3	2	37136				500/5,000	600/6,000	40
Aerostar Standard Body	97										40
C-MAX	13-18	29	SQ1	1-1/4	24896		GP,JR,KH	3593	200/2,000		25
Crown Victoria	92-97	36	SQ1	1-1/4	245261		CA,GP	3592	200/2,000		25
		39	SQ2	1-1/4	36116		CA,GP	36063	300/3,500		30
		38	SQ3	2	41116		CA,GP		350/3,500	750/6,000	30
Crown Victoria	98-09	36	SQ1	1-1/4	245261		CA,GP	3592	200/2,000		25
		39	SQ2	1-1/4	36116		CA,GP	36063	300/3,500		30
		38	SQ3	2	41116		CA,GP		350/3,500	750/6,000	30
E-150 Econoline	95-02	19	RT4	2	75703		CS,HM		600/6,000	1,000/10,000	20
		37	SQ5	2	41906		@,HM,HY		1,000/10,000	1,200/12,000	30
E-150 Econoline w/Factory 7-Way	97-02										
E-150 Econoline	00-02	35	SQ5	2	41926	0	@,HM		1,000/10,000	1,200/12,000	30
		41	SQ5	2	41945	0	@,HM		1,500/10,000	1,200/12,000	30
E-150 Econoline	03-07	19	RT4	2	75703		CS,HM		600/6,000	1,000/10,000	20
		37	SQ5	2	41906		@,HM,HY		1,000/10,000	1,200/12,000	30
		35	SQ5	2	41926	0	@,HM		1,000/10,000	1,200/12,000	30
		41	SQ5	2	41945	0	@,HM		1,500/10,000	1,200/12,000	30
E-150 Econoline w/Factory 7-Way	04-09										
E-150 Econoline	08	19	RT4	2	75703		CS,HM		600/6,000	1,000/10,000	20
		37	SQ5	2	41906		@,HM,HY		1,000/10,000	1,200/12,000	30
		35	SQ5	2	41926	0	@,HM		1,000/10,000	1,200/12,000	30
		41	SQ5	2	41945	0	@,HM		1,500/10,000	1,200/12,000	30
E-150 Econoline	09-14	19	RT4	2	75703	0	CS,HM		600/6,000	1,000/10,000	20
		37	SQ5	2	41906		@,HM,HY		1,000/10,000	1,200/12,000	30
		35	SQ5	2	41926	0	@,HM		1,000/10,000	1,200/12,000	30
		41	SQ5	2	41945	0	@,HM		1,500/10,000	1,200/12,000	30
E-150 Econoline w/Factory 4-Flat (Prepped Class I Towing Package)	09-12										
E-150 Econoline w/Factory 7-Way (Prepped Class II Towing Package)	09-12										
E-250 Econoline	95-02	19	RT4	2	75703		CS,HM		600/6,000	1,000/10,000	20
		37	SQ5	2	41906		@,HM,HY		1,000/10,000	1,200/12,000	30
E-250 Econoline w/Factory 7-Way	97-09										

@ Ultra Frame ball mount must be used to achieve maximum weight carrying rating.
 BF Requires standard bumper. Will not fit with step bumper.
 CA Models with dual exhaust require exhaust modification.
 CS Will fit with full-size spare tire stowed under vehicle.
 EP Fascia trimming may be required.
 GP Hitch crosstube concealed behind bumper.

HM Hitch crosstube is visible beneath bumper.
 HY Ultra Frame ball mount DT #4283/HH #80125 cannot be used in rise position on vehicles with step bumpers.
 JR Exhaust must be temporarily lowered for installation.
 KH Minor heat shield modification may be required.
 SV Trimming or removal of under body appearance panel may be required.
 TA Trunk access required for hitch installation.

T-ONE						TOW HARNESS						4-FLAT WIRING				REQ. 4 FLAT WIRING		7-WAY HARDWARE	BRAKE CONTROL HARNESS	IN
PC	T-ONE	FN	IN	AMP	CP	PC	TOW HARN	FN	IN	AMP	CP	TYPE	ELEC	POS	CHOICE 1	CHOICE 2	6-WAY ADAPTER			
DODGE (Continued)																				
E1	118368	BN	5	7.5									A	SUV5	119148	20252	20320	20321	20224	
E1	118368	BN	5	7.5									A	SUV5	119148	20252	20320	20321	20224	
E3	118381	BN	5	7.5									A	SUV5	119148	20252	20320	20321	20224	
E3	118381	BN	5	7.5									A	SUV5	119148	20252	20320	20321	20224	
						20135	RD	10				Both	A	SUV5	119148	20252				
EAGLE																				
													B	PC3,4	119130	119178				
FIAT																				
E20	118546	CH	45	4.2,7.5	X								B,E	PC1,2	119191	119148				
E17	118772	CH	45	5.7.5	X								B,E	PC3,4	119191	119148				
													B,E	PC3,4	119191	119148				
E24	118693	CH	45	4.2,7.5	X								BT	SUV1.2	119251	119191				
FORD																				
E5	118344	BN	10	7.5									A	SUV1.2	119148	20252	20320	20321	20224	
E5	118344	BN	10	7.5									A	SUV1.2	119148	20252	20320	20321	20224	
													BM	PC1,2	119251	119191				
E9	118326		20	7.5									A,E	PC3,4	119191	119148	20320	20321	20224	
													B,E	PC3,4	119191	119148	20320	20321	20224	
E5	118344	BN	10	7.5									A	SUV1.2	119148	20252	20320	20321	20224	3035-P 5
						74682	RD	10				Both	A	SUV6	119148	20252				
						85219	RD	5				7-Way	A	SUV6	119148	20252				
E5	118344	BN	10	7.5									A	SUV1.2	119148	20252	20320	20321	20224	3035-P 5
													A	SUV1.2	119148	20252	20320	20321	20224	3035-P 5
						85219	RD	5				7-Way	A	SUV6	119148	20252				
						74682	RD	10				Both	A	SUV6	119148	20252				
E17	118551	CH	45	4.2,7.5	X								A,E	SUV1.2	119191	119148	20320	20321	20224	3035-P 5
E17	118551	CH	45	4.2,7.5	X								A,E	SUV1.2	119191	119148	20320	20321	20224	3034-P 20
						E3	118260	BN	10	7.5		4-Flat	A	SUV6	119148	20252				
						E14	118261	BN	10			7-Way	A	SUV6	119148	20252				
E5	118344	BN	10	7.5									A	SUV1.2	119148	20252	20320	20321	20224	3035-P 5
						85219	RD	5				7-Way	A	SUV6	119148	20252				
						74682	RD	10				Both	A	SUV6	119148	20252				

A 2 wire system.
B 3 wire system. Converter required.
BM Multiplexed wiring system. ModuLite® HD Plus or Ultra required.
BN Exterior mounted plug on some or all models. May require an aftermarket electrical mounting box or bracket. (Sold separately)
BT Shared Brake/Tail multiplexed wiring system. ModuLite® HD Plus or Ultra required.
CH T-One is equipped with circuit protected ModuLite® module.
E ModuLite® required.
RD For vehicles equipped with factory tow package may require additional components or may be used as a replacement harness.

RT3 Round Tube Class III 2"
RT4 Round Tube Class IV 2"
SQ1 Square Tube Class I
SQ2 Square Tube Class II
SQ3 Square Tube Class III
SQ4 Square Tube Class IV
SQ5 Square Tube Class V

RECEIVER HITCH APPLICATION GUIDE

FORD

MODEL / STYLE	YEAR	TRAILER HITCHES									
		PC	REC TYPE	REC SIZE	PART NO.	NO DRILL	FOOTNOTES	OPTIONAL DRAWBAR	WC (LBS.)	WD (LBS.)	IN
FORD (Continued)											
E-250 Econoline	00-02	35	SQ5	2	41926	0	@,HM		1,000/10,000	1,200/12,000	30
		41	SQ5	2	41945	0	@,HM		1,500/10,000	1,200/12,000	30
E-250 Econoline	03-07	19	RT4	2	75703		CS,HM		600/6,000	1,000/10,000	20
		37	SQ5	2	41906		@,HM,HY		1,000/10,000	1,200/12,000	30
		35	SQ5	2	41926	0	@,HM		1,000/10,000	1,200/12,000	30
		41	SQ5	2	41945	0	@,HM		1,500/10,000	1,200/12,000	30
E-250 Econoline	08	19	RT4	2	75703		CS,HM		600/6,000	1,000/10,000	20
		37	SQ5	2	41906		@,HM,HY		1,000/10,000	1,200/12,000	30
		35	SQ5	2	41926	0	@,HM		1,000/10,000	1,200/12,000	30
		41	SQ5	2	41945	0	@,HM		1,500/10,000	1,200/12,000	30
E-250 Econoline	09-14	19	RT4	2	75703		CS,HM		600/6,000	1,000/10,000	20
		37	SQ5	2	41906		@,HM,HY		1,000/10,000	1,200/12,000	30
		35	SQ5	2	41926	0	@,HM		1,000/10,000	1,200/12,000	30
		41	SQ5	2	41945	0	@,HM		1,500/10,000	1,200/12,000	30
E-250 Econoline w/Factory 4-Flat (Prepped Class I Towing Package)	09-12										
E-250 Econoline w/Factory 7-Way (Prepped Class II Towing Package)	09-12										
E-350 Econoline	95-02	19	RT4	2	75703		CS,HM		600/6,000	1,000/10,000	20
		37	SQ5	2	41906		@,HM,HY		1,000/10,000	1,200/12,000	30
E-350 Econoline w/Factory 7-Way	97-02										
E-350 Econoline	00-02	35	SQ5	2	41926	0	@,HM		1,000/10,000	1,200/12,000	30
		41	SQ5	2	41945	0	@,HM		1,500/10,000	1,200/12,000	30
E-350 Econoline Super Duty	03-07	19	RT4	2	75703		CS,HM		600/6,000	1,000/10,000	20
		37	SQ5	2	41906		@,HM,HY		1,000/10,000	1,200/12,000	30
		35	SQ5	2	41926	0	@,HM		1,000/10,000	1,200/12,000	30
		41	SQ5	2	41945	0	@,HM		1,500/10,000	1,200/12,000	30
E-350 Econoline Super Duty w/Factory 7-Way	03-09										
E-350 Econoline Super Duty	08	19	RT4	2	75703		CS,HM		600/6,000	1,000/10,000	20
		37	SQ5	2	41906		@,HM,HY		1,000/10,000	1,200/12,000	30
		35	SQ5	2	41926	0	@,HM		1,000/10,000	1,200/12,000	30
		41	SQ5	2	41945	0	@,HM		1,500/10,000	1,200/12,000	30
E-350 Econoline Super Duty	09-14	19	RT4	2	75703		CS,HM		600/6,000	1,000/10,000	20
		37	SQ5	2	41906		@,HM,HY		1,000/10,000	1,200/12,000	30
		35	SQ5	2	41926	0	@,HM		1,000/10,000	1,200/12,000	30
		41	SQ5	2	41945	0	@,HM		1,500/10,000	1,200/12,000	30
E-350 Econoline Super Duty w/Factory 7-Way (Prepped Class II Towing Package)	09-12										
EcoSport	18	27	SQ2	1-1/4	36660	0	JR,GP,SV	36071	350/3,500		45
Edge Except Sport	07-10	33	SQ2	1-1/4	36447	0	GP,JR,KH	36051	300/3,500		45
		20	SQ3	2	75992		GP,KH,JR		400/4,000	400/4,000	55
Edge Sport	09-10	37	SQ3	2	75686	0	GP,JR,KH		350/3,500		45
Edge Except Sport	11-14	20	SQ3	2	75992		GP,KH,JR		400/4,000	400/4,000	55
Edge Sport	11-14	35	SQ3	2	75728	0	GP,JR,KH		525/3,500	525/4,000	45
Edge Except Sport & Titanium Models	15-18	28	RT3	2	75214	0	JR,HM,SV,TW		600/4,000	600/4,000	30
		35	SQ3	2	75234	0	GP,TA,SV,JR,TW		675/4,500	675/4,500	45
Edge Titanium and Sport Models Only	15-18	35	SQ3	2	75234	0	GP,TA,SV,JR,TW		675/4,500	675/4,500	45
Edge Titanium Model Only	15	28	RT3	2	75214	0	JR,HM,SV,TW		600/4,000	600/4,000	30
Edge Except Titanium Models	19	28	RT3	2	75214	0	JR,HM,SV,TW		600/4,000	600/4,000	30
		35	SQ3	2	75234	0	JR,HM,SV,TW		675/4,500	675/4,500	30
Edge Titanium Mode Only	19										

@ Ultra Frame ball mount must be used to achieve maximum weight carrying rating.
 CS Will fit with full-size spare tire stowed under vehicle.
 GP Hitch cross-tube concealed behind bumper.
 HM Hitch cross-tube is visible beneath bumper.
 HY Ultra Frame ball mount DT #4283/HH #80125 cannot be used in rise position on vehicles with step bumpers.

JR Exhaust must be temporarily lowered for installation.
 KH Minor heat shield modification may be required.
 SV Trimming or removal of under body appearance panel may be required.
 TA Trunk access required for hitch installation.
 TW Receiver hitch may limit hands-free liftgate sensor range

RECEIVER HITCHES

T-ONE					TOW HARNESS					4-FLAT WIRING				REQ. 4 FLAT WIRING		7-WAY HARDWIRE	BRAKE CONTROL HARNESS	IN			
PC	T-ONE	FN	IN	AMP	CP	PC	TOW HARN	FN	IN	AMP	CP	TYPE	ELEC	POS	CHOICE 1				CHOICE 2	6-WAY ADAPTER	7-WAY ADAPTER
FORD (Continued)																					
E5	118344	BN	10	7.5									A	SUV1,2	119148	20252	20320	20321	20224	3035-P	5
													A	SUV1,2	119148	20252	20320	20321	20224	3035-P	5
E17	118551	CH	45	4.2,7.5	X								A,E	SUV1,2	119191	119148	20320	20321	20224	3035-P	5
E17	118551	CH	45	4.2,7.5	X								A,E	SUV1,2	119191	119148	20320	20321	20224	3034-P	20
						E3	118260	BN	10	7.5		4-Flat	A	SUV6	119148	20252					
						E14	118261	BN	10			7-Way	A	SUV6	119148	20252					
E5	118344	BN	10	7.5									A	SUV1,2	119148	20252	20320	20321	20224	3035-P	5
							74682 85219	RD RD	10 5			Both 7-Way	A	SUV6	119148	20252					
E5	118344	BN	10	7.5									A	SUV1,2	119148	20252	20320	20321	20224	3035-P	5
													A	SUV1,2	119148	20252	20320	20321	20224	3035-P	5
							74682 85219	RD RD	10 5			Both 7-Way	A	SUV6	119148	20252					
E17	118551	CH	45	4.2,7.5	X								A,E	SUV1,2	119191	119148	20320	20321	20224	3035-P	5
E17	118551	CH	45	4.2,7.5	X								A,E	SUV1,2	119191	119148	20320	20321	20224	3034-P	20
						E3	118260	BN	10	7.5		4-Flat	A	SUV6	119148	20252					
						E14	118261	BN	10			7-Way									
E17	118551	CH	45	4.2,7.5	X								N	SUV1,2		119251	20320	20321			
E17	118551	CH	45	4.2,7.5	X								N	SUV1,2		119251	20320	20321			
E21	118515	CH	45	4.2,7.5	X								N	SUV1,2		119251	20320	20321			
E21	118515	CH	45	4.2,7.5	X								N	SUV1,2		119251	20320	20321			
E16	118669	CH,BN	45	4.2,7.5	X								A,E	PC1,2	119191	119148					
		CH,BN												SUV1,2	119191	119148					
E14	118677	CH,BN	45	4.2,7.5	X								B,E	SUV1,2	119191	119148					
E20	118805	CH,BN	45	5.7.5	X								B,E	SUV1,2							
E19	118806	CH,BN	45	5.7.5	X								B,E	SUV1,2							

A 2 wire system.
B 3 wire system. Converter required.
BN Exterior mounted plug on some or all models. May require an aftermarket electrical mounting box or bracket. (Sold separately)
CH T-One is equipped with circuit protected ModuLite® module.

E ModuLite® required.
N DO NOT cut or splice vehicle wiring. Only use approved T-One or see auto dealer for trailer tow wiring kit.
RD For vehicles equipped with factory tow package may require additional components or may be used as a replacement harness.

RT3 Round Tube Class III 2"
RT4 Round Tube Class IV 2"
SQ2 Square Tube Class II
SQ3 Square Tube Class III
SQ5 Square Tube Class V

RECEIVER HITCH APPLICATION GUIDE

MODEL / STYLE	YEAR	TRAILER HITCHES									
		PC	REC TYPE	REC SIZE	PART NO.	NO DRILL	FOOTNOTES	OPTIONAL DRAWBAR	WC (LBS.)	WD (LBS.)	IN
FORD (Continued)											
Escape	01-03	36	RT3	2	75118	0	HM,KH		350/3,500	500/5,000	35
		50	SQ3	2	37136		KH		500/5,000	600/6,000	60
Escape	04	36	RT3	2	75118	0	HM		350/3,500	500/5,000	35
		50	SQ3	2	37136				500/5,000	600/6,000	60
Escape	05-07	22	SQ2	1-1/4	36501		HM	36051	300/3,500		20
		34	RT3	2	75751	0	HM		675/4,500	675/5,250	25
Escape	08-12	22	SQ2	1-1/4	36501		HM	36051	300/3,500		20
		34	RT3	2	75751	0	HM		675/4,500	675/5,250	25
Escape	13-16	38	SQ2	1-1/4	36524	0	HM	36071	300/3,500		15
		38	SQ2	1-1/4	36529	0	GP,JR,KH	36071	300/3,500		20
		43	SQ3	2	75782	0	GP,JR,KH		525/3,500	525/5,000	60
		40	RT3	2	75758	0	HM		675/4,500	675/5,000	15
Escape	17-18	38	SQ2	1-1/4	36524	0	HM	36071	300/3,500		15
		38	SQ2	1-1/4	36529	0	GP,JR,KH	36071	300/3,500		60
		43	SQ3	2	75782	0	GP,JR,KH		525/3,500	525/5,000	60
		40	RT3	2	75758	0	HM		675/4,500	675/5,000	15
Escape	19	38	SQ2	1-1/4	36524	0	HM	36071	300/3,500		15
		38	SQ2	1-1/4	36529	0	GP,JR,KH	36071	300/3,500		60
		43	SQ3	2	75782	0	GP,JR,KH		525/3,500	525/5,000	60
		40	RT3	2	75758	0	HM		675/4,500	675/5,000	15
Excursion	00-03										
Excursion w/Factory 7-Way	00-05										
Expedition	97-02	42	SQ3	2	75071	0	GP		500/5,000	800/8,000	15
		41	SQ4	2	41527	0	GP		600/6,000	1,000/10,000	15
Expedition w/Factory 7-Way	97-11										
Expedition	03										
Expedition	13										
Expedition	15-17										
Explorer	95-00	32	SQ2	1-1/4	36246	0	HM	36051	300/3,500		15
		34	RT3	2	75083	0	JF,HM		500/5,000	600/6,000	15
		31	SQ3	2	75096	0	HM		500/5,000	750/7,500	15
Explorer w/Factory 7-Way	00-05										
Explorer 2 Dr. Sport	01-03	32	SQ2	1-1/4	36246	0	HM	36051	300/3,500		15
		34	RT3	2	75083	0	JF,HM		500/5,000	600/6,000	15
		31	SQ3	2	75096	0	HM		500/5,000	750/7,500	15
Explorer 4 Dr.	01	32	SQ2	1-1/4	36246	0	HM	36051	300/3,500		15
		34	RT3	2	75083	0	JF,HM		500/5,000	600/6,000	15
		31	SQ3	2	75096	0	HM		500/5,000	750/7,500	15
Explorer 4 Dr.	02-03	47	RT3	2	75132	0	HM,KL		500/5,000	800/8,000	20
Explorer 4 Dr.	04-05	47	RT3	2	75132	0	HM,KL		500/5,000	800/8,000	20
Explorer w/1-1/4" Receivers	06-10	39	RT3	2	75437	0	HM,KL		500/5,000	800/8,000	25
Explorer w/Factory 7-Way	06-14										
Explorer	11-19	19	SQ3	2	76034	0	HM,JR,LTW		675/4,500	500/5,000	45
Explorer	20	22	SQ2	1-1/4	36787	0	JR,KH,GP,X,SV		300/3,500		40
		28	SQ3	2	76320	0	JR,KH,GP,X,SV		900/6,000		
Explorer Sport Trac	01	32	RT3	2	75112	0	CS		500/5,000	600/6,000	15
Explorer Sport Trac	02-03	32	RT3	2	75112	0	CS		500/5,000	600/6,000	15
Explorer Sport Trac	04-05	32	RT3	2	75112	0	CS		500/5,000	600/6,000	15

CS Will fit with full-size spare tire stowed under vehicle.
GP Hitch cross-tube concealed behind bumper.
HM Hitch cross-tube is visible beneath bumper.
JF Will not fit with 16 in. spare tire.
JR Exhaust must be temporarily lowered for installation.
KH Minor heat shield modification may be required.

KL Hitch is designed to attach beneath the OEM hitch.
L Exhaust repositioning required.
SV Trimming or removal of under body appearance panel may be required.
TW Receiver hitch may limit hands-free liftgate sensor range
X Minor fascia trimming required.

T-ONE					TOW HARNESS							4-FLAT WIRING				REQ. 4 FLAT WIRING		7-WAY HARDWIRE	BRAKE CONTROL HARNESS	IN	
PC	T-ONE	FN	IN	AMP	CP	PC	TOW HARN	FN	IN	AMP	CP	TYPE	ELEC	POS	CHOICE 1	CHOICE 2	6-WAY ADAPTER				7-WAY ADAPTER
FORD (Continued)																					
E11	118343	HG,RW	10	2.1,5									B	SUV1,2	119130	119178	20320	20321	20224		
													B,E	SUV1,2	119191	119148	20320	20321	20224		
E17	118426	BN,CH	45	2.1,4.2	X								B,E	SUV1,2	119191	119148	20320	20321	20224		
E17	118551	CH	45	4.2,7.5	X	E1	118251	BN,QP,RD	5	7.5		4-Flat	A	SUV1,2	119148	20252	20320	20321	20224		
E18	118566	BN,CH	45	4.2,7.5	X								B,E	SUV1,2	119191	119148	20320	20321	20224		
E17	118715	CH	45	4.2,7.5	X								B,E	SUV1,2	119191	119148					
E17	118802	CH,BN	45	5.7,5	X								A,E	SUV1,2	119191	119148					
E5	118344	BN	10	7.5									A	SUV1,2	119148	20252					
							85219	RD	5			7-Way	A	SUV6	119148	20252				3035-P	5
							74682	RD	10			Both									
E5	118344	BN	10	7.5									A	SUV1,2	119148	20252	20320	20321	20224	3035-P	5
							74682	RD	10			Both	A	SUV6	119148	20252					
							85219	RD	5			7-Way									
						E5	118344	BN	10	7.5		4-Flat	A	SUV1,2	119148	20252					
													A	PU5					20224	3034-P	20
													A	PU5						3036-P	20
E16	118345	BN,CH	45	2.1,4.2		E3	118241	BN,RD	5	7.5		4-Flat	B,E	SUV1,2	119191	119148	20320	20321	20224		
							74682	RD	10			Both	A	SUV6	119148	20252					
							85219	RD	5			7-Way									
E5	118344	BN	10	7.5									A	SUV1,2	119148	20252	20320	20321	20224		
E16	118345	BN,CH	45	2.1,4.2		E3	118241	BN,RD	5	7.5		4-Flat	B,E	SUV1,2	119191	119148	20320	20321	20224		
E5	118344	BN	10	7.5									A	SUV1,2	119148	20252	20320	20321	20224	3035-P	5
													A	SUV1,2	119148	20252	20320	20321	20224	3035-P	5
							74682	RD	10			Both	A	SUV1,2	119130	119178	20320	20321	20224	3035-P	5
							85219	RD	5			7-Way	A	SUV6	119148	20252					
E11	118540	BN	5	7.5		E15	118272		20			7-Way	B,E	SUV3,4	119191	119148	20320	20321	20224	3035-P	5
E15	118599	CH	45	2.1,5.6	X								B,E	SUV3,4	119191	119148	20320	20321	20224		
													A	SUV1,2	119148	20252	20320	20321	20224		
E5	118344	BN	10	7.5									A	SUV1,2	119148	20252	20320	20321	20224		
													A	SUV1,2	119148	20252	20320	20321	20224		

A 2 wire system.
B 3 wire system. Converter required.
BN Exterior mounted plug on some or all models. May require an aftermarket electrical mounting box or bracket. (Sold separately)
CH T-One is equipped with circuit protected ModuLite® module.
CH.B
N

E ModuLite® required.
HG T-One incorporates taillight converter.
QP Will not fit vehicles with backup sensors built into rear bumper.
RD For vehicles equipped with factory tow package may require additional components or may be used as a replacement harness.
RW On some models it may require an upgraded flasher or ModuLite®.

RT3 Round Tube Class III 2"
SQ2 Square Tube Class II
SQ3 Square Tube Class III
SQ4 Square Tube Class IV

RECEIVER HITCH APPLICATION GUIDE

MODEL / STYLE	YEAR	TRAILER HITCHES									
		PC	REC TYPE	REC SIZE	PART NO.	NO DRILL	FOOTNOTES	OPTIONAL DRAWBAR	WC (LBS.)	WD (LBS.)	IN
FORD (Continued)											
Explorer Sport Trac w/Factory 7-Way	07-10										
F Super Duty Cab & Chassis, w/34" Wide Frames & 161" Wheelbase	89-97	37	SQ4	2	40050				600/6,000	1,000/10,000	40
F Super Duty Cab & Chassis, w/34" Wide Frames & 161" Wheelbase & w/Deep Drop Bumper	89-97	34	SQ3	2	41504		FP,K,M		500/5,000	1,000/10,000	40
F-150 Flareside	97-03	49	RT3	2	37133	0			500/5,000	750/7,500	25
		28	SQ3	2	75065	0	GP		500/5,000	800/8,000	30
		54	RT4	2	37130	0			700/7,000	1,200/12,000	25
		27	RT4	2	75740	0	FP,HM		900/6,000	1,000/10,000	20
		45	SQ5	2	41920	0	@,GP,SU		1,000/10,000	1,300/13,000	30
F-150 Styleside	97-03	49	RT3	2	37133	0			500/5,000	750/7,500	25
		28	SQ3	2	75065	0	GP		500/5,000	800/8,000	30
		54	RT4	2	37130	0			700/7,000	1,200/12,000	25
		27	RT4	2	75740	0	FP,HM		900/6,000	1,000/10,000	20
		45	SQ5	2	41920	0	@,GP,SU		1,000/10,000	1,300/13,000	30
F-150 w/Factory 7-Way	97-19										
F-150 SuperCrew	00-03	49	RT3	2	37133	0			500/5,000	750/7,500	25
		28	SQ3	2	75065	0	GP		500/5,000	800/8,000	30
		54	RT4	2	37130	0			700/7,000	1,200/12,000	25
		27	RT4	2	75740	0	FP,HM		900/6,000	1,000/10,000	20
		45	SQ5	2	41920	0	@,GP,SU		1,000/10,000	1,300/13,000	30
F-150 SuperCrew, w/Factory 7-Way	00-03										
F-150	04	49	RT3	2	37133		VB		500/5,000	750/7,500	45
		54	RT4	2	41549	0	HM,VB,KM		600/6,000	1,000/10,000	30
		50	RT4	2	75156	0	HM,VB,KM		600/6,000	800/8,000	30
F-150 SuperCrew, 5.5 ft. Bed, w/Factory 7-Way	04-05										
F-150	05	49	RT3	2	37133		VB		500/5,000	750/7,500	45
		54	RT4	2	41549	0	HM,VB,KM		600/6,000	1,000/10,000	30
		50	RT4	2	75156	0	HM,VB,KM		600/6,000	800/8,000	30
F-150	06-08	25	SQ4	2	75506	0	CP,HM		600/6,000	1,000/10,000	20
		40	SQ5	2	41933	0	@,CP,HM		1,200/12,000	1,400/14,000	20
F-150 SuperCrew, 5.5 & 6.5 ft. Beds, w/Factory 7-Way	06-19										
F-150	09-14	19	SQ4	2	75691	0	CP,GP		600/6,000	1,200/12,000	20
F-150	15-19	45	RT4	2	75216	0	HM,JL		900/6,000	1,200/12,000	30
		27	RT4	2	75938	0	HM,JL		900/6,000	800/8,000	30
		29	SQ4	2	76136	0	GP,FP		900/6,000	1,000/10,000	30
F-150 Heritage Flareside	04	49	RT3	2	37133	0			500/5,000	750/7,500	25
		28	SQ3	2	75065	0	GP		500/5,000	800/8,000	30
		54	RT4	2	37130	0			700/7,000	1,200/12,000	25
		27	RT4	2	75740	0	FP,HM		900/6,000	1,000/10,000	20
		45	SQ5	2	41920	0	@,GP,SU		1,000/10,000	1,300/13,000	30
F-150 Heritage Styleside	04	49	RT3	2	37133	0			500/5,000	750/7,500	25
		28	SQ3	2	75065	0	GP		500/5,000	800/8,000	30
		54	RT4	2	37130	0			700/7,000	1,200/12,000	25
		27	RT4	2	75740	0	FP,HM		900/6,000	1,000/10,000	20
		45	SQ5	2	41920	0	@,GP,SU		1,000/10,000	1,300/13,000	30
F-150 Heritage w/Factory 7-Way	04										

@ Ultra Frame ball mount must be used to achieve maximum weight carrying rating.
 CP Fits all models without factory installed receiver.
 FP Spare tire repositioning and/or modification of spare tire carrier may be required.
 GP Hitch crosstube concealed behind bumper.
 HM Hitch crosstube is visible beneath bumper.
 JL Installation requires OEM bumper and brackets.

K Adapter kit (#1685) required with DT #41504/HH #87480/RS #37081 & RS #44143 for 1980 and later F-Series pickups.
 KM Does not work with models originally equipped with OEM hitch.
 M Will fit with heavy-duty suspension.
 SU Hitches produced before 03/11/08 are rated at 1000/10000 WC & 1200/12000 WD.
 VB Will not fit vehicles with vibration damper installed at rear of frame on drivers side.

T-ONE					TOW HARNESS					4-FLAT WIRING				REQ. 4 FLAT WIRING		7-WAY HARDWARE	BRAKE CONTROL HARNESS	IN			
PC	T-ONE	FN	IN	AMP	CP	PC	TOW HARN	FN	IN	AMP	CP	TYPE	ELEC	POS	CHOICE 1				CHOICE 2	6-WAY ADAPTER	7-WAY ADAPTER
FORD (Continued)																					
							74682 85219	RD RD	10 5			Both 7-Way	A	SUV6	119148	20252				3035-P	5
													A	PU1,2	119148	20252	20320	20321	20224		
													A	PU1,2	119148	20252	20320	20321	20224		
E5	118344	BN	10	7.5		E19	118242	BN,RD	5			7-Way	A	PU1,2	119148	20252	20320	20321	20224	3035-P	5
						E19	118242	BN,RD	5			7-Way	A	PU1,2	119148	20252	20320	20321	20224	3035-P	5
							74682 85219	RD RD	10 5			Both 7-Way	A	PU3	119148	20252					
E5	118344	BN	10	7.5		E19	118242	BN,RD	5			7-Way	A	PU1,2	119148	20252	20320	20321	20224	3035-P	5
							74682 85219	RD RD	10 5			Both 7-Way	A	PU3	119148	20252					
						E19	118247	BN,RD	5			7-Way	A	PU3	119148	20252	20320	20321	20224	3035-P	5
							74682 85219	RD RD	10 5			Both 7-Way	A	PU3	119148	20252					
													A	PU3	119148	20252	20320	20321	20224	3035-P	5
													A	PU3	119148	20252	20320	20321	20224	3035-P	5
							85219 74682	RD RD	5 10			7-Way Both	A	PU3	119148	20252					
													A	PU3	119148	20252	20320	20321	20224	3036-P	20
						E15	118283	BN	5			7-Way	A	PU3	119148	20252	20320	20321	20224	3036-P	20
E5	118344	BN	10	7.5		E19	118242	BN,RD	5			7-Way	A	PU1,2	119148	20252	20320	20321	20224	3035-P	5
						E19	118242	BN,RD	5			7-Way	A	PU1,2	119148	20252	20320	20321	20224	3035-P	5
							74682 85219	RD RD	10 5			Both 7-Way	A	PU3	119148	20252					

A 2 wire system.

BN Exterior mounted plug on some or all models. May require an aftermarket electrical mounting box or bracket. (Sold separately)

RD For vehicles equipped with factory tow package may require additional components or may be used as a replacement harness.

RT3 Round Tube Class III 2"

RT4 Round Tube Class IV 2"

SQ3 Square Tube Class III

SQ4 Square Tube Class IV

SQ5 Square Tube Class V

RECEIVER HITCH APPLICATION GUIDE

MODEL / STYLE	YEAR	TRAILER HITCHES									
		PC	REC TYPE	REC SIZE	PART NO.	NO DRILL	FOOTNOTES	OPTIONAL DRAWBAR	WC (LBS.)	WD (LBS.)	IN
FORD (Continued)											
F-250 Heavy Duty	97	49	RT3	2	37133		GU		500/5,000	750/7,500	35
		34	SQ3	2	75038		GP		500/5,000	800/8,000	30
		37	SQ4	2	40050				600/6,000	1,000/10,000	40
		25	SQ4	2	41004		GP		600/6,000	1,000/10,000	30
		54	RT4	2	37130		GU		700/7,000	1,200/12,000	35
		42	SQ5	2	41904		@,GP,HD		1,000/10,000	1,200/12,000	30
		51	SQ5	2-1/2	45502		#,GU	1,200/12,000	1,700/14,000	45	
F-250 Heavy Duty, w/Deep Drop Bumper	97	34	SQ3	2	41504		FP,K,M		500/5,000	1,000/10,000	40
F-250 Styleside	97-99	49	RT3	2	37133	0			500/5,000	750/7,500	25
		28	SQ3	2	75065	0	GP		500/5,000	800/8,000	30
		54	RT4	2	37130	0			700/7,000	1,200/12,000	25
		27	RT4	2	75740	0	FP,HM		900/6,000	1,000/10,000	20
		45	SQ5	2	41920	0	@,GP,SU		1,000/10,000	1,300/13,000	30
F-250 Styleside, w/Factory 7-Way	97-99										
F-250 Super Duty Except Cab & Chassis	99-01	49	RT3	2	37133				500/5,000	750/7,500	30
		54	RT4	2	37130				700/7,000	1,200/12,000	30
		27	RT4	2	75740	0	FP,HM		900/6,000	1,000/10,000	20
		51	SQ5	2	41922	0	@,GP		1,000/10,000	1,200/12,000	15
		55	SQ5	2	41931	0	@,HM,SH		1,200/12,000	1,500/15,000	30
		60	SQ5	2-1/2	45508	0	#,CS,EF,HM,LT,M		2,000/18,000	2,500/18,000	50
F-250 Super Duty Except Cab & Chassis, w/Factory 7-Way	99-16										
F-250 Super Duty w/Deep Drop Bumper	99-01	70	SQ5	2-1/2	45514	0	#		1,200/12,000	1,700/14,000	20
F-250 Super Duty w/Deep Drop Bumper, w/Factory 7-Way	99-04										
F-250 Super Duty Except Cab & Chassis	02-04	49	RT3	2	37133				500/5,000	750/7,500	30
		54	RT4	2	37130				700/7,000	1,200/12,000	30
		27	RT4	2	75740	0	FP,HM		900/6,000	1,000/10,000	20
		51	SQ5	2	41922	0	@,GP		1,000/10,000	1,200/12,000	15
		55	SQ5	2	41931	0	@,HM,SH		1,200/12,000	1,500/15,000	30
		60	SQ5	2-1/2	45508	0	#,CS,EF,HM,LT,M		2,000/18,000	2,500/18,000	50
F-250 Super Duty w/Deep Drop Bumper	02-04	70	SQ5	2-1/2	45514	0	#		1,200/12,000	1,700/14,000	20
F-250 Super Duty Except Cab & Chassis	05-07	27	RT4	2	75740	0	FP,HM		900/6,000	1,000/10,000	20
		55	SQ5	2	41931	0	@,EB,HM,SH		1,200/12,000	1,500/15,000	30
		60	SQ5	2-1/2	45508	0	#,CS,EF,HM,LT,M		2,000/18,000	2,500/18,000	50
F-250 Super Duty Except Cab & Chassis	08-16	55	SQ5	2	41931	0	@,EB,HM,SH		1,200/12,000	1,500/15,000	30
		60	SQ5	2-1/2	45508	0	#,CS,EF,HM,LT,M		2,000/18,000	2,500/18,000	50
F-250 Super Duty Except Cab & Chassis, w/Factory 7-Way	17-19										
F-350 Heavy Duty	97	49	RT3	2	37133		GU		500/5,000	750/7,500	35
		34	SQ3	2	75038		GP		500/5,000	800/8,000	30
		37	SQ4	2	40050				600/6,000	1,000/10,000	40
		25	SQ4	2	41004		GP		600/6,000	1,000/10,000	30
		54	RT4	2	37130		GU		700/7,000	1,200/12,000	35
		42	SQ5	2	41904		@,GP,HD		1,000/10,000	1,200/12,000	30
		51	SQ5	2-1/2	45502		#,GU		1,200/12,000	1,700/14,000	45
F-350 Heavy Duty, w/Deep Drop Bumper	97	34	SQ3	2	41504		FP,K,M		500/5,000	1,000/10,000	40

- | | |
|---|--|
| # Titan hitches require use of a 2-1/2" shank Titan ball mount. | HD Will not fit 6 ft. bed pickups except 6 ft. Super Cab. |
| @ Ultra Frame ball mount must be used to achieve maximum weight carrying rating. | HM Hitch crosstube is visible beneath bumper. |
| CS Will fit with full-size spare tire stowed under vehicle. | K Adapter kit (#1685) required with DT #41504/HH #87480/RS #37081 & RS #44143 for 1980 and later F-Series pickups. |
| EB Factory electrical bracket will NOT fit with this hitch. Must use aftermarket electrical box or bracket. | LT Requires removal of factory hitch if equipped. |
| EF Fits all models with standard bumpers. | M Will fit with heavy-duty suspension. |
| FP Spare tire repositioning and/or modification of spare tire carrier may be required. | SH Hitches produced before 09/27/07 are rated at 1200/12000 WC & 1400/14000 WD. |
| GP Hitch crosstube concealed behind bumper. | SU Hitches produced before 03/11/08 are rated at 1000/10000 WC & 1200/12000 WD. |
| GU Will not fit vehicles with factory or aftermarket lower Fascia/Rollpan or Tube Bumper. | |

T-ONE					TOW HARNESS					4-FLAT WIRING				REQ. 4 FLAT WIRING		7-WAY HARDWIRE	BRAKE CONTROL HARNESS	IN			
PC	T-ONE	FN	IN	AMP	CP	PC	TOW HARN	FN	IN	AMP	CP	TYPE	ELEC	POS	CHOICE 1				CHOICE 2	6-WAY ADAPTER	7-WAY ADAPTER
FORD (Continued)																					
E5	118316	BN	5	7.5									A	PU3	119148	20252	20320	20321	20224	3035-P	5
E5	118316	BN	5	7.5									A	PU3	119148	20252	20320	20321	20224	3035-P	5
						E19	118242	BN,RD	5			7-Way	A	PU1,2	119148	20252	20320	20321	20224	3035-P	5
							74682	RD	10			Both	A	PU3	119148	20252					
							85219	RD	5			7-Way									
						E15	118243	BN,RD	5			7-Way	A	PU1,2	119148	20252	20320	20321	20224	3035-P	5
							74682	RD	10			Both	A	PU3	119148	20252					
							85219	RD	5			7-Way									
						E15	118243	BN,RD	5			7-Way	A	PU1,2	119148	20252	20320	20321	20224	3035-P	5
							74682	RD	10			Both	A	PU3	119148	20252					
							85219	RD	5			7-Way									
													A	PU1,2	119148	20252	20320	20321	20224	3035-P	5
													A	PU1,2	119148	20252	20320	20321	20224	3065-P	5
													A	PU1,2	119148	20252	20320	20321	20224	3034-P	20
							74682	RD	10			Both	A	PU3	119148	20252				3036-P	20
E5	118316	BN	5	7.5									A	PU3	119148	20252	20320	20321	20224	3035-P	5
E5	118316	BN	5	7.5									A	PU3	119148	20252	20320	20321	20224	3035-P	5

A 2 wire system.
BN Exterior mounted plug on some or all models. May require an aftermarket electrical mounting box or bracket. (Sold separately)

RD For vehicles equipped with factory tow package may require additional components or may be used as a replacement harness.

RT3 Round Tube Class III 2"
RT4 Round Tube Class IV 2"
SQ3 Square Tube Class III
SQ4 Square Tube Class IV
SQ5 Square Tube Class V

RECEIVER HITCH APPLICATION GUIDE

MODEL / STYLE	YEAR	TRAILER HITCHES									
		PC	REC TYPE	REC SIZE	PART NO.	NO DRILL	FOOTNOTES	OPTIONAL DRAWBAR	WC (LBS.)	WD (LBS.)	IN
FORD (Continued)											
F-350 Super Duty Cab & Chassis, w/34" Wide Frames	99-00	37	SQ4	2	40050				600/6,000	1,000/10,000	40
		34	SQ4	2	41001		FP		600/6,000	1,000/10,000	40
		30	SQ4	2	41547				750/7,500	1,200/12,000	60
		50	SQ5	2	41938		@,CC		1,200/12,000	1,500/15,000	40
		55	SQ5	2	41947		@		1,600/15,000	1,600/16,000	35
		70	SQ5	2	41943		@		2,400/16,000	1,600/16,000	40
		65	SQ5	2-1/2	45516		#		1,200/12,000	1,700/14,000	60
F-350 Super Duty Cab & Chassis, w/34" Wide Frames & w/Deep Drop Bumper	99-00	34	SQ3	2	41504		FP,M		500/5,000	1,000/10,000	40
F-350 Super Duty Except Cab & Chassis	99-01	49	RT3	2	37133				500/5,000	750/7,500	30
		54	RT4	2	37130				700/7,000	1,200/12,000	30
		27	RT4	2	75740	0	FP,HM		900/6,000	1,000/10,000	20
		51	SQ5	2	41922	0	@,GP		1,000/10,000	1,200/12,000	15
		55	SQ5	2	41931	0	@,HM,SH		1,200/12,000	1,500/15,000	30
		60	SQ5	2-1/2	45508	0	#,CS,EF,HM,LT,M		2,000/18,000	2,500/18,000	50
F-350 Super Duty Except Cab & Chassis, w/Factory 7-Way	99-16										
F-350 Super Duty w/Deep Drop Bumper	99-01	70	SQ5	2-1/2	45514	0	#		1,200/12,000	1,700/14,000	20
F-350 Super Duty w/Deep Drop Bumper, w/Factory 7-Way	99-04										
F-350 Super Duty Cab & Chassis, w/34" Wide Frames	01-04	55	SQ5	2	41947		@		1,600/15,000	1,600/16,000	35
		70	SQ5	2	41943		@		2,400/16,000	1,600/16,000	40
F-350 Super Duty Except Cab & Chassis	02-04	49	RT3	2	37133				500/5,000	750/7,500	30
		54	RT4	2	37130				700/7,000	1,200/12,000	30
		27	RT4	2	75740	0	FP,HM		900/6,000	1,000/10,000	20
		51	SQ5	2	41922	0	@,GP		1,000/10,000	1,200/12,000	15
		55	SQ5	2	41931	0	@,HM,SH		1,200/12,000	1,500/15,000	30
		60	SQ5	2-1/2	45508	0	#,CS,EF,HM,LT,M		2,000/18,000	2,500/18,000	50
F-350 Super Duty w/Deep Drop Bumper	02-04	70	SQ5	2-1/2	45514	0	#		1,200/12,000	1,700/14,000	20
F-350 Super Duty Cab & Chassis, w/34" Wide Frames	05-07	55	SQ5	2	41947		@		1,600/15,000	1,600/16,000	35
		70	SQ5	2	41943		@		2,400/16,000	1,600/16,000	40
F-350 Super Duty Except Cab & Chassis	05-07	27	RT4	2	75740	0	FP,HM		900/6,000	1,000/10,000	20
		55	SQ5	2	41931	0	@,EB,HM,SH		1,200/12,000	1,500/15,000	30
		60	SQ5	2-1/2	45508	0	#,CS,EF,HM,LT,M		2,000/18,000	2,500/18,000	50
F-350 Super Duty Cab & Chassis, w/34" Wide Frames	08-16	55	SQ5	2	41947		@		1,600/15,000	1,600/16,000	35
		70	SQ5	2	41943		@		2,400/16,000	1,600/16,000	40
F-350 Super Duty Except Cab & Chassis	08-16	55	SQ5	2	41931	0	@,EB,HM,SH		1,200/12,000	1,500/15,000	30
		60	SQ5	2-1/2	45508	0	#,CS,EF,HM,LT,M		2,000/18,000	2,500/18,000	50
F-350 Super Duty Cab & Chassis, w/34" Wide Frames	17-19	55	SQ5	2	41947		@		1,600/15,000	1,600/16,000	35
		70	SQ5	2	41943		@		2,400/16,000	1,600/16,000	40
F-350 Super Duty Except Cab & Chassis, w/Factory 7-Way	17-19										
F-450 Super Duty Cab & Chassis, w/34" Wide Frames	99-04	30	SQ4	2	41547		@		750/7,500	1,200/12,000	60
		55	SQ5	2	41947		@		1,600/15,000	1,600/16,000	35
		70	SQ5	2	41943		@		2,400/16,000	1,600/16,000	40
		65	SQ5	2-1/2	45516		#		1,200/12,000	1,700/14,000	60
F-450 Super Duty Cab & Chassis, w/34" Wide Frames	05-07	30	SQ4	2	41547		@		750/7,500	1,200/12,000	60
		55	SQ5	2	41947		@		1,600/15,000	1,600/16,000	35
		70	SQ5	2	41943		@		2,400/16,000	1,600/16,000	40
		65	SQ5	2-1/2	45516		#		1,200/12,000	1,700/14,000	60

- # Titan hitches require use of a 2-1/2" shank Titan ball mount.
- @ Ultra Frame ball mount must be used to achieve maximum weight carrying rating.
- CC Requires minimum of 19 in. from end of frame rail to spring shackle bracket.
- CS Will fit with full-size spare tire stowed under vehicle.
- EB Factory electrical bracket will NOT fit with this hitch. Must use aftermarket electrical box or bracket.
- EF Fits all models with standard bumpers.
- FP Spare tire repositioning and/or modification of spare tire carrier may be required.
- GP Hitch crosstube concealed behind bumper.
- HM Hitch crosstube is visible beneath bumper.
- LT Requires removal of factory hitch if equipped.
- M Will fit with heavy-duty suspension.
- SH Hitches produced before 09/27/07 are rated at 1200/12000 WC & 1400/14000 WD.

T-ONE					TOW HARNESS					4-FLAT WIRING				REQ. 4 FLAT WIRING		7-WAY HARDWARE	BRAKE CONTROL HARNESS	IN			
PC	T-ONE	FN	IN	AMP	CP	PC	TOW HARN	FN	IN	AMP	CP	TYPE	ELEC	POS	CHOICE 1				CHOICE 2	6-WAY ADAPTER	7-WAY ADAPTER
FORD (Continued)																					
													A	PU1,2	119148	20252	20320	20321	20224	3035-P	5
													A	PU1,2	119148	20252	20320	20321	20224	3035-P	5
						E15	118243	BN,RD	5			7-Way	A	PU1,2	119148	20252	20320	20321	20224	3035-P	5
							74682 85219	RD RD	10 5			Both 7-Way	A	PU3	119148	20252					
						E15	118243	BN,RD	5			7-Way	A	PU1,2	119148	20252	20320	20321	20224	3035-P	5
							74682 85219	RD RD	10 5			Both 7-Way	A	PU3	119148	20252					
													A	PU1,2	119148	20252	20320	20321	20224	3035-P	5
													A	PU1,2	119148	20252	20320	20321	20224	3035-P	5
													A	PU1,2	119148	20252	20320	20321	20224	3065-P	5
													A	PU1,2	119148	20252	20320	20321	20224	3065-P	5
													A	PU1,2	119148	20252	20320	20321	20224	3034-P	20
													A	PU1,2	119148	20252	20320	20321	20224	3034-P	20
													A	PU1,2	119148	20252	20320	20321	20224	3036-P	20
							74682 85219	RD RD	10 5			Both 7-Way	A	PU3	119148	20252				3036-P	20
													A	PU1,2	119148	20252	20320	20321	20224	3035-P	5
													A	PU1,2	119148	20252	20320	20321	20224	3065-P	5

A 2 wire system.
BN Exterior mounted plug on some or all models. May require an aftermarket electrical mounting box or bracket. (Sold separately)
RD For vehicles equipped with factory tow package may require additional components or may be used as a replacement harness.

RT3 Round Tube Class III 2"
RT4 Round Tube Class IV 2"
SQ3 Square Tube Class III
SQ4 Square Tube Class IV
SQ5 Square Tube Class V

RECEIVER HITCH APPLICATION GUIDE

MODEL / STYLE	YEAR	TRAILER HITCHES									
		PC	REC TYPE	REC SIZE	PART NO.	NO DRILL	FOOTNOTES	OPTIONAL DRAWBAR	WC (LBS.)	WD (LBS.)	IN
FORD (Continued)											
F-450 Super Duty Cab & Chassis, w/34" Wide Frames	08-16	30	SQ4	2	41547		@		750/7,500	1,200/12,000	60
		55	SQ5	2	41947		@		1,600/15,000	1,600/16,000	35
		70	SQ5	2	41943		@		2,400/16,000	1,600/16,000	40
		65	SQ5	2-1/2	45516		#		1,200/12,000	1,700/14,000	60
F-450 Super Duty Except Cab & Chassis	08-10	60	SQ5	2-1/2	45508	0	#,CS,EF,HM,LT,M		2,000/18,000	2,500/18,000	50
F-450 Super Duty Except Cab & Chassis, w/Factory 7-Way	08-16										
F-450 Super Duty Except Cab & Chassis	11-15	60	SQ5	2-1/2	45508	0	#,CS,EF,HM,LT,M		2,000/18,000	2,500/18,000	50
F-450 Super Duty Cab & Chassis, w/34" Wide Frames	17	30	SQ4	2	41547		#		750/7,500	1,200/12,000	60
		65	SQ5	2-1/2	45516		#		1,200/12,000	1,700/14,000	60
F-450 Super Duty Cab & Chassis, w/34" Wide Frames	17-19	55	SQ5	2	41947		@		1,600/15,000	1,600/16,000	35
		70	SQ5	2	41943		@		2,400/16,000	1,600/16,000	40
F-450 Super Duty Except Cab & Chassis, w/Factory 7-Way	17-19										
F-550 Super Duty Cab & Chassis, w/34" Wide Frames	99-04	30	SQ4	2	41547		@		750/7,500	1,200/12,000	60
		55	SQ5	2	41947		@		1,600/15,000	1,600/16,000	35
		70	SQ5	2	41943		@		2,400/16,000	1,600/16,000	40
		65	SQ5	2-1/2	45516		#		1,200/12,000	1,700/14,000	60
F-550 Super Duty Cab & Chassis, w/34" Wide Frames	05-07	30	SQ4	2	41547		@		750/7,500	1,200/12,000	60
		55	SQ5	2	41947		@		1,600/15,000	1,600/16,000	35
		70	SQ5	2	41943		@		2,400/16,000	1,600/16,000	40
		65	SQ5	2-1/2	45516		#		1,200/12,000	1,700/14,000	60
F-550 Super Duty Cab & Chassis, w/34" Wide Frames	08-16	30	SQ4	2	41547		@		750/7,500	1,200/12,000	60
		55	SQ5	2	41947		@		1,600/15,000	1,600/16,000	35
		70	SQ5	2	41943		@		2,400/16,000	1,600/16,000	40
		65	SQ5	2-1/2	45516		#		1,200/12,000	1,700/14,000	60
F-550 Super Duty Cab & Chassis, w/34" Wide Frames	17	30	SQ4	2	41547		#		750/7,500	1,200/12,000	60
		65	SQ5	2-1/2	45516		#		1,200/12,000	1,700/14,000	60
F-550 Super Duty Cab & Chassis, w/34" Wide Frames	17-19	55	SQ5	2	41947		@		1,600/15,000	1,600/16,000	35
		70	SQ5	2	41943		@		2,400/16,000	1,600/16,000	40
Fiesta 4 Dr. Sedan	11-13	37	SQ1	1-1/4	24856	0	HM	3593	200/2,000		15
Fiesta 5 Dr. Hatchback	11-13	25	SQ1	1-1/4	24855	0	HM,JR,KH	3593	200/2,000		30
		19	SQ1	1-1/4	24961	0	HM,JR,KH	3594	200/2,000		30
Fiesta 4 Dr. Sedan	14-19	31	SQ1	1-1/4	24910	0	HM	3593	200/2,000		15
Fiesta 5 Dr. Hatchback	14-19	25	SQ1	1-1/4	24855	0	HM,JR,KH	3593	200/2,000		30
		19	SQ1	1-1/4	24961	0	HM,JR,KH	3594	200/2,000		30
Five Hundred	05-07	33	SQ2	1-1/4	36360	0	GP,JR	36071	300/3,500		30
		42	SQ3	2	75299	0	JR		350/3,500	400/4,000	30
Flex	09-11	45	RT3	2	75679	0	HM,JR		400/4,000	400/4,000	30
Flex w/Factory 7-Way	09-12										
Flex	12-19	45	RT3	2	75679	0	HM,JR		400/4,000	400/4,000	30
Focus Sedan	00	24	SQ1	1-1/4	24692	0	HM	3593	200/2,000		20
Focus Wagon (Built Before 11/2002)	00-02	33	SQ1	1-1/4	24682	0	JR,GP	3592	200/2,000		20
Focus Sedan	01-04	24	SQ1	1-1/4	24692	0	HM	3593	200/2,000		20
Focus Wagon (Built After 11/2002)	03-07	33	SQ1	1-1/4	24682	0	JR,GP	3592	200/2,000		20
Focus Sedan, Except w/Street Appearance Pkg.	05-07	24	SQ1	1-1/4	24692	0	HM	3593	200/2,000		20
Focus	08-11	33	SQ1	1-1/4	24805	0	HM,JR,KH	3593	200/2,000		30
Focus 5 Dr. Hatchback, Except ST w/Center Exhaust	12-14	18	SQ1	1-1/4	24872	0	GP,JR,KH	3593	200/2,000		25
Focus Sedan	12-18	18	SQ1	1-1/4	24872	0	GP,JR,KH	3593	200/2,000		25
Focus 5 Dr. Hatchback, Except ST w/Center Exhaust Models & RS	15-18	18	SQ1	1-1/4	24872	0	GP,JR,KH	3593	200/2,000		25
Focus RS	16-18	33	SQ1	1-1/4	24977	0	DU,GP,TA,X	3593	200/2,000		60

- # Titan hitches require use of a 2-1/2" shank Titan ball mount.
- @ Ultra Frame ball mount must be used to achieve maximum weight carrying rating.
- CS Will fit with full-size spare tire stowed under vehicle.
- DU Fascia removal required.
- EF Fits all models with standard bumpers.
- GP Hitch crosstube concealed behind bumper.
- HM Hitch crosstube is visible beneath bumper.

- JR Exhaust must be temporarily lowered for installation.
- KH Minor heat shield modification may be required.
- LT Requires removal of factory hitch if equipped.
- M Will fit with heavy-duty suspension.
- TA Trunk access required for hitch installation.
- X Minor fascia trimming required.

T-ONE					TOW HARNESS					4-FLAT WIRING				REQ. 4 FLAT WIRING		7-WAY HARDWIRE	BRAKE CONTROL HARNESS	IN			
PC	T-ONE	FN	IN	AMP	CP	PC	TOW HARN	FN	IN	AMP	CP	TYPE	ELEC	POS	CHOICE 1				CHOICE 2	6-WAY ADAPTER	7-WAY ADAPTER
FORD (Continued)																					
													A	PU1,2	119148	20252	20320	20321	20224	3034-P	20
													A	PU1,2	119148	20252	20320	20321	20224	3034-P	20
							74682 85219	RD	RD	10 5		Both 7-Way	A	PU3	119148	20252					
													A	PU1,2	119148	20252	20320	20321	20224	3034-P	20
													A	PU1,2	119148	20252	20320	20321	20224	3036-P	20
													A	PU1,2	119148	20252	20320	20321	20224	3036-P	20
							74682 85219	RD	RD	10 5		Both 7-Way	A	PU3	119148	20252				3036-P	20
													A	PU1,2	119148	20252	20320	20321	20224	3035-P	5
													A	PU1,2	119148	20252	20320	20321	20224	3065-P	5
													A	PU1,2	119148	20252	20320	20321	20224	3034-P	20
													A	PU1,2	119148	20252	20320	20321	20224	3036-P	20
													A	PU1,2	119148	20252	20320	20321	20224	3036-P	20
E14	118422	CH	30	2.1,4.2	X								A,E	PC3,4	119191	119148					
E18	118471	CH	45	2.1,5.6	X								B,E	PC3,4	119191	119148					
E14	118766	CH	45	4.2,7.5	X								A,E	PC3,4	119191	119148					
E15	118641	CH	45	2.1,5.6	X								B,E	PC3,4	119191	119148					
E5	118395		10	7.5									A	PC3,4	119148	20252	20320	20321	20224		
E8	118472		15	7.5									A	SUV1,2	119148	20252	20320	20321	20224	3035-P	5
							74682 85219	RD	RD	10 5		Both 7-Way	A	SUV6	119148	20252					
E8	118472		15	7.5									A	SUV1,2	119148	20252	20320	20321	20224	3036-P	20
													B	PC3,4	119130	119178					
E5	118344	FW	10	7.5									A	PC1,2	119148	20252					
													C	PC3,4	119191	119148					
													A	PC1,2	119148	20252					
													A	PC3,4	119148	20252					
E5	118457	BN	15	7.5									A	PC1,2	119148	20252					
E18	118549	CH	45	2.1,5.6	X								B,E	PC1,2	119191	119148					
E16	118548	CH	45	2.1,5.6	X								B,E	PC1,2	119191	119148					
E18	118674	CH	45	4.2,7.5	X								B,E	PC1,2	119191	119148					
E16	118548	CH	45	2.1,5.6	X								B,E	PC3,4	119191	119148					

A 2 wire system.
B 3 wire system. Converter required.
BN Exterior mounted plug on some or all models. May require an aftermarket electrical mounting box or bracket. (Sold separately)
C 2 or 3 wire system determine at installation.

CH T-One is equipped with circuit protected ModuLite® module.
E ModuLite® required.
FW 2003 Models w/Build date before 11/1/02.
RD For vehicles equipped with factory tow package may require additional components or may be used as a replacement harness.

RT3 Round Tube Class III 2"
SQ1 Square Tube Class I
SQ2 Square Tube Class II
SQ3 Square Tube Class III
SQ4 Square Tube Class IV
SQ5 Square Tube Class V

RECEIVER HITCH APPLICATION GUIDE

MODEL / STYLE	YEAR	TRAILER HITCHES									
		PC	REC TYPE	REC SIZE	PART NO.	NO DRILL	FOOTNOTES	OPTIONAL DRAWBAR	WC (LBS.)	WD (LBS.)	IN
FORD (Continued)											
Focus ZX3 3 Dr. Hatchback, Except SVT & w/Street Appearance Pkg.	00-06	24	SQ1	1-1/4	24692		HM	3593	200/2,000		20
Focus ZX5 5 Dr. Hatchback, Except SVT & w/Street Appearance Pkg.	02-06	24	SQ1	1-1/4	24692		HM	3593	200/2,000		20
Freestar	04-07	41	SQ2	1-1/4	36318	0	GP, JR	36071	300/3,500		25
		45	SQ3	2	75158		GP, JR		350/3,500	500/5,000	30
Freestyle	05-07	33	SQ2	1-1/4	36360	0	GP, JR	36071	300/3,500		30
		42	SQ3	2	75299	0	JR		350/3,500	400/4,000	30
Fusion	06-09	35	SQ1	1-1/4	24775		GP, JR, TA	3592	200/2,000		45
Fusion	10-12	25	SQ1	1-1/4	24865	0	GP, JR	3594	200/2,000		20
Fusion Except Sport	13-19	19	SQ1	1-1/4	24897	0	HM, SV	3594	200/2,000		20
Mustang	94-98	29	SQ1	1-1/4	24687		RB, GP	3592	200/2,000		20
Mustang Except Cobra SVT	99-04	29	SQ1	1-1/4	24687		RB, GP	3592	200/2,000		20
Mustang Except GT/CS (California Special)/Shelby GT/GT500	05-09	22	SQ1	1-1/4	24747		GP, JR	3592	200/2,000		45
Mustang Except GT/CS (California Special)/Shelby GT/GT500	10	23	SQ1	1-1/4	24840†		†, GP, JR, X	3592	200/2,000		45
Mustang V6 Models	11-14	24	SQ1	1-1/4	24863	0	HM, JR	3594	200/2,000		40
Mustang V8 Models	11-14	24	SQ1	1-1/4	24863	0	GP, HB, JR	3594	200/2,000		40
Mustang	15-17	43	SQ1	1-1/4	24928	0	HM, JR, AI	3594	200/2,000		30
Mustang	18-19	43	SQ1	1-1/4	24928	0	HM, JR, AI	3594	200/2,000		30
Ranger	93-97	24	SQ3	2	75082		EG, SD, V, GP		400/4,000	750/6,000	20
Ranger Except w/Rear Fascia	93-97	50	SQ3	2	37136	0			500/5,000	600/6,000	40
Ranger	98	24	SQ3	2	75082		SD, V, GP		400/4,000	750/6,000	20
Ranger Except Flareside or w/Rear Fascia	98-99	50	SQ3	2	37136	0			500/5,000	600/6,000	40
Ranger	99	24	SQ3	2	75082		SD, V, GP		400/4,000	750/6,000	20
Ranger	00-03	24	SQ3	2	75082		SD, V, GP		400/4,000	750/6,000	20
Ranger Except Flareside or w/Rear Fascia	00-03	50	SQ3	2	37136	0			500/5,000	600/6,000	40
Ranger w/Factory 7-Way	00-11										
Ranger	04-11	24	SQ3	2	75082		SD, V, GP		400/4,000	750/6,000	20
Ranger Except Flareside or w/Rear Fascia	04-11	50	SQ3	2	37136	0			500/5,000	600/6,000	40
Ranger	13-16	54	RT3	2	75790	0	HM, CS		600/4,000	600/6,000	30
Ranger	19	18	SQ3	2	76275	0	CP, J		1,125/7,500	1,200/8,000	20
Taurus 4 Dr. Sedan, Except SHO	96-99	35	SQ1	1-1/4	24699	0	GP, JR	3593	200/2,000		20
		35	SQ2	1-1/4	36252	0	GP, JR	36063	300/3,500		20
Taurus SHO	96-99	35	SQ2	1-1/4	36252	0	GP, JR	36063	300/3,500		20
Taurus Wagon	96-99	35	SQ1	1-1/4	24699	0	GP, JR	3593	200/2,000		20
		35	SQ2	1-1/4	36252	0	GP, JR	36063	300/3,500		20
Taurus 4 Dr. Sedan	00-03	35	SQ1	1-1/4	24699	0	GP, JR	3592	200/2,000		20
		35	SQ2	1-1/4	36252	0	GP, JR	36063	300/3,500		20
		47	SQ2	1-1/4	36313	0	GP, JR	36061	300/3,500		40
Taurus Wagon	00-03	35	SQ1	1-1/4	24699	0	GP, JR	3592	200/2,000		20
		35	SQ2	1-1/4	36252	0	GP, JR	36063	300/3,500		20
		47	SQ2	1-1/4	36313	0	GP, JR	36061	300/3,500		40
Taurus 4 Dr. Sedan	04-06	47	SQ2	1-1/4	36313	0	GP, JR	36061	300/3,500		40
Taurus Wagon	04-06	47	SQ2	1-1/4	36313	0	GP, JR	36061	300/3,500		40
Taurus 4 Dr. Sedan	08-09	33	SQ2	1-1/4	36360	0	GP, JR	36071	300/3,500		30
		42	SQ3	2	75299	0	JR		350/3,500	400/4,000	30
Taurus 4 Dr. Sedan	10-19	36	SQ2	1-1/4	36492		GP, JR	36071	300/3,500		30
		45	SQ3	2	75670		GP, JR		400/4,000	400/4,000	30
Taurus X	08-09	33	SQ2	1-1/4	36360	0	GP, JR	36071	300/3,500		30
		42	SQ3	2	75299	0	JR		350/3,500	400/4,000	30
Thunderbird	96-97	41	SQ2	1-1/4	36179	0	GP	36063	300/3,500		40
Transit Connect	10-13	33	RT3	2	75678	0			350/3,500	400/4,000	20

† Available while supply lasts.
 AI Additional installation time may be required.
 CP Fits all models without factory installed receiver.
 CS Will fit with full-size spare tire stowed under vehicle.
 EG Relocation of spare tire bracket is not required. NOTE: 19mm open end style wrench must be purchased to allow removal of spare tire after hitch installation.
 GP Hitch crosstube concealed behind bumper.
 HB Slight fascia deformation may occur on some models.
 HM Hitch crosstube is visible beneath bumper.

J Under vehicle spare tire stowage is retained.
 JR Exhaust must be temporarily lowered for installation.
 RB Hitch installation can be made easier with a cutter type drill bit.
 SD Hitches produced before 07/21/06 are rated at 350/3500 WC.
 SV Trimming or removal of under body appearance panel may be required.
 TA Trunk access required for hitch installation.
 V For vehicles with factory installed step bumpers only.
 X Minor fascia trimming required.

T-ONE					TOW HARNESS					4-FLAT WIRING				REQ. 4 FLAT WIRING		7-WAY HARDWARE	BRAKE CONTROL HARNESS	IN	
PC	T-ONE	FN	IN	AMP	CP	PC	TOW HARN	FN	IN	AMP	CP	TYPE	ELEC	POS	CHOICE 1				CHOICE 2
FORD (Continued)																			
													A	PC1,2	119148	20252			
													A	PC1,2	119148	20252			
E17	118385	CH	45	2.1,5.6	X								N	SUV1,2		119251	20320	20321	
E5	118395		10	7.5									A	SUV3,4	119148	20252	20320	20321	20224
E14	118422	CH	30	2.1,4.2	X								A,E	PC3,4	119191	119148			
E14	118422	CH	30	2.1,4.2	X								A,E	PC3,4	119191	119148			
E16	118574	CH	45	2.1,5.6	X								A,E	PC1,2	119191	119148			
E9	118326		20	7.5									A	PC3,4	119148	20252			
E9	118326		20	7.5									A	PC3,4	119148	20252			
													A	PC3,4	119148	20252			
E16	118487	CH	45	2.1,5.6	X								A,E	PC3,4	119191	119148			
E16	118487	CH	45	2.1,5.6	X								A,E	PC3,4	119191	119148			
E16	118487	CH	45	2.1,5.6	X								A,E	PC3,4	119191	119148			
E16	118487	CH	45	2.1,5.6	X								A,E	PC3,4	119191	119148			
E12	118325	BN,HG	5	2.1,5									B	PU3	119130	119178	20320	20321	20224
E12	118325	BN,HG	5	2.1,5									B	PU3	119130	119178	20320	20321	20224
E12	118325	BN,HG	5	2.1,5		E3	118241	BN,RD	5	7.5		4-Flat	B	PU3	119130	119178	20320	20321	20224
E12	118325	BN,HG	5	2.1,5		E3	118241	BN,RD	5	7.5		4-Flat	B	PU3	119130	119178	20320	20321	20224
E12	118325	BN,HG	5	2.1,5		E3	118241	BN,RD	5	7.5		4-Flat	B	PU3	119130	119178	20320	20321	20224
E5	118344	BN	10	7.5									A	PU1,2	119148	20252	20320	20321	20224
E5	118344	BN	10	7.5									A	PU1,2	119148	20252	20320	20321	20224
							74682 85219	RD RD	10 5			Both 7-Way	A	PU5	119148	20252			20224
													A	PU1,2	119148	20252	20320	20321	20224
													A	PU1,2	119148	20252	20320	20321	20224
E16	118654	CH,BN	45	4.2,7.5	X								B,E	PU3,4	119191	119148	20320	20321	
						E20	22124		45			7-Way	A	PU3					7865
E9	118333	HG	10	2.1,5									B	PC3,4	119130	119178			
E9	118333	HG	10	2.1,5									B	PC3,4	119130	119178			
													B	PC3,4	119130	119178			
E4	118375		10	7.5									A	PC3,4	119148	20252			
													C	PC3,4	119191	119148			
													A	PC3,4	119148	20252			
													A	PC3,4	119148	20252			
E7	118447		10	7.5									A	PC3,4	119148	20252	20320	20321	20224
E15	118599	CH	45	2.1,5.6	X								B,E	PC3,4	119191	119148	20320	20321	20224
E7	118448		15	7.5									A	SUV3,4	119148	20252	20320	20321	20224
													A,E	PC3,4	119191	119148			
E26	118585	BN,CH	45	4.2,7.5	X								B,E	SUV1,2	119191	119148	20320	20321	20224

A 2 wire system.
B 3 wire system. Converter required.
BN Exterior mounted plug on some or all models. May require an aftermarket electrical mounting box or bracket. (Sold separately)
C 2 or 3 wire system determine at installation.
CH T-One is equipped with circuit protected ModuLite® module.
E ModuLite® required.
HG T-One incorporates taillight converter.
N DO NOT cut or splice vehicle wiring. Only use approved T-One or see auto dealer for trailer tow wiring kit.
RD For vehicles equipped with factory tow package may require additional components or may be used as a replacement harness.

RT3 Round Tube Class III 2"
SQ1 Square Tube Class I
SQ2 Square Tube Class II
SQ3 Square Tube Class III

RECEIVER HITCH APPLICATION GUIDE

FORD

MODEL / STYLE	YEAR	TRAILER HITCHES									
		PC	REC TYPE	REC SIZE	PART NO.	NO DRILL	FOOTNOTES	OPTIONAL DRAWBAR	WC (LBS.)	WD (LBS.)	IN
FORD (Continued)											
Transit Connect	14-19	32	RT3	2	75852	0	HM		400/3,500	400/4,000	15
Transit-150 Except Cab & Chassis and the Cutaway	15-19	27	RT3	2	75912	0	HM		750/5,000	800/8,000	25
Transit-250 Except Cab & Chassis and the Cutaway	15-19	27	RT3	2	75912	0	HM		750/5,000	800/8,000	25
Transit-350 Except Single Rear Wheel w/148" Wheelbase or Cab & Chassis and the Cutaway	15-19	27	RT3	2	75912	0	HM		750/5,000	800/8,000	25
Transit-350 Single Rear Wheel w/148" Wheelbase, Except Cab & Chassis and the Cutaway	15-19	27	RT3	2	75912	0	HM		750/5,000	800/8,000	25
Windstar	95-98	30	SQ2	1-1/4	36189		GP	36061	300/3,500		30
		43	SQ3	2	75055		GP		350/3,500	500/5,000	40
Windstar (Built Before 11/2002)	99-03	30	SQ2	1-1/4	36189		GP	36061	300/3,500		30
		43	SQ3	2	75055		GP		350/3,500	500/5,000	40
		50	SQ3	2	37136	0	AF		500/5,000	600/6,000	40
Windstar (Built After 11/2002)	03	30	SQ2	1-1/4	36189		GP	36061	300/3,500		30
		43	SQ3	2	75055		GP		350/3,500	500/5,000	40
		50	SQ3	2	37136	0	AF		500/5,000	600/6,000	40
FREIGHTLINER											
SL	04-16										
Sprinter 2500 w/41" Wide Frames, Except 118" Wheelbase & Factory Metal Step Platform	03-06	48	SQ3	2	75210	0	HM		500/5,000	750/7,500	20
Sprinter 2500 w/41" Wide Frames, Except 118" Wheelbase & Factory Metal Step Platform, w/Factory 7-Way	03-06										
Sprinter 2500 144" & 170" Wheelbase, Except w/Factory Step Bumper	07-09	53	SQ4	2	75549	0	HM,UL		600/6,000	750/7,500	20
Sprinter 2500 144" & 170" Wheelbase, Except w/Factory Step Bumper, w/Factory 7-Way	07-09										
Sprinter 2500 w/Factory Step Bumper Excluding Models w/30-3/8" Frame Width	07-09	52	SQ3	2	75601	0	HM		500/5,000	750/7,500	30
Sprinter 2500 w/Factory Step Bumper, w/Factory 7-Way	07-09										
Sprinter 2500 144" & 170" Wheelbase, Except w/Factory Step Bumper	10-12	53	SQ4	2	75549	0	HM,UL		600/6,000	750/7,500	20
Sprinter 2500 w/Factory Step Bumper Excluding Models w/30-3/8" Frame Width	10-12	52	SQ3	2	75601	0	HM		500/5,000	750/7,500	30
Sprinter 2500 144" & 170" Wheelbase, Except w/Factory Step Bumper	13	53	SQ4	2	75549	0	HM,UL		600/6,000	750/7,500	20
Sprinter 2500 w/Factory Step Bumper Excluding Models w/30-3/8" Frame Width	13	52	SQ3	2	75601	0	HM		500/5,000	750/7,500	30
Sprinter 3500 w/41" Wide Frames, Except 118" Wheelbase & Factory Metal Step Platform	03-06	48	SQ3	2	75210	0	HM		500/5,000	750/7,500	20
Sprinter 3500 w/41" Wide Frames, Except 118" Wheelbase & Factory Metal Step Platform, w/Factory 7-Way	03-06										
Sprinter 3500 144" & 170" Wheelbase, Except w/Factory Step Bumper	07-09	53	SQ4	2	75549	0	HM,UL		600/6,000	750/7,500	20
Sprinter 3500 144" & 170" Wheelbase, Except w/Factory Step Bumper, w/Factory 7-Way	07-09										
Sprinter 3500 w/Factory Step Bumper Excluding Models w/30-3/8" Frame Width	07-09	52	SQ3	2	75601	0	HM		500/5,000	750/7,500	30
Sprinter 3500 w/Factory Step Bumper, w/Factory 7-Way	07-09										
Sprinter 3500 144" & 170" Wheelbase, Except w/Factory Step Bumper	10-12	53	SQ4	2	75549	0	HM,UL		600/6,000	750/7,500	20
Sprinter 3500 w/Factory Step Bumper Excluding Models w/30-3/8" Frame Width	10-12	52	SQ3	2	75601	0	HM		500/5,000	750/7,500	30
Sprinter 3500 144" & 170" Wheelbase, Except w/Factory Step Bumper	13	53	SQ4	2	75549	0	HM,UL		600/6,000	750/7,500	20

AF Hitch is ONLY rated for Weight Carrying at 3500 lbs. GTW / 350 lbs. TW and DO NOT use Weight Distribution Spring Bars for this Specific Vehicle. Except for long bed pickups.
GP Hitch cross-tube concealed behind bumper.

HM Hitch cross-tube is visible beneath bumper.
UL This hitch will not fit a Sprinter single or dual rear-wheel vehicle with a 30-3/8 in. wide frame measured outside of frame to outside of frame.

RECEIVER HITCHES

T-ONE						TOW HARNESS					4-FLAT WIRING				REQ. 4 FLAT WIRING		7-WAY HARDWIRE	BRAKE CONTROL HARNESS	IN	
PC	T-ONE	FN	IN	AMP	CP	PC	TOW HARN	FN	IN	AMP	CP	TYPE	ELEC	POS	CHOICE 1	CHOICE 2				6-WAY ADAPTER
FORD (Continued)																				
E14	118613	BN,CH	45	4.2,7.5	X								B,E	SUV3,4	119191	119148	20320	20321	20224	
E16	118643	CH	45	4.2,7.5	X		22114		60			7-Way	A,E	SUV1,2	119191	119148	20320	20321	20224	
E16	118643	CH	45	4.2,7.5	X		22114		60			7-Way	A,E	SUV1,2	119191	119148	20320	20321	20224	
E18	118722	BN,CH	45	5.7.5	X		22116		90			7-Way	A,E	SUV1,2	119191	119148	20320	20321	20224	
E16	118643	BN,CH	45	4.2,7.5	X		22114		60			7-Way	A,E	SUV1,2	119191	119148	20320	20321	20224	
		HG											B	SUV1,2	119130	119178	20320	20321	20224	3035-P 5
E19	118366	FW,LS	45	2.1,4.2									G	SUV1,2		119251	20320	20321		3035-P 5
E19	118305	FV,LS	45	2.1,4.2									G	SUV1,2		119251	20320	20321		3035-P 5
FREIGHTLINER																				
						E3	118381	BN,RD	5	7.5		4-Flat	B,E	SUV3,4	119148	20252	20320	20321	20224	3027-P 5
							20135	RD	10			Both	H	SUV6	119148	20252				3063-P 10
E17	118650	CH	45	5.7.5	X	E3	118381	BN,RD	5	7.5		4-Flat	B,E	SUV1,2	119191	119148	20320	20321	20224	3063-P 10
							20135	RD	10			Both	H	SUV6	119148	20252				
E17	118650	CH	45	5.7.5	X	E3	118381	BN,RD	5	7.5		4-Flat	B,E	SUV1,2	119191	119148	20320	20321	20224	3063-P 10
							20135	RD	10			Both	H	SUV6	119148	20252				
E17	118650	CH	45	5.7.5	X								B,E	SUV1,2	119191	119148	20320	20321	20224	
E17	118650	CH	45	5.7.5	X								B,E	SUV1,2	119191	119148	20320	20321	20224	
E17	118650	CH	45	5.7.5	X								B,E	SUV3,4	119192	119191	20320	20321	20224	
E17	118650	CH	45	5.7.5	X								B,E	SUV3,4	119192	119191	20320	20321	20224	
						E3	118381	BN,RD	5	7.5		4-Flat	B,E	SUV3,4	119191	119148	20320	20321	20224	
							20135	RD	10			Both	H	SUV6	119148	20252				
E17	118650	CH	45	5.7.5	X	E3	118381	BN,RD	5	7.5		4-Flat	B,E	SUV1,2	119191	119148	20320	20321	20224	
							20135	RD	10			Both	H	SUV6	119148	20252				
E17	118650	CH	45	5.7.5	X	E3	118381	BN,RD	5	7.5		4-Flat	B,E	SUV1,2	119191	119148	20320	20321	20224	
							20135	RD	10			Both	H	SUV6	119148	20252				
E17	118650	CH	45	5.7.5	X								B,E	SUV1,2	119191	119148	20320	20321	20224	
E17	118650	CH	45	5.7.5	X								B,E	SUV1,2	119191	119148	20320	20321	20224	
E17	118650	CH	45	5.7.5	X								B,E	SUV3,4	119251	119191	20320	20321	20224	

A 2 wire system.
B 3 wire system. Converter required.
BN Exterior mounted plug on some or all models. May require an aftermarket electrical mounting box or bracket. (Sold separately)
CH T-One is equipped with circuit protected ModuLite® module.
E ModuLite® required.
FV 2003 Models w/Build date after 11/1/02.
FW 2003 Models w/Build date before 11/1/02.
G Low-side switching system.
H 3 wire system with OEM standard 2 wire harness.
HG T-One incorporates taillight converter.
LS T-One incorporates low-side switching taillight converter. Additional installation time required.
RD For vehicles equipped with factory tow package may require additional components or may be used as a replacement harness.

RT3 Round Tube Class III 2"
SQ2 Square Tube Class II
SQ3 Square Tube Class III
SQ4 Square Tube Class IV

FREIGHTLINER

RECEIVER HITCHES

RECEIVER HITCH APPLICATION GUIDE

MODEL / STYLE	YEAR	TRAILER HITCHES									
		PC	REC TYPE	REC SIZE	PART NO.	NO DRILL	FOOTNOTES	OPTIONAL DRAWBAR	WC (LBS.)	WD (LBS.)	IN
FREIGHTLINER (Continued)											
Sprinter 3500 w/Factory Step Bumper Excluding Models w/30-3/8" Frame Width	13	52	SQ3	2	75601	0	HM		500/5,000	750/7,500	30
XC	04-16										
GENESIS											
G80	17-18										
GEO											
Prizm	93-97	25	SQ1	1-1/4	24579		GP	3593	200/2,000		30
Tracker	96-97	24	SQ1	1-1/4	24622	0	HM	3593	200/2,000		20
GMC											
Acadia	07-12	19	RT3	2	75528	0	GP,JR,TN		750/5,000	750/7,500	25
Acadia w/Factory 7-Way	07-12										
Acadia	13-16	19	RT3	2	75528	0	GP,JR,TN		750/5,000	750/7,500	25
Acadia	17	24	SQ3	2	76023	0	GP,JR,AA,DU,SV,TA		675/4,500	675/4,500	90
Acadia	18-19	24	SQ3	2	76023	0	GP,JR,AA,DU,SV,TA		675/4,500	675/4,500	90
Acadia Limited	17	19	RT3	2	75528	0	GP,JR,TN		750/5,000	750/7,500	25
C1500 w/34" Wide Frames	85-99	50	SQ5	2	41938		@,CC		1,200/12,000	1,500/15,000	40
		55	SQ5	2	41947		@		1,600/15,000	1,600/16,000	35
C1500	88-99	49	RT3	2	37133				500/5,000	750/7,500	40
		35	SQ3	2	75033	0	HM,J		500/5,000	800/8,000	20
		25	SQ3	2	75099	0	GP		500/5,000	800/8,000	20
		37	SQ4	2	40050		HC		600/6,000	1,000/10,000	40
		44	SQ4	2	41524	0	GP		600/6,000	1,000/10,000	20
		38	SQ4	2	415251	0	HM,J		600/6,000	1,000/10,000	20
		54	RT4	2	37130				700/7,000	1,200/12,000	40
		45	SQ5	2	41901		@,DB,GP,SN		1,000/10,000	1,300/13,000	30
C1500 w/10" Deep Drop Bumper	88-99	49	SQ4	2	41528	0	FS,J		600/6,000	1,000/10,000	20
C1500 w/Aftermarket Roll Pan	88-99	37	SQ3	2	41522		CO,HK		500/5,000	550/5,500	40
C2500 w/34" Wide Frames	85-00	50	SQ5	2	41938		@,CC		1,200/12,000	1,500/15,000	40
		55	SQ5	2	41947		@		1,600/15,000	1,600/16,000	35
C2500	88-00	49	RT3	2	37133				500/5,000	750/7,500	40
		35	SQ3	2	75033	0	HM,J		500/5,000	800/8,000	20
		25	SQ3	2	75099	0	GP		500/5,000	800/8,000	20
		37	SQ4	2	40050		HC		600/6,000	1,000/10,000	40
		44	SQ4	2	41524	0	GP		600/6,000	1,000/10,000	20
		38	SQ4	2	415251	0	HM,J		600/6,000	1,000/10,000	20
		54	RT4	2	37130				700/7,000	1,200/12,000	40
		45	SQ5	2	41901		@,DB,GP,SN		1,000/10,000	1,300/13,000	30
		59	SQ5	2-1/2	45506		#		1,200/12,000	1,700/14,000	45
C2500 w/10" Deep Drop Bumper	88-00	49	SQ4	2	41528	0	FS,J		600/6,000	1,000/10,000	20
C2500 w/Aftermarket Roll Pan	88-00	37	SQ3	2	41522		CO,HK		500/5,000	550/5,500	40
C3500 w/34" Wide Frames	85-00	50	SQ5	2	41938		@,CC		1,200/12,000	1,500/15,000	40
		55	SQ5	2	41947		@		1,600/15,000	1,600/16,000	35
C3500	88-00	49	RT3	2	37133				500/5,000	750/7,500	40
		35	SQ3	2	75033	0	HM,J		500/5,000	800/8,000	20
		25	SQ3	2	75099	0	GP		500/5,000	800/8,000	20
		37	SQ4	2	40050		HC		600/6,000	1,000/10,000	40
		44	SQ4	2	41524	0	GP		600/6,000	1,000/10,000	20
		38	SQ4	2	415251	0	HM,J		600/6,000	1,000/10,000	20
		54	RT4	2	37130				700/7,000	1,200/12,000	40
		45	SQ5	2	41901		@,DB,GP,SN		1,000/10,000	1,300/13,000	30
		59	SQ5	2-1/2	45506		#		1,200/12,000	1,700/14,000	45

- | | | | |
|----|---|----|---|
| # | Titan hitches require use of a 2-1/2" shank Titan ball mount. | HC | Will not fit with mini or full size tire stowed under vehicle. |
| @ | Ultra Frame ball mount must be used to achieve maximum weight carrying rating. | HK | Under vehicle spare tire stowage may be retained with installation of an aftermarket spare tire repositioner. Cutting of rollpan in license plate area required for receiver tube access. Does not fit with bumper. |
| AA | Requires temporary removal of bumper during installation. | HM | Hitch crosstube is visible beneath bumper. |
| CC | Requires minimum of 19 in. from end of frame rail to spring shackle bracket. | J | Under vehicle spare tire stowage is retained. |
| CO | Will not fit 8 ft. 2500/3500 Series with heavy-duty suspension or four door Crew Cab. | JR | Exhaust must be temporarily lowered for installation. |
| DB | Will not fit 6 ft. bed pickups. | SN | Hitches produced before 04/28/08 are rated at 1000/10000 WC & 1200/12000 WD. |
| DU | Fascia removal required. | SV | Trimming or removal of under body appearance panel may be required. |
| FS | Includes 2 & 4 WD models with heavy duty suspension. | TA | Trunk access required for hitch installation. |
| GP | Hitch crosstube concealed behind bumper. | TN | Hitches produced before 07/09/12 are rated at 500/5000 WC & 500/5000 WD. |

T-ONE						TOW HARNESS						4-FLAT WIRING				REQ. 4 FLAT WIRING		7-WAY HARDWARE	BRAKE CONTROL HARNESS	IN	
PC	T-ONE	FN	IN	AMP	CP	PC	TOW HARN	FN	IN	AMP	CP	TYPE	ELEC	POS	CHOICE 1	CHOICE 2	6-WAY ADAPTER				7-WAY ADAPTER
FREIGHTLINER (Continued)																					
E17	118650	CH	45	5.7,5	X								B,E	SUV3,4	119251	119191	20320	20321	20224		
																				3027-P	5
GENESIS																					
E13	118738	CH	45	5.7,5	X								B,E	PC3,4	119191	119148					
GEO																					
E5	118372	HG	5	2.1,5									B	PC3,4	119130	119178					
													B	SUV1,2	119130	119178					
GMC																					
E11	118451	BN	15	7.5		E8	118384	BN,RD	5	7.5		4-Flat	N	SUV1,2		119251	20320	20321		3026-P	5
							8551511	RD				7-Way	N	SUV6		119251					
							74682	RD	10			Both									
							85219	RD	5			7-Way									
E10	118270	BN	20	7.5		E16	118271	BN	20			7-Way	A,E	SUV1,2	119191	119148	20320	20321	20224	3026-P	5
E3	118720	BN	10			E9	118276	BN	10			7-Way	A	SUV6	119148	20252				3026-P	5
E3	118720	BN	10			E9	118276	BN	10			7-Way	A	SUV6	119148	20252					
E10	118270	BN	20	7.5		E16	118271	BN	20			7-Way	A,E	SUV1,2	119191	119148	20320	20321	20224	3026-P	5
													A	PU1,2	119148	20252	20320	20321	20224		
E3	118315	BN	5	7.5									A	PU3	119148	20252	20320	20321	20224		
E3	118315	BN	5	7.5									A	PU3	119148	20252	20320	20321	20224		
E3	118315	BN	5	7.5									A	PU3	119148	20252	20320	20321	20224		
E3	118315	BN	5	7.5									A	PU1,2	119148	20252	20320	20321	20224		
E3	118315	BN	5	7.5									A	PU3	119148	20252	20320	20321	20224		
E3	118315	BN	5	7.5									A	PU3	119148	20252	20320	20321	20224		
E3	118315	BN	5	7.5									A	PU3	119148	20252	20320	20321	20224		

A 2 wire system.
B 3 wire system. Converter required.
BN Exterior mounted plug on some or all models. May require an aftermarket electrical mounting box or bracket. (Sold separately)
CH T-One is equipped with circuit protected ModuLite® module.
E ModuLite® required.
HG T-One incorporates taillight converter.
N DO NOT cut or splice vehicle wiring. Only use approved T-One or see auto dealer for trailer tow wiring kit.
RD For vehicles equipped with factory tow package may require additional components or may be used as a replacement harness.

RT3 Round Tube Class III 2"
RT4 Round Tube Class IV 2"
SQ1 Square Tube Class I
SQ3 Square Tube Class III
SQ4 Square Tube Class IV
SQ5 Square Tube Class V

MODEL / STYLE	YEAR	TRAILER HITCHES									
		PC	REC TYPE	REC SIZE	PART NO.	NO DRILL	FOOTNOTES	OPTIONAL DRAWBAR	WC (LBS.)	WD (LBS.)	IN
GMC (Continued)											
C3500 w/10" Deep Drop Bumper	88-00	49	SQ4	2	41528	0	FS,J		600/6,000	1,000/10,000	20
C3500 w/Aftermarket Roll Pan	88-00	37	SQ3	2	41522		CO,HK		500/5,000	550/5,500	40
C4500 Topkick Cab & Chassis, w/34" Wide Frames	03-09	55	SQ5	2	41947		@		1,600/15,000	1,600/16,000	35
C5500 Topkick Cab & Chassis, w/34" Wide Frames	03-09	55	SQ5	2	41947		@		1,600/15,000	1,600/16,000	35
C6500 Topkick Cab & Chassis, w/34" Wide Frames	99-09	55	SQ5	2	41947		@		1,600/15,000	1,600/16,000	35
C7500 Topkick Cab & Chassis, w/34" Wide Frames	99-09	55	SQ5	2	41947		@		1,600/15,000	1,600/16,000	35
Canyon	04-12	23	SQ4	2	75607	0	CP,GP		600/6,000	750/7,500	25
Canyon w/Factory 7-Way	04-12										
Canyon	15-19	34	RT4	2	75948	0	HM,AA,V,SO,TZ		800/6,000	800/8,000	35
		30	SQ4	2	76004	0	HM,AA,V,SO,TZ		800/8,000	1,000/10,000	35
Envoy w/Factory 7-Way	02-09										
Jimmy Downsize	95-98	32	SQ2	1-1/4	36244	0	FP,GP,KK	36051	300/3,500		15
		21	RT3	2	75079	0	FP,KK,SD		400/4,000	600/6,000	15
Jimmy Downsize	99-01	32	SQ2	1-1/4	36244	0	FP,GP,KK	36051	300/3,500		15
		21	RT3	2	75079	0	FP,KK,SD		400/4,000	600/6,000	15
Jimmy Downsize, w/Factory 7-Way	99-01										
Jimmy Downsize	02-05	32	SQ2	1-1/4	36244	0	FP,GP,KK	36051	300/3,500		15
		21	RT3	2	75079	0	FP,KK,SD		400/4,000	600/6,000	15
K1500	88-99	49	RT3	2	37133				500/5,000	750/7,500	40
		35	SQ3	2	75033	0	HM,J		500/5,000	800/8,000	20
		25	SQ3	2	75099	0	GP		500/5,000	800/8,000	20
		44	SQ4	2	41524	0	GP		600/6,000	1,000/10,000	20
		38	SQ4	2	41525†	0	HM,J		600/6,000	1,000/10,000	20
		54	RT4	2	37130				700/7,000	1,200/12,000	40
		45	SQ5	2	41901		@,DB,GP,SN		1,000/10,000	1,300/13,000	30
K1500 w/10" Deep Drop Bumper	88-99	49	SQ4	2	41528	0	FS,J		600/6,000	1,000/10,000	20
K1500 w/34" Wide Frames	88-99	50	SQ5	2	41938		@,CC		1,200/12,000	1,500/15,000	40
		55	SQ5	2	41947		@		1,600/15,000	1,600/16,000	35
K1500 w/Aftermarket Roll Pan	88-99	37	SQ3	2	41522		CO,HK		500/5,000	550/5,500	40
K2500	88-00	49	RT3	2	37133				500/5,000	750/7,500	40
		35	SQ3	2	75033	0	HM,J		500/5,000	800/8,000	20
		25	SQ3	2	75099	0	GP		500/5,000	800/8,000	20
		44	SQ4	2	41524	0	GP		600/6,000	1,000/10,000	20
		38	SQ4	2	41525†	0	HM,J		600/6,000	1,000/10,000	20
		54	RT4	2	37130				700/7,000	1,200/12,000	40
		45	SQ5	2	41901		@,DB,GP,SN		1,000/10,000	1,300/13,000	30
		59	SQ5	2-1/2	45506		#		1,200/12,000	1,700/14,000	45
K2500 w/10" Deep Drop Bumper	88-00	49	SQ4	2	41528	0	FS,J		600/6,000	1,000/10,000	20
K2500 w/34" Wide Frames	88-00	50	SQ5	2	41938		@,CC		1,200/12,000	1,500/15,000	40
		55	SQ5	2	41947		@		1,600/15,000	1,600/16,000	35
K2500 w/Aftermarket Roll Pan	88-00	37	SQ3	2	41522		CO,HK		500/5,000	550/5,500	40

Titan hitches require use of a 2-1/2" shank Titan ball mount.

@ Ultra Frame ball mount must be used to achieve maximum weight carrying rating.

AA Requires temporary removal of bumper during installation.

CC Requires minimum of 19 in. from end of frame rail to spring shackle bracket.

CO Will not fit 8 ft. 2500/3500 Series with heavy-duty suspension or four door Crew Cab.

CP Fits all models without factory installed receiver.

DB Will not fit 6 ft. bed pickups.

FP Spare tire repositioning and/or modification of spare tire carrier may be required.

FS Includes 2 & 4 WD models with heavy duty suspension.

GP Hitch crosstube concealed behind bumper.

HK Under vehicle spare tire stowage may be retained with installation of an aftermarket spare tire repositioner. Cutting of rollpan in license plate area required for receiver tube access. Does not fit with bumper.

HM Hitch crosstube is visible beneath bumper.

J Under vehicle spare tire stowage is retained.

KK When installing on a vehicle originally equipped with an OEM hitch. OEM bumper brackets must be purchased and installed prior to new hitch installation.

SD Hitches produced before 07/21/06 are rated at 350/3500 WC.

SN Hitches produced before 04/28/08 are rated at 1000/10000 WC & 1200/12000 WD.

SO With this hitch installed the step bumper is no longer able to be used as a towing point.

TZ Requires replacement of the impact structure with hitch.

V For vehicles with factory installed step bumpers only.

T-ONE						TOW HARNESS						4-FLAT WIRING				REQ. 4 FLAT WIRING		7-WAY HARDWARE	BRAKE CONTROL HARNESS	IN
PC	T-ONE	FN	IN	AMP	CP	PC	TOW HARN	FN	IN	AMP	CP	TYPE	ELEC	POS	CHOICE 1	CHOICE 2	6-WAY ADAPTER			
GMC (Continued)																				
E3	118315	BN	5	7.5									A	PU3	119148	20252	20320	20321	20224	
E3	118315	BN	5	7.5									A	PU3	119148	20252	20320	20321	20224	
													A		119148	20252				
													A		119148	20252				
													A		119148	20252				
E10	118301	BN,CG	10	2.1,5	X	E8	118384	BN,RD	5	7.5		4-Flat	B	PU3	119130	119178	20320	20321	20224	
							74682	RD	10			Both	H	PU3	119148	20252				
							8551511	RD	5			7-Way								
							85219	RD	5			7-Way	A	PU3	119148	20252	20320	20321	20224	
						E8	118384	BN,RD	5	7.5		4-Flat	H	SUV6	119148	20252				
							74682	RD	10			Both								
							8551511	RD	5			7-Way	A	SUV7	119148	20252	20320	20321	20224	
							85219	RD	5			7-Way								
													A	SUV7	119148	20252	20320	20321	20224	
						E8	118384	BN,RD	5	7.5		4-Flat	A	SUV7	119148	20252	20320	20321	20224	
							74682	RD	10			Both	A	SUV6	119148	20252				
							85219	RD	5			7-Way								
							8551511	RD	5			7-Way	A	SUV7	119148	20252	20320	20321	20224	
E3	118315	BN	5	7.5									A	PU3	119148	20252	20320	20321	20224	
E3	118315	BN	5	7.5									A	PU1,2	119148	20252	20320	20321	20224	
E3	118315	BN	5	7.5									A	PU3	119148	20252	20320	20321	20224	
E3	118315	BN	5	7.5									A	PU3	119148	20252	20320	20321	20224	
E3	118315	BN	5	7.5									A	PU3	119148	20252	20320	20321	20224	
E3	118315	BN	5	7.5									A	PU1,2	119148	20252	20320	20321	20224	
E3	118315	BN	5	7.5									A	PU3	119148	20252	20320	20321	20224	

A 2 wire system.
B 3 wire system. Converter required.
BN Exterior mounted plug on some or all models. May require an aftermarket electrical mounting box or bracket. (Sold separately)

CG T-One incorporates circuit protected taillight converter.
H 3 wire system with OEM standard 2 wire harness.
RD For vehicles equipped with factory tow package may require additional components or may be used as a replacement harness.

RT3 Round Tube Class III 2"
RT4 Round Tube Class IV 2"
SQ2 Square Tube Class II
SQ3 Square Tube Class III
SQ4 Square Tube Class IV
SQ5 Square Tube Class V

MODEL / STYLE	YEAR	TRAILER HITCHES									
		PC	REC TYPE	REC SIZE	PART NO.	NO DRILL	FOOTNOTES	OPTIONAL DRAWBAR	WC (LBS.)	WD (LBS.)	IN
GMC (Continued)											
K3500	88-00	49	RT3	2	37133				500/5,000	750/7,500	40
		35	SQ3	2	75033	0	HM,J		500/5,000	800/8,000	20
		25	SQ3	2	75099	0	GP		500/5,000	800/8,000	20
		44	SQ4	2	41524	0	GP		600/6,000	1,000/10,000	20
		38	SQ4	2	415251	0	HM,J		600/6,000	1,000/10,000	20
		54	RT4	2	37130				700/7,000	1,200/12,000	40
		45	SQ5	2	41901		@,DB,GP,SN		1,000/10,000	1,300/13,000	30
		59	SQ5	2-1/2	45506		#	1,200/12,000	1,700/14,000	45	
K3500 w/10" Deep Drop Bumper	88-00	49	SQ4	2	41528	0	FS,J		600/6,000	1,000/10,000	20
K3500 w/34" Wide Frames	88-00	50	SQ5	2	41938		@,CC		1,200/12,000	1,500/15,000	40
		55	SQ5	2	41947		@		1,600/15,000	1,600/16,000	35
K3500 w/Aftermarket Roll Pan	88-00	37	SQ3	2	41522		CO,HK		500/5,000	550/5,500	40
Safari Extended Body	90-05	33	SQ2	1-1/4	36197	0	CS,HM	36051	300/3,500		30
		34	SQ2	1-1/4	36198	0	CS,GP	36053	300/3,500		30
		33	SQ3	2	75122	0	CS,GP		300/3,500	600/6,000	30
		50	SQ3	2	37136		AF		500/5,000	600/6,000	65
Savana 1500	96-99	31	SQ2	1-1/4	36206	0	HM	36053	300/3,500		15
		50	SQ3	2	37136		HM		500/5,000	600/6,000	30
		20	SQ3	2	75189	0	HM		500/5,000	750/7,500	15
		33	SQ4	2	41521	0	HM		600/6,000	1,000/10,000	15
		42	SQ5	2	41946		@,HM		1,500/10,000	1,300/13,000	35
Savana 1500	00-02	31	SQ2	1-1/4	36206	0	HM	36053	300/3,500		15
		50	SQ3	2	37136		HM		500/5,000	600/6,000	30
		20	SQ3	2	75189	0	HM		500/5,000	750/7,500	15
		33	SQ4	2	41521	0	HM		600/6,000	1,000/10,000	15
		42	SQ5	2	41946		@,HM		1,500/10,000	1,300/13,000	35
Savana 1500	03	31	SQ2	1-1/4	36206	0	HM	36053	300/3,500		15
		50	SQ3	2	37136		HM		500/5,000	600/6,000	30
		20	SQ3	2	75189	0	HM		500/5,000	750/7,500	15
		33	SQ4	2	41521	0	HM		600/6,000	1,000/10,000	15
		42	SQ5	2	41946		@,HM		1,500/10,000	1,300/13,000	35
Savana 1500	04-14	31	SQ2	1-1/4	36206	0	HM	36053	300/3,500		15
		50	SQ3	2	37136		HM		500/5,000	600/6,000	30
		20	SQ3	2	75189	0	HM		500/5,000	750/7,500	15
		33	SQ4	2	41521	0	HM		600/6,000	1,000/10,000	15
		42	SQ5	2	41946		@,HM		1,500/10,000	1,300/13,000	35
Savana 2500	96-99	31	SQ2	1-1/4	36206	0	HM	36053	300/3,500		15
		50	SQ3	2	37136		HM		500/5,000	600/6,000	30
		20	SQ3	2	75189	0	HM		500/5,000	750/7,500	15
		33	SQ4	2	41521	0	HM		600/6,000	1,000/10,000	15
		42	SQ5	2	41946		@,HM		1,500/10,000	1,300/13,000	35
		52	SQ5	2-1/2	45507	0	#,HM		1,200/12,000	1,700/14,000	45
Savana 2500	00-02	31	SQ2	1-1/4	36206	0	HM	36053	300/3,500		15
		50	SQ3	2	37136		HM		500/5,000	600/6,000	30
		20	SQ3	2	75189	0	HM		500/5,000	750/7,500	15
		33	SQ4	2	41521	0	HM		600/6,000	1,000/10,000	15
		42	SQ5	2	41946		@,HM		1,500/10,000	1,300/13,000	35
		52	SQ5	2-1/2	45507	0	#,HM		1,200/12,000	1,700/14,000	45

Titan hitches require use of a 2-1/2" shank Titan ball mount.
 @ Ultra Frame ball mount must be used to achieve maximum weight carrying rating.
 AF Hitch is ONLY rated for Weight Carrying at 3500 lbs. GTW / 350 lbs. TW and DO NOT use Weight Distribution Spring Bars for this Specific Vehicle. Except for long bed pickups.
 CC Requires minimum of 19 in. from end of frame rail to spring shackle bracket.
 CO Will not fit 8 ft. 2500/3500 Series with heavy-duty suspension or four door Crew Cab.
 CS Will fit with full-size spare tire stowed under vehicle.
 DB Will not fit 6 ft. bed pickups.

FS Includes 2 & 4 WD models with heavy duty suspension.
 GP Hitch crosstube concealed behind bumper.
 HK Under vehicle spare tire stowage may be retained with installation of an aftermarket spare tire repositioner. Cutting of rollpan in license plate area required for receiver tube access. Does not fit with bumper.
 HM Hitch crosstube is visible beneath bumper.
 J Under vehicle spare tire stowage is retained.
 SN Hitches produced before 04/28/08 are rated at 1000/10000 WC & 1200/12000 WD.

T-ONE					TOW HARNESS							4-FLAT WIRING				REQ. 4 FLAT WIRING		7-WAY HARDWIRE	BRAKE CONTROL HARNESS	IN
PC	T-ONE	FN	IN	AMP	CP	PC	TOW HARN	FN	IN	AMP	CP	TYPE	ELEC	POS	CHOICE 1	CHOICE 2	6-WAY ADAPTER			
GMC (Continued)																				
E3	118315	BN	5	7.5									A	PU3	119148	20252	20320	20321	20224	
E3	118315	BN	5	7.5									A	PU3	119148	20252	20320	20321	20224	
													A	PU1,2	119148	20252	20320	20321	20224	
E3	118315	BN	5	7.5									A	PU3	119148	20252	20320	20321	20224	
													A	SUV4	119148	20252	20320	20321	20224	
E8	118335	HG	10	2.1,5		E1	118240	RD	5	7.5		4-Flat	B	SUV3,4	119130	119178	20320	20321	20224	
E8	118377	HG	10	2.1,5		E1	118240	RD	5	7.5		4-Flat	B	SUV3,4	119130	119178	20320	20321	20224	
E5	118392		20	7.5		E1	118240	RD	5	7.5		4-Flat	A	SUV3,4	119148	20252	20320	20321	20224	
E5	118392		20	7.5									A	SUV3,4	119148	20252	20320	20321	20224	
E8	118335	HG	10	2.1,5		E1	118240	RD	5	7.5		4-Flat	B	SUV3,4	119130	119178	20320	20321	20224	
E8	118377	HG	10	2.1,5		E1	118240	RD	5	7.5		4-Flat	B	SUV3,4	119130	119178	20320	20321	20224	

A 2 wire system.
B 3 wire system. Converter required.
BN Exterior mounted plug on some or all models. May require an aftermarket electrical mounting box or bracket. (Sold separately)

HG T-One incorporates taillight converter.
RD For vehicles equipped with factory tow package may require additional components or may be used as a replacement harness.

RT3 Round Tube Class III 2"
RT4 Round Tube Class IV 2"
SQ2 Square Tube Class II
SQ3 Square Tube Class III
SQ4 Square Tube Class IV
SQ5 Square Tube Class V

MODEL / STYLE	YEAR	TRAILER HITCHES									
		PC	REC TYPE	REC SIZE	PART NO.	NO DRILL	FOOTNOTES	OPTIONAL DRAWBAR	WC (LBS.)	WD (LBS.)	IN
GMC (Continued)											
Savana 2500	03	31	SQ2	1-1/4	36206	0	HM	36053	300/3,500		15
		50	SQ3	2	37136		HM		500/5,000	600/6,000	30
		20	SQ3	2	75189	0	HM		500/5,000	750/7,500	15
		33	SQ4	2	41521	0	HM		600/6,000	1,000/10,000	15
		42	SQ5	2	41946		@,HM		1,500/10,000	1,300/13,000	35
		52	SQ5	2-1/2	45507	0	#,HM		1,200/12,000	1,700/14,000	45
Savana 2500	04-17	31	SQ2	1-1/4	36206	0	HM	36053	300/3,500		15
		50	SQ3	2	37136		HM		500/5,000	600/6,000	30
		20	SQ3	2	75189	0	HM		500/5,000	750/7,500	15
		33	SQ4	2	41521	0	HM		600/6,000	1,000/10,000	15
		42	SQ5	2	41946		@,HM		1,500/10,000	1,300/13,000	35
		52	SQ5	2-1/2	45507	0	#,HM		1,200/12,000	1,700/14,000	45
Savana 2500	18										
Savana 3500	96-99	31	SQ2	1-1/4	36206	0	HM	36053	300/3,500		15
		50	SQ3	2	37136		HM		500/5,000	600/6,000	30
		20	SQ3	2	75189	0	HM		500/5,000	750/7,500	15
		33	SQ4	2	41521	0	HM		600/6,000	1,000/10,000	15
		42	SQ5	2	41946		@,HM		1,500/10,000	1,300/13,000	35
		52	SQ5	2-1/2	45507	0	#,HM		1,200/12,000	1,700/14,000	45
Savana 3500	00-02	31	SQ2	1-1/4	36206	0	HM	36053	300/3,500		15
		50	SQ3	2	37136		HM		500/5,000	600/6,000	30
		20	SQ3	2	75189	0	HM		500/5,000	750/7,500	15
		33	SQ4	2	41521	0	HM		600/6,000	1,000/10,000	15
		42	SQ5	2	41946		@,HM		1,500/10,000	1,300/13,000	35
		52	SQ5	2-1/2	45507	0	#,HM		1,200/12,000	1,700/14,000	45
Savana 3500	03	31	SQ2	1-1/4	36206	0	HM	36053	300/3,500		15
		50	SQ3	2	37136		HM		500/5,000	600/6,000	30
		20	SQ3	2	75189	0	HM		500/5,000	750/7,500	15
		33	SQ4	2	41521	0	HM		600/6,000	1,000/10,000	15
		42	SQ5	2	41946		@,HM		1,500/10,000	1,300/13,000	35
		52	SQ5	2-1/2	45507	0	#,HM		1,200/12,000	1,700/14,000	45
Savana 3500	04-17	31	SQ2	1-1/4	36206	0	HM	36053	300/3,500		15
		50	SQ3	2	37136		HM		500/5,000	600/6,000	30
		20	SQ3	2	75189	0	HM		500/5,000	750/7,500	15
		33	SQ4	2	41521	0	HM		600/6,000	1,000/10,000	15
		42	SQ5	2	41946		@,HM		1,500/10,000	1,300/13,000	35
		52	SQ5	2-1/2	45507	0	#,HM		1,200/12,000	1,700/14,000	45
Savana 3500	18										
Sierra Denali HD 6.6 ft. Bed, w/Factory 7-Way	11-13										
Sierra 1500	99-02	49	RT3	2	37133	0			500/5,000	750/7,500	25
		39	SQ4	2	41534	0			600/6,000	1,200/12,000	20
		54	RT4	2	37130	0			700/7,000	1,200/12,000	25
		30	RT4	2	75362	0	JL		900/6,000	900/8,000	15
		22	RT4	2	75521	0	JL,SZ		900/6,000	1,050/10,500	15
		50	SQ5	2	41932	0	@,HM,JL		1,200/12,000	1,400/14,000	20
Sierra 1500 w/Factory 7-Way	99-12										

Titan hitches require use of a 2-1/2" shank Titan ball mount.

@ Ultra Frame ball mount must be used to achieve maximum weight carrying rating.

HM Hitch cross-tube is visible beneath bumper.

JL Installation requires OEM bumper and brackets.

SZ Hitches produced before 03/10/11 are rated at 600/6000 WC.

T-ONE						TOW HARNESS						4-FLAT WIRING				REQ. 4 FLAT WIRING		7-WAY HARDWARE	BRAKE CONTROL HARNESS	IN	
PC	T-ONE	FN	IN	AMP	CP	PC	TOW HARN	FN	IN	AMP	CP	TYPE	ELEC	POS	CHOICE 1	CHOICE 2	6-WAY ADAPTER				7-WAY ADAPTER
GMC (Continued)																					
E5	118392		20	7.5		E1	118240	RD	5	7.5		4-Flat	A	SUV3,4	119148	20252	20320	20321	20224		
E5	118392		20	7.5									A	SUV3,4	119148	20252	20320	20321	20224		
E5	118392		20	7.5									A	SUV3,4	119148	20252	20320	20321	20224		
E8	118335	HG	10	2.1,5		E1	118240	RD	5	7.5		4-Flat	B	SUV3,4	119130	119178	20320	20321	20224		
E8	118377	HG	10	2.1,5		E1	118240	RD	5	7.5		4-Flat	B	SUV3,4	119130	119178	20320	20321	20224		
E5	118392		20	7.5		E1	118240	RD	5	7.5		4-Flat	A	SUV3,4	119148	20252	20320	20321	20224		
E5	118392		20	7.5									A	SUV3,4	119148	20252	20320	20321	20224		
E5	118392		20	7.5									A	SUV3,4	119148	20252	20320	20321	20224		
							74682 8551511 85219	RD RD RD	10 5			Both 7-Way 7-Way	A	PU3	119148	20252					
						E8	118384	BN,RD	5	7.5		4-Flat	A	PU3	119148	20252	20320	20321	20224	3025-P	5
							74682 85219 8551511	RD RD RD	10 5			Both 7-Way 7-Way	H	PU3	119148	20252					

A 2 wire system.
B 3 wire system. Converter required.
BN Exterior mounted plug on some or all models. May require an aftermarket electrical mounting box or bracket. (Sold separately)

H 3 wire system with OEM standard 2 wire harness.
HG T-One incorporates taillight converter.
RD For vehicles equipped with factory tow package may require additional components or may be used as a replacement harness.

RT3 Round Tube Class III 2"
RT4 Round Tube Class IV 2"
SQ2 Square Tube Class II
SQ3 Square Tube Class III
SQ4 Square Tube Class IV
SQ5 Square Tube Class V

MODEL / STYLE	YEAR	TRAILER HITCHES									
		PC	REC TYPE	REC SIZE	PART NO.	NO DRILL	FOOTNOTES	OPTIONAL DRAWBAR	WC (LBS.)	WD (LBS.)	IN
GMC (Continued)											
Sierra 1500 (Classic)	03-07	49	RT3	2	37133	0			500/5,000	750/7,500	25
		39	SQ4	2	41534	0			600/6,000	1,200/12,000	20
		54	RT4	2	37130	0			700/7,000	1,200/12,000	25
		30	RT4	2	75362	0	JL		900/6,000	900/8,000	15
		22	RT4	2	75521	0	JL,SZ		900/6,000	1,050/10,500	15
		50	SQ5	2	41932	0	@,HM,JL		1,200/12,000	1,400/14,000	20
Sierra 1500	07-13	30	RT4	2	75362	0	JL		900/6,000	900/8,000	15
		22	RT4	2	75521	0	JL,SZ		900/6,000	1,050/10,500	15
Sierra 1500 LD (Old Body Style)	14-19	33	RT4	2	75866	0	HM,JL		900/6,000	1,200/12,000	20
		25	SQ4	2	76016	0	GP,JL		900/6,000	1,000/10,000	25
Sierra 1500 (New Body Style)	19										
Sierra 1500 HD	01-02	49	RT3	2	37133	0			500/5,000	750/7,500	25
		39	SQ4	2	41534	0			600/6,000	1,200/12,000	20
		54	RT4	2	37130	0			700/7,000	1,200/12,000	25
		30	RT4	2	75362	0	JL		900/6,000	900/8,000	15
		22	RT4	2	75521	0	JL,SZ		900/6,000	1,050/10,500	15
		50	SQ5	2	41932	0	@,HM,JL		1,200/12,000	1,400/14,000	20
Sierra 1500 HD w/Factory 7-Way	01-07										
Sierra 1500 HD	03	49	RT3	2	37133	0			500/5,000	750/7,500	25
		39	SQ4	2	41534	0			600/6,000	1,200/12,000	20
		54	RT4	2	37130	0			700/7,000	1,200/12,000	25
		30	RT4	2	75362	0	JL		900/6,000	900/8,000	15
		22	RT4	2	75521	0	JL,SZ		900/6,000	1,050/10,500	15
		50	SQ5	2	41932	0	@,HM,JL		1,200/12,000	1,400/14,000	20
Sierra 1500 HD (Classic)	05-07	49	RT3	2	37133	0			500/5,000	750/7,500	25
		39	SQ4	2	41534	0			600/6,000	1,200/12,000	20
		54	RT4	2	37130	0			700/7,000	1,200/12,000	25
		30	RT4	2	75362	0	JL		900/6,000	900/8,000	15
		22	RT4	2	75521	0	JL,SZ		900/6,000	1,050/10,500	15
		50	SQ5	2	41932	0	@,HM,JL		1,200/12,000	1,400/14,000	20
Sierra 2500	99-02	49	RT3	2	37133	0			500/5,000	750/7,500	25
		39	SQ4	2	41534	0			600/6,000	1,200/12,000	20
		54	RT4	2	37130	0			700/7,000	1,200/12,000	25
		30	RT4	2	75362	0	JL		900/6,000	900/8,000	15
		22	RT4	2	75521	0	JL,SZ		900/6,000	1,050/10,500	15
		50	SQ5	2	41932	0	@,HM,JL		1,200/12,000	1,400/14,000	20
		58	SQ5	2-1/2	45512†	0	#		1,200/12,000	1,700/14,000	20
Sierra 2500 w/Factory 7-Way	99-04										
Sierra 2500	03-04	49	RT3	2	37133	0			500/5,000	750/7,500	25
		39	SQ4	2	41534	0			600/6,000	1,200/12,000	20
		54	RT4	2	37130	0			700/7,000	1,200/12,000	25
		30	RT4	2	75362	0	JL		900/6,000	900/8,000	15
		22	RT4	2	75521	0	JL,SZ		900/6,000	1,050/10,500	15
		50	SQ5	2	41932	0	@,HM,JL		1,200/12,000	1,400/14,000	20
		58	SQ5	2-1/2	45512†	0	#		1,200/12,000	1,700/14,000	20

Titan hitches require use of a 2-1/2" shank Titan ball mount.
 @ Ultra Frame ball mount must be used to achieve maximum weight carrying rating.
 GP Hitch cross-tube concealed behind bumper.

HM Hitch cross-tube is visible beneath bumper.
 JL Installation requires OEM bumper and brackets.
 SZ Hitches produced before 03/10/11 are rated at 600/6000 WC.

T-ONE						TOW HARNESS						4-FLAT WIRING				REQ. 4 FLAT WIRING		7-WAY HARDWIRE	BRAKE CONTROL HARNESS	IN	
PC	T-ONE	FN	IN	AMP	CP	PC	TOW HARN	FN	IN	AMP	CP	TYPE	ELEC	POS	CHOICE 1	CHOICE 2	6-WAY ADAPTER				7-WAY ADAPTER
GMC (Continued)																					
						E8	118384	BN,RD	5	7.5		4-Flat	A	PU3	119148	20252	20320	20321	20224	3015-P	5
E8	118384	BN	5	7.5									A	PU3	119148	20252	20320	20321	20224		
E8	118384		5	7.5									A	PU3	119148	20252	20320	20321	20224	3015-P	5
													A	PU3	119148	20252	20320	20321	20224	85133	
						E8	118384	BN,RD	5	7.5		4-Flat	A	PU3	119148	20252	20320	20321	20224	3025-P	5
							8551511 85219 74682	RD RD RD	5 10			7-Way 7-Way Both	H	PU3	119148	20252					
						E8	118384	BN,RD	5	7.5		4-Flat	A	PU3	119148	20252	20320	20321	20224	3015-P	5
						E8	118384	BN,RD	5	7.5		4-Flat	A	PU3	119148	20252	20320	20321	20224	3015-P	5
						E8	118384	BN,RD	5	7.5		4-Flat	A	PU3	119148	20252	20320	20321	20224	3025-P	5
							85219 8551511 74682	RD RD RD	5 10			7-Way 7-Way Both	H	PU3	119148	20252					
						E8	118384	BN,RD	5	7.5		4-Flat	A	PU3	119148	20252	20320	20321	20224	3015-P	5

A 2 wire system.

BN Exterior mounted plug on some or all models. May require an aftermarket electrical mounting box or bracket. (Sold separately)

H 3 wire system with OEM standard 2 wire harness.

RD For vehicles equipped with factory tow package may require additional components or may be used as a replacement harness.

RT3 Round Tube Class III 2"

RT4 Round Tube Class IV 2"

SQ4 Square Tube Class IV

SQ5 Square Tube Class V

MODEL / STYLE	YEAR	TRAILER HITCHES									
		PC	REC TYPE	REC SIZE	PART NO.	NO DRILL	FOOTNOTES	OPTIONAL DRAWBAR	WC (LBS.)	WD (LBS.)	IN
GMC (Continued)											
Sierra 2500 HD	01-02	46	SQ4	2	41544	0	HM,SA		600/6,000	1,200/12,000	20
		34	RT4	2	75550	0	CS,FS,JLLT		600/6,000	1,100/11,000	20
		37	SQ5	2	41944	0	@,CS,FS,HM,LT		1,950/13,000	1,600/16,000	25
		58	SQ5	2-1/2	45517	0	#,CS,FS,LT		1,300/13,000	1,700/17,000	25
Sierra 2500 HD 8 ft. Bed	01-02	60	SQ5	2-1/2	45519	0	#,CS,FS,LT		2,000/18,000	2,500/18,000	25
Sierra 2500 HD w/Factory 7-Way	01-19										
Sierra 2500 HD (Classic)	03-07	46	SQ4	2	41544	0	HM,SA		600/6,000	1,200/12,000	20
		34	RT4	2	75550	0	CS,FS,JLLT		600/6,000	1,100/11,000	20
		37	SQ5	2	41944	0	@,CS,FS,HM,LT		1,950/13,000	1,600/16,000	25
		58	SQ5	2-1/2	45517	0	#,CS,FS,LT		1,300/13,000	1,700/17,000	25
Sierra 2500 HD 8 ft. Bed	03-06	60	SQ5	2-1/2	45519	0	#,CS,FS,LT		2,000/18,000	2,500/18,000	25
Sierra 2500 HD	07-10	34	RT4	2	75550	0	CS,FS,JLLT		600/6,000	1,100/11,000	20
		37	SQ5	2	41944	0	@,CS,FS,HM,LT		1,950/13,000	1,600/16,000	25
		58	SQ5	2-1/2	45517	0	#,CS,FS,LT		1,300/13,000	1,700/17,000	25
Sierra 2500 HD 8 ft. Bed	07-10	60	SQ5	2-1/2	45519	0	#,CS,FS,LT		2,000/18,000	2,500/18,000	25
Sierra 2500 HD 8 ft. Bed (Classic)	07	60	SQ5	2-1/2	45519	0	#,CS,FS,LT		2,000/18,000	2,500/18,000	25
Sierra 2500 HD	11-14	43	SQ4	2	75707	0	CS,FS,GP,JL,LT		800/8,000	1,200/12,000	20
		50	SQ5	2	41942	0	@,CS,FS,GP,JL,KH,LT		1,500/15,000	1,600/16,000	20
		67	SQ5	2-1/2	45510	0	#,CS,FS,HM,JL,KH,LT		2,000/18,000	2,500/18,000	60
Sierra 2500 HD	15-19	42	SQ4	2	75906	0	HM,JL		1,200/8,000	1,200/12,000	30
		53	SQ5	2	41950	0	@,CS,FS,GP,JL,KH,LT		1,700/15,000	1,700/17,000	60
		57	SQ5	2-1/2	45511	0	#,HM		2,700/20,000	2,700/20,000	60
Sierra 3500	01-02	46	SQ4	2	41544	0	HM,SA		600/6,000	1,200/12,000	20
		34	RT4	2	75550	0	CS,FS,JLLT		600/6,000	1,100/11,000	20
		37	SQ5	2	41944	0	@,CS,FS,HM,LT		1,950/13,000	1,600/16,000	25
		58	SQ5	2-1/2	45517	0	#,CS,FS,LT		1,300/13,000	1,700/17,000	25
		60	SQ5	2-1/2	45519	0	#,CS,FS,LT		2,000/18,000	2,500/18,000	25
Sierra 3500 Cab & Chassis, w/34" Wide Frames (Classic)	01-07	29	SQ5	2	41936		@		1,200/12,000		30
		50	SQ5	2	41938		@,CC		1,200/12,000	1,500/15,000	40
		55	SQ5	2	41947		@		1,600/15,000	1,600/16,000	35
Sierra 3500 w/Factory 7-Way	01-07										
Sierra 3500 (Classic)	03-07	34	RT4	2	75550	0	CS,FS,JLLT		600/6,000	1,100/11,000	20
Sierra 3500 (Classic)	03-07	46	SQ4	2	41544	0	HM,SA		600/6,000	1,200/12,000	20
		37	SQ5	2	41944	0	@,CS,FS,HM,LT		1,950/13,000	1,600/16,000	25
		58	SQ5	2-1/2	45517	0	#,CS,FS,LT		1,300/13,000	1,700/17,000	25
		60	SQ5	2-1/2	45519	0	#,CS,FS,LT		2,000/18,000	2,500/18,000	25
Sierra 3500 HD	07-10	34	RT4	2	75550	0	CS,FS,JLLT		600/6,000	1,100/11,000	20
		37	SQ5	2	41944	0	@,CS,FS,HM,LT		1,950/13,000	1,600/16,000	25
		58	SQ5	2-1/2	45517	0	#,CS,FS,LT		1,300/13,000	1,700/17,000	25
		60	SQ5	2-1/2	45519	0	#,CS,FS,LT		2,000/18,000	2,500/18,000	25
Sierra 3500 HD	07-19										
Sierra 3500 HD Cab & Chassis, w/34" Wide Frames	07-20	29	SQ5	2	41936		@		1,200/12,000		30
		50	SQ5	2	41938		@,CC		1,200/12,000	1,500/15,000	40
		55	SQ5	2	41947		@		1,600/15,000	1,600/16,000	35
Sierra 3500 HD	11-14	43	SQ4	2	75707	0	CS,FS,GP,JL,LT		800/8,000	1,200/12,000	20
		50	SQ5	2	41942	0	@,CS,FS,GP,JL,KH,LT		1,500/15,000	1,600/16,000	20
		67	SQ5	2-1/2	45510	0	#,CS,FS,HM,JL,KH,LT		2,000/18,000	2,500/18,000	60

Titan hitches require use of a 2-1/2" shank Titan ball mount.
 @ Ultra Frame ball mount must be used to achieve maximum weight carrying rating.
 CC Requires minimum of 19 in. from end of frame rail to spring shackle bracket.
 CS Will fit with full-size spare tire stowed under vehicle.
 FS Includes 2 & 4 WD models with heavy duty suspension.
 GP Hitch crosstube concealed behind bumper.

HM Hitch crosstube is visible beneath bumper.
 JL Installation requires OEM bumper and brackets.
 KH Minor heat shield modification may be required.
 LT Requires removal of factory hitch if equipped.
 SA Requires drilling on 6 ft. bed models.

T-ONE					TOW HARNESS							4-FLAT WIRING				REQ. 4 FLAT WIRING		7-WAY HARDWARE	BRAKE CONTROL HARNESS	IN	
PC	T-ONE	FN	IN	AMP	CP	PC	TOW HARN	FN	IN	AMP	CP	TYPE	ELEC	POS	CHOICE 1	CHOICE 2	6-WAY ADAPTER				7-WAY ADAPTER
GMC (Continued)																					
						E8	118384	BN,RD	5	7.5		4-Flat	A	PU3	119148	20252	20320	20321	20224	3025-P	5
						E8	118384	BN,RD	5	7.5		4-Flat	A	PU3	119148	20252	20320	20321	20224	3025-P	5
							8551511 85219 74682	RD RD RD	5 5 10			7-Way 7-Way Both	H	PU3	119148	20252					
						E8	118384	BN,RD	5	7.5		4-Flat	A	PU3	119148	20252	20320	20321	20224	3015-P	5
						E8	118384	BN,RD	5	7.5		4-Flat	A	PU3	119148	20252	20320	20321	20224	3015-P	5
E8	118384	BN	5	7.5									A	PU3	119148	20252	20320	20321	20224		
E8	118384	BN	5	7.5									A	PU3	119148	20252	20320	20321	20224		
E8	118384	BN	5	7.5		E8	118384	BN,RD	5	7.5		4-Flat	A	PU3	119148	20252	20320	20321	20224	3015-P	5
E8	118384	BN	5	7.5									A	PU3	119148	20252	20320	20321	20224		
						E8	118384	BN,RD	5	7.5		4-Flat	A	PU3	119148	20252	20320	20321	20224	3025-P	5
													C	PU1,2	119191	119148	20320	20321	20224		
							74682 85219 8551511	RD RD RD	10 5			Both 7-Way 7-Way	H	PU3	119148	20252					
						E8	118384	BN,RD	5	7.5		4-Flat	A	PU3	119148	20252	20320	20321	20224	3015-P	5
						E8	118384	BN,RD	5	7.5		4-Flat	A	PU3	119148	20252	20320	20321	20224	3015-P	5
E8	118384	BN	5	7.5									A	PU3	119148	20252	20320	20321	20224		
E8	118384	BN,RD	5	7.5			85219 8551511 74682	RD RD RD	5 5 10			7-Way 7-Way Both	A	PU3	119148	20252					
													C	PU1,2	20250	119148	20320	20321	20224		
E8	118384	BN	5	7.5									A	PU3	119148	20252	20320	20321	20224		

A 2 wire system.

BN Exterior mounted plug on some or all models. May require an aftermarket electrical mounting box or bracket. (Sold separately)

C 2 or 3 wire system determine at installation.

H 3 wire system with OEM standard 2 wire harness.

RD For vehicles equipped with factory tow package may require additional components or may be used as a replacement harness.

RT4 Round Tube Class IV 2"

SQ4 Square Tube Class IV

SQ5 Square Tube Class V

MODEL / STYLE	YEAR	TRAILER HITCHES									
		PC	REC TYPE	REC SIZE	PART NO.	NO DRILL	FOOTNOTES	OPTIONAL DRAWBAR	WC (LBS.)	WD (LBS.)	IN
GMC (Continued)											
Sierra 3500 HD	15-17	42	SQ4	2	75906	0	HM,JL		1,200/8,000	1,200/12,000	30
		53	SQ5	2	41950	0	@,CS,FS,GP,JL,KH,LT		1,700/15,000	1,700/17,000	60
		57	SQ5	2-1/2	45511		#,HM		2,700/20,000	2,700/20,000	60
Sonoma w/Sportside Bed & Non-Towing Bumper	96-97	30	SQ3	2	75085	0	GP		350/3,500	750/6,000	40
Sonoma	98-04	34	SQ2	1-1/4	36248	0	GU,RH,GP	36071	300/3,500		35
		30	SQ3	2	75085	0	GP		350/3,500	750/6,000	40
		50	SQ3	2	37136		AF,CN,GU,ST		500/5,000	600/6,000	40
Suburban C1500	92-99	50	SQ3	2	37136				500/5,000	600/6,000	30
		35	SQ3	2	75037		HM		500/5,000	750/7,500	30
		41	SQ4	2	41511		HM		600/6,000	1,000/10,000	30
Suburban C2500	92-99	50	SQ3	2	37136				500/5,000	600/6,000	30
		35	SQ3	2	75037		HM		500/5,000	750/7,500	30
		41	SQ4	2	41511		HM		600/6,000	1,000/10,000	30
Suburban K1500	92-99	50	SQ3	2	37136				500/5,000	600/6,000	30
		35	SQ3	2	75037		HM		500/5,000	750/7,500	30
		41	SQ4	2	41511		HM		600/6,000	1,000/10,000	30
Suburban K2500	92-99	50	SQ3	2	37136				500/5,000	600/6,000	30
		35	SQ3	2	75037		HM		500/5,000	750/7,500	30
		41	SQ4	2	41511		HM		600/6,000	1,000/10,000	30
Terrain	10-17	18	SQ2	1-1/4	36408	0	HM	36051	300/3,500		25
		14	RT3	2	76028	0	HM		675/4,500	675/4,500	30
Terrain Diesel	18-19	28	SQ3	2	76217	0	AI,DU,JR,TZ,X		675/4,500	675/4,500	70
Terrain Except Diesel	18-19	22	SQ2	1-1/4	36642	0	JR,GP	36051	350/3,500		35
		23	SQ3	2	76419	0	JR		675/4,500	675/4,500	35
Yukon	92-00	50	SQ3	2	37136				500/5,000	600/6,000	30
		35	SQ3	2	75037		HM		500/5,000	750/7,500	30
		41	SQ4	2	41511		HM		600/6,000	1,000/10,000	30
Yukon w/Amber Turn Signals	00-02	50	SQ3	2	37136				500/5,000	600/6,000	30
Yukon w/Factory 7-Way	00-11	29	RT4	2	75725	0	CN,HM		900/6,000	1,000/10,000	15
Yukon w/Amber Turn Signals	03-06	50	SQ3	2	37136				500/5,000	600/6,000	30
		29	RT4	2	75725	0	CN,HM		900/6,000	1,000/10,000	15
Yukon	07-11										
Yukon	15-16										
Yukon Denali	99-00	50	SQ3	2	37136				500/5,000	600/6,000	30
		35	SQ3	2	75037		HM		500/5,000	750/7,500	30
		41	SQ4	2	41511		HM		600/6,000	1,000/10,000	30
Yukon Denali w/Amber Turn Signals	01-02	50	SQ3	2	37136				500/5,000	600/6,000	30
Yukon Denali w/Factory 7-Way	01-11	29	RT4	2	75725	0	CN,HM		900/6,000	1,000/10,000	15
Yukon Denali	03-06										
Yukon XL w/Factory 7-Way	00-11										
Yukon XL	07-11										
Yukon XL 1500	00-02	50	SQ3	2	37136				500/5,000	600/6,000	30
		29	RT4	2	75725	0	CN,HM		900/6,000	1,000/10,000	15
		30	SQ5	2	41930		@,CN,HM		1,000/10,000	1,200/12,000	35

#	Titan hitches require use of a 2-1/2" shank Titan ball mount.	HM	Hitch crosstube is visible beneath bumper.
@	Ultra Frame ball mount must be used to achieve maximum weight carrying rating.	JL	Installation requires OEM bumper and brackets.
AF	Hitch is ONLY rated for Weight Carrying at 3500 lbs. GTW / 350 lbs. TW and DO NOT use Weight Distribution Spring Bars for this Specific Vehicle. Except for long bed pickups.	JR	Exhaust must be temporarily lowered for installation.
AI	Additional installation time may be required.	KH	Minor heat shield modification may be required.
CN	Requires OEM factory bumper for hitch installation.	LT	Requires removal of factory hitch if equipped.
CS	Will fit with full-size spare tire stowed under vehicle.	RH	Optional drawbar #36051 required (Sold separately) except for models with ZR2 & Highrider package.
DU	Fascia removal required.	ST	Will not fit 2WD models with short bed.
FS	Includes 2 & 4 WD models with heavy duty suspension.	TZ	Requires replacement of the impact structure with hitch.
GP	Hitch crosstube concealed behind bumper.	X	Minor fascia trimming required.
GU	Will not fit vehicles with factory or aftermarket lower Fascia/Rollpan or Tube Bumper.		

T-ONE						TOW HARNESS						4-FLAT WIRING				REQ. 4 FLAT WIRING		7-WAY HARDWIRE	BRAKE CONTROL HARNESS	IN		
PC	T-ONE	FN	IN	AMP	CP	PC	TOW HARN	FN	IN	AMP	CP	TYPE	ELEC	POS	CHOICE 1	CHOICE 2	6-WAY ADAPTER				7-WAY ADAPTER	
GMC (Continued)																						
E8	118384	BN	5	7.5									A	PU3	119148	20252	20320	20321	20224	3016-P	5	
E3	118312	BN	5	7.5									A	PU3	119148	20252	20320	20321	20224			
E4	118359	BN	5	7.5									A	PU3	119148	20252	20320	20321	20224			
E3	118319	BN	5	7.5									A	SUV6	119148	20252	20320	20321	20224			
E3	118319	BN	5	7.5									A	SUV6	119148	20252	20320	20321	20224			
E3	118319	BN	5	7.5									A	SUV6	119148	20252	20320	20321	20224			
E3	118319	BN	5	7.5									A	SUV6	119148	20252	20320	20321	20224			
E16	118494	CH	45	2.1,5.6	X	E1	118264	RD	15	7.5		4-Flat	N	SUV1,2		119251	20320	20321				
E17	118764	BN,CH	45	5.7,5	X	E6	118285	BN,CH	15	7.5		4-Flat	BTT	SUV1,2								
E17	118764	BN,CH	45	5.7,5	X	E6	118285	BN,CH	15	7.5		4-Flat	BTT	SUV1,2								
E3	118319	BN	5	7.5									A	SUV6	119148	20252	20320	20321	20224			
E8	118384	BN	5	7.5									A	SUV6	119148	20252	20320	20321	20224	3025-P	5	
							74682 8551511 85219	RD RD RD	10 5			Both 7-Way 7-Way	H	SUV6	119148	20252						
E8	118384	BN	5	7.5									A	SUV6	119148	20252	20320	20321	20224	3015-P	5	
						E8	118384	BN,RD	5	7.5		4-Flat	H	SUV6	119148	20252						
E8	118384	BN	5	7.5																		
E3	118319	BN	5	7.5									A	SUV6	119148	20252	20320	20321	20224			
E8	118384	BN	5	7.5									A	SUV6	119148	20252	20320	20321	20224	3025-P	5	
							74682 8551511 85219	RD RD RD	10 5			Both 7-Way 7-Way	H	SUV6	119148	20252						
						E8	118384	BN,RD	5	7.5		4-Flat	H	SUV6	119148	20252					3015-P	5
							74682 8551511 85219	RD RD RD	10 5			Both 7-Way 7-Way	H	SUV6	119148	20252						
						E8	118384	BN,RD	5	7.5		4-Flat	H	SUV6	119148	20252						
E8	118384	BN	5	7.5									A	SUV6	119148	20252	20320	20321	20224	3025-P	5	

A 2 wire system.

BN Exterior mounted plug on some or all models. May require an aftermarket electrical mounting box or bracket. (Sold separately)

BTT Shared Brake/Tail/Turn multiplexed wiring system. ModuLite® HD Plus or Ultra required.

CH T-One is equipped with circuit protected ModuLite® module.

H 3 wire system with OEM standard 2 wire harness.

N DO NOT cut or splice vehicle wiring. Only use approved T-One or see auto dealer for trailer tow wiring kit.

RD For vehicles equipped with factory tow package may require additional components or may be used as a replacement harness.

RT3 Round Tube Class III 2"

RT4 Round Tube Class IV 2"

SQ2 Square Tube Class II

SQ3 Square Tube Class III

SQ4 Square Tube Class IV

SQ5 Square Tube Class V

MODEL / STYLE	YEAR	TRAILER HITCHES									
		PC	REC TYPE	REC SIZE	PART NO.	NO DRILL	FOOTNOTES	OPTIONAL DRAWBAR	WC (LBS.)	WD (LBS.)	IN
GMC (Continued)											
Yukon XL 1500	03-06	50	SQ3	2	37136	0	CN, HM @, CN, HM		500/5,000	600/6,000	30
		29	RT4	2	75725				900/6,000	1,000/10,000	15
		30	SQ5	2	41930				1,000/10,000	1,200/12,000	35
Yukon XL 1500 Denali	01-02	50	SQ3	2	37136	0	CN, HM @, CN, HM		500/5,000	600/6,000	30
		29	RT4	2	75725				900/6,000	1,000/10,000	15
		30	SQ5	2	41930				1,000/10,000	1,200/12,000	35
Yukon XL 1500 Denali w/Factory 7-Way	01-11										
Yukon XL 1500 Denali	07-11										
Yukon XL 2500	00-02	50	SQ3	2	37136	0	CN, HM @, CN, HM #		500/5,000	600/6,000	30
		29	RT4	2	75725				900/6,000	1,000/10,000	15
		30	SQ5	2	41930				1,000/10,000	1,200/12,000	35
		53	SQ5	2-1/2	45515				1,200/12,000	1,700/14,000	50
Yukon XL 2500	03-06	50	SQ3	2	37136	0	CN, HM @, CN, HM #		500/5,000	600/6,000	30
		29	RT4	2	75725				900/6,000	1,000/10,000	15
		30	SQ5	2	41930				1,000/10,000	1,200/12,000	35
		53	SQ5	2-1/2	45515				1,200/12,000	1,700/14,000	50
HONDA											
Accord	94-97	45	SQ1	1-1/4	24616	0	HM	3593	200/2,000		30
Accord Sedan	98-02	18	SQ1	1-1/4	24791	0	JR, HM	3592	200/2,000		15
Accord Coupe	03-05	31	SQ1	1-1/4	24787	0	HR, JR, HM	3592	200/2,000		25
Accord Sedan	03-05	31	SQ1	1-1/4	24787	0	HR, JR, HM	3592	200/2,000		25
Accord Coupe	06-07	31	SQ1	1-1/4	24787	0	HR, JR, HM	3592	200/2,000		25
Accord Sedan	06-07	31	SQ1	1-1/4	24787	0	HR, JR, HM	3592	200/2,000		25
Accord Coupe	08-12	19	SQ1	1-1/4	24899	0	HM, JR, KH	3593	200/2,000		30
Accord Sedan	08-12	19	SQ1	1-1/4	24899	0	HM, JR, KH	3593	200/2,000		30
Accord Coupe, Except w/LED Taillights	13-15	19	SQ1	1-1/4	24899	0	HM, JR, KH	3593	200/2,000		30
Accord Coupe, w/LED Taillights	13-15	19	SQ1	1-1/4	24899	0	HM, JR, KH, SV	3593	200/2,000		45
Accord Sedan, Except w/LED Taillights	13-15	19	SQ1	1-1/4	24899	0	HM, JR, KH, SV	3593	200/2,000		45
Accord Sedan, w/LED Taillights	13-15	19	SQ1	1-1/4	24899	0	HM, JR, KH, SV	3593	200/2,000		45
Accord Coupe	16	19	SQ1	1-1/4	24899	0	HM, JR, KH	3593	200/2,000		45
Accord Sedan	16-17	19	SQ1	1-1/4	24899	0	HM, JR, KH, SV	3593	200/2,000		30
Accord	18-19	19	SQ1	1-1/4	24972	0	GP, AA, DU, TA	3593	200/2,000		60
Accord Crosstour	10-11	31	SQ1	1-1/4	24852	0	HM, JR, KH	3590	200/2,000		40
Civic	92-98	29	SQ1	1-1/4	24677	0	EP, HM	3593	200/2,000		15
Civic 3 Dr. Hatchback	96-00	11	SQ1	1-1/4	24822		X, GP	3590	200/2,000		20
Civic	99-00	29	SQ1	1-1/4	24677	0	HM	3593	200/2,000		15
Civic	01-05	31	SQ1	1-1/4	24706		HM	3593	200/2,000		15
Civic Si	02-05	20	SQ1	1-1/4	24719		TA, GP	3593	200/2,000		30
Civic 2 Dr. Coupe, Except Si	06-15	27	SQ1	1-1/4	24763	0	HM, JR	3593	200/2,000		30
Civic 4 Dr. Sedan, Except Hybrid & Si	06-15	27	SQ1	1-1/4	24763	0	HM, JR	3593	200/2,000		30
Civic Hybrid	06-11	27	SQ1	1-1/4	24763	0	HM, JR	3593	200/2,000		30
Civic Si, 2 Dr. Coupe	06-11	27	SQ1	1-1/4	24763	0	HM, JR	3593	200/2,000		30
Civic Si, 4 Dr. Sedan	06-11	27	SQ1	1-1/4	24763	0	HM, JR	3593	200/2,000		30
Civic Hybrid	12-15	27	SQ1	1-1/4	24763		HM, JR, KH, SV	3593	200/2,000		35
Civic Coupe	16	24	SQ1		24946†		EP, GP, AA, DU	3593	200/2,000		65
Civic Coupe, Except Models w/Center Exhaust	16	24	SQ1	1-1/4	24954		DU, X, GP, TA	3593	200/2,000		65
Civic Hatchback, Except Models w/Center Exhaust	16-19	24	SQ1	1-1/4	24954		DU, X, GP, TA	3593	200/2,000		65
Civic Sedan	16	24	SQ1		24946†		EP, GP, AA, DU	3593	200/2,000		65
		24	SQ1	1-1/4	24937†	0	EP, GP, AA, DU	3593	200/2,000		65
Civic Sedan, Except Models w/Center Exhaust	16-19	24	SQ1	1-1/4	24954		DU, X, GP, TA	3593	200/2,000		65
Civic Coupe, Except Models w/Center Exhaust	17-19	24	SQ1	1-1/4	24954		DU, X, GP, TA	3593	200/2,000		65

Titan hitches require use of a 2-1/2" shank Titan ball mount.
 @ Ultra Frame ball mount must be used to achieve maximum weight carrying rating.
 AA Requires temporary removal of bumper during installation.
 CN Requires OEM factory bumper for hitch installation.
 DU Fascia removal required.
 EP Fascia trimming may be required.
 GP Hitch cross-tube concealed behind bumper.

HM Hitch cross-tube is visible beneath bumper.
 HR Requires drilling of heat shields on V6 models.
 JR Exhaust must be temporarily lowered for installation.
 KH Minor heat shield modification may be required.
 SV Trimming or removal of under body appearance panel may be required.
 TA Trunk access required for hitch installation.
 X Minor fascia trimming required.

T-ONE					TOW HARNESS					4-FLAT WIRING				REQ. 4 FLAT WIRING		7-WAY HARDWIRE	BRAKE CONTROL HARNESS	IN			
PC	T-ONE	FN	IN	AMP	CP	PC	TOW HARN	FN	IN	AMP	CP	TYPE	ELEC	POS	CHOICE 1				CHOICE 2	6-WAY ADAPTER	7-WAY ADAPTER
GMC (Continued)																					
E8	118384	BN	5	7.5									A	SUV6	119148	20252	20320	20321	20224	3015-P	5
E8	118384	BN	5	7.5									A	SUV6	119148	20252	20320	20321	20224	3025-P	5
							74682 8551511 85219	RD RD RD	10 5			Both 7-Way 7-Way	H	SUV6	119148	20252					
E8	118384	BN	5	7.5		E8	118384	BN,RD	5	7.5		4-Flat	H	SUV6	119148	20252	20320	20321	20224	3025-P	5
E8	118384	BN	5	7.5									A	SUV6	119148	20252	20320	20321	20224	3015-P	5
HONDA																					
E5	118336	HG	5	2.1,5									B,E	PC3	119191	119148					
E5	118336	HG	5	2.1,5									B	PC3	119130	119178					
E11	118441	CG	10	2.1,5	X								B	PC3	119130	119178					
E11	118302	HG	10	2.1,4,2									B	PC3	119130	119178					
E8	118436	HG	10	2.1,4,2									N	PC3		119251					
E11	118302	HG	10	2.1,4,2									B,E	PC3	119191	119148					
E14	118420	CG	15	2.1,5	X								B	PC3,4	119130	119178					
E14	118420	CG	15	2.1,5	X								B,E	PC3,4	119191	119148					
E16	118596	CH	45	2.1,5,6	X								B,E	PC3,4	119191	119148					
E15	118586	CH	45	2.1,5,6	X								B,E	PC3,4	119191	119148					
E16	118596	CH	45	2.1,5,6	X								B,E	PC3,4	119191	119148					
E15	118586	CH	45	2.1,5,6	X								B,E	PC3,4	119191	119148					
E17	118695	CH	45	4.2,7,5	X								B,E	PC3,4	119191	119148					
E16	118684	CH	45	4.2,7,5	X								B,E	PC3,4	119191	119148					
E15	118776	CH	45	5.7,5	X								B,E	PC1,2	119191	119148					
E11	118500	CH	15	2.1,5,6	X								B,E	SUV3	119191	119148	20320	20321			
													B,E	PC3,4	119191	119148					
													B	PC3,4	119130	119178					
													B,E	PC3,4	119191	119148					
													B,E	PC3,4	119191	119148					
													B	PC3,4	119130	119178					
E12	118437	CG	10	2.1,5	X								B	PC3,4	119130	119178					
E14	118420	CG	15	2.1,5	X								B	PC3,4	119130	119178					
													B	PC3,4	119130	119178					
													B	PC3,4	119130	119178					
													B	PC3,4	119130	119178					
													B,E	PC3,4	119191	119148					
E19	118724	CH	45	5.7,5	X								B,E	PC3,4	119191	119148					
E19	118724	CH	45	5.7,5	X								B,E	PC3,4	119191	119148					
													B,E	PC1,2	119191	119148					
E19	118686	CH	45	5.7,5	X								B,E	PC3,4	119191	119148					
E19	118686	CH	45	5.7,5	X								B,E	PC1,2	119191	119148					
													B,E	PC3,4	119191	119148					

A 2 wire system.
B 3 wire system. Converter required.
BN Exterior mounted plug on some or all models. May require an aftermarket electrical mounting box or bracket. (Sold separately)
CG T-One incorporates circuit protected taillight converter.
CH T-One is equipped with circuit protected ModuLite® module.
E ModuLite® required.
H 3 wire system with OEM standard 2 wire harness.
HG T-One incorporates taillight converter.
N DO NOT cut or splice vehicle wiring. Only use approved T-One or see auto dealer for trailer tow wiring kit.
RD For vehicles equipped with factory tow package may require additional components or may be used as a replacement harness.

RT4 Round Tube Class IV 2"
SQ1 Square Tube Class I
SQ3 Square Tube Class III
SQ5 Square Tube Class V

MODEL / STYLE	YEAR	TRAILER HITCHES									
		PC	REC TYPE	REC SIZE	PART NO.	NO DRILL	FOOTNOTES	OPTIONAL DRAWBAR	WC (LBS.)	WD (LBS.)	IN
HONDA (Continued)											
Crosstour	12	31	SQ1	1-1/4	24852	0	HM,JR,KH	3590	200/2,000		40
Crosstour	13-15	31	SQ1	1-1/4	24852	0	HM,JR,KH	3590	200/2,000		40
CR-V	97-01	18	SQ1	1-1/4	24790	0	RC,GP	3591	200/2,000		20
CR-V	02-06	27	SQ1	1-1/4	24772	0	BY,JR,HM	3593	200/2,000		20
		33	SQ3	2	75690	0	BY,HM,JR		350/3,500		30
CR-V	07-11	12	SQ1	1-1/4	24792	0	JR,HM	3592	200/2,000		20
		34	RT3	2	75547	0	HM,JR,TJ		675/4,500		25
CR-V	12-16	16	RT2	1-1/4	36520	0	HM,JR,SV	36051	300/3,500		40
		16	RT3	2	75742	0	HM,JR,SV		675/4,500		40
CR-V	17-19	16	RT2	1-1/4	36597	0	HM,JR,TW	36051	350/3,500		20
		16	RT3	2	76128	0	HM,JR,TW		675/4,500		20
CR-Z	11-12										
Element	03-04	19	SQ1	1-1/4	24720		GP	3592	200/2,000		25
		40	RT3	2	75659	0			350/3,500		30
Element Except SC	05-06	19	SQ1	1-1/4	24720		GP	3592	200/2,000		25
		40	RT3	2	75659	0			350/3,500		30
Element SC	05-06	40	RT3	2	75659	0	EP		350/3,500		35
Element Except SC	07-08	19	SQ1	1-1/4	24720		GP	3592	200/2,000		25
		40	RT3	2	75659	0			350/3,500		30
Element SC	07-10	40	RT3	2	75659	0	EP		350/3,500		35
Element Except SC	09-11	19	SQ1	1-1/4	24720		GP	3592	200/2,000		25
		40	RT3	2	75659	0			350/3,500		30
Fit	07-08	18	SQ1	1-1/4	24776	0	HM	3593	200/2,000		25
Fit	09-13	21	SQ1	1-1/4	24826	0	HM	3593	200/2,000		25
Fit	14						CH,BN				
Fit	15-19	16	RT1	1-1/4	24920	0	HM,JR	3593	200/2,000		25
HR-V	16-19	18	RT1	1-1/4	24932	0	GP,JR,SV	3593	200/2,000		35
Odyssey	95-98	35	SQ2	1-1/4	36204		HM,JR	36051	300/3,500		30
Odyssey	99-04	32	SQ2	1-1/4	36417	0	HM,JR	36071	300/3,500		20
		21	RT3	2	75270	0	HM,JR		675/4,500	675/5,000	15
Odyssey	05-10	32	SQ2	1-1/4	36417	0	HM,JR	36071	300/3,500		20
		21	RT3	2	75270	0	HM,JR		675/4,500	675/5,000	15
Odyssey	11-17	32	SQ2	1-1/4	36417	0	HM,JR	36071	300/3,500		20
		31	SQ3	2	76025	0	GP,X,DU		525/3,500		80
		21	RT3	2	75270	0	HM,JR		675/4,500	675/5,000	15
Odyssey With Fuse Provisions	18-19	26	RT2	1-1/4	36633	0	GP,DU,X,TA,TW		350/3,500		80
		32	SQ4	2	76170	0	GP,DU,X,TA,TW		525/3,500		80
		27	RT3	2	76171	0	GP,DU,X,TA,TW		675/4,500	675/5,000	80
Odyssey Without Fuse Provisions	18-19	26	RT2	1-1/4	36633	0	HM,JR,SV,TW	36071	350/3,500		25
		32	SQ4	2	76170	0	GP,DU,X,TA,TW		525/3,500		80
		27	RT3	2	76171	0	HM,JR,SV,TW		675/4,500	675/5,000	80
Passport	94-97	37	SQ3	2	75049	0	GP		500/5,000		40
Passport w/Door Mounted Spare	98-01	28	SQ2	1-1/4	362471	0	GP	36053	300/3,500		15
		32	SQ3	2	75092	0			350/3,500	500/5,000	15
Passport w/Under Vehicle Spare	98-02	30	RT3	2	75093	0			350/3,500	500/5,000	15
Passport	19										
		41	SQ3	2	76290	0	GP		900/6,000	900/8,000	20
Pilot	03-08	31	SQ3	2	75599	0	CS,GP,JR		350/3,500	500/5,000	30
Pilot	09-11										
Pilot	12-15										
Pilot	16-17	37	SQ4	2	75225	0	TA,GP		900/6,000	900/8,000	20
Pilot	18-19	37	SQ4	2	75225	0	TA,GP		900/6,000	900/8,000	20
Ridgeline	06-14	40	RT3	2	75280	0	HM,JR,TK		750/5,000	750/7,500	20

BN Exterior mounted plug on some or all models. May require an aftermarket electrical mounting box or bracket. (Sold separately)

BY Minor repositioning of muffler required.

CH T-One is equipped with circuit protected ModuLite® module.

CS Will fit with full-size spare tire stowed under vehicle.

DU Fascia removal required.

EP Fascia trimming may be required.

GP Hitch crossbar concealed behind bumper.

HM Hitch crossbar is visible beneath bumper.

JR Exhaust must be temporarily lowered for installation.

KH Minor heat shield modification may be required.

RC Will not fit with rear sport bars.

SV Trimming or removal of under body appearance panel may be required.

TA Trunk access required for hitch installation.

TJ Hitches produced before 07/13/11 are rated at 350/3500 WC.

TK Hitches produced before 09/09/11 are rated at 500/5000 WC & 600/6000 WD.

TW Receiver hitch may limit hands-free liftgate sensor range

X Minor fascia trimming required.

T-ONE						TOW HARNESS						4-FLAT WIRING				REQ. 4 FLAT WIRING		7-WAY HARDWIRE	BRAKE CONTROL HARNESS	IN
PC	T-ONE	FN	IN	AMP	CP	PC	TOW HARN	FN	IN	AMP	CP	TYPE	ELEC	POS	CHOICE 1	CHOICE 2	6-WAY ADAPTER			
HONDA (Continued)																				
E11	118500	CH	15	2.1,5,6	X								B,E	SUV3	119191	119148	20320	20321		
E11	118642	CH	15	2.1,5,6	X								B,E	SUV3	119191	119148	20320	20321		
E5	118336	HG	5	2.1,5									B	SUV3	119130	119178				
E5	118336	HG	5	2.1,5									B	SUV3	119130	119178	20320	20321	20224	
E8	118427	CG	45	2.1,5	X								B	SUV3	119130	119178	20320	20321	20224	
E17	118561	CH	45	2.1,5	X								B,E	SUV1,2	119191	119148	20320	20321	20224	
E11	118741	CH	30	5/7.5	X								B,E	SUV3	119191	119148	20320	20321	20224	
E17	118533	CH	45	2.1,5,6	X								B,E	PC3,4	119191	119148				
E5	118336	HG	5	2.1,5									B	SUV2	119130	119178	20320	20321	20224	
													B,E	SUV3,4	119191	119148	20320	20321	20224	
													B,E	SUV3,4	119191	119148	20320	20321	20224	
E14	118465	CH	45	2.1,5,6	X								B,E	SUV3,4	119191	119148	20320	20321	20224	
E14	118465	CH	45	2.1,5,6	X								B,E	SUV3,4	119191	119148	20320	20321	20224	
E14	118465	CH	45	2.1,5,6	X								B,E	SUV3,4	119191	119148	20320	20321	20224	
E14	118420	CG	15	2.1,5	X								B	PC3,4	119130	119178				
E14	118420	CG	15	2.1,5	X								B	PC3,4	119130	119178				
E23	118767		45	5.7,5	X								B,E	PC3,4	119130	119178				
E23	118767	CH,BN	45	5.7,5	X								B,E	PC3,4	119130	119178				
E14	118673	CH	45	4.2,7.5	X								B,E	SUV3,4	119191	119148				
E5	118336	HG	5	2.1,5									B	SUV3	119130	119178				
E5	118336	HG	5	2.1,5									B	SUV3	119130	119178	20320	20321	20224	
E12	118438	CH	20	2.1,4.2	X								B	SUV3,4	119130	119178	20320	20321	20224	
E17	118521	CH	30	4.2,7.5	X								B,E	SUV1,2	119191	119148	20320	20321	20224	
E11	118781	CH	45	5.7,5	X								B,E	SUV3	119191	119148	20320	20321	20224	
E13	118753	CH	45	5.7,5	X								B,E	SUV3	119191	119148	20320	20321	20224	
E7	118331	BN,HG	5	2.1,5									B	SUV1,2	119130	119178	20320	20321	20224	
E17	118360	BN,HG	15	2.1,5									B	SUV1,2	119130	119178	20320	20321	20224	
E17	118360	BN,HG	15	2.1,5									B	SUV1,2	119130	119178	20320	20321	20224	
E14	118809	CH	45	5.7,5	X	E25	118291	CH,BN	25	4.2,12	X	7-Way	B,E	SUV1,2						
E5	118336	HG	5	2.1,5									B	SUV3	119130	119178	20320	20321	20224	
E15	118491	BN,CH	20	4.2,7.5	X	E22	118253	BN,CH	20	4.2,7.5	X	7-Way	B	SUV3,6	119130	119178				3070-P 5
E25	118558	BN,CH	30	4.2,7.5	X	E30	118265	BN,CH	30	4.2,7.5	X	7-Way	B,E	SUV3,5	119191	119148				3070-P 5
E17	118760	BN,CH	45	5.7,5	X	E19	118274	BN,CH	30	4.2,7.5	X	7-Way	B	SUV3	119130	119178	20320	20321	20224	3070-P 5
E17	118760	BN,CH	45	5.7,5	X	E21	118286	BN,CH	30	4.2,12		7-Way	B	SUV3	119130	119178	20320	20321	20224	
E15	118400	BN,CG	10	2.1,5	X								B	PU1,2	119130	119178	20320	20321	20224	3070-P 5

B 3 wire system. Converter required.
BN Exterior mounted plug on some or all models. May require an aftermarket electrical mounting box or bracket. (Sold separately)
CG T-One incorporates circuit protected taillight converter.
CH T-One is equipped with circuit protected ModuLite® module.
E ModuLite® required.
HG T-One incorporates taillight converter.

RT1 Round Tube Class I 1-1/4"
RT2 Round Tube Class II 1-1/4"
RT3 Round Tube Class III 2"
SQ1 Square Tube Class I
SQ2 Square Tube Class II
SQ3 Square Tube Class III
SQ4 Square Tube Class IV

MODEL / STYLE	YEAR	TRAILER HITCHES									
		PC	REC TYPE	REC SIZE	PART NO.	NO DRILL	FOOTNOTES	OPTIONAL DRAWBAR	WC (LBS.)	WD (LBS.)	IN
HONDA (Continued)											
Ridgeline	17										
Ridgeline	18										
HUMMER											
H2 w/Factory 7-Way	03-09										
H3	06-10	43	SQ3	2	75382	0			500/5,000	500/5,000	25
H3 w/Factory 7-Way	06-10										
H3T w/Factory 7-Way	09-10										
HYUNDAI											
Accent	00-05	32	SQ1	1-1/4	247361	0	GP	3593	200/2,000		20
Accent 4 Dr. Sedan	06-11	32	SQ1	1-1/4	24760	0	GP	3590	200/2,000		20
Accent 3 Dr. Hatchback	07-11	28	SQ1	1-1/4	24795	0	JR,GP	3594	200/2,000		25
Accent 4 Dr. Sedan	12-17	30	SQ1	1-1/4	24884	0	HM	3592	200/2,000		15
Accent 5 Dr. Hatchback	12	30	SQ1	1-1/4	24884	0	HM	3592	200/2,000		15
Accent 5 Dr. Hatchback	13-17	30	SQ1	1-1/4	24884	0	HM	3592	200/2,000		15
Azera	06-11	32	SQ1	1-1/4	247711	0	JR,HM	3593	200/2,000		20
Azera	12-17	28	RT2	1-1/4	36544		HM,JR	36061	300/3,500		20
Elantra	96-00	27	SQ1	1-1/4	246461		TA,GP	3593	200/2,000		30
Elantra	01-06	33	SQ1	1-1/4	24703	0	HM	3593	200/2,000		15
Elantra 4 Dr. Sedan	07-10	28	SQ1	1-1/4	24795	0	JR,X,GP	3594	200/2,000		25
Elantra Touring, 5 Dr.	09-12	14	SQ1	1-1/4	24844	0	GP,JR	3594	200/2,000		25
Elantra 4 Dr. Sedan	11-12	17	SQ1	1-1/4	24902		HM	3594	200/2,000		25
Elantra 2 Dr. Coupe	13-14	17	SQ1	1-1/4	24902		HM,SV	3594	200/2,000		25
Elantra 4 Dr. Sedan	13-16	17	SQ1	1-1/4	24902		HM,SV	3594	200/2,000		25
Elantra 4 Dr. Except Limited & Sport Models	17	15	SQ1	1-1/4	24939		EP,JR,GP,KH	3593	200/2,000		50
Elantra 4 Dr. Limited Models Except Sport	17	15	SQ1	1-1/4	24939		EP,JR,GP,KH	3593	200/2,000		50
Elantra Except GT & Sport	18-20	23	SQ1	1-1/4	24964	0	EP,JR,GP,KH	3593	200/2,000		40
Elantra GT Except for Korean Manufactured Vehicles	13-17	25	SQ1	1-1/4	24905	0	HM	3594	200/2,000		25
Elantra GT Except Sport	18	25	SQ1	1-1/4	24970	0	DU,GP,X,SV,JR	3594	200/2,000		45
Entourage	07-09	45	RT3	2	75421	0	HM,JR		350/3,500	400/4,000	20
Genesis 4 Dr. Sedan	09-11	30	SQ2	1-1/4	36486		HM,JR,KH	36065	300/3,500		60
Genesis 2 Dr. Coupe	10-12										
Genesis 4 Dr. Sedan	12-14	30	SQ2	1-1/4	36486		HM,JR,KH	36065	300/3,500		60
Genesis Sedan	15-16										
Ioniq Hybrid	17	23	SQ1	1-1/4	24963	0	JR,GP,SV	3593	200/2,000		30
Kona	18	41	SQ1	1-1/4	24976	0	GP,JR	3593	200/2,000		35
Palisade	20										
		38	SQ3	2	76403	0	JR,X		500/4,500	750/6,000	30
Santa Fe	01-06	25	RT3	2	41543	0	GP,JR		315/3,500		35
Santa Fe	07-09	37	SQ3	2	75471	0	TG		525/3,500		20
Santa Fe	10-12	29	SQ2	1-1/4	36511	0	HM	36051	300/3,500		15
		25	SQ3	2	75684	0	HM		350/3,500	500/5,000	15
Santa Fe (6/7 Passenger)	13-18	33	RT3	2	75776	0	FP,GP,J		750/5,000	750/7,500	30
Santa Fe Sport (5 Passenger)	13-18	27	RT2	1-1/4	36536	0	HM,JJR,SV	36051	300/3,500		30
		28	RT3	2	75772	0	HM,JJR,SV		525/3,500	525/5,250	30

DU Fascia removal required.

EP Fascia trimming may be required.

FP Spare tire repositioning and/or modification of spare tire carrier may be required.

GP Hitch cross-tube concealed behind bumper.

HM Hitch cross-tube is visible beneath bumper.

J Under vehicle spare tire stowage is retained.

JR Exhaust must be temporarily lowered for installation.

KH Minor heat shield modification may be required.

SV Trimming or removal of under body appearance panel may be required.

TA Trunk access required for hitch installation.

TG Hitches produced before 05/13/11 are rated at 350/3500 WC.

X Minor fascia trimming required.

T-ONE						TOW HARNESS						4-FLAT WIRING				REQ. 4 FLAT WIRING			7-WAY HARDWARE	BRAKE CONTROL HARNESS	IN		
PC	T-ONE	FN	IN	AMP	CP	PC	TOW HARN	FN	IN	AMP	CP	TYPE	ELEC	POS	CHOICE 1	CHOICE 2	6-WAY ADAPTER	7-WAY ADAPTER					
HONDA (Continued)																							
E10	118778	BN,CH	20	4.2,7.5	X	E14	118288	BN,CH	20	4.2,7.5	X	7-Way	B,E	PU1,2							3070-P	5	
E10	118778	BN,CH	20	4.2,7.5	X	E14	118288	BN,CH	20	4.2,7.5	X	7-Way	B,E	PU1,2									
HUMMER																							
						E8	118384 74682 8551511 85219	BN,RD RD RD RD	5 10 5	7.5		4-Flat Both 7-Way 7-Way	H	SUV6	119148	20252						3015-P	5
						E8	118384	BN,RD	5	7.5		4-Flat	A	SUV6	119148	20252	20320	20321	20224				
E8	118384	BN,RD	5	7.5			74682 8551511 85219	RD RD RD	10 5			Both 7-Way 7-Way	A	SUV6	119148	20252							
E8	118384	BN,RD	5	7.5		E8	118384 74682 8551511 85219	BN,RD RD RD RD	5 10 5	7.5		4-Flat Both 7-Way 7-Way	A	SUV6	119148	20252							
HYUNDAI																							
													B	PC3,4	119130	119178							
													B	PC1,2	119130	119178							
													B	PC1,2	119130	119178							
E16	118559	CH	45	2.1,5.6	X								B,E	PC3,4	119191	119148							
													B,E	PC3,4	119191	119148							
E15	118771	CH	45	5.7,5	X								B,E	PC3,4	119191	119148							
E10	118413	HG	20	2.1,4.2									B,E	PC3,4	119191	119148							
E15	118595	CH	45	2.1,5.6	X								B,E	PC3,4	119191	119148							
													B	PC3,4	119130	119178							
													B	PC3,4	119130	119178							
E12	118433	CG	10	2.1,5	X								B	PC3,4	119130	119178							
E11	118473	CG	15	2.1,7.5	X								B	PC3,4	119130	119178							
E16	118532	CH	45	2.1,5.6	X								B,E	PC3,4	119191	119148							
E16	118532	CH	45	2.1,5.6	X								B,E	PC3,4	119191	119148							
E16	118532	CH	45	2.1,5.6	X								B,E	PC3,4	119191	119148							
E15	118692	CH	45	4.2,7.5	X								B,E	PC3,4	119191	119148							
E15	118711	CH	45	4.2,7.5	X								B,E	PC3,4	119191	119148							
E15	118692	CH	45	4.2,7.5	X								B,E	PC3,4	119191	119148							
E15	118692	CH	45	4.2,7.5	X								B,E	PC3,4	119191	119148							
													B,E	PC3,4	119191	119148							
E19	118410	BN,CH	45	2.1,5.6	X								B,E	SUV1,2	119191	119148	20320	20321	20224				
E15	118476	CH	15	2.1,5.6	X								B,E	PC3,4	119191	119148							
E16	118522	CH	45	2.1,5.6	X								B,E	PC3,4	119191	119148							
													B,E	PC3,4	119191	119148							
E13	118738	CH	45	5.7,5	X								B,E	PC3,4	119191	119148							
E14	118758	CH	45	5.7,5	X								A,E	PC3,4									
													B,E	SUV5,7	119191	119148,1 19251							
E11	118784	CH	15	5.7,5	X								B,E	SUV5	119191	119148							
E11	118473	CG	15	2.1,7.5	X								B	SUV3,4	119130	119178	20320	20321	20224				
E12	118415	CG	20	2.1,5	X	E14	118258	CH	25	2.1,5.6	X	4-Flat	B	SUV3,4	119130	119178	20320	20321	20224				
E12	118415	CG	20	2.1,5	X	E14	118258	CH	25	2.1,5.6	X	4-Flat	B,E	SUV5	119191	119148	20320	20321	20224				
E13	118269		20	4.2,7.5	X								B,E	SUV1,2	119191	119148	20320	20321	20224				
E18	118571	BN,CH	45	4.2,7.5	X	E13	118269	BN,CH	20	4.2,7.5	X	4-Flat	B,E	SUV1,2	119191	119148	20320	20321	20224				

A 2 wire system.
B 3 wire system. Converter required.
BN Exterior mounted plug on some or all models. May require an aftermarket electrical mounting box or bracket. (Sold separately)
CG T-One incorporates circuit protected taillight converter.
CH T-One is equipped with circuit protected ModuLite® module.
E ModuLite® required.
H 3 wire system with OEM standard 2 wire harness.
HG T-One incorporates taillight converter.
RD For vehicles equipped with factory tow package may require additional components or may be used as a replacement harness.

RT2 Round Tube Class II 1-1/4"
RT3 Round Tube Class III 2"
SQ1 Square Tube Class I
SQ2 Square Tube Class II
SQ3 Square Tube Class III

MODEL / STYLE	YEAR	TRAILER HITCHES									
		PC	REC TYPE	REC SIZE	PART NO.	NO DRILL	FOOTNOTES	OPTIONAL DRAWBAR	WC (LBS.)	WD (LBS.)	IN
HYUNDAI (Continued)											
Santa Fe	19	36	RT3	2	75908	0	HM,TA,JR		500/5,000		40
Santa Fe XL	19					0	HM,TA,JR				40
Sonata	02-05	31	SQ1	1-1/4	247131	0	HM	3593	200/2,000		15
Sonata	06-09	24	SQ1	1-1/4	24757	0	HM	3592	200/2,000		20
Sonata	10	24	SQ1	1-1/4	24757	0	HM	3592	200/2,000		20
Sonata Except Hybrid	11-14	22	SQ1	1-1/4	24965	0	HM,JR,KH,SV	3593	200/2,000		40
Sonata Hybrid	11-14	22	SQ1	1-1/4	24965	0	HM,JR,KH,SV	3593	200/2,000		40
Sonata Except Hybrid	15-17	22	SQ1	1-1/4	24965	0	HM,JR,KH,SV	3593	200/2,000		40
Sonata Hybrid	15-16	22	SQ1	1-1/4	24965	0	HM,JR,KH,SV	3593	200/2,000		40
Sonata Except Hybrid	18-19	22	SQ1	1-1/4	24965	0	HM,JR,KH,SV	3593	200/2,000		40
Tiburon	03-08	25	SQ1	1-1/4	247261		TA,HM	3592	200/2,000		45
Tucson	05-09	32	SQ2	1-1/4	36363	0	GP,JR	36051	300/3,500		25
		30	SQ3	2	75561	0	GP,JR		350/3,500		25
Tucson	10-15	21	SQ2	1-1/4	36510	0	GP,JR	36051	300/3,500		20
		23	SQ3	2	75717	0	GP,JR		525/3,500	525/5,250	20
Tucson	16-18	26	RT2	1-1/4	36572	0	GP,JR	36051	300/3,500		30
		28	SQ3	2	75836	0	GP,JR		525/3,500		30
Tucson	19										
Veracruz	07-12	53	SQ3	2	75532	0	HM,JR		500/5,000	500/5,000	30
INFINITI											
FX35	09-12	38	RT3	2	75778	0			400/4,000		40
FX37	13	38	RT3	2	75778		HM		400/4,000		40
FX50	09-13	38	RT3	2	75778		HM		400/4,000		40
G35 4 Dr. Sedan	07-08	11	SQ1	1-1/4	24831		EP,GP	3593	200/2,000		45
G37 4 Dr. Sedan	09-13	11	SQ1	1-1/4	24831		EP,GP	3593	200/2,000		45
I30	96-99	34	SQ1	1-1/4	24686		TA,GP	3593	200/2,000		30
I30	00-01	34	SQ1	1-1/4	24686		TA,GP	3592	200/2,000		30
I35	02-04	34	SQ1	1-1/4	24686		TA,GP	3592	200/2,000		30
JX35	13	25	SQ4	2	76031	0	HM		900/6,000	900/6,000	25
Q50	14-17	27	SQ1	1-1/4	24931		GP,JR	3592	200/2,000		40
Q50	18-19										
QX30 Except Sport Model	17	36	SQ3	2	75223	0	GP,JR,TA,KH		350/3,500		90
QX4	97-03	39	SQ2	1-1/4	362221	0	HM	36071	300/3,500		20
		34	RT3	2	75077	0			500/5,000	550/5,500	20
QX50	19	35	SQ3	2	76240	0			400/4,000		20
QX56	04-10	38	RT4	2	75741	0	HM		600/6,000	1,000/10,000	15
QX56 w/Factory 7-Way	04-12										
QX60	14-15	25	SQ4	2	76031	0	HM		900/6,000	900/6,000	25
QX60	16-17	25	SQ4	2	76031	0	HM		900/6,000	900/6,000	25
QX60	18-19	25	SQ4	2	76031	0	HM		900/6,000	900/6,000	25
QX70	14-19	38	RT3	2	75778		HM		400/4,000		40
ISUZU											
Amigo w/Door Mounted Spare	98-00	28	SQ2	1-1/4	362471	0	GP	36053	300/3,500		15
Ascender w/Factory 7-Way	03-08										
Axiom w/Under Vehicle Spare	02-03	30	RT3	2	75093				350/3,500	500/5,000	20
D-Max	13	51	SQ3	2	75792	0	GP		600/4,000	600/6,000	20
Hombre w/Step Bumper	96-97	34	SQ2	1-1/4	36248	0	GU,HM,RH	36071	300/3,500		35
		34	SQ3	2	75051	0	GP,GU		350/3,500	750/6,000	40

EP Fascia trimming may be required.
 GP Hitch cross-tube concealed behind bumper.
 GU Will not fit vehicles with factory or aftermarket lower Fascia/Rollpan or Tube Bumper.
 HM Hitch cross-tube is visible beneath bumper.
 JR Exhaust must be temporarily lowered for installation.

KH Minor heat shield modification may be required.
 RH Optional drawbar #36051 required (Sold separately) except for models with ZR2 & Highrider package.
 SV Trimming or removal of under body appearance panel may be required.
 TA Trunk access required for hitch installation.

T-ONE					TOW HARNESS					4-FLAT WIRING				REQ. 4 FLAT WIRING		7-WAY HARDWARE	BRAKE CONTROL HARNESS	IN			
PC	T-ONE	FN	IN	AMP	CP	PC	TOW HARN	FN	IN	AMP	CP	TYPE	ELEC	POS	CHOICE 1				CHOICE 2	6-WAY ADAPTER	7-WAY ADAPTER
HYUNDAI (Continued)																					
E11	118784	BN,CH	15	5.7,5	X								B,E	SUV5	119191	119148					
E13	118269	BN,CH	20	4.2,7.5	X								B	PC3,4	119130	119178					
E12	118433	CG	10	2.1,5	X								B	PC3,4	119130	119178					
E16	118557	CH	45	4.2,7.5	X								B,E	PC3,4	119191	119148					
E16	118557	CH	45	4.2,7.5	X								B,E	PC3,4	119191	119148					
E14	118663		45	4.2,7.5	X								B,E	PC3,4	119191	119148					
E15	118644	CH	45	2.1,5.6	X								B,E	PC3,4	119191	119148					
E14	118663		45	4.2,7.5	X								B,E	PC3,4	119191	119148					
E15	118762	CH	45	5.7,5	X								B,E	PC3,4	119191	119148					
E16	118397	CG	30	2.1,5	X								B	SUV1,2	119130	119178	20320	20321	20224		
E18	118501	CH	30	2.1,5.6	X								B,E	SUV1,2	119191	119148	20320	20321	20224		
E18	118501	CH	30	2.1,5.6	X								B,E	SUV1,2	119191	119148					
		CH											B,E	SUV1,2	119191	119148	20320	20321	20224		
E13	118269	BN,CH	20	4.2,7.5	X								B,E	SUV7	119191	119148	20320	20321	20224		
INFINITI																					
E16	118593	CH	45	4.2,7.5	X								B,E	SUV3,4	119191	119148	20320	20321	20224		
E16	118593	CH	45	4.2,7.5	X								B,E	SUV3,4	119191	119148	20320	20321	20224		
E16	118593	CH	45	4.2,7.5	X								B,E	SUV3,4	119191	119148	20320	20321	20224		
E15	118480	CH	45	2.1,5.6	X								B,E	PC3,4	119191	119148					
E15	118480	CH	45	2.1,5.6	X								B,E	PC3,4	119191	119148					
													E	PC3,4	119191	119148					
													B	PC3,4	119130	119178					
													B	PC3,4	119130	119178					
													B,E	SUV1,2	119191	119148					
E15	118672	CH	45	4.2,7.5	X								B,E	PC3,4	119191	119148					
E15	118672	CH	45	4.2,7.5	X								B,E	PC3,4	119191	119148					
E15	118736	CH	45	4.2,7.5	X								A,E	SUV3,4	119191	119148					
E10	118361	HG	20	2.1,5									B	SUV1,2	119130	119178	20320	20321	20224		
E18	118796	BN,CH	45	5.7,5	X								B,E	SUV1,2	119191	119148					
						E8	118384	BN,RD	5	7.5		4-Flat	A	SUV6	119148	20252	20320	20321	20224	3050-P	5
							74682	RD	10			Both	H	SUV6	119148	20252					
							85219	RD	5			7-Way									
E20	118670	BN	30	7.5		E23	118273	BN,RD	20	10		7-Way	B,E	SUV1,2	119191	119148	20320	20321	20224		
E20	118670	BN	30	7.5									B,E	SUV1,2	119191	119148	20320	20321	20224	3050-P	5
E20	118670	BN	30	7.5									B,E	SUV1,2	119191	119148	20320	20321	20224		
													B,E	SUV3,4	119191	119148	20320	20321	20224		
ISUZU																					
E17	118360	BN,HG	15	2.1,5									B	SUV1,2	119130	119178					
						E8	118384	BN,RD	5	7.5		4-Flat	H	SUV6	119148	20252					
							74682	RD	10			Both									
							8551511	RD	5			7-Way									
							85219	RD	5			7-Way									
													B	SUV1,2	119130	119178	20320	20321	20224		
													B,E	PU1,2	119191	119148	20320	20321			
E3	118312	BN	5	7.5									A	PU3	119148	20252	20320	20321	20224		

- A** 2 wire system.
- B** 3 wire system. Converter required.
- BN** Exterior mounted plug on some or all models. May require an aftermarket electrical mounting box or bracket. (Sold separately)
- CG** T-One incorporates circuit protected taillight converter.
- CH** T-One is equipped with circuit protected ModuLite® module.
- E** ModuLite® required.
- H** 3 wire system with OEM standard 2 wire harness.
- HG** T-One incorporates taillight converter.
- RD** For vehicles equipped with factory tow package may require additional components or may be used as a replacement harness.

- RT2** Round Tube Class II 1-1/4"
- RT3** Round Tube Class III 2"
- RT4** Round Tube Class IV 2"
- SQ1** Square Tube Class I
- SQ2** Square Tube Class II
- SQ3** Square Tube Class III
- SQ4** Square Tube Class IV

RECEIVER HITCH APPLICATION GUIDE

ISUZU

MODEL / STYLE	YEAR	TRAILER HITCHES									
		PC	REC TYPE	REC SIZE	PART NO.	NO DRILL	FOOTNOTES	OPTIONAL DRAWBAR	WC (LBS.)	WD (LBS.)	IN
ISUZU (Continued)											
Hombre w/Step Bumper	98-00	34	SQ2	1-1/4	36248	0	GU,RH,GP	36071	300/3,500		35
		30	SQ3	2	75085	0	GP		350/3,500	750/6,000	40
		50	SQ3	2	37136		AF,CN,GU,ST		500/5,000	600/6,000	40
i-280	06	23	SQ4	2	75607	0	GP		600/6,000	750/7,500	25
i-290	07-08	23	SQ4	2	75607	0	GP		600/6,000	750/7,500	25
i-350	06	23	SQ4	2	75607	0	GP		600/6,000	750/7,500	25
i-370	07-08	23	SQ4	2	75607	0	GP		600/6,000	750/7,500	25
MU-X	13-15	35	SQ4	2	75220†	0	DJ,EP		600/6,000	600/6,000	45
Oasis	96-99	35	SQ2	1-1/4	36204		HM,JR	36051	300/3,500		30
Rodeo	92-97	37	SQ3	2	75049	0	GP		500/5,000		40
Rodeo w/Door Mounted Spare	98-01	28	SQ2	1-1/4	36247†	0	GP	36053	300/3,500		15
		32	SQ3	2	75092	0			350/3,500	500/5,000	15
Rodeo w/Under Vehicle Spare, Except w/3.5L	98-04	30	RT3	2	75093	0			350/3,500	500/5,000	15
Rodeo Sport 2 Dr., w/Door Mounted Spare	01-03	28	SQ2	1-1/4	36247†	0	GP	36053	300/3,500		15
Trooper	92-02	41	SQ3	2	75043†		HM		500/5,000	750/7,500	40
JAGUAR											
E-Pace	18-19										
		33	SQ3	2	76330	0	GP,DU,EP		350/3,500		90
F-Pace	17-19	37	SQ4	2	76026	0	GP,AA,DU,SV,TA,TZ		900/6,000		90
JEEP											
Cherokee	97-01	34	SQ2	1-1/4	36260	0	GP	36071	300/3,500		30
		30	SQ3	2	75054		GP		350/3,500	550/5,500	40
		50	SQ3	2	37136				500/5,000	600/6,000	45
Cherokee	14-18	30	SQ3	2	75998	0	EP,GP		500/5,000	500/5,000	60
Cherokee Trailhawk	14-15	35	RT3	2	75838	0	HM		600/5,000	600/6,000	30
Cherokee	19	30	SQ3	2	75998	0	EP,GP		500/5,000	500/5,000	60
Commander	06-10	16	SQ2	1-1/4	36362	0	GP	36051	300/3,500		20
		19	SQ3	2	75338	0	TL		750/5,000	750/7,500	20
Commander w/Factory 7-Way	06-10										
Compass	07-10	22	SQ2	1-1/4	36423	0	GP	36061	300/3,500		15
		23	SQ3	2	75712	0	GP,TU		525/3,500		15
Compass Rallye Edition	07-10	22	SQ2	1-1/4	36423	0	EP,GP	36061	300/3,500		30
		23	SQ3	2	75712	0	EP,GP,TU		525/3,500		30
Compass (Old Body Style)	11-17	22	SQ2	1-1/4	36423	0	EP,GP	36061	300/3,500		30
		23	SQ3	2	75712	0	EP,GP,TU		525/3,500		30
Compass (New Body Style)	17-19	25	RT2	1-1/4	36598	0	HM,JR,KH	36061	350/3,500		40
		26	RT3	2	76144	0	HM,JR,KH		675/4,500		40
Gladiator	20					0					20
Grand Cherokee	94-98	50	SQ3	2	37136				500/5,000	600/6,000	35
		30	SQ3	2	75041	0	GP		500/5,000	750/7,500	40
Grand Cherokee	99	33	SQ2	1-1/4	36276	0	HM	36051	300/3,500		15
		31	SQ3	2	75139	0			500/5,000	750/7,500	15
Grand Cherokee	00-04	33	SQ2	1-1/4	36276	0	HM	36051	300/3,500		15
		31	SQ3	2	75139	0			500/5,000	750/7,500	15
Grand Cherokee w/Factory 7-Way	00-04										
Grand Cherokee Except SRT-8	05-06	16	SQ2	1-1/4	36362	0	AI,GP	36051	300/3,500		90
		19	SQ3	2	75338	0	AI,TL		750/5,000	750/7,500	90
Grand Cherokee Except SRT-8 & w/OEM Tow Hook, w/Factory 7-Way	05-10										
Grand Cherokee w/OEM Tow Hook, w/Factory 7-Way	05-10										
Grand Cherokee Except SRT-8	07-10	16	SQ2	1-1/4	36362	0	AI,GP	36051	300/3,500		90
		19	SQ3	2	75338	0	AI,TL		750/5,000	750/7,500	90
Grand Cherokee Except w/OEM Tow Hook	11-13	21	SQ3	2	75699	0	GP		500/5,000	750/7,500	20

- AA** Requires temporary removal of bumper during installation.
- AF** Hitch is ONLY rated for Weight Carrying at 3500 lbs. GTW / 350 lbs. TW and DO NOT use Weight Distribution Spring Bars for this Specific Vehicle. Except for long bed pickups.
- AI** Additional installation time may be required.
- CN** Requires OEM factory bumper for hitch installation.
- DU** Fascia removal required.
- EP** Fascia trimming may be required.
- GP** Hitch cross-tube concealed behind bumper.
- GU** Will not fit vehicles with factory or aftermarket lower Fascia/Rollpan or Tube Bumper.
- HM** Hitch cross-tube is visible beneath bumper.

- JR** Exhaust must be temporarily lowered for installation.
- KH** Minor heat shield modification may be required.
- RH** Optional drawbar #36051 required (Sold separately) except for models with ZR2 & Highrider package.
- ST** Will not fit 2WD models with short bed.
- SV** Trimming or removal of under body appearance panel may be required.
- TA** Trunk access required for hitch installation.
- TL** Hitches produced before 10/31/11 are rated at 500/5000 WC & 750/7500 WD.
- TU** Hitches produced before 07/24/12 are rated at 350/3500 WC.
- TZ** Requires replacement of the impact structure with hitch.

RECEIVER HITCHES

T-ONE						TOW HARNESS						4-FLAT WIRING				REQ. 4 FLAT WIRING		7-WAY HARDWARE	BRAKE CONTROL HARNESS	IN
PC	T-ONE	FN	IN	AMP	CP	PC	TOW HARN	FN	IN	AMP	CP	TYPE	ELEC	POS	CHOICE 1	CHOICE 2	6-WAY ADAPTER			
ISUZU (Continued)																				
E4	118359	BN	5	7.5									A	PU3	119148	20252	20320	20321	20224	
E10	118301	BN,CG	10	2.1,5	X								B	PU3	119130	119178	20320	20321	20224	
E10	118301	BN,CG	10	2.1,5	X								B	PU3	119130	119178	20320	20321	20224	
E10	118301	BN,CG	10	2.1,5	X								B	PU3	119130	119178	20320	20321	20224	
													B,E	SUV1.2	119191	119148				
E5	118336	HG	5	2.1,5									B	SUV3	119130	119178				
E7	118331	BN,HG	5	2.1,5									B	SUV1.2	119130	119178	20320	20321	20224	
E17	118360	BN,HG	15	2.1,5									B	SUV1.2	119130	119178	20320	20321	20224	
E17	118360	BN,HG	15	2.1,5									B	SUV1.2	119130	119178				
E5	118339	BN,HG	5	2.1,5									B	SUV5	119130	119178	20320	20321	20224	
JAGUAR																				
E17	118788	BN,CH	45	5.7,5	X								A,E	SUV1.2	119191	119148				
E16	118785	CH,BN	45	5.7,5	X								A,E	SUV1.2	119191	119148				
JEEP																				
E8	118354	HG	20	2.1,5									B	SUV3	119130	119178	20320	20321	20224	
E18	118605	CH,BN	45	4.2,7,5	X								A,E	SUV1.2	119191	119148	20320	20321	20224	3014-P 5
E18	118605	CH,BN	45	4.2,7,5	X								A,E	SUV1.2	119191	119148	20320	20321	20224	3014-P 5
E17	118779	CH,BN	45	5.7,5	X								N	SUV1.2						3014-P 5
E16	118408	BN,CG	15	2.1,5	X	E3	118381	BN,RD	5	7.5		4-Flat	B	SUV1.2	119130	119178	20320	20321	20224	
							20135	RD	10			Both	H	SUV6	119148	20252				
E18	118428	BN,CH	45	2.1,4.2	X								B,E	SUV1.2	119191	119148	20320	20321	20224	
E18	118428	BN,CH	45	2.1,4.2	X								B,E	SUV1.2	119191	119148	20320	20321	20224	
E20	118539	BN,CH	45	4.2,7,5	X								B,E	SUV1.2	119191	119148	20320	20321	20224	
E20	118752	BN,CH	45	5.7,5	X								A,E	SUV1.2						
E21	118786	BN,CH	45	5.7,5	X								A,E	PU1.2						3073-P 10
E16	118349	CH,JM	45	2.1,4.2									B,E	SUV3,4	119191	119148	20320	20321	20224	
E10	118369	CH	10	2.1,4.2									B,E	SUV3,4	119191	119148	20320	20321	20224	
E10	118369	CH	10	2.1,4.2		E3	118381	BN,RD	5	7.5		4-Flat	B,E	SUV3,4	119191	119148	20320	20321	20224	
							20135	RD	10			Both	H	SUV6	119148	20252				
E17	118394	BN,CG	20	2.1,5	X	E3	118381	BN,RD	5	7.5		4-Flat	B	SUV1.2	119130	119178	20320	20321	20224	
							20135	RD	10			Both	H	SUV6	119148	20252				
							20135	RD	10			Both	H	SUV6	119148	20252				
E7	118425	BN	20	7.5		E3	118381	BN,RD	5	7.5		4-Flat	A	SUV1.2	119148	20252	20320	20321	20224	
E7	118425	BN	20	7.5		E8	118384	BN,RD	5	7.5		4-Flat	A	SUV1.2	119148	20252	20320	20321	20224	3045-P 5

- A** 2 wire system.
- B** 3 wire system. Converter required.
- BN** Exterior mounted plug on some or all models. May require an aftermarket electrical mounting box or bracket. (Sold separately)
- CG** T-One incorporates circuit protected taillight converter.
- CH** T-One is equipped with circuit protected ModuLite® module.
- E** ModuLite® required.
- H** 3 wire system with OEM standard 2 wire harness.
- HG** T-One incorporates taillight converter.
- JM** Some early production 1994 models may require #118348.
- N** DO NOT cut or splice vehicle wiring. Only use approved T-One or see auto dealer for trailer tow wiring kit.
- RD** For vehicles equipped with factory tow package may require additional components or may be used as a replacement harness.

- RT2** Round Tube Class II 1-1/4"
- RT3** Round Tube Class III 2"
- SQ2** Square Tube Class II
- SQ3** Square Tube Class III
- SQ4** Square Tube Class IV

RECEIVER HITCH APPLICATION GUIDE

MODEL / STYLE	YEAR	TRAILER HITCHES									
		PC	REC TYPE	REC SIZE	PART NO.	NO DRILL	FOOTNOTES	OPTIONAL DRAWBAR	WC (LBS.)	WD (LBS.)	IN
JEEP (Continued)											
Grand Cherokee w/Factory 7-Way	11-12										
Grand Cherokee w/OEM Tow Hook	11-13	21	SQ3	2	75699	0	AI,GP		500/5,000	750/7,500	40
Grand Cherokee EcoDiesel	14-19	25	RT4	2	75713	0	CS,HM		900/6,000	900/7,500	20
Grand Cherokee Except w/OEM Tow Hook or ECODiesel Engine	14-19	21	SQ3	2	75699	0	GP		500/5,000	750/7,500	20
Grand Cherokee w/OEM Tow Hook, Except w/ECODiesel Engine	14-19	21	SQ3	2	75699	0	AI,GP		500/5,000	750/7,500	40
Liberty	02-04	33	SQ2	1-1/4	363031	0	GP	36071	300/3,500		15
		50	SQ3	2	37136				500/5,000	600/6,000	35
		23	SQ3	2	75128	0	GP,TM		750/5,000	750/7,500	15
Liberty	05-07	33	SQ2	1-1/4	363031	0	GP	36071	300/3,500		15
		50	SQ3	2	37136				500/5,000	600/6,000	35
		23	SQ3	2	75128	0	GP,TM		750/5,000	750/7,500	15
Liberty w/Factory 7-Way	05-08										
Liberty	08	31	SQ2	1-1/4	36451	0	HM	36071	300/3,500		15
		36	RT3	2	75578	0	HM		500/5,000	750/7,500	20
Liberty	09-12	31	SQ2	1-1/4	36451	0	HM	36071	300/3,500		15
		36	RT3	2	75578	0	HM		500/5,000	750/7,500	20
Liberty w/Factory 7-Way	09-12										
Patriot	07	22	SQ2	1-1/4	36423	0	GP	36061	300/3,500		15
		23	SQ3	2	75712	0	GP,TU		525/3,500		15
Patriot	08-17	22	SQ2	1-1/4	36423	0	EP,GP	36061	300/3,500		30
		23	SQ3	2	75712	0	EP,GP,TU		525/3,500		30
Renegade	15-18	27	RT2	1-1/4	36587		HM	36071	300/3,500		30
		26	RT3	2	76021		HM,JR		675/4,500		40
TJ (Canada Only)	97	27	SQ1	1-1/4	24631	0	DA,HM	3590	200/2,000		15
		29	SQ2	1-1/4	36238	0	HM	36071	300/3,500		15
		31	SQ3	2	41531	0	HM		300/3,500		15
		28	RT3	2	75193	0	HM,TD		400/4,000		15
TJ (Canada Only)	98-06	27	SQ1	1-1/4	24631	0	DA,HM	3590	200/2,000		15
		29	SQ2	1-1/4	36238	0	HM	36071	300/3,500		15
		31	SQ3	2	41531	0	HM		300/3,500		15
		28	RT3	2	75193	0	HM,TD		400/4,000		15
Wrangler	97	27	SQ1	1-1/4	24631	0	DA,HM	3590	200/2,000		15
		29	SQ2	1-1/4	36238	0	HM	36071	300/3,500		15
		31	SQ3	2	41531	0	HM		300/3,500		15
		28	RT3	2	75193	0	HM,TD		400/4,000		15
Wrangler	98-06	27	SQ1	1-1/4	24631	0	DA,HM	3590	200/2,000		15
		29	SQ2	1-1/4	36238	0	HM	36071	300/3,500		15
		31	SQ3	2	41531	0	HM		300/3,500		15
		28	RT3	2	75193	0	HM,TD		400/4,000		15
Wrangler Except w/Right Hand Drive	07-17	11	SQ3	2	76104	0			675/4,500	675/4,500	20
Wrangler Except w/Right Hand Drive, Hard Rock Edition, 75th Anniversary Edition & vehicles with Mopar Off Road Bumper #82213654	07-17	22	SQ2	1-1/4	364241	0	GP	36071	300/3,500		20
		10	SQ3	2	755151	0			675/4,500	675/4,500	20
Wrangler Right Hand Drive	07-17	11	SQ3	2	76104	0			675/4,500	675/4,500	20
Wrangler Right Hand Drive, Except Hard Rock Edition, 75th Anniversary Edition & vehicles with Mopar Off Road Bumper #82213654	07-17	22	SQ2	1-1/4	364241	0	GP	36071	300/3,500		20
		10	SQ3	2	755151	0			675/4,500	675/4,500	20
Wrangler JL (New Body Style)	18-19	22	SQ2	1-1/4	364241	0	GP	36071	300/3,500		20
		10	SQ3	2	755151	0			675/4,500	675/4,500	20
		11	SQ3	2	76104	0			675/4,500	675/4,500	20
Wrangler JK Except w/Right Hand Drive	18	11	SQ3	2	76104	0			675/4,500	675/4,500	20

- AI** Additional installation time may be required.
- CS** Will fit with full-size spare tire stowed under vehicle.
- DA** Will not fit with tube style bumper.
- EP** Fascia trimming may be required.
- GP** Hitch cross-tube concealed behind bumper.
- HM** Hitch cross-tube is visible beneath bumper.
- JR** Exhaust must be temporarily lowered for installation.
- TD** Hitches without electrical bracket are rated at 350/3500 WC & No WD. Hitch with electrical bracket rated at 400/4000 WC & No WD.
- TM** Hitches produced before 01/04/12 are rated at 500/5000 WC & 750/7500 WD.
- TU** Hitches produced before 07/24/12 are rated at 350/3500 WC.

T-ONE						TOW HARNESS						4-FLAT WIRING				REQ. 4 FLAT WIRING		7-WAY HARDWARE	BRAKE CONTROL HARNESS	IN	
PC	T-ONE	FN	IN	AMP	CP	PC	TOW HARN	FN	IN	AMP	CP	TYPE	ELEC	POS	CHOICE 1	CHOICE 2	6-WAY ADAPTER				7-WAY ADAPTER
JEEP (Continued)																					
							74682 85219	RD RD	10 5			Both 7-Way	H	SUV6	119148	20252					
E7	118425	BN	20	7.5		E8	118384	BN,RD	5	7.5		4-Flat	A	SUV1,2	119148	20252	20320	20321	20224	3045-P	5
E18	118727	BN,CH	45	5.7,5	X								A,E	SUV1,2	119191	119148	20320	20321	20224	3045-P	5
E18	118727	BN,CH	45	5.7,5	X								A,E	SUV3,4	119191	119148	20320	20321	20224	3045-P	5
E18	118727	BN,CH	45	5.7,5	X								A,E	SUV3,4	119191	119148	20320	20321	20224	3045-P	5
E20	118524	HG	45	4.2,7.5	X								B	SUV1,2	119130	119178	20320	20321	20224		
E20	118524	HG	45	4.2,7.5	X	E3	118381	BN,RD	5	7.5		4-Flat	B	SUV1,2	119130	119178	20320	20321	20224		
							20135	RD	10			Both	H	SUV6	119148	20252					
E19	118554	BN,CH	45	4.2,7.5	X	E3	118381	BN,RD	5	7.5		4-Flat	B,E	SUV1,2	119191	119148	20320	20321	20224		
E19	118554	BN,CH	45	4.2,7.5	X	E8	118384	BN,RD	5	7.5		4-Flat	B,E	SUV1,2	119191	119148	20320	20321	20224		
							74682 85219	RD RD	10 5			Both 7-Way	H	SUV6	119148	20252					
E18	118428	BN,CH	45	2.1,4.2	X								B,E	SUV1,2	119191	119148	20320	20321	20224		
E18	118552	CH	45	4.2,7.5	X								A,E	SUV1,2	119191	119148	20320	20321	20224		
E26	118651	CH	45	4.2,7.5	X								BTT	SUV3,4	119251	119191	20320	20321			
E5	118356	BN	10	7.5									A	SUV5,7	119148	20252	20320	20321	20224		
E7	118409	BN	15	7.5									A	SUV5,7	119148	20252	20320	20321	20224		
E5	118356	BN	10	7.5									A	SUV5,7	119148	20252	20320	20321	20224		
E7	118409	BN	15	7.5									A	SUV5,7	119148	20252	20320	20321	20224		
E5	118416	BN	10	7.5									A	SUV1	119148	20252	20320	20321	20224		
E5	118416	BN	10	7.5									A	SUV1	119148	20252	20320	20321	20224		
													A	SUV1	119148	20252	20320	20321	20224		
													A	SUV1,2	119148	20252	20320	20321	20224		
E21	118786	BN,CH	45	5.7,5	X								A,E	SUV1,2						3073-P	10
E5	118416	BN	10	7.5									A	SUV1	119148	20252	20320	20321	20224		

A 2 wire system.
B 3 wire system. Converter required.
BN Exterior mounted plug on some or all models. May require an aftermarket electrical mounting box or bracket. (Sold separately)
BTT Shared Brake/Tail/Turn multiplexed wiring system. ModuLite® HD Plus or Ultra required.
CH T-One is equipped with circuit protected ModuLite® module.
E ModuLite® required.
H 3 wire system with OEM standard 2 wire harness.
HG T-One incorporates taillight converter.
RD For vehicles equipped with factory tow package may require additional components or may be used as a replacement harness.

RT2 Round Tube Class II 1-1/4"
RT3 Round Tube Class III 2"
RT4 Round Tube Class IV 2"
SQ1 Square Tube Class I
SQ2 Square Tube Class II
SQ3 Square Tube Class III

RECEIVER HITCH APPLICATION GUIDE

MODEL / STYLE	YEAR	TRAILER HITCHES									
		PC	REC TYPE	REC SIZE	PART NO.	NO DRILL	FOOTNOTES	OPTIONAL DRAWBAR	WC (LBS.)	WD (LBS.)	IN
JEEP (Continued)											
Wrangler JK Except w/Right Hand Drive, Hard Rock Edition, 75th Anniversary Edition & vehicles with Mopar Off Road Bumper #82213654	18	22	SQ2	1-1/4	364241	0	GP	36071	300/3,500	675/4,500	20
		10	SQ3	2	755151	0			675/4,500	675/4,500	20
Wrangler JK Right Hand Drive	18	11	SQ3	2	76104	0			675/4,500	675/4,500	20
Wrangler JK Right Hand Drive, Except Hard Rock Edition, 75th Anniversary Edition & vehicles with Mopar Off Road Bumper #82213654	18	22	SQ2	1-1/4	364241	0	GP	36071	300/3,500	675/4,500	20
		10	SQ3	2	755151	0			675/4,500	675/4,500	20
KIA											
Amanti	07-09										
Borrego w/Factory 7-Way	09-11										
Cadenza	14	28	RT2	1-1/4	36544		HM,JR	36061	300/3,500		20
Forte 4 Dr. Sedan	10-13	27	SQ1	1-1/4	24846	0	HM,JR	3594	200/2,000		20
Forte 4 Dr. Sedan	14-18	23	SQ1	1-1/4	24903	0	HM	3594	200/2,000		20
Forte Sedan	19-20	23	SQ1	1-1/4	24990	0	DU,EP	3593	200/2,000		40
Magentis (Canada Only)	01-04	44	SQ1	1-1/4	247091	0	GP	3593	200/2,000		15
Magentis (Canada Only)	06-10	29	SQ1	1-1/4	24778	0	HM,JR	3594	200/2,000		20
Niro Except Plug-In-Hybrid	17-19	28	SQ2	1-1/4	36600	0	GP,JR,EP,SV	36071	350/3,500		40
Optima	01-06	44	SQ1	1-1/4	247091	0	GP	3593	200/2,000		15
Optima (App. starts with 2006-1/2)	06-08	29	SQ1	1-1/4	24778	0	HM,JR	3594	200/2,000		20
Optima	09-10	29	SQ1	1-1/4	24778	0	HM,JR	3594	200/2,000		20
Optima	11-19	22	SQ1	1-1/4	24965	0	HM,JR,KH,SV	3593	200/2,000		40
Rio	02-05	33	SQ1	1-1/4	247271		TA,GP	3594	200/2,000		20
Rio 4 Dr. Sedan	06-11	32	SQ1	1-1/4	24760	0	GP	3590	200/2,000		20
Rio 4 Dr. Sedan, Except S	12-17	30	SQ1	1-1/4	24884	0	HM	3592	200/2,000		15
Rio 5 Dr. Hatchback	12-16	28	SQ1	1-1/4	24883	0	GP,JR,SV	3593	200/2,000		30
Rio Sedan	18-19										
Rio5 5 Dr. Hatchback	06-11	28	SQ1	1-1/4	24795	0	JR,X,GP	3594	200/2,000		25
Rondo	07-10	27	SQ1	1-1/4	24797	0	GP,JR	3594	200/2,000		30
Rondo (Canada Only)	11-12	27	SQ1	1-1/4	24797	0	GP,JR	3594	200/2,000		30
Rondo (Canada Only)	14-17	28	SQ2	1-1/4	36525	0	GP,JR,SV	36061	300/3,500		25
Sedona	02-05	41	SQ2	1-1/4	363051		HM	36071	300/3,500		20
		41	RT3	2	75131		HM		500/5,000	550/5,500	30
Sedona 118.9" Long Wheelbase	06-12	45	RT3	2	75421	0	HM,JR		350/3,500	400/4,000	20
Sedona 113.8" Short Wheelbase	07-10	45	RT3	2	75551	0	HM,JR		350/3,500	400/4,000	25
Sedona 118.9" Long Wheelbase	14	45	RT3	2	75421	0	HM,JR		350/3,500	400/4,000	20
Sedona	15-19	40	RT3	2	75894	0	HM,JR,SV		400/4,000	400/4,000	20
Sedona	18-19										
Sorento	03-06	29	RT3	2	75516	0	HM		500/5,000	500/5,000	15
Sorento	07-09	29	RT3	2	75516	0	HM		500/5,000	500/5,000	15
Sorento Base I4	11-13	25	SQ3	2	75684	0	HM		350/3,500	500/5,000	15
Sorento EX I4	11-13	25	SQ3	2	75684	0	HM		350/3,500	500/5,000	15
Sorento EX V6, Except w/Factory Tow Package	11-13	25	SQ3	2	75684	0	HM		350/3,500	500/5,000	15
Sorento EX V6, w/Factory Tow Package	11-13	29	SQ2	1-1/4	36511	0	HM	36051	300/3,500		15
		25	SQ3	2	75684	0	HM		350/3,500	500/5,000	15
Sorento Except SX V6 & EX V6 w/Factory Tow Package	11-13	29	SQ2	1-1/4	36511	0	HM	36051	300/3,500		15
Sorento LX I4	11-13	25	SQ3	2	75684	0	HM		350/3,500	500/5,000	15
Sorento LX V6	11-13	25	SQ3	2	75684	0	HM		350/3,500	500/5,000	15
Sorento SX V6	11-13	29	SQ2	1-1/4	36511	0	HM	36051	300/3,500		15
		25	SQ3	2	75684	0	HM		350/3,500	500/5,000	15
Sorento w/ I4 Engine	14-15	27	RT2	1-1/4	36536	0	HM,JJR,SV	36051	300/3,500		30
		28	RT3	2	75772	0	HM,JJR,SV		525/3,500	525/5,250	30

DU Fascia removal required.
EP Fascia trimming may be required.
GP Hitch cross-tube concealed behind bumper.
HM Hitch cross-tube is visible beneath bumper.
J Under vehicle spare tire stowage is retained.

JR Exhaust must be temporarily lowered for installation.
KH Minor heat shield modification may be required.
SV Trimming or removal of under body appearance panel may be required.
TA Trunk access required for hitch installation.
X Minor fascia trimming required.

T-ONE						TOW HARNESS						4-FLAT WIRING				REQ. 4 FLAT WIRING		7-WAY HARDWIRE	BRAKE CONTROL HARNESS	IN
PC	T-ONE	FN	IN	AMP	CP	PC	TOW HARN	FN	IN	AMP	CP	TYPE	ELEC	POS	CHOICE 1	CHOICE 2	6-WAY ADAPTER			
JEEP (Continued)																				
E5	118416	BN	10	7.5									A	SUV1	119148	20252	20320	20321	20224	
													A	SUV1	119148	20252	20320	20321	20224	
													A	SUV1.2	119148	20252	20320	20321	20224	
KIA																				
E10	118453	HG	10	2.1,7.5									B	PC3,4	119178	119130				
						E8	118384 74682 85219	BN,RD RD RD	5 10 5	7.5		4-Flat Both 7-Way	H	SUV6	119148	20252				
E15	118616	CH	45	2.1,5.6	X								B,E	PC3,4	119191	119148				
E12	118415	CG	20	2.1,5	X								B	PC3,4	119130	119178				
E15	118594	CH	45	2.1,5.6	X								B,E	PC3,4	119191	119148	20320	20321	20224	
													B,E	PC3,5,7	119191	119148	20320	20321	20224	
													B	PC3,4	119130	119178				
E15	118749	CH	45	4.2,7.5	X								B	PC3,4	119130	119178				
													B,E	PC3,4						
													B	PC3,4	119130	119178				
E7	118452		10	7.5									A	PC3,4	119148	20252				
E12	118433	CG	10	2.1,5	X								B	PC3,4	119130	119178				
E10	118453	HG	10	2.1,7.5									B	PC3,4	119130	119178				
													B	PC3,4	119130	119178				
													B	PC1,2	119130	119178				
E16	118570	CH	45	2.1,5.6	X								B,E	PC3,4	119191	119148				
E16	118570	CH	45	2.1,5.6	X								B,E	PC3,4	119191	119148				
E16	118793	CH	45	5.7,5	X								B,E	PC3,4	119191	119148				
													B	PC3,4	119130	119178				
E14	118431	BN,CG	15	2.1,5	X								B	SUV1.2	119130	119178	20320	20321		
E14	118431	BN,CG	15	2.1,5	X								B	SUV1.2	119130	119178	20320	20321		
													B,E	SUV1.2	119191	119148	20320	20321		
E10	118309	HG	25	2.1,5									B	SUV1.2	119130	119178	20320	20321	20224	
E19	118410	BN,CH	45	2.1,5.6	X								B,E	SUV1.2	119191	119148	20320	20321	20224	
E19	118410	BN,CH	45	2.1,5.6	X								B,E	SUV1.2	119191	119148	20320	20321	20224	
E19	118410	BN,CH	45	2.1,5.6	X								B,E	SUV1.2	119191	119148	20320	20321	20224	
E13	118269	BN,CH	20	4.2,7.5	X								B,E	SUV5	119191	119148	20320	20321	20224	
E13	118269	BN,CH	20	4.2,7.5	X								B,E	SUV5	119191	119148	20320	20321	20224	
E8	118307	BN,HG	5	2.1,5									B	SUV7	119130	119178	20320	20321	20224	
						E13	118269	CH,RD	20	4.2,7.5	X	4-Flat	B,E	SUV7	119191	119148	20320	20321	20224	
E23	118506	CH	45	4.2,7.5	X								B,E	SUV1.2	119191	119148	20320	20321	20224	
E23	118506	CH	45	4.2,7.5	X								B,E	SUV1.2	119191	119148	20320	20321	20224	
E23	118506	CH	45	4.2,7.5	X								B,E	SUV1.2	119191	119148	20320	20321	20224	
						E13	118269	BN,CH	20	4.2,7.5	X	4-Flat	B,E	SUV1.2	119191	119148	20320	20321	20224	
E23	118506	CH	45	4.2,7.5	X								B,E	SUV1.2	119191	119148	20320	20321	20224	
E23	118506	CH	45	4.2,7.5	X								B,E	SUV1.2	119191	119148	20320	20321	20224	
E23	118506	CH	45	4.2,7.5	X	E13	118269	BN,CH	20	4.2,7.5	X	4-Flat	B,E	SUV1.2	119191	119148	20320	20321	20224	
E13	118269	BN,CH	20	4.2,7.5	X	E13	118269	BN,CH	20	4.2,7.5	X	4-Flat	B,E	SUV1.2	119191	119148	20320	20321	20224	
E16	118583	BN,CH	45	4.2,7.5	X								B,E	SUV1.2	119191	119148	20320	20321	20224	

A 2 wire system.
B 3 wire system. Converter required.
BN Exterior mounted plug on some or all models. May require an aftermarket electrical mounting box or bracket. (Sold separately)
CG T-One incorporates circuit protected taillight converter.
CH T-One is equipped with circuit protected ModuLite® module.
E ModuLite® required.
H 3 wire system with OEM standard 2 wire harness.
HG T-One incorporates taillight converter.
RD For vehicles equipped with factory tow package may require additional components or may be used as a replacement harness.

RT2 Round Tube Class II 1-1/4"
RT3 Round Tube Class III 2"
SQ1 Square Tube Class I
SQ2 Square Tube Class II
SQ3 Square Tube Class III

RECEIVER HITCH APPLICATION GUIDE

MODEL / STYLE	YEAR	TRAILER HITCHES									
		PC	REC TYPE	REC SIZE	PART NO.	NO DRILL	FOOTNOTES	OPTIONAL DRAWBAR	WC (LBS.)	WD (LBS.)	IN
KIA (Continued)											
Sorento w/ V6 Engine	14-15	27	RT2	1-1/4	36536	0	HM,J,JR,SV	36051	300/3,500		30
		28	RT3	2	75772	0	HM,J,JR,SV		525/3,500	525/5,250	30
Sorento w/ I4 Engine	16-19	36	RT3	2	75908	0	HM,TA,JR		500/5,000		40
Sorento w/ V6 Engine	16-19	36	RT3	2	75908	0	HM,TA,JR		500/5,000		40
Soul Except w/LED Taillights	10-13	13	SQ1	1-1/4	24839	0	GP,JR	3593	200/2,000		40
Soul w/LED Taillights	10-13	13	SQ1	1-1/4	24839	0	GP,JR	3593	200/2,000		40
Soul Except w/LED Taillights	14-19	19	SQ1	1-1/4	24915	0	GP,JR	3593	200/2,000		40
Soul w/LED Taillights	14-19	19	SQ1	1-1/4	24915	0	GP,JR	3593	200/2,000		40
Soul	20	22	SQ1	1-1/4	24985	0	JR,X		200/2,000		30
Spectra Except Spectra5	05-09	31	SQ1	1-1/4	24743f	0	JR,HM	3593	200/2,000		20
Sportage	95-97	33	SQ2	1-1/4	36266f		HM	36051	300/3,500		20
Sportage	98-02	33	SQ2	1-1/4	36266f		HM	36051	300/3,500		20
Sportage 4 Cyl.	05-10	32	SQ2	1-1/4	36363	0	GP,JR	36051	300/3,500		25
		30	SQ3	2	75561	0	GP,JR		350/3,500		25
Sportage 6 Cyl.	05-10	32	SQ2	1-1/4	36363	0	GP,JR	36051	300/3,500		25
		30	SQ3	2	75561	0	GP,JR		350/3,500		25
Sportage	11-16	21	SQ2	1-1/4	36510	0	GP,JR	36051	300/3,500		20
		23	SQ3	2	75717	0	GP,JR		525/3,500	525/5,250	20
Sportage Except SX & SX Turbo	17-19	29	RT2	1-1/4	36593	0	GP,SV,JR,X	36071	300/3,500		30
		29	SQ3	2	76074	0	GP,SV,JR		675/4,500	675/4,500	25
Stinger	18	41	SQ1	1-1/4	24974	0	DJ,FE,JR,KH	3593	200/2,000		90
Telluride	20	38	SQ3	2	76403	0	JR,X		500/4,500	750/6,000	30
LAND ROVER											
Discovery Sport	15-19										
LR2	08-14	23	RT3	2	75688	0	HM		400/4,000	400/4,000	20
Range Rover	05-14										
Range Rover	15										
Range Rover Evoque Excluding Autobiography	12-14	25	SQ3	2	75227	0	EP,GP,X,KH		675/4,500		45
Range Rover Evoque Excluding Autobiography	15-19	25	SQ3	2	75227	0	EP,GP,X,KH		675/4,500		45
Range Rover Sport	14										
Range Rover Sport	15-17	41	SQ4	2	75229	0	GP,SV		800/8,000		45
Range Rover Velar	18-19	42	SQ3	2	76260	0	JR,TZ		900/6,000		80
LEXUS											
ES300 4 Dr.	97-01	33	SQ1	1-1/4	24563f	0	JR,HM	3593	200/2,000		30
		23	SQ2	1-1/4	36336		HM	36061	300/3,500		15
ES300 4 Dr.	02-03	23	SQ2	1-1/4	36336		HM	36061	300/3,500		15
ES330 4 Dr.	04-06	23	SQ2	1-1/4	36336		HM	36061	300/3,500		15
ES350	07-12	20	SQ2	1-1/4	36416		GP,JR,TA	36071	300/3,500		45
ES350 Except Hybrid	13-18	29	SQ2	1-1/4	36530		HM,JR	36071	300/3,500		40
GS350	13	32	SQ2	1-1/4	36535f	0	GP,EP,FE	36071	300/3,500		60
GS450h	13										
GX460	10-14	21	SQ3	2	75685	0			500/5,000	500/5,000	15
GX460 w/Factory 7-Way	10-11										
GX460	15	21	SQ3	2	75685	0			500/5,000	500/5,000	15
GX460	16-19	21	SQ3	2	75685	0			500/5,000	500/5,000	15
GX470	03-06	47	RT4	2	75155	0	LT,SI		600/6,000	730/7,300	35
GX470 w/Factory 7-Way	03-06										
GX470	07-09	47	RT4	2	75155	0	LT,SI		600/6,000	730/7,300	35
HS250h Hybrid	10-12	23	SQ1	1-1/4	24860f	0	HM,JR,KH	3594	200/2,000		25
IS250	09-13										
IS250 Except Convertible	14-15	25	RT1	1-1/4	24923	0	KH,AE,HM	3594	200/2,000		35

AE Requires temporary removal of muffler during installation.

DU Fascia removal required.

EP Fascia trimming may be required.

FE Fascia trimming may be required. Allow additional installation time.

GP Hitch cross-tube concealed behind bumper.

HM Hitch cross-tube is visible beneath bumper.

J Under vehicle spare tire stowage is retained.

JR Exhaust must be temporarily lowered for installation.

KH Minor heat shield modification may be required.

LT Requires removal of factory hitch if equipped.

SI Hitches produced before 07/31/07 are rated at 350/3500 WC & 500/5000 WD.

SV Trimming or removal of under body appearance panel may be required.

TA Trunk access required for hitch installation.

TZ Requires replacement of the impact structure with hitch.

X Minor fascia trimming required.

T-ONE						TOW HARNESS						4-FLAT WIRING				REQ. 4 FLAT WIRING		7-WAY HARDWARE	BRAKE CONTROL HARNESS	IN	
PC	T-ONE	FN	IN	AMP	CP	PC	TOW HARN	FN	IN	AMP	CP	TYPE	ELEC	POS	CHOICE 1	CHOICE 2	6-WAY ADAPTER				7-WAY ADAPTER
KIA (Continued)																					
E13	118269	BN,CH	20	4.2,7.5	X	E13	118269	BN,CH	20	4.2,7.5	X	4-Flat	B,E	SUV1,2	119191	119148	20320	20321	20224		
E16	118583	BN,CH	45	4.2,7.5	X								B,E	SUV5	119191	119148	20320	20321			
E13	118269	BN,CH	20	4.2,7.5	X								B,E	SUV5	119191	119148	20320	20321			
E14	118431	BN,CG	15	2.1,5	X								B	SUV1,2	119130	119178	20320	20321			
E17	118637	CH	45	2.1,5.6	X								B,E	SUV1,2	119191	119148	20320	20321			
E14	118431	BN,CG	15	2.1,5	X								B	SUV1,2	119130	119178	20320	20321			
E17	118637	CH	45	2.1,5.6	X								B,E	SUV1,2	119191	119148	20320	20321			
E19	118813		45	5.7,5	X								B,E	SUV1,2	119191	119148					
													B	PC3,4	119130	119178					
													B,E	SUV3,4	119191	119148					
		HG											B,E	SUV3,4	119191	119148					
													B	SUV1,2	119130	119178	20320	20321	20224		
E8	118401	BN,CG	5	2.1,5	X								B	SUV5	119130	119178	20320	20321	20224		
E25	118526	CH	45	4.2,7.5	X								B,E	SUV1,5	119191	119148	20320	20321	20224		
E17	118698	CH,BN	45	4.2,7.5	X								B,E	SUV1,5	119191	119148					
E18	118780	CH	45	5.7,5	X								B,E	PC3,4	119191	119148					
E11	118784	BN,CH	15	5.7,5	X								B,E	SUV5	119191	119148					
LAND ROVER																					
E16	118687	CH,BN	45	4.2,7.5	X								B,E	SUV1,2	119191	119148					
													B,E	SUV1,2	119191	119148	20320	20321	20224		
													A	SUV6	119148	20252				3035-P	
E1	118681	BN	10	4.2,7.5	X	E8	118275	BN	20			7-Way	A	SUV6	119148	20252				3035-P	
E1	118624	BN	10	7.5									A	SUV5	119148	20252				3035-P	
													A	SUV5	119148	20252				3035-P	
E1	118681		10	4.2,7.5	X								A	SUV6	119148	20252					
E1	118681		10	4.2,7.5	X	E8	118275	BN	20			7-Way	A	SUV6	119148	20252					
E16	118785	CH,BN	45	5.7,5	X								A,E	SUV1,2							
LEXUS																					
													E	PC3,4	119191	119148					
													E	PC3,4	119191	119148					
													E	PC3,4	119191	119148					
E16	118488	CH	45	2.1,5.6	X								B,E	PC3,4	119191	119148					
E17	118592	CH	45	2.1,5.6	X								B,E	PC3,4	119191	119148					
E17	118598	CH	45	2.1,5.6	X								B,E	PC3,4	119191	119148					
E17	118598	CH	45	2.1,5.6	X								B,E	PC3,4	119191	119148					
						E12	118262	BN,RD	10			Both	A	SUV5	119148	20252	20320				3040-P
E8	118384	BN,RD	5	7.5			74682	RD	10			Both	A	SUV5	119148	20252					
							85219	RD	5			7-Way									
													A	SUV5	119148	20252	20320				3040-P
													A	SUV5	119148	20252	20320				
													E	SUV1,2	119191	119148	20320	20321	20224	3040-P	
								RD					E	SUV1,2	119148	20252					
													E	SUV1,2	119191	119148	20320	20321	20224	3040-P	
E17	118510	CH	20	2.1,5.6	X								B,E	PC3,4	119191	119148					
E16	118609	CH	45	2.1,5.6	X								B,E	PC3,4	119191	119148					
													B,E	PC3,4	119191	119148					

A 2 wire system.
B 3 wire system. Converter required.
BN Exterior mounted plug on some or all models. May require an aftermarket electrical mounting box or bracket. (Sold separately)
CG T-One incorporates circuit protected taillight converter.
CH T-One is equipped with circuit protected ModuLite® module.
E ModuLite® required.
HG T-One incorporates taillight converter.
RD For vehicles equipped with factory tow package may require additional components or may be used as a replacement harness.

RT1 Round Tube Class I 1-1/4"
RT2 Round Tube Class II 1-1/4"
RT3 Round Tube Class III 2"
RT4 Round Tube Class IV 2"
SQ1 Square Tube Class I
SQ2 Square Tube Class II
SQ3 Square Tube Class III
SQ4 Square Tube Class IV

RECEIVER HITCH APPLICATION GUIDE

MODEL / STYLE	YEAR	TRAILER HITCHES									
		PC	REC TYPE	REC SIZE	PART NO.	NO DRILL	FOOTNOTES	OPTIONAL DRAWBAR	WC (LBS.)	WD (LBS.)	IN
LEXUS (Continued)											
IS350	09-13										
IS350	14	25	RT1	1-1/4	24923	0	KH,AE,HM	3594	200/2,000		35
IS350	15-19	25	RT1	1-1/4	24923	0	KH,AE,HM	3594	200/2,000		35
LX450	96-97	54	SQ3	2	41015	0	HM		500/5,000	750/6,000	30
LX470	98-99	45	SQ3	2	75095	0	GP		500/5,000	750/6,000	20
LX470	00	45	SQ3	2	75095	0	GP		500/5,000	750/6,000	20
LX470	01-02	45	SQ3	2	75095	0	GP		500/5,000	750/6,000	20
LX470	03-07	45	SQ3	2	75095	0	GP		500/5,000	750/6,000	20
NX200t	15-17	29	RT3	2	75956	0	JR,HM		350/3,500	400/4,000	35
NX300h	15										
RX300	99-00	39	SQ2	1-1/4	36271	0	HM	36051	300/3,500		15
		35	SQ3	2	41541	0	HM		300/3,500		15
RX300	01-03	39	SQ2	1-1/4	36271	0	HM	36051	300/3,500		15
		35	SQ3	2	41541	0	HM		300/3,500		15
RX330	04-06	32	RT3	2	75153	0	HM		350/3,500		20
RX350	07-09	32	RT3	2	75153	0	HM		350/3,500		20
RX350 Except F Sport	10-12	29	SQ3	2	75676	0	GP,JR,JV		400/4,000	500/5,000	30
RX350 Except F Sport	13-15	29	SQ3	2	75676	0	GP,JR,JV		400/4,000	500/5,000	30
RX350	16-19	26	SQ3	2	75540	0	GP,SV		675/4,500	675/4,500	20
RX350L	18	42	SQ3	2	76156	0	HM,SV		500/5,000		30
		36	RT4	2	75896	0	HM,SV		900/6,000	900/8,000	30
RX400h Hybrid	06-08	32	RT3	2	75153	0	HM		350/3,500		20
RX450h Hybrid	10-15	29	SQ3	2	75676	0	GP,JR,JV		400/4,000	500/5,000	30
RX450h	16-18	26	SQ3	2	75540	0	GP,SV		675/4,500	675/4,500	40
RX450h	19	26	SQ3	2	75540	0	GP,SV		675/4,500	675/4,500	40
LINCOLN											
Aviator	03-04	47	RT3	2	75132	0	HM,KL		500/5,000	800/8,000	20
Aviator w/Factory 7-Way	03-05										
Aviator	05	47	RT3	2	75132	0	HM,KL		500/5,000	800/8,000	20
Continental	88-02	35	SQ1	1-1/4	24699	0	GP,JR	3592	200/2,000		20
		35	SQ2	1-1/4	36252	0	GP,JR	36063	300/3,500		20
Continental	17-19	27	SQ2	1-1/4	36596	0	GP,JR,KH,SV	36071	300/3,500		50
LS	00-06	35	SQ2	1-1/4	36282†		FE,GP	36071	300/3,500		30
Mark LT (Built After 8/2005)	06-08	25	SQ4	2	75506	0	CP,HM		600/6,000	1,000/10,000	20
		40	SQ5	2	41933	0	@,CP,HM		1,200/12,000	1,400/14,000	20
Mark LT (Built Before 8/2005)	06	54	RT4	2	41549	0	HM,KM		600/6,000	1,000/10,000	30
		50	RT4	2	75156	0	HM,KM		600/6,000	800/8,000	30
Mark LT w/Factory 7-Way	06-08										
Mark VIII	93-98	41	SQ2	1-1/4	36179	0	GP,JR	36061	300/3,500		40
MKC	15-17	37	SQ2	1-1/4	36586	0	GP,JR	36061	300/3,500		45
		34	SQ3	2	75943	0	GP,JR		525/3,500		45
MKC	18-19	37	SQ2	1-1/4	36586	0	GP,JR	36061	300/3,500		45
		34	SQ3	2	75943	0	GP,JR		525/3,500		45
MKS	09-12	30	SQ2	1-1/4	36477	0	GP,JR	36051	300/3,500		30
MKS	13-16	30	SQ2	1-1/4	36477	0	GP,JR	36051	300/3,500		30
MKT	10-11	45	RT3	2	75679	0	HM,JR		400/4,000	400/4,000	30
MKT w/Factory 7-Way	10-12										
MKT	12-14	45	RT3	2	75679	0	HM,JR		400/4,000	400/4,000	30
MKT	15-17	45	RT3	2	75679	0	HM,JR		400/4,000	400/4,000	30

@ Ultra Frame ball mount must be used to achieve maximum weight carrying rating.
 AE Requires temporary removal of muffler during installation.
 CP Fits all models without factory installed receiver.
 FE Fascia trimming may be required. Allow additional installation time.
 GP Hitch cross-tube concealed behind bumper.
 HM Hitch cross-tube is visible beneath bumper.

JR Exhaust must be temporarily lowered for installation.
 JV Rubber air deflector/fascia must be removed or trimmed to install hitch.
 KH Minor heat shield modification may be required.
 KL Hitch is designed to attach beneath the OEM hitch.
 KM Does not work with models originally equipped with OEM hitch.
 SV Trimming or removal of under body appearance panel may be required.

T-ONE						TOW HARNESS						4-FLAT WIRING				REQ. 4 FLAT WIRING		7-WAY HARDWIRE	BRAKE CONTROL HARNESS	IN	
PC	T-ONE	FN	IN	AMP	CP	PC	TOW HARN	FN	IN	AMP	CP	TYPE	ELEC	POS	CHOICE 1	CHOICE 2	6-WAY ADAPTER				7-WAY ADAPTER
LEXUS (Continued)																					
E16	118609	CH	45	2.1,5.6	X								B,E	PC3,4	119191	119148					
E16	118609	CH	45	2.1,5.6	X								B,E	PC3,4	119191	119148					
													B,E	PC3,4	119191	119148					
E7	118357	BN,HG	5	2.1,5									B	SUV5	119130	119178	20320	20321	20224		
E7	118365	BN,HG	5	2.1,5									B	SUV6	119130	119178	20320	20321	20224		
													B	SUV6	119130	119178	20320	20321	20224		
						E3	118245	BN,RD	10	7.5		4-Flat	B	SUV6	119130	119178	20320	20321	20224		
						E3	118245	BN,RD	10	7.5		4-Flat	B	SUV6	119130	119178	20320	20321	20224	3040-P	5
E17	118652	CH	45	4.2,7.5	X								B,E	SUV3,4	119191	119148					
E17	118652	CH	45	4.2,7.5	X								B,E	SUV3,4	119191	119148					
													E,Z	SUV1,2	119191	119148	20320	20321	20224		
						E3	118245	BN,RD	10	7.5		4-Flat	E,Z	SUV1,2	119191	119148	20320	20321	20224		
E17	118478	CH	45	2.1,5.6	X								B,E	SUV1,2	119191	119148	20320	20321	20224		
E17	118478	CH	45	2.1,5.6	X								B,E	SUV1,2	119191	119148	20320	20321	20224		
E17	118478	CH	45	2.1,5.6	X	E3	118252	BN,RD	5	7.5		4-Flat	B,E	SUV3,4	119191	119148	20320	20321	20224		
E13	118255	CH,BN	20	2.1,5.6	X	E3	118252	BN,RD	5	7.5		4-Flat	B,E	SUV3,4	119191	119148	20320	20321	20224		
E13	118255	CH,BN	20	2.1,5.6	X	E3	118252	BN,RD	5	7.5		4-Flat	B,E	SUV3,4	119191	119148					
E13	118255	BN,CH	20	2.1,5.6	X	E3	118252	BN,RD	5	7.5		4-Flat									
													B,E	SUV1,2	119191	119148	20320	20321	20224		
E13	118255	BN,CH	20	2.1,5.6	X	E3	118252	BN,RD	5	7.5		4-Flat	B,E	SUV3,4	119191	119148	20320	20321	20224		
E13	118255	BN,CH	20	2.1,5.6	X	E3	118252	BN,RD	5	7.5		4-Flat	B,E	SUV3,4	119191	119148					
E13	118255	BN,CH	20	2.1,5.6	X								B,E	SUV3,4	119191	119148					
LINCOLN																					
E5	118344	BN	10	7.5									A	SUV1,2	119148	20252	20320	20321	20224		
							74682 85219	RD RD	10 5			Both 7-Way	A	SUV6	119148	20252					
													A	SUV1,2	119148	20252	20320	20321	20224		
													A,E	PC3,4	119191	119148					
E18	118682	CH	45	4.2,7.5	X								A,E	PC3,4							
E17	118373		20	2.1,4.2									G	PC3,4		119251					
													A	PU3	119148	20252	20320	20321	20224	3035-P	5
													A	PU3	119148	20252	20320	20321	20224	3035-P	5
							74682 85219	RD RD	10 5			Both 7-Way	A	PU3	119148	20252					
													E	PC3,4	119191	119148					
E14	118284	CH	45	5.7,5									B,E	SUV1,2	119191	119148	20320	20321	20224		
													B,E	SUV1,2	119191	119148	20320	20321	20224		
E18	118471	CH	45	2.1,5.6	X								B,E	PC3,4	119191	119148					
E15	118599	CH	45	2.1,5.6	X								B,E	PC3,4	119191	119148					
E18	118507	CH	45	2.1,5.6	X								A,E	SUV3,4	119191	119148	20320	20321	20224	3036-P	5
							74682 85219	RD RD	10 5			Both 7-Way	A	SUV6	119148	20252					
E18	118507	CH	45	2.1,5.6	X								A,E	SUV3,4	119191	119148	20320	20321	20224	3036-P	20
													A,E	SUV3,4	119191	119148	20320	20321	20224	3036-P	20

A 2 wire system.
B 3 wire system. Converter required.
BN Exterior mounted plug on some or all models. May require an aftermarket electrical mounting box or bracket. (Sold separately)
CH T-One is equipped with circuit protected ModuLite® module.
E ModuLite® required.

G Low-side switching system.
HG T-One incorporates taillight converter.
RD For vehicles equipped with factory tow package may require additional components or may be used as a replacement harness.
Z May be equipped with Factory Tow Prep Plug. Determine at time of installation.

RT1 Round Tube Class I 1-1/4"
RT3 Round Tube Class III 2"
RT4 Round Tube Class IV 2"
SQ1 Square Tube Class I
SQ2 Square Tube Class II
SQ3 Square Tube Class III
SQ4 Square Tube Class IV
SQ5 Square Tube Class V

RECEIVER HITCH APPLICATION GUIDE

MODEL / STYLE	YEAR	TRAILER HITCHES									
		PC	REC TYPE	REC SIZE	PART NO.	NO DRILL	FOOTNOTES	OPTIONAL DRAWBAR	WC (LBS.)	WD (LBS.)	IN
LINCOLN (Continued)											
MKX	07-10	33	SQ2	1-1/4	36447	0	GP, JR, KH	36051	300/3,500		45
		20	SQ3	2	75992		GP, KH, JR		400/4,000	400/4,000	55
MKX	11-15	20	SQ3	2	75992		GP, KH, JR		400/4,000	400/4,000	55
MKX	16-18	35	SQ3	2	75234	0	GP, TA, SV, JR, TW		675/4,500	675/4,500	45
MKZ	07-09	35	SQ1	1-1/4	24775		GP, JR, TA	3592	200/2,000		45
MKZ	10-12	25	SQ1	1-1/4	24865	0	GP, JR	3594	200/2,000		20
MKZ Except 3.0 Liter Engine	13-19	19	SQ1	1-1/4	24897	0	HM, SV	3594	200/2,000		20
Nautilus	19	35	SQ3	2	75234	0	GP, TA, SV, JR, TW		675/4,500	675/4,500	45
Navigator	98-02	42	SQ3	2	75071	0	GP		500/5,000	800/8,000	15
		41	SQ4	2	41527	0	GP		600/6,000	1,000/10,000	15
Navigator w/Factory 7-Way	98-12										
Navigator	03										
Navigator w/Factory 7-Way	13-14										
Navigator w/Factory 7-Way	15-17										
Town Car	81-02	36	SQ1	1-1/4	245261		CA, GP, HA	3592	200/2,000		25
Town Car	81-11	39	SQ2	1-1/4	36116		CA, GP, HA	36063	300/3,500		30
Town Car	90-11	38	SQ3	2	41116		AB, CA, EO, GP, HA		350/3,500	750/6,000	30
Zephyr	06	35	SQ1	1-1/4	24775		GP, JR, TA	3592	200/2,000		45
MAZDA											
2	11-14	28	SQ1	1-1/4	24869	0	GP, JR	3593	200/2,000		30
3 4 Dr. Sedan, Except w/Grand Touring LED Taillights	04-09	27	SQ1	1-1/4	24816		GP	3592	200/2,000		35
3 5 Dr. Hatchback, Except w/Grand Touring LED Taillights	04-09	27	SQ1	1-1/4	24816		GP	3592	200/2,000		35
3 4 Dr. Sedan, w/Grand Touring LED Taillights	06-09	27	SQ1	1-1/4	24816		GP	3592	200/2,000		35
3 5 Dr. Hatchback, w/Grand Touring LED Taillights	06-09	27	SQ1	1-1/4	24816		GP	3592	200/2,000		35
3 4 Dr. Sedan, Except w/Grand Touring LED Taillights	10-13	25	SQ1	1-1/4	24842	0	GP	3594	200/2,000		20
3 4 Dr. Sedan, w/Grand Touring LED Taillights	10-13	25	SQ1	1-1/4	24842	0	GP	3594	200/2,000		20
3 5 Dr. Hatchback, Except w/Grand Touring LED Taillights	10-13	20	SQ1	1-1/4	24843	0	GP	3594	200/2,000		15
3 5 Dr. Hatchback, w/Grand Touring LED Taillights	10-13	20	SQ1	1-1/4	24843	0	GP	3594	200/2,000		15
3 4 Dr. Sedan	14-17	25	RT1	1-1/4	24912	0	HM, JR	3593	200/2,000		15
3 5 Dr. Hatchback	14-18	24	SQ1	1-1/4	24914	0	HM, JR	3593	200/2,000		30
3 Hatchback	19						GP, SV				
		17	SQ1	1-1/4	24984		GP, JR, KH, SV		200/2,000		40
3 Sedan	19	24	SQ1	1-1/4	24982	0	GP, SV	3593	200/2,000		40
5	06-10	20	SQ1	1-1/4	24773		GP	3593	200/2,000		25
5	12-17	24	SQ1	1-1/4	24874		GP	3592	200/2,000		25
6 4 Dr. Sedan	03-08	35	SQ1	1-1/4	24775		GP, JR, TA	3594	200/2,000		45
6 5 Dr. Hatchback	04-08	35	SQ1	1-1/4	24775		GP, JR, TA	3594	200/2,000		45
6 Sport Wagon	04-07	16	SQ1	1-1/4	247851	0	TA, GP	3593	200/2,000		25
6 4 Dr. Sedan	09-13	25	SQ1	1-1/4	24832		GP, JR	3592	200/2,000		30
6 4 Dr. Sedan	14-19	25	SQ1	1-1/4	24908	0	HM	3594	200/2,000		30
B2300	94-97	24	SQ3	2	75082		EG, SD, GP		400/4,000	750/6,000	20
		50	SQ3	2	37136	0			500/5,000	600/6,000	40
B2300	02-09	24	SQ3	2	75082		SD, V, GP		400/4,000	750/6,000	20
		50	SQ3	2	37136	0			500/5,000	600/6,000	40
B2500	98-01	24	SQ3	2	75082		SD, V, GP		400/4,000	750/6,000	20
		50	SQ3	2	37136	0			500/5,000	600/6,000	40
B3000	94-97	24	SQ3	2	75082		EG, SD, GP		400/4,000	750/6,000	20
		50	SQ3	2	37136	0			500/5,000	600/6,000	40
B3000	98-01	24	SQ3	2	75082		SD, V, GP		400/4,000	750/6,000	20
		50	SQ3	2	37136	0			500/5,000	600/6,000	40

AB Requires four (4) 3/8 in. spacer blocks (#01077011) for installation. (Sold separately)
CA Models with dual exhaust require exhaust modification.
EG Relocation of spare tire bracket is not required. NOTE: 19mm open end style wrench must be purchased to allow removal of spare tire after hitch installation.
EO Requires longer ball mount.
GP Hitch cross tube concealed behind bumper.
HA External dress panel beneath 95-97 and 03-05 vehicles must be removed for hitch installation.
HM Hitch cross tube is visible beneath bumper.

JR Exhaust must be temporarily lowered for installation.
KH Minor heat shield modification may be required.
SD Hitches produced before 07/21/06 are rated at 350/3500 WC.
SV Trimming or removal of under body appearance panel may be required.
TA Trunk access required for hitch installation.
TW Receiver hitch may limit hands-free liftgate sensor range
V For vehicles with factory installed step bumpers only.

T-ONE						TOW HARNESS						4-FLAT WIRING				REQ. 4 FLAT WIRING		7-WAY HARDWARE	BRAKE CONTROL HARNESS	IN
PC	T-ONE	FN	IN	AMP	CP	PC	TOW HARN	FN	IN	AMP	CP	TYPE	ELEC	POS	CHOICE 1	CHOICE 2	6-WAY ADAPTER			
LINCOLN (Continued)																				
E17	118551	CH	45	4.2,7.5	X								N	SUV1,2		119251	20320	20321		
E23	118519	CH	45	4.2,7.5	X								N	SUV1,2		119251	20320	20321		
E18	118682	CH	45	4.2,7.5	X								A,E	SUV1,2	119191	119148				
E17	118502	CH	45	2.1,5.6	X								B,E	PC3,4	119191	119148				
E21	118543	CH,TR	45	2.1,5.6	X								B,E	PC3,4	119191	119148				
E17	118591	CH	45	2.1,5.6	X								A,E	PC1,2	119191	119148				
E23	118803	CH,BN	45	5.7,5	X								B,E	SUV1,2	119191	119148				
E5	118344	BN	10	7.5									A	SUV1,2	119148	20252	20320	20321	20224	3035-P 5
							74682 85219	RD RD	10 5			Both 7-Way	A	SUV6	119148	20252				3035-P 5
						E5	118344	BN	10	7.5		4-Flat	A	SUV1,2	119148	20252				
							74682 85219	RD RD	10 5			Both 7-Way	A	SUV6	119148	20252				3034-P 20
							74682 85219	RD RD	10 5			Both 7-Way	A	SUV6	119148	20252				3036-P 20
													A,E	PC3,4	119191	119148	20320	20321	20224	
													A,E	PC3,4	119191	119148	20320	20321	20224	
													A,E	PC3,4	119191	119148	20320	20321	20224	
E17	118502	CH	45	2.1,5.6	X								B,E	PC3,4	119191	119148				
MAZDA																				
E17	118520	CH	45	2.1,5.6	X								B,E	PC3,4	119191	119148				
E14	118420	CG	15	2.1,5	X								B	PC3,4	119130	119178				
E14	118420	CG	15	2.1,5	X								B	PC3,4	119130	119178				
													B,E	PC3,4	119191	119148				
													B,E	PC3,4	119191	119148				
E14	118420	CG	15	2.1,5	X								B	PC3,4	119130	119178				
													B,E	PC3,4	119191	119148				
E14	118420	CG	15	2.1,5	X								B	PC3,4	119130	119178				
													B,E	PC3,4	119191	119148				
E16	118405	CH	45	2.1,5.6	X								B,E	PC3,4	119191	119148				
E16	118405	CH	45	2.1,5.6	X								B,E	PC3,4	119191	119148				
E16	118808	CH	45	5.7,5	X								B,E	PC3,4	119191	119148				
E16	118808	CH	45	5.7,5	X								B,E	PC3,4	119191	119148				
E17	118520	CH	45	2.1,5.6	X								B,E	PC3,4	119191	119148		20321		
E17	118520	CH	45	2.1,5.6	X								B,E	PC3,4	119191	119148		20321		
E16	118405	CH	45	2.1,5.6	X								B,E	PC3,4	119191	119148				
E16	118405	CH	45	2.1,5.6	X								B,E	PC3,4	119191	119148				
E16	118405	CH	45	2.1,5.6	X								B,E	PC3,4	119191	119148				
E19	118483	CH	45	2.1,5.6	X								B,E	PC3,4	119191	119148				
E17	118587	CH	45	2.1,5.6	X								B,E	PC3,4	119191	119148				
E12	118325	BN,HG	5	2.1,5									B	PU3	119130	119178	20320	20321	20224	
E12	118325	BN,HG	5	2.1,5									B	PU3	119130	119178	20320	20321	20224	
E12	118325	BN,HG	5	2.1,5		E3	118241	BN,RD	5	7.5		4-Flat	B	PU3	119130	119178	20320	20321	20224	
E12	118325	BN,HG	5	2.1,5									B	PU3	119130	119178	20320	20321	20224	
E12	118325	BN,HG	5	2.1,5		E3	118241	BN,RD	5	7.5		4-Flat	B	PU3	119130	119178	20320	20321	20224	

- A** 2 wire system.
- B** 3 wire system. Converter required.
- BN** Exterior mounted plug on some or all models. May require an aftermarket electrical mounting box or bracket. (Sold separately)
- CG** T-One incorporates circuit protected taillight converter.
- CH** T-One is equipped with circuit protected ModuLite® module.
- CH,B**
- N**
- E** ModuLite® required.
- HG** T-One incorporates taillight converter.
- N** DO NOT cut or splice vehicle wiring. Only use approved T-One or see auto dealer for trailer tow wiring kit.
- RD** For vehicles equipped with factory tow package may require additional components or may be used as a replacement harness.
- TR** Trimming or Modification of the vehicle connector may be required.

- RT1** Round Tube Class I 1-1/4"
- SQ1** Square Tube Class I
- SQ2** Square Tube Class II
- SQ3** Square Tube Class III
- SQ4** Square Tube Class IV

MODEL / STYLE	YEAR	TRAILER HITCHES									
		PC	REC TYPE	REC SIZE	PART NO.	NO DRILL	FOOTNOTES	OPTIONAL DRAWBAR	WC (LBS.)	WD (LBS.)	IN
MAZDA (Continued)											
B3000	02-08	24	SQ3	2	75082	0	SD,V,GP		400/4,000	750/6,000	20
		50	SQ3	2	37136	0			500/5,000	600/6,000	40
B4000	94-97	24	SQ3	2	75082	0	EG,SD,GP		400/4,000	750/6,000	20
		50	SQ3	2	37136	0			500/5,000	600/6,000	40
B4000	98-01	24	SQ3	2	75082	0	SD,V,GP		400/4,000	750/6,000	20
		50	SQ3	2	37136	0			500/5,000	600/6,000	40
B4000	02-09	24	SQ3	2	75082	0	SD,V,GP		400/4,000	750/6,000	20
		50	SQ3	2	37136	0			500/5,000	600/6,000	40
CX-3	16-19	33	SQ1	1-1/4	24933	0	JR,GP	3593	200/2,000		25
CX-5	13-15	35	SQ3	2	75748†	0	GP,JR		525/3,500		40
CX-5	13-16	23	SQ2	1-1/4	36602†	0	GP,JR	36061	300/3,500		30
		23	SQ2	1-1/4	36601	0	GP,JR	36051	350/3,500		30
		24	SQ3	2	76138	0	GP,JR		675/4,500		20
CX-5	17-19	23	SQ2	1-1/4	36601	0	GP,JR	36051	350/3,500		20
		24	SQ3	2	76138	0	GP,JR		675/4,500		20
CX-7	07-12	34	SQ2	1-1/4	36419	0	GP,JR	36061	300/3,500		40
		29	SQ3	2	75512	0	GP,JR		350/3,500		40
CX-9	07-15	37	RT3	2	75531	0	HM		400/4,000	400/4,000	15
CX-9	16-17	24	SQ2	1-1/4	36772	0	SV,JR,GP	36071	300/3,500		30
		24	SQ3	2	76020	0	SV,JR,GP		675/4,500	675/4,500	30
CX-9	18-19	24	SQ2	1-1/4	36772	0	SV,JR,GP	36071	300/3,500		30
		24	SQ3	2	76020	0	SV,JR,GP		675/4,500	675/4,500	30
MPV Except w/Ground Effects	00-03	45	SQ3	2	75108	0			350/3,500	500/5,000	15
MPV w/Ground Effects	00-03	46	RT3	2	75507	0	HM,JR		350/3,500	500/5,000	20
MPV	04-06	46	RT3	2	75507	0	HM,JR		350/3,500	500/5,000	20
Protege	99-03	25	SQ1	1-1/4	24675†	0	HM	3593	200/2,000		20
Protege5	02-03	36	SQ1	1-1/4	24714†	0	JR,GP	3593	200/2,000		15
Tribute	01-03	36	RT3	2	75118	0	HM,KH		350/3,500	500/5,000	35
		50	SQ3	2	37136	0	KH		500/5,000	600/6,000	60
Tribute	04	36	RT3	2	75118	0	HM		350/3,500	500/5,000	35
		50	SQ3	2	37136	0			500/5,000	600/6,000	60
Tribute	05-06	22	SQ2	1-1/4	36501	0	HM	36051	300/3,500		20
		34	RT3	2	75751	0	HM		675/4,500	675/5,250	25
Tribute	08-11	22	SQ2	1-1/4	36501	0	HM	36051	300/3,500		20
		34	RT3	2	75751	0	HM		675/4,500	675/5,250	25
MERCEDES-BENZ											
C300 Sedan, Except Models w/Sport Package	15-19	27	SQ1	1-1/4	24953	0	DU,GP,SV	3593	200/2,000		75
GLA250	15-19	36	SQ3	2	75223	0	GP,JR,TA,KH,FE		350/3,500		90
GLC250	17-18										
GLC300 SUV, Except P03 Premium Package	16-19	27	SQ3	2	76082	0	JR,GP,KH,TA,AA,DU,T W		675/4,500		65
GLC300 SUV, with P03 Premium Package	16-19	27	SQ3	2	76082	0	JR,GP,KH,TA,AA,DU,T W		675/4,500		65
GLC350e	18										
GLC43 AMG	17-18										
GLC63 AMG	18										
GLC63 AMG S	18										
GLE350 Except w/Active Curve System	16-19	52	SQ4	2	76141	0	GP,JR,SV,KH		700/7,000	700/7,000	40
GLK350	10-12	56	RT3	2	75774	0	HM		600/4,000		20
GLK350	13-15	56	RT3	2	75774	0	HM		600/4,000		20
Metris	16-19	32	RT3	2	76015	0	HM		750/5,000	750/6,000	20
ML320	98-02	34	SQ3	2	75087	0			500/5,000	500/5,000	30
ML320 CDI Except w/Adaptive Variable Suspension	07-08	50	SQ3	2	75376		MB,TA		350/3,500	400/4,000	50

AA Requires temporary removal of bumper during installation.

DU Fascia removal required.

EG Relocation of spare tire bracket is not required. NOTE: 19mm open end style wrench must be purchased to allow removal of spare tire after hitch installation.

FE Fascia trimming may be required. Allow additional installation time.

GP Hitch cross-tube concealed behind bumper.

HM Hitch cross-tube is visible beneath bumper.

JR Exhaust must be temporarily lowered for installation.

KH Minor heat shield modification may be required.

MB Will not fit models equipped with air suspension package.

SD Hitches produced before 07/21/06 are rated at 350/3500 WC.

SV Trimming or removal of under body appearance panel may be required.

TA Trunk access required for hitch installation.

TW Receiver hitch may limit hands-free liftgate sensor range

V For vehicles with factory installed step bumpers only.

T-ONE					TOW HARNESS					4-FLAT WIRING				REQ. 4 FLAT WIRING		7-WAY HARDWIRE	BRAKE CONTROL HARNESS	IN	
PC	T-ONE	FN	IN	AMP	CP	PC	TOW HARN	FN	IN	AMP	CP	TYPE	ELEC	POS	CHOICE 1				CHOICE 2
MAZDA (Continued)																			
E12	118325	BN,HG	5	2.1,5									B	PU3	119130	119178	20320	20321	20224
E12	118325	BN,HG	5	2.1,5									B	PU3	119130	119178	20320	20321	20224
E12	118325	BN,HG	5	2.1,5	E3	118241	BN,RD	5	7.5			4-Flat	B	PU3	119130	119178	20320	20321	20224
E12	118325	BN,HG	5	2.1,5									B	PU3	119130	119178	20320	20321	20224
E14	118718	CH	45	5,7,5	X								B,E	SUV3,4	119191	119148			
E19	118563	CH	45	4,2,7,5	X								B,E	SUV3,4	119191	119148	20320	20321	20224
E19	118563	CH	45	4,2,7,5	X								B,E	SUV3,4	119191	119148			
E15	118746	CH	45	5,7,5	X										119191	119148			
E16	118405	CH	45	2.1,5,6	X	E12	118249	RD	5	2.1,4,2	X	4-Flat	B,E	SUV3,4	119191	119148	20320	20321	20224
E17	118520	CH	45	2.1,5,6	X								B,E	SUV3,4	119191	119148	20320	20321	20224
						E9	118278	CH	25		X	4-Flat	B,E	SUV3,4	119191	119148			
													B	SUV1,2	119130	119178	20320	20321	20224
													B	SUV1,2	119130	119178	20320	20321	20224
													B	SUV1,2	119130	119178	20320	20321	20224
													B	PC3,4	119130	119178			
													B	PC1,2	119130	119178			
E11	118343	HG,RW	10	2.1,5									B	SUV1,2	119130	119178	20320	20321	20224
													B,E	SUV1,2	119191	119148	20320	20321	20224
E17	118426	BN,CH	45	2.1,4,2	X								B,E	SUV1,2	119191	119148	20320	20321	20224
E17	118551	CH	45	4,2,7,5	X	E1	118251	BN,QP,RD	5	7.5		4-Flat	A	SUV1,2	119148	20252	20320	20321	20224
MERCEDES-BENZ																			
													A,E	PC3,4					
													B,E	SUV1,2	119191	119148			
E16	118747	CH	45	5,7,5	X								B,E	SUV1,2	119191	119148			
E16	118747	CH	45	5,7,5	X								B,E	SUV1,2	119191	119148			
													B,E	SUV1,2	119191	119148			
E16	118747	CH	45	5,7,5	X								B,E	SUV1,2	119191	119148			
E16	118747	CH	45	5,7,5	X								B,E	SUV1,2	119191	119148			
E16	118747	CH	45	5,7,5	X								B,E	SUV1,2	119191	119148			
E16	118747	CH	45	5,7,5	X								B,E	SUV1,2	119191	119148			
													B,E	SUV3,4	119191	119148	20320	20321	20224
													BT	SUV3,4	119251	119191	20320	20321	20224
													BM	SUV3,4	119251	119191	20320	20321	20224
													BTT	SUV1,2	119251	119191			
													E	SUV3	119191	119148	20320	20321	20224
													BM	SUV3,4	119251	119191	20320	20321	

- A** 2 wire system.
- B** 3 wire system. Converter required.
- BM** Multiplexed wiring system. ModuLite® HD Plus or Ultra required.
- BN** Exterior mounted plug on some or all models. May require an aftermarket electrical mounting box or bracket. (Sold separately)
- BT** Shared Brake/Tail multiplexed wiring system. ModuLite® HD Plus or Ultra required.
- BTT** Shared Brake/Tail/Turn multiplexed wiring system. ModuLite® HD Plus or Ultra required.
- CH** T-One is equipped with circuit protected ModuLite® module.
- E** ModuLite® required.
- HG** T-One incorporates taillight converter.
- QP** Will not fit vehicles with backup sensors built into rear bumper.
- RD** For vehicles equipped with factory tow package may require additional components or may be used as a replacement harness.
- RW** On some models it may require an upgraded flasher or ModuLite®.

- RT3** Round Tube Class III 2"
- SQ1** Square Tube Class I
- SQ2** Square Tube Class II
- SQ3** Square Tube Class III
- SQ4** Square Tube Class IV

MODEL / STYLE	YEAR	TRAILER HITCHES									
		PC	REC TYPE	REC SIZE	PART NO.	NO DRILL	FOOTNOTES	OPTIONAL DRAWBAR	WC (LBS.)	WD (LBS.)	IN
MERCEDES-BENZ (Continued)											
ML350 Except BlueTEC or w/Adaptive Variable Suspension	10-11	50	SQ3	2	75376		MB,TA		350/3,500	400/4,000	50
ML350 Except BlueTEC & w/Active Curve System	12-15	54	SQ3	2	75874†	0	GP,JP,KA,MB		525/3,500	525/4,000	30
ML350 Except w/Active Curve System	12-15	52	SQ4	2	76141	0	GP,JP,SV,KH		700/7,000	700/7,000	40
ML430	99-01	34	SQ3	2	75087	0			500/5,000	500/5,000	30
ML450 Hybrid, Except w/Adaptive Variable Suspension	10-11	50	SQ3	2	75376		MB,TA		350/3,500	400/4,000	50
ML500	02-05	34	SQ3	2	75087	0			500/5,000	500/5,000	30
ML500 Except w/Adaptive Variable Suspension	06-07	50	SQ3	2	75376		MB,TA		350/3,500	400/4,000	50
ML550 Except w/Adaptive Variable Suspension	08-11	50	SQ3	2	75376		MB,TA		350/3,500	400/4,000	50
R320 BlueTEC	09	43	SQ3	2	75470	0	SC		350/3,500		25
R320 BlueTEC w/Panoramic Roof Package	09	43	SQ3	2	75470		SC		350/3,500		50
R320 CDI	07-08	43	SQ3	2	75470	0	SC		350/3,500		25
R320 CDI w/Panoramic Roof Package	07-08	43	SQ3	2	75470		SC		350/3,500		50
R350	06-12	43	SQ3	2	75470	0	SC		350/3,500		25
R350 w/Panoramic Roof Package	06-12	43	SQ3	2	75470		SC		350/3,500		50
R500	06-07	43	SQ3	2	75470	0	SC		350/3,500		25
R500 w/Panoramic Roof Package	06-07	43	SQ3	2	75470		SC		350/3,500		50
Sprinter 144" & 170" Wheelbase, Except w/Factory Step Bumper	07-11	53	SQ4	2	75549	0	HM,UL		600/6,000	750/7,500	20
Sprinter w/Factory Step Bumper Excluding Models w/30-3/8" Frame Width	07-11	52	SQ3	2	75601	0	HM		500/5,000	750/7,500	30
Sprinter 144" & 170" Wheelbase, Except w/Factory Step Bumper	12-13	53	SQ4	2	75549	0	HM,UL		600/6,000	750/7,500	20
Sprinter w/Factory Step Bumper Excluding Models w/30-3/8" Frame Width	12-13	52	SQ3	2	75601	0	HM		500/5,000	750/7,500	30
Sprinter 144" & 170" Wheelbase, Except w/Factory Step Bumper	14-17	53	SQ4	2	75549	0	HM,UL		600/6,000	750/7,500	20
Sprinter w/Factory Step Bumper Excluding Models w/30-3/8" Frame Width	14-17	52	SQ3	2	75601	0	HM		500/5,000	750/7,500	30
Sprinter	18										
Sprinter 2500	07-09										
Sprinter 2500 144" & 170" Wheelbase, Except w/Factory Step Bumper	10-11	53	SQ4	2	75549	0	HM,UL		600/6,000	750/7,500	20
Sprinter 2500 w/Factory Step Bumper Excluding Models w/30-3/8" Frame Width	10-11	52	SQ3	2	75601	0	HM		500/5,000	750/7,500	30
Sprinter 2500 144" & 170" Wheelbase, Except w/Factory Step Bumper	12-13	53	SQ4	2	75549	0	HM,UL		600/6,000	750/7,500	20
Sprinter 2500 w/Factory Step Bumper Excluding Models w/30-3/8" Frame Width	12-13	52	SQ3	2	75601	0	HM		500/5,000	750/7,500	30
Sprinter 2500 144" & 170" Wheelbase, Except w/Factory Step Bumper	14-19	53	SQ4	2	75549	0	HM,UL		600/6,000	750/7,500	20
Sprinter 2500 w/Factory Step Bumper Excluding Models w/30-3/8" Frame Width	14-19	52	SQ3	2	75601	0	HM		500/5,000	750/7,500	30
Sprinter 2500	18-19										
Sprinter 3500	07-09										
Sprinter 3500 144" & 170" Wheelbase, Except w/Factory Step Bumper	10-11	53	SQ4	2	75549	0	HM,UL		600/6,000	750/7,500	20
Sprinter 3500 w/Factory Step Bumper Excluding Models w/30-3/8" Frame Width	10-11	52	SQ3	2	75601	0	HM		500/5,000	750/7,500	30
Sprinter 3500 144" & 170" Wheelbase, Except w/Factory Step Bumper	12-13	53	SQ4	2	75549	0	HM,UL		600/6,000	750/7,500	20
Sprinter 3500 w/Factory Step Bumper Excluding Models w/30-3/8" Frame Width	12-13	52	SQ3	2	75601	0	HM		500/5,000	750/7,500	30
Sprinter 3500 144" & 170" Wheelbase, Except w/Factory Step Bumper	14-19	53	SQ4	2	75549	0	HM,UL		600/6,000	750/7,500	20

GP Hitch cross-tube concealed behind bumper.
HM Hitch cross-tube is visible beneath bumper.
JR Exhaust must be temporarily lowered for installation.
KA Gasoline engine models only.
KH Minor heat shield modification may be required.

MB Will not fit models equipped with air suspension package.
SC Minor trimming of plastic trunk pan required.
SV Trimming or removal of under body appearance panel may be required.
TA Trunk access required for hitch installation.
UL This hitch will not fit a Sprinter single or dual rear-wheel vehicle with a 30-3/8 in. wide frame measured outside of frame to outside of frame.

T-ONE					TOW HARNESS							4-FLAT WIRING				REQ. 4 FLAT WIRING		7-WAY HARDWARE	BRAKE CONTROL HARNESS	IN		
PC	T-ONE	FN	IN	AMP	CP	PC	TOW HARN	FN	IN	AMP	CP	TYPE	ELEC	POS	CHOICE 1	CHOICE 2	6-WAY ADAPTER				7-WAY ADAPTER	
MERCEDES-BENZ (Continued)																						
													BM	SUV3,4	119251	119191	20320	20321	20224			
													A,E	SUV3,4	119191	119148	20320	20321	20224	3066-P	5	
													A,E	SUV3,4	119191	119148	20320	20321	20224	3066-P	5	
													E	SUV3	119191	119148	20320	20321	20224			
													BM	SUV3,4	119251	119191	20320	20321	20224			
													E	SUV3	119191	119148	20320	20321	20224			
													BT	SUV3,4	119251	119191	20320	20321				
													BM	SUV3,4	119251	119191	20320	20321				
													BM	SUV3,4	119251	119191	20320	20321				
													BM	SUV3,4	119251	119191	20320	20321				
													BM	SUV3,4	119251	119191	20320	20321				
													BM	SUV3,4	119251	119191	20320	20321				
													BT	SUV3,4	119251	119191	20320	20321				
													BT	SUV3,4	119251	119191	20320	20321				
													BT	SUV3,4	119251	119191	20320	20321				
													BT	SUV3,4	119251	119191	20320	20321				
E17	118650	CH	45	5,7.5	X								B,E	SUV1,2	119191	119148	20320	20321	20224	3063-P	10	
E17	118650	CH	45	5,7.5	X								B,E	SUV1,2	119191	119148	20320	20321	20224	3063-P	10	
E17	118650	CH	45	5,7.5	X								B,E	SUV1,2	119191	119148	20320	20321	20224	3030-P	10	
E17	118650	CH	45	5,7.5	X								B,E	SUV1,2	119191	119148	20320	20321	20224	3030-P	10	
E19	118649	CH	45	5,7.5	X		22115		90			7-Way	BT	SUV3,4	119251	119191	20320	20321	20224	3030-P	10	
E19	118649	CH	45	5,7.5	X		22115		90			7-Way	BT	SUV3,4	119251	119191	20320	20321	20224	3030-P	10	
																					3030-P	10
																					3063-P	10
E17	118650	CH	45	5,7.5	X								B,E	SUV3,4	119192	119191	20320	20321	20224	3063-P	10	
E17	118650	CH	45	5,7.5	X								B,E	SUV3,4	119192	119191	20320	20321	20224	3063-P	10	
E17	118650	CH	45	5,7.5	X								B,E	SUV3,4	119192	119191	20320	20321	20224	3030-P	10	
E17	118650	CH	45	5,7.5	X								B,E	SUV3,4	119192	119191	20320	20321	20224	3030-P	10	
E19	118649	CH	45	5,7.5	X		22115		90			7-Way	BT	SUV3,4	119251	119191	20320	20321	20224	3030-P	10	
E19	118649	CH	45	5,7.5	X		22115		90			7-Way	BT	SUV3,4	119251	119191	20320	20321	20224	3030-P	10	
																					3030-P	10
																					3063-P	10
E17	118650	CH	45	5,7.5	X								B,E	SUV3,4	119192	119191	20320	20321	20224	3063-P	10	
E17	118650	CH	45	5,7.5	X								B,E	SUV3,4	119192	119191	20320	20321	20224	3063-P	10	
E17	118650	CH	45	5,7.5	X								B,E	SUV3,4	119192	119191	20320	20321	20224	3030-P	10	
E17	118650	CH	45	5,7.5	X								B,E	SUV3,4	119192	119191	20320	20321	20224	3030-P	10	
E19	118649	CH	45	5,7.5	X		22115		90			7-Way	BT	SUV3,4	119251	119191	20320	20321	20224	3030-P	10	

A 2 wire system.
B 3 wire system. Converter required.
BM Multiplexed wiring system. ModuLite® HD Plus or Ultra required.
BT Shared Brake/Tail multiplexed wiring system. ModuLite® HD Plus or Ultra required.
CH T-One is equipped with circuit protected ModuLite® module.
E ModuLite® required.

SQ3 Square Tube Class III
SQ4 Square Tube Class IV

MERCEDES-BENZ

RECEIVER HITCHES

MODEL / STYLE	YEAR	TRAILER HITCHES									
		PC	REC TYPE	REC SIZE	PART NO.	NO DRILL	FOOTNOTES	OPTIONAL DRAWBAR	WC (LBS.)	WD (LBS.)	IN
MERCEDES-BENZ (Continued)											
Sprinter 3500 w/Factory Step Bumper Excluding Models w/30-3/8" Frame Width	14-19	52	SQ3	2	75601	0	HM		500/5,000	750/7,500	30
Sprinter 3500	18-19										
MERCURY											
Cougar	96-97	41	SQ2	1-1/4	36179	0	GP	36063	300/3,500		40
Grand Marquis	92-97	36	SQ1	1-1/4	245261		CA,GP	3592	200/2,000		25
		39	SQ2	1-1/4	36116		CA,GP	36063	300/3,500		30
		38	SQ3	2	41116		CA,GP		350/3,500	750/6,000	30
Grand Marquis	98-11	36	SQ1	1-1/4	245261		CA,GP	3592	200/2,000		25
		39	SQ2	1-1/4	36116		CA,GP	36063	300/3,500		30
		38	SQ3	2	41116		CA,GP		350/3,500	750/6,000	30
Marauder	03-04	36	SQ1	1-1/4	245261		CA,GP	3592	200/2,000		25
		39	SQ2	1-1/4	36116		CA,GP	36063	300/3,500		30
		38	SQ3	2	41116		CA,GP		350/3,500	750/6,000	30
Mariner	05-07	22	SQ2	1-1/4	36501		HM	36051	300/3,500		20
		34	RT3	2	75751	0	HM		675/4,500	675/5,250	25
Mariner	08-11	22	SQ2	1-1/4	36501		HM	36051	300/3,500		20
		34	RT3	2	75751	0	HM		675/4,500	675/5,250	25
Milan	06-09	35	SQ1	1-1/4	24775		GP,JR,TA	3592	200/2,000		45
Milan	10-11	25	SQ1	1-1/4	24865	0	GP,JR	3594	200/2,000		20
Montego	05-07	33	SQ2	1-1/4	36360	0	GP,JR	36071	300/3,500		30
		42	SQ3	2	75299	0	JR		350/3,500	400/4,000	30
Monterey	04-07	41	SQ2	1-1/4	36318	0	GP,JR	36071	300/3,500		25
		45	SQ3	2	75158	0	GP,JR		350/3,500	500/5,000	30
Mountaineer	97-01	32	SQ2	1-1/4	36246	0	HM	36051	300/3,500		15
		34	RT3	2	75083	0	JF,HM		500/5,000	600/6,000	15
		31	SQ3	2	75096	0	HM		500/5,000	750/7,500	15
Mountaineer w/Factory 7-Way	00-10										
Mountaineer	02-03	47	RT3	2	75132	0	HM,KL		500/5,000	800/8,000	20
Mountaineer	04-05	47	RT3	2	75132	0	HM,KL		500/5,000	800/8,000	20
Mountaineer w/1-1/4" Receivers	06-07	39	RT3	2	75437	0	HM,KL		500/5,000	800/8,000	25
Mountaineer w/1-1/4" Receivers	08-10	39	RT3	2	75437	0	HM,KL		500/5,000	800/8,000	25
Sable Sedan	96-99	35	SQ1	1-1/4	24699	0	GP,JR	3593	200/2,000		20
		35	SQ2	1-1/4	36252	0	GP,JR	36063	300/3,500		20
Sable Wagon	96-99	35	SQ1	1-1/4	24699	0	GP,JR	3593	200/2,000		20
		35	SQ2	1-1/4	36252	0	GP,JR	36063	300/3,500		20
Sable Sedan	00-03	35	SQ1	1-1/4	24699	0	GP,JR	3592	200/2,000		20
		35	SQ2	1-1/4	36252	0	GP,JR	36063	300/3,500		20
		47	SQ2	1-1/4	36313	0	GP,JR	36061	300/3,500		40
Sable Wagon	00-03	35	SQ1	1-1/4	24699	0	GP,JR	3592	200/2,000		20
		35	SQ2	1-1/4	36252	0	GP,JR	36063	300/3,500		20
		47	SQ2	1-1/4	36313	0	GP,JR	36061	300/3,500		40
Sable Sedan	04-05	47	SQ2	1-1/4	36313	0	GP,JR	36061	300/3,500		40
Sable Wagon	04-05	47	SQ2	1-1/4	36313	0	GP,JR	36061	300/3,500		40
Sable Sedan	08-09	33	SQ2	1-1/4	36360	0	GP,JR	36071	300/3,500		30
		42	SQ3	2	75299	0	JR		350/3,500	400/4,000	30
Villager	93-97	41	SQ2	1-1/4	362611	0	JR,GP	36061	300/3,500		15
		42	SQ3	2	75089	0	JR		350/3,500	500/5,000	15
Villager	98	41	SQ2	1-1/4	362611	0	JR,GP	36061	300/3,500		15
		42	SQ3	2	75089	0	JR		350/3,500	500/5,000	15
Villager	99-02	34	SQ2	1-1/4	362771	0	JR,GP	36061	300/3,500		15
		41	SQ3	2	751021	0	JR		350/3,500	500/5,000	15

CA Models with dual exhaust require exhaust modification.
 GP Hitch cross-tube concealed behind bumper.
 HM Hitch cross-tube is visible beneath bumper.
 JF Will not fit with 16 in. spare tire.

JR Exhaust must be temporarily lowered for installation.
 KL Hitch is designed to attach beneath the OEM hitch.
 TA Trunk access required for hitch installation.

T-ONE						TOW HARNESS						4-FLAT WIRING				REQ. 4 FLAT WIRING		7-WAY HARDWARE	BRAKE CONTROL HARNESS	IN	
PC	T-ONE	FN	IN	AMP	CP	PC	TOW HARN	FN	IN	AMP	CP	TYPE	ELEC	POS	CHOICE 1	CHOICE 2	6-WAY ADAPTER				7-WAY ADAPTER
MERCEDES-BENZ (Continued)																					
E19	118649	CH	45	5.7.5	X		22115		90			7-Way	BT	SUV3,4	119251	119191	20320	20321	20224	3030-P	10
																				3030-P	10
MERCURY																					
E9	118326		20	7.5									A,E	PC3,4	119191	119148	20320	20321	20224		
													A,E	PC3,4	119191	119148	20320	20321	20224		
													A,E	PC3,4	119191	119148	20320	20321	20224		
E17	118551	CH	45	4.2,7.5	X								A,E	SUV1,2	119191	119148	20320	20321	20224		
E17	118551	CH	45	4.2,7.5	X	E1	118251	BN,QP,RD	5	7.5		4-Flat	A	SUV1,2	119148	20252	20320	20321	20224		
E17	118502	CH	45	2.1,5.6	X								B,E	PC3,4	119191	119148					
E17	118502	CH	45	2.1,5.6	X								B,E	PC3,4	119191	119148					
													B,E	PC3,4	119191	119148	20320	20321	20224		
E17	118385	CH	45	2.1,5.6	X								N	SUV1,2		119251	20320	20321			
E16	118345	BN,CH	45	2.1,4.2		E3	118241	BN,RD	5	7.5		4-Flat	B,E	SUV1,2	119191	119148	20320	20321	20224		
							74682 85219	RD RD	10 5			Both 7-Way	A	SUV6	119148	20252					
E5	118344	BN	10	7.5									A	SUV1,2	119148	20252	20320	20321	20224	3035-P	5
													A	SUV1,2	119148	20252	20320	20321	20224	3035-P	5
													A	SUV1,2	119148	20252	20320	20321	20224	3035-P	5
													B	SUV1,2	119130	119178	20320	20321	20224	3035-P	5
E9	118333	HG	10	2.1,5									B	PC3,4	119130	119178					
													B	PC3,4	119130	119178					
E4	118375		10	7.5									A	PC3,4	119148	20252					
													A	PC3,4	119148	20252					
													B	PC3,4	119130	119178					
													A	PC3,4	119148	20252					
E7	118447		10	7.5									A	PC3,4	119148	20252	20320	20321	20224		
													B	SUV1,2	119130	119178	20320	20321	20224		
E10	118362	BN,HG	5	2.1,5									B	SUV1,2	119130	119178	20320	20321	20224		
													B	SUV1,2	119130	119178	20320	20321	20224		

A 2 wire system.
B 3 wire system. Converter required.
BN Exterior mounted plug on some or all models. May require an aftermarket electrical mounting box or bracket. (Sold separately)
BT Shared Brake/Tail multiplexed wiring system. ModuLite® HD Plus or Ultra required.
CH T-One is equipped with circuit protected ModuLite® module.

E ModuLite® required.
HG T-One incorporates taillight converter.
N DO NOT cut or splice vehicle wiring. Only use approved T-One or see auto dealer for trailer tow wiring kit.
QP Will not fit vehicles with backup sensors built into rear bumper.
RD For vehicles equipped with factory tow package may require additional components or may be used as a replacement harness.

RT3 Round Tube Class III 2"
SQ1 Square Tube Class I
SQ2 Square Tube Class II
SQ3 Square Tube Class III

MERCURY

RECEIVER HITCHES

MODEL / STYLE	YEAR	TRAILER HITCHES									
		PC	REC TYPE	REC SIZE	PART NO.	NO DRILL	FOOTNOTES	OPTIONAL DRAWBAR	WC (LBS.)	WD (LBS.)	IN
MINI											
Cooper Countryman Except John Cooper Works Model	11-16	37	SQ1	1-1/4	24934	0	DU,GP,X	3593	200/2,000		70
MITSUBISHI											
Eclipse	06-12	24	SQ1	1-1/4	24754		TA,GP	3592	200/2,000		30
Eclipse Cross	18-19	40	RT3	2	76244	0			675/4,500		20
Endeavor	04-05	37	RT3	2	75163	0	JR		350/3,500	500/5,000	20
Endeavor	06-08	41	SQ3	2	75519	0	JR		350/3,500		25
Endeavor	10-11										
Galant	07-12	19	SQ1	1-1/4	24835	0	JR,KH,HM	3593	200/2,000		30
L200 w/Factory Step Bumper	15-16	33	SQ4	2	76114	0	AA		750/7,500	750/7,500	45
Lancer 4 Dr. Sedan, Except Evolution, Ralliart & w/Dual Exhaust	08-11	27	SQ1	1-1/4	24885	0	GP,JR	3593	200/2,000		25
Lancer 5 Dr. Hatchback, Except Ralliart & w/Dual Exhaust	10-14	27	SQ1	1-1/4	24885	0	GP,JR	3593	200/2,000		25
Lancer 4 Dr. Sedan, Except Evolution, Ralliart & w/Dual Exhaust	12-17	27	SQ1	1-1/4	24885	0	GP,JR	3593	200/2,000		25
Lancer 4 Dr. Sedan, Except Evolution, Ralliart & w/Dual Exhaust	17										
Mirage	14-15	27	SQ1	1-1/4	24916	0	HM,JR	3593	200/2,000		20
Mirage Except Mirage G4	17	27	SQ1	1-1/4	24916	0	HM,JR	3593	200/2,000		20
Mirage Except Mirage G4	18										
Mirage G4	17										
Montero Except Montero Sport	01-06	46	SQ3	2	75116	0	KH		500/5,000	550/5,500	20
Montero Sport	97-04	35	SQ3	2	75075	0	GP		500/5,000	550/5,500	20
Outlander	03-06	30	SQ1	1-1/4	24732	0	KH,GP	3591	200/2,000		40
Outlander	07-10	44	SQ3	2	75555	0	HM,JR		400/4,000	400/4,000	25
Outlander Except Outlander Sport	11-13	44	SQ3	2	75555	0	HM,JR		400/4,000	400/4,000	25
Outlander Except Outlander Sport	14-15	36	RT3	2	75888	0	HM,JR		600/4,000	600/4,000	30
Outlander Except Outlander Sport Except Outlander Sport or PHEV	16-19	36	RT3	2	75888	0	HM,JR		600/4,000	600/4,000	30
Outlander Sport Except PHEV	11-19	25	RT2	1-1/4	36509	0	HM	36051	300/3,500		30
		25	RT3	2	76098	0			675/4,500		20
Raider	06-09	27	SQ3	2	75251	0	HM		500/5,000	800/8,000	20
Raider w/Factory 7-Way	06-09										
RVR (Canada Only)	11-14	25	RT2	1-1/4	36509	0	HM	36051	300/3,500		30
RVR (Canada Only)	11-17	25	RT3	2	76098	0			675/4,500		30
Triton w/Factory Step Bumper	15-16	33	SQ4	2	76114	0	AA		750/7,500	750/7,500	45
NISSAN											
Altima	93-97	39	SQ1	1-1/4	24690	0	HM,JR	3593	200/2,000		20
Altima	98-01	39	SQ1	1-1/4	24690	0	HM,JR	3593	200/2,000		20
Altima	02-06	30	SQ1	1-1/4	24788	0	JR,TA,GP	3592	200/2,000		30
Altima Sedan	07-15	15	SQ1	1-1/4	24796		AE,HM,TA	3594	200/2,000		45
Altima Coupe, Except SR Models	08-13	28	SQ1	1-1/4	24801	0	HM	3594	200/2,000		30
Altima Sedan	16-19	15	SQ1	1-1/4	24796		AE,HM,TA	3594	200/2,000		45
Armada	05-07	38	RT4	2	75741	0	HM		600/6,000	1,000/10,000	15
Armada w/Factory 7-Way	05-14										
Armada	08-14	35	RT4	2	75644	0	HM		600/6,000	1,000/10,000	15
Cube	09-13	20	SQ1	1-1/4	24845		HM,JR	3593	200/2,000		45
Frontier	98-04	41	SQ3	2	75186		GP		400/4,000	550/5,500	30
		50	SQ3	2	37136				500/5,000	600/6,000	35
Frontier	05-19										
		20	SQ3	2	75282	0	GP,TE		750/5,000	800/8,000	30
Frontier w/Factory Tow Package	05-19										
JUKE AWD, Except Nismo & Nismo RS	11-17	27	SQ1	1-1/4	24867	0	HM,JR	3593	200/2,000		40

AA Requires temporary removal of bumper during installation.

AE Requires temporary removal of muffler during installation.

DU Fascia removal required.

GP Hitch crosstube concealed behind bumper.

HM Hitch crosstube is visible beneath bumper.

JR Exhaust must be temporarily lowered for installation.

KH Minor heat shield modification may be required.

TA Trunk access required for hitch installation.

TE Hitches produced before 04/20/11 are rated at 500/5000 WC.

X Minor fascia trimming required.

T-ONE						TOW HARNESS						4-FLAT WIRING				REQ. 4 FLAT WIRING		7-WAY HARDWARE	BRAKE CONTROL HARNESS	IN
PC	T-ONE	FN	IN	AMP	CP	PC	TOW HARN	FN	IN	AMP	CP	TYPE	ELEC	POS	CHOICE 1	CHOICE 2	6-WAY ADAPTER			
MINI																				
													B,E	SUV3,4	119191	119148				
MITSUBISHI																				
													E	PC3,4	119191	119148				
													B,E	SUV3						
E12	118516		30	2.1,5.6	X								B,E	SUV1,2	119191	119148	20320	20321	20224	
E12	118516		30	2.1,5.6	X								B,E	SUV1,2	119191	119148	20320	20321	20224	
E12	118516	CH	30	2.1,5.6	X								B,E	SUV3	119191	119148				
E14	118420	CG	15	2.1,5	X								B	PC3,4	119130	119178				
														PU3						
													B,E	PC3,4	119191	119148				
E16	118538		45	2.1,5.6	X								B,E	PC1,2	119191	119148				
E16	118538		45	2.1,5.6	X								B,E	PC3,4	119191	119148				
E16	118538		45	2.1,5.6	X								B,E	PC3,4	119191	119148				
E15	118769	CH	45	5.7,5	X								B,E	PC3,4	119191	119148				
E15	118769	CH	45	5.7,5	X								B,E	PC3,4	119191	119148				
E15	118769	CH	45	5.7,5	X								B,E	PC3,4	119191	119148				
E15	118769	CH	45	5.7,5	X								B,E	PC3,4	119191	119148				
E12	118380	BN,HG	20	2.1,5									B	SUV1,2	119130	119178	20320	20321	20224	
													B	SUV1,2	119130	119178	20320	20321	20224	
E10	118306		25	2.1,5									B,E	SUV3,4	119191	119148				
E18	118518	CH	45	4.2,7.5	X								B,E	SUV3,4	119191	119148	20320	20321	20224	
E18	118518	CH	45	4.2,7.5	X								B,E	SUV3,4	119191	119148	20320	20321	20224	
E17	118482	CH	45	2.1,5.6	X								B,E	SUV3,4	119191	119148	20320	20321	20224	
E17	118482	CH	45	2.1,5.6	X	E12	118277	CH,BN	45	4.2,7.5	X	4-Flat	B,E	SUV3,4	119191	119148	20320	20321	20224	
E16	118538	CH	45	2.1,5.6	X								B,E	SUV1,2	119191	119148				
E7	118323	BN,HJ	10	7.5		E3	118381	BN,RD	5	7.5		4-Flat	A	PU1,2	119148	20252	20320	20321	20224	
							20135	RD	10			Both	A	PU3	119148	20252				
E16	118538	CH	45	2.1,5.6	X								B,E	SUV1,2	119191	119148	20320	20321		
E16	118538	CH	45	2.1,5.6	X								B,E	SUV1,2	119191	119148	20320	20321		
														PU3						
NISSAN																				
E10	118361	HG	20	2.1,5									B	PC3,4	119130	119178				
													B	PC3,4	119130	119178				
													B,E	PC3,4	119191	119148				
E17	118470	CH	45	2.1,5.6	X								B,E	PC3,4	119191	119148				
E17	118470	CH	45	2.1,5.6	X								B	PC3,4	119130	119178				
E15	118731	CH	45	5.7,5	X								B,E	PC3,4	119191	119148				
						E8	118384	BN,RD	5	7.5		4-Flat	A	SUV6	119148	20252	20320	20321	20224	3050-P
							74682	RD	10			Both	H	SUV6	119148	20252				
							85219	RD	5			7-Way								
						E8	118384	BN,RD	5	7.5		4-Flat	A	SUV6	119148	20252	20320	20321	20224	3050-P
E15	118492	CG	45	2.1,7.5	X								B	SUV1,2	119130	119178	20320	20321		
E10	118362	BN,HG	5	2.1,5									B	PU4	119130	119178	20320	20321	20224	
						E21	118266	BN,RD	30			7-Way	H	PU3	119148	20252				3050-P
						E9	118267	BN,RD,Z	30			7-Way	B,E	PU3	119191	119148				3050-P
E17	118528	CH	45	2.1,5.6	X								B,E	SUV3,4	119191	119148	20320	20321		

- A** 2 wire system.
- B** 3 wire system. Converter required.
- BN** Exterior mounted plug on some or all models. May require an aftermarket electrical mounting box or bracket. (Sold separately)
- CG** T-One incorporates circuit protected taillight converter.
- CH** T-One is equipped with circuit protected ModuLite® module.
- E** ModuLite® required.
- H** 3 wire system with OEM standard 2 wire harness.
- HG** T-One incorporates taillight converter.
- HJ** Per Dodge owner's manual: If trailer is equipped with more than standard lighting (1 taillight per side) use of ModuLite® or dealer supplied harness is required.
- RD** For vehicles equipped with factory tow package may require additional components or may be used as a replacement harness.
- Z** May be equipped with Factory Tow Prep Plug. Determine at time of installation.

- RT2** Round Tube Class II 1-1/4"
- RT3** Round Tube Class III 2"
- RT4** Round Tube Class IV 2"
- SQ1** Square Tube Class I
- SQ3** Square Tube Class III
- SQ4** Square Tube Class IV

MODEL / STYLE	YEAR	TRAILER HITCHES									
		PC	REC TYPE	REC SIZE	PART NO.	NO DRILL	FOOTNOTES	OPTIONAL DRAWBAR	WC (LBS.)	WD (LBS.)	IN
NISSAN (Continued)											
JUKE FWD, Except Nismo & Nismo RS	11-17	30	SQ1	1-1/4	24892		HM, JR	3593	200/2,000		25
Kicks	18	29	SQ1	1-1/4	24980		GP, JR, KH	3593	200/2,000		45
Kicks	19	29	SQ1	1-1/4	24980		GP, JR, KH	3593	200/2,000		45
Leaf	11-14										
Maxima Sedan	95-99	34	SQ1	1-1/4	24686		TA, GP	3593	200/2,000		30
Maxima Sedan	00-02	34	SQ1	1-1/4	24686		TA, GP	3592	200/2,000		30
Maxima Sedan	03	34	SQ1	1-1/4	24686		TA, GP	3592	200/2,000		30
Maxima	04-08	30	SQ1	1-1/4	24788	0	JR, TA, GP	3592	200/2,000		30
Maxima	09-14	15	SQ1	1-1/4	24796		AE, HM, TA	3594	200/2,000		45
Maxima	16-19	15	SQ1	1-1/4	24796		AE, HM, TA	3594	200/2,000		45
Murano	03-05	34	SQ3	2	75148	0	JR		350/3,500		30
Murano	06-07	34	SQ3	2	75148	0	JR		350/3,500		30
Murano Except w/Aero Kit & CrossCabriolet	09-14	30	SQ3	2	75647	0	GP, JR		400/4,000		35
Murano	15-19	28	RT3	2	75952	0	HM		600/4,000	600/4,000	15
NP300 Navara International Only	16-17	38	SQ4	2	76078	0	HM		800/8,000	800/8,000	30
NV1500	12-19	28	SQ4	2	75715	0	HM		1,125/7,500	1,000/10,000	20
NV200	13-17	31	RT3	2	75898	0	HM, JR, X		525/3,500		30
NV2500	12-19	28	SQ4	2	75715	0	HM		1,125/7,500	1,000/10,000	20
NV3500	12-19	28	SQ4	2	75715	0	HM		1,125/7,500	1,000/10,000	20
Pathfinder	96-04	39	SQ2	1-1/4	362221	0	HM	36071	300/3,500		20
Pathfinder		34	RT3	2	75077	0			500/5,000	550/5,500	20
Pathfinder	05-12										
Pathfinder	13-17	25	SQ4	2	76031	0	HM		900/6,000	900/6,000	25
Pathfinder	18-19	25	SQ4	2	76031	0	HM		900/6,000	900/6,000	25
Pathfinder Armada	04	38	RT4	2	75741	0	HM		600/6,000	1,000/10,000	15
Pathfinder Armada w/Factory 7-Way	04										
Pickup	95-97	41	SQ3	2	75186		GP		400/4,000	550/5,500	30
		50	SQ3	2	37136				500/5,000	600/6,000	30
Qashqai	17	26	SQ3	2	76177	0	GP, JR		525/3,500		45
Quest	93-97	41	SQ2	1-1/4	362611	0	JR, GP	36061	300/3,500		15
		42	SQ3	2	75089	0	JR		350/3,500	500/5,000	15
Quest	98	41	SQ2	1-1/4	362611	0	JR, GP	36061	300/3,500		15
		42	SQ3	2	75089	0	JR		350/3,500	500/5,000	15
Quest	99-02	34	SQ2	1-1/4	362771	0	JR, GP	36061	300/3,500		15
		41	SQ3	2	751021	0	JR		350/3,500	500/5,000	15
Quest	04-09	50	SQ3	2	75159	0	JR		350/3,500	500/5,000	20
Quest	11-16	51	RT3	2	75714	0	HM, JR		525/3,500		35
Quest	17										
Rogue Except Krom	08-13	18	SQ2	1-1/4	36542	0	GP, TW	36053	300/3,500		15
		23	SQ3	2	75902	0	GP, TW		350/3,500		15
Rogue Except Sport	14-19	18	SQ2	1-1/4	36542	0	GP, TW	36053	300/3,500		15
		23	SQ3	2	75902	0	GP, TW		350/3,500		15
Rogue Select	14	18	SQ2	1-1/4	36542	0	GP, TW	36053	300/3,500		15
		23	SQ3	2	75902	0	GP, TW		350/3,500		15
Rogue Sport	17-19	26	SQ3	2	76177	0	GP, JR		525/3,500		45
Sentra	00-02	31	SQ1	1-1/4	24750	0	TA, HM	3593	200/2,000		20
Sentra	03-06	31	SQ1	1-1/4	24750	0	TA, HM	3593	200/2,000		20
Sentra	07-12	22	SQ1	1-1/4	24794		TA, GP	3594	200/2,000		30
Sentra Except SR	13-19	28	SQ1	1-1/4	24907		HM	3593	200/2,000		35
Titan	04-15	38	RT4	2	41551	0			600/6,000	1,000/10,000	15
Titan w/Factory 7-Way	04-16										

AE Requires temporary removal of muffler during installation.
GP Hitch crossbar concealed behind bumper.
HM Hitch crossbar is visible beneath bumper.
JR Exhaust must be temporarily lowered for installation.

KH Minor heat shield modification may be required.
TA Trunk access required for hitch installation.
TW Receiver hitch may limit hands-free liftgate sensor range
X Minor fascia trimming required.

T-ONE						TOW HARNESS						4-FLAT WIRING				REQ. 4 FLAT WIRING		7-WAY HARDWIRE	BRAKE CONTROL HARNESS	IN	
PC	T-ONE	FN	IN	AMP	CP	PC	TOW HARN	FN	IN	AMP	CP	TYPE	ELEC	POS	CHOICE 1	CHOICE 2	6-WAY ADAPTER				7-WAY ADAPTER
NISSAN (Continued)																					
E17	118528	CH	45	2.1,5.6	X								B,E	SUV3,4	119191	119148	20320	20321			
E19	118794	CH,BN	45	5.7,5	X								B,E	SUV1,2	119191	119148					3050-P 5
E16	118625	CH	45	2.1,5.6	X								B,E	PC3,4	119191	119148					
													B	PC3,4	119130	119178					
													B	PC3,4	119130	119178					
													B,E	PC3,4	119191	119148					
E17	118470	CH	45	2.1,5.6	X								B,E	PC3,4	119191	119148					
E17	118470	CH	45	2.1,5.6	X								B,E	PC3,4	119191	119148					
E15	118676	CH	45	4.2,7.5	X								B,E	PC3,4	119191	119148					
													D			119251	20320	20321			
E17	118775	CH	45	5.7,5	X								N	SUV1,2		119251	20320	20321			
E15	118653	CH	45	4.2,7.5	X								B,E	SUV3,4	119191	119148	20320	20321	20224		
E15	118660	CH	45	4.2,7.5	X								B,E	SUV3,4	119191	119148	20320	20321	20224		
E17	118553	CH	45	4.2,7.5	X								B,E	SUV3,4	119191	119148	20320	20321	20224		
E17	118597	CH	45	4.2,7.5	X								B,E	SUV3,4	119191	119148	20320	20321	20224		
E17	118553	CH	45	4.2,7.5	X								B,E	SUV3,4	119191	119148	20320	20321	20224		
E17	118553	CH	45	4.2,7.5	X								B,E	SUV3,4	119191	119148	20320	20321	20224		
E10	118361	HG	20	2.1,5									B	SUV1,2	119130	119178	20320	20321	20224		
E3	118263	BN	5	7.5		E9	118267	BN,RD	30			7-Way	B	SUV5	119130	119178					3050-P 5
						E21	118266	BN,RD	30			7-Way									
E20	118670	BN	30	7.5		E23	118273	BN,RD	20	10		7-Way	B,E	SUV1,2	119191	119148					3050-P 5
E20	118670	BN	30	7.5		E23	118273	BN,RD	20	10		7-Way	B,E	SUV1,2	119191	119148					
						E8	118384	BN,RD	5	7.5		4-Flat	A	SUV6	119148	20252	20320	20321	20224	3050-P	5
							85219	RD	5			7-Way	H	SUV6	119148	20252					
E8	118353	BN,HG	10	2.1,5									B	PU1,2	119130	119178	20320	20321	20224		
													B	SUV1,2	119130	119178	20320	20321	20224		
E10	118362	BN,HG	5	2.1,5									B	SUV1,2	119130	119178	20320	20321	20224		
													B	SUV1,2	119130	119178	20320	20321	20224		
E16	118469	CH	45	2.1,5.6	X								B,E	SUV1,2	119191	119148	20320	20321	20224		
E19	118547	BN,CH	45	4.2,7.5	X								B,E	SUV1,2	119191	119148	20320	20321	20224		
E19	118547	BN,CH	45	4.2,7.5	X								B,E	SUV1,2	119191	119148	20320	20321	20224		
E15	118480	CH	45	2.1,5.6	X								B,E	SUV3,4	119191	119148	20320	20321	20224		
E15	118480	CH	45	2.1,5.6	X								B,E	SUV3,4	119191	119148	20320	20321	20224		
E15	118480	CH	45	2.1,5.6	X								B,E	SUV3,4	119191	119148	20320	20321	20224		
E15	118757	CH	45	5.7,5	X								B,E	SUV1,2	119191	119148	20320	20321	20224		
													B	PC3,4	119130	119178					
													B,E	PC3,4	119191	119148					
E17	118470	CH	45	2.1,5.6	X								B,E	PC3,4	119191	119148					
E16	118582	CH	45	2.1,5.6	X								B,E	PC3,4	119191	119148					
						E8	118384	BN,RD	5	7.5		4-Flat	A	PU3	119148	20252	20320	20321	20224	3050-P	5
							74682	RD	10			Both	H	PU3	119148	20252					3050-P 5
							85219	RD	5			7-Way									

A 2 wire system.
B 3 wire system. Converter required.
BN Exterior mounted plug on some or all models. May require an aftermarket electrical mounting box or bracket. (Sold separately)
CH T-One is equipped with circuit protected ModuLite® module.
D See auto dealer for trailer tow wiring kit.
E ModuLite® required.
H 3 wire system with OEM standard 2 wire harness.
HG T-One incorporates taillight converter.
N DO NOT cut or splice vehicle wiring. Only use approved T-One or see auto dealer for trailer tow wiring kit.
RD For vehicles equipped with factory tow package may require additional components or may be used as a replacement harness.

RT3 Round Tube Class III 2"
RT4 Round Tube Class IV 2"
SQ1 Square Tube Class I
SQ2 Square Tube Class II
SQ3 Square Tube Class III
SQ4 Square Tube Class IV

MODEL / STYLE	YEAR	TRAILER HITCHES									
		PC	REC TYPE	REC SIZE	PART NO.	NO DRILL	FOOTNOTES	OPTIONAL DRAWBAR	WC (LBS.)	WD (LBS.)	IN
NISSAN (Continued)											
Titan Except Titan XD or Models w/ Factory 7-Way Wiring	17	40	RT4	2	76154	0	HM		800/8,000	1,200/12,000	30
Titan w/ Factory 7-Way Wiring Except Titan XD	17	40	RT4	2	76154	0	HM		800/8,000	1,200/12,000	30
Versa 4 Dr. Sedan	07-11	35	SQ1	1-1/4	24798		HM	3593	200/2,000		25
Versa 5 Dr. Hatchback	07-12	35	SQ1	1-1/4	24798		HM	3593	200/2,000		25
Versa 4 Dr. Sedan	12-17	29	SQ1	1-1/4	24887		HM,JR,KH	3592	200/2,000		30
Versa 4 Dr. Sedan	18										
Versa Note	14-17	15	SQ1	1-1/4	24909		HM,JR,KH	3592	200/2,000		30
Versa Note	18										
Xterra	00-04	41	RT3	2	75107	0			350/3,500	550/5,500	15
Xterra	05-15										
Xterra		36	RT3	2	75291	0			350/3,500	550/5,500	30
Xterra w/Factory Tow Package	05-15										
X-Trail (Canada Only)	05-06	35	SQ1	1-1/4	24740	0	EP,GP	3593	200/2,000		45
OLDSMOBILE											
88	96-99	50	SQ2	1-1/4	36211f		GP,KH	36061	300/3,500		30
Alero	99-04	41	SQ2	1-1/4	36288		GP	36071	300/3,500		20
Aurora	01-03	39	SQ2	1-1/4	36309		HM,JR	36063	300/3,500		30
Bravada	96-97	32	SQ2	1-1/4	36244	0	GP	36051	300/3,500		15
Bravada		21	RT3	2	75079	0	SD		400/4,000	600/6,000	15
Bravada	98-01	32	SQ2	1-1/4	36244	0	FP,GP,KK	36051	300/3,500		15
Bravada		21	RT3	2	75079	0	FP,KK,SD		400/4,000	600/6,000	15
Bravada w/Factory 7-Way	99-04										
Bravada w/Factory 7-Way	02-04										
Cutlass 4 Dr., FWD	97-99	34	SQ1	1-1/4	24656	0	GP	3592	200/2,000		15
Cutlass 4 Dr., FWD		41	SQ2	1-1/4	36233		GP	36061	300/3,500		20
Cutlass Supreme 4 Dr. FWD	92-97	43	SQ2	1-1/4	36124f		AI,JR,TA,HM	36053	300/3,500		60
Intrigue	98-02	24	SQ1	1-1/4	24659		TA,GP	3592	200/2,000		30
Intrigue		37	SQ2	1-1/4	36374		GP,JR	36061	300/3,500		30
ISS	96-99	50	SQ2	1-1/4	36211f		GP,KH	36061	300/3,500		30
Regency	97-98	50	SQ2	1-1/4	36211f		GP,KH	36061	300/3,500		30
Silhouette	97-04	27	SQ1	1-1/4	24721f		AL,GP,JR	3592	200/2,000		30
Silhouette		27	SQ2	1-1/4	36361		AL,GP,JR	36061	300/3,500		40
Silhouette		22	SQ3	2	75278		AL,GP,JR		350/3,500	500/5,000	40
PLYMOUTH											
Breeze	96-00	40	SQ2	1-1/4	36301		JR,HM	36061	300/3,500		60
Grand Voyager	96-00	23	SQ2	1-1/4	36296	0	GP	36071	300/3,500		30
Grand Voyager		30	RT3	2	75119				350/3,500	500/5,000	30
Grand Voyager		50	SQ3	2	37136				500/5,000	600/6,000	40
Neon	00-01	42	SQ1	1-1/4	24701f		GP,JR	3593	200/2,000		20
Voyager	96-00	23	SQ2	1-1/4	36296	0	GP	36071	300/3,500		30
Voyager		30	RT3	2	75119				350/3,500	500/5,000	30
Voyager		50	SQ3	2	37136				500/5,000	600/6,000	40
PONTIAC											
Aztek	01-05	34	SQ2	1-1/4	36425		HM	36071	300/3,500		40
Aztek		32	SQ3	2	75138	0			350/3,500		55
Aztek		28	SQ3	2	75430		HM		350/3,500		40
Bonneville Except SLE/SSE/SSEi	96-99	50	SQ2	1-1/4	36211f		GP,KH	36063	300/3,500		30
Bonneville	00-05	39	SQ2	1-1/4	36309		HM,JR	36063	300/3,500		30
G3 5 Dr.	09	20	SQ1	1-1/4	24741		GP	3593	200/2,000		30
G3 Wave 5 Dr. (Canada Only)	09	20	SQ1	1-1/4	24741		GP	3593	200/2,000		30
G5 Except GT	07-09	20	SQ1	1-1/4	24745		JR,HM	3593	200/2,000		40

AI Additional installation time may be required.

AL Additional installation time required for vehicles equipped with load leveling compressor.

EP Fascia trimming may be required.

FP Spare tire repositioning and/or modification of spare tire carrier may be required.

GP Hitch cross-tube concealed behind bumper.

HM Hitch cross-tube is visible beneath bumper.

JR Exhaust must be temporarily lowered for installation.

KH Minor heat shield modification may be required.

KK When installing on a vehicle originally equipped with an OEM hitch, OEM bumper brackets must be purchased and installed prior to new hitch installation.

SD Hitches produced before 07/21/06 are rated at 350/3500 WC.

TA Trunk access required for hitch installation.

T-ONE					TOW HARNESS					4-FLAT WIRING				REQ. 4 FLAT WIRING		7-WAY HARDWARE	BRAKE CONTROL HARNESS	IN			
PC	T-ONE	FN	IN	AMP	CP	PC	TOW HARN	FN	IN	AMP	CP	TYPE	ELEC	POS	CHOICE 1				CHOICE 2	6-WAY ADAPTER	7-WAY ADAPTER
NISSAN (Continued)																					
													A	PU3	119148	20252	20320	20321	20224	3050-P	5
													H	PU3						3050-P	5
													B,E	PC3,4	119191	119148					
E17	118545	CH	45	2.1,5,6	X								B,E	PC3,4	119191	119148					
													B,E	PC3,4	119191	119148					
													B,E	PC3,4	119191	119148					
E16	118582	CH	45	2.1,5,6	X								B,E	PC3,4	119191	119148					
E16	118582	CH	45	2.1,5,6	X								B,E	PC3,4	119191	119148					
						E1	118244	BN,RD	5	7.5		4-Flat	B	SUV7	119130	119178	20320	20321	20224		
						E21	118266	BN,RD	30			7-Way	H	SUV5	119148	20252					
													B,E	SUV5	119191	119148					
													B	SUV1,2	119130	119178					
OLDSMOBILE																					
													A	PC3,4	119148	20252					
													B	PC3,4	119130	119178					
													B,E	PC3,4	119191	119148					
													A	SUV7	119148	20252	20320	20321	20224		
						E8	118384	BN,RD	5	7.5		4-Flat	A	SUV7	119148	20252	20320	20321	20224		
E8	118384	BN,RD	5	7.5			74682	RD	10		Both	A	SUV6	119148	20252						
							85219	RD	5		7-Way										
							8551511	RD			7-Way										
						E8	118384	BN,RD	5	7.5		4-Flat	H	SUV6	119148	20252					
													B	PC3,4	119130	119178					
													A	PC3,4	119148	20252					
													B	PC3,4	119130	119178					
													A	PC3,4	119148	20252					
E8	118355	HG	10	2.1,5									A	PC3,4	119148	20252					
													B	SUV3	119130	119178	20320	20321	20224		
PLYMOUTH																					
E11	118334	HG	20	2.1,5									B	PC3,4	119130	119178	20320	20321	20224		
													B	SUV1,2	119130	119178					
													A	PC3,4	119148	20252					
E11	118334	HG	20	2.1,5									B	SUV1,2	119130	119178	20320	20321	20224		
PONTIAC																					
E10	118383	BN	20	7.5									A	SUV1,2	119148	20252	20320	20321	20224		
													E	PC3,4	119191	119148					
													B,E	PC3,4	119191	119148					
E13	118485	CG	15	2.1,7,5	X								B	PC3,4	119130	119178					
													B	PC3,4	119130	119178					
E5	118407	BN	15	7.5									A	PC1,2	119148	20252					

- A** 2 wire system.
- B** 3 wire system. Converter required.
- BN** Exterior mounted plug on some or all models. May require an aftermarket electrical mounting box or bracket. (Sold separately)
- CG** T-One incorporates circuit protected taillight converter.
- CH** T-One is equipped with circuit protected ModuLite® module.
- E** ModuLite® required.
- H** 3 wire system with OEM standard 2 wire harness.
- HG** T-One incorporates taillight converter.
- RD** For vehicles equipped with factory tow package may require additional components or may be used as a replacement harness.
- Z** May be equipped with Factory Tow Prep Plug. Determine at time of installation.

- RT3** Round Tube Class III 2"
- RT4** Round Tube Class IV 2"
- SQ1** Square Tube Class I
- SQ2** Square Tube Class II
- SQ3** Square Tube Class III

PONTIAC

RECEIVER HITCHES

MODEL / STYLE	YEAR	TRAILER HITCHES									
		PC	REC TYPE	REC SIZE	PART NO.	NO DRILL	FOOTNOTES	OPTIONAL DRAWBAR	WC (LBS.)	WD (LBS.)	IN
PONTIAC (Continued)											
G5 GT	07-09	30	SQ1	1-1/4	24756		HM,JR	3594	200/2,000		25
G6	05-09	36	SQ2	1-1/4	36426		GP	36065	300/3,500		30
G8	08-09	31	SQ1	1-1/4	248211	0	JR,KH,HM	3594	200/2,000		45
Grand Am	99-05	41	SQ2	1-1/4	36288		GP	36071	300/3,500		20
Grand Prix	97-08	27	SQ1	1-1/4	24660	0	TA,GP	3594	200/2,000		20
		51	SQ2	1-1/4	36241		JR,GP	36065	300/3,500		35
Grand Prix SE Sedan	97-03	24	SQ1	1-1/4	24659		TA,GP	3592	200/2,000		30
Montana	99-05	27	SQ1	1-1/4	247211		AL,GP,JR	3592	200/2,000		30
		27	SQ2	1-1/4	36361		AL,GP,JR	36061	300/3,500		40
		22	SQ3	2	75278		AL,GP,JR		350/3,500	500/5,000	40
Montana SV6	05-06	27	SQ2	1-1/4	36361		AL,GP,JR	36061	300/3,500		40
		22	SQ3	2	75278		AL,GP,JR		350/3,500	500/5,000	40
Montana SV6 (Canada Only)	07-09	27	SQ2	1-1/4	36361		AL,GP,JR	36061	300/3,500		40
		22	SQ3	2	75278		AL,GP,JR		350/3,500	500/5,000	40
Pursuit 2 Dr. (Canada Only)	05-06	20	SQ1	1-1/4	24745		JR,HM	3593	200/2,000		40
Pursuit 4 Dr. (Canada Only)	05-06	20	SQ1	1-1/4	24745		JR,HM	3593	200/2,000		40
Solstice	06-08	21	SQ1	1-1/4	24833	0	HM,JR	3594	200/2,000		35
Solstice GXP	07-08	21	SQ1	1-1/4	24833	0	HM,JR,X	3594	200/2,000		35
Solstice	09	21	SQ1	1-1/4	24833		HM,JR	3594	200/2,000		40
Solstice GXP	09	21	SQ1	1-1/4	24833		HM,JR,X	3594	200/2,000		40
Sunfire Except GT	95-99	31	SQ1	1-1/4	24733		GP,JR	3592	200/2,000		40
Sunfire	00-02	36	SQ1	1-1/4	246131		JR,KH,GP	3592	200/2,000		40
Sunfire	03-05	31	SQ1	1-1/4	24733		GP,JR	3592	200/2,000		40
Sunfire GT	95-99	36	SQ1	1-1/4	246131		JR,KH,GP	3592	200/2,000		40
Torrent	06	18	SQ2	1-1/4	36408	0	HM	36051	300/3,500		25
		14	RT3	2	76028	0	HM		675/4,500	675/4,500	30
Torrent	07-09	18	SQ2	1-1/4	36408	0	HM	36051	300/3,500		25
		14	RT3	2	76028	0	HM		675/4,500	675/4,500	30
Trans Sport	97-98	27	SQ1	1-1/4	247211		AL,GP,JR	3592	200/2,000		30
		27	SQ2	1-1/4	36361		AL,GP,JR	36061	300/3,500		40
		22	SQ3	2	75278		AL,GP,JR		350/3,500	500/5,000	40
Vibe	03-08	15	SQ1	1-1/4	24812	0	HM	3593	200/2,000		15
Vibe Except GT	09-10	15	SQ1	1-1/4	24812	0	HM	3593	200/2,000		15
Wave 5 Dr. (Canada Only)	05-07	20	SQ1	1-1/4	24741		GP	3593	200/2,000		30
Wave5 (Canada Only)	05-07	20	SQ1	1-1/4	24741		GP	3593	200/2,000		30
PORSCHE											
Cayenne	11-18	45	SQ4	2	75950	0	GP,EP,TA		750/7,500		70
Macan	15-17	34	SQ3	2	75940	0	DU,EP,GP,TA		750/5,000		60
RAM											
1500	11-12	11	SQ4	2	75662		CP		600/6,000	1,000/10,000	20
		39	RT5	2	75232	0	CP		1,000/10,000	1,200/12,000	40
		39	SQ5	2	41948	0	@,HM,CP		1,500/12,000	1,500/15,000	30
1500 w/Factory 7-Way	11-17										
1500	13-14	11	SQ4	2	75662		CP		600/6,000	1,000/10,000	20
		39	RT5	2	75232	0	CP		1,000/10,000	1,200/12,000	40
		39	SQ5	2	41948	0	@,HM,CP		1,500/12,000	1,500/15,000	30
1500	15-18	11	SQ4	2	75662		CP		600/6,000	1,000/10,000	20
		39	RT5	2	75232	0	CP		1,000/10,000	1,200/12,000	40
		39	SQ5	2	41948	0	@,HM,CP		1,500/12,000	1,500/15,000	30
1500 (Classic)	19	11	SQ4	2	75662		CP		600/6,000	1,000/10,000	20
		39	RT5	2	75232	0	CP		1,000/10,000	1,200/12,000	40
		39	SQ5	2	41948	0	@,HM,CP		1,500/12,000	1,500/15,000	30

@ Ultra Frame ball mount must be used to achieve maximum weight carrying rating.

AL Additional installation time required for vehicles equipped with load leveling compressor.

CP Fits all models without factory installed receiver.

DU Fascia removal required.

EP Fascia trimming may be required.

GP Hitch cross-tube concealed behind bumper.

HM Hitch cross-tube is visible beneath bumper.

JR Exhaust must be temporarily lowered for installation.

KH Minor heat shield modification may be required.

TA Trunk access required for hitch installation.

X Minor fascia trimming required.

T-ONE					TOW HARNESS					4-FLAT WIRING				REQ. 4 FLAT WIRING		7-WAY HARDWIRE	BRAKE CONTROL HARNESS	IN			
PC	T-ONE	FN	IN	AMP	CP	PC	TOW HARN	FN	IN	AMP	CP	TYPE	ELEC	POS	CHOICE 1				CHOICE 2	6-WAY ADAPTER	7-WAY ADAPTER
PONTIAC (Continued)																					
E5	118407	BN	15	7.5									A	PC1,2	119148	20252					
E7	118439	BN	15	7.5									A	PC3,4	119148	20252					
													B	PC3,4	119130	119178					
													B	PC3,4	119130	119178					
													A	PC3,4	119148	20252					
													A	PC3,4	119148	20252					
E8	118355	HG	10	2.1,5									B	SUV3	119130	119178	20320	20321	20224		
E10	118396	BN	15	7.5									A	SUV1,2	119148	20252	20320	20321	20224		
E10	118396	BN	15	7.5									A	SUV1,2	119148	20252	20320	20321	20224		
E5	118407	BN	15	7.5									A	PC1,2	119148	20252					
E8	118398	BN	10	7.5									A	PC1,2	119148	20252					
													A	PC1,2	119148	20252					
													A	PC1,2	119148	20252					
													A	PC1,2	119148	20252					
													A	PC1,2	119148	20252					
													A	PC3,4	119148	20252					
													A	PC3,4	119148	20252					
													A	PC3,4	119148	20252					
E8	118391	CG	10	2.1,5	X								B	SUV3	119130	119178	20320	20321	20224		
E7	118432	CE	10	7.5									B	SUV1,2	119130	119178	20320	20321	20224		
E8	118355	HG	10	2.1,5									B	SUV3	119130	119178	20320	20321	20224		
E11	118458	CG	15	2.1,5	X								B	SUV3,4	119130	119178					
E16	118460	CH	45	2.1,4,2	X								B,E	SUV3,4	119191	119148	20320	20321			
													B	PC3,4	119130	119178					
													B	PC3,4	119130	119178					
PORSCHE																					
													B,E	SUV1,2	119191	119148	20320	20321	20224		
													BT	SUV1,2	119251	119191	20320	20321	20224		
RAM																					
						E8	118384	BN,RD	5	7.5		4-Flat	A	PU3	119148	20252	20320	20321	20224	3021-P	5
E8	118384	BN,RD	5	7.5			74682 85219	RD RD	10 5			Both 7-Way	A	PU3	119148	20252					
						E8	118384	BN,RD	5	7.5		4-Flat	A	PU3	119148	20252	20320	20321	20224	3023-P	10
						E8	118384	BN,RD	5	7.5		4-Flat	A	PU3	119148	20252	20320	20321	20224	3024-P	5
						E8	118384	BN,RD	5	7.5		4-Flat	A	PU3	119148	20252	20320	20321	20224	3024-P	5

A 2 wire system.
B 3 wire system. Converter required.
BN Exterior mounted plug on some or all models. May require an aftermarket electrical mounting box or bracket. (Sold separately)
BT Shared Brake/Tail multiplexed wiring system. ModuLite® HD Plus or Ultra required.
CE T-One includes fuse(s) & relay(s). Converter not required. Standard 2 wire system at factory tow plug.
CG T-One incorporates circuit protected taillight converter.
CH T-One is equipped with circuit protected ModuLite® module.
E ModuLite® required.
HG T-One incorporates taillight converter.
RD For vehicles equipped with factory tow package may require additional components or may be used as a replacement harness.

RT3 Round Tube Class III 2"
RT5 Round Tube Class V 2"
SQ1 Square Tube Class I
SQ2 Square Tube Class II
SQ3 Square Tube Class III
SQ4 Square Tube Class IV
SQ5 Square Tube Class V

RAM

RECEIVER HITCHES

MODEL / STYLE	YEAR	TRAILER HITCHES									
		PC	REC TYPE	REC SIZE	PART NO.	NO DRILL	FOOTNOTES	OPTIONAL DRAWBAR	WC (LBS.)	WD (LBS.)	IN
RAM (Continued)											
1500 (New Body Style)	19	59	SQ5	2	41913	0	@,AA,EF,J,LT		1,700/15,000	1,700/17,000	60
2500	11-12	37	SQ5	2	41929		@,GP,KL,SG		1,200/12,000	1,500/15,000	35
		66	SQ5	2-1/2	45509		#,AA,GH,HM,LT,SO,TO		2,000/18,000	2,500/18,000	95
2500 Except Mega Cab	11-12	63	SQ5	2-1/2	45518		#,KL,SB		1,200/12,000	1,700/14,000	35
2500 w/Factory 7-Way	11-17										
2500	13-14	37	SQ5	2	41929		@,GP,KL,SG		1,200/12,000	1,500/15,000	35
		66	SQ5	2-1/2	45509		#,AA,GH,HM,LT,SO,TO		2,000/18,000	2,500/18,000	95
2500 Except Mega Cab	13-14	63	SQ5	2-1/2	45518		#,KL,SB		1,200/12,000	1,700/14,000	35
2500	15-18	37	SQ5	2	41929		@,GP,KL,SG		1,200/12,000	1,500/15,000	35
		66	SQ5	2-1/2	45509		#,AA,GH,HM,LT,SO,TO		2,000/18,000	2,500/18,000	95
2500 Except Mega Cab	15-18	63	SQ5	2-1/2	45518		#,KL,SB		1,200/12,000	1,700/14,000	35
2500	19-18										
3500	11-12	37	SQ5	2	41929		@,GP,KL,SG		1,200/12,000	1,500/15,000	35
		66	SQ5	2-1/2	45509		#,AA,GH,HM,LT,SO,TO		2,000/18,000	2,500/18,000	95
3500 Cab & Chassis, w/34" Wide Frames	11-12	29	SQ5	2	41936		@		1,200/12,000		30
		55	SQ5	2	41947		@		1,600/15,000	1,600/16,000	35
3500 Except Mega Cab	11-12	63	SQ5	2-1/2	45518		#,KL,SB		1,200/12,000	1,700/14,000	35
3500 w/Factory 7-Way	11-17										
3500	13-14	37	SQ5	2	41929		@,GP,KL,SG		1,200/12,000	1,500/15,000	35
		66	SQ5	2-1/2	45509		#,AA,GH,HM,LT,SO,TO		2,000/18,000	2,500/18,000	95
3500 Except Mega Cab	13-14	63	SQ5	2-1/2	45518		#,KL,SB		1,200/12,000	1,700/14,000	35
3500	15-18	37	SQ5	2	41929		@,GP,KL,SG		1,200/12,000	1,500/15,000	35
		66	SQ5	2-1/2	45509		#,AA,GH,HM,LT,SO,TO		2,000/18,000	2,500/18,000	95
3500 Except Mega Cab	15-18	63	SQ5	2-1/2	45518		#,KL,SB		1,200/12,000	1,700/14,000	35
3500	19-18										
4500 Cab & Chassis, w/34" Wide Frames	11-12	29	SQ5	2	41936		@		1,200/12,000		30
		55	SQ5	2	41947		@		1,600/15,000	1,600/16,000	35
4500 Cab & Chassis, w/34" Wide Frames	13-17	38	SQ5	2	41952		@		1,500/15,000	1,600/16,000	45
5500 Cab & Chassis, w/34" Wide Frames	11-12	29	SQ5	2	41936		@		1,200/12,000		30
		55	SQ5	2	41947		@		1,600/15,000	1,600/16,000	35
5500 Cab & Chassis, w/34" Wide Frames	13-17	38	SQ5	2	41952		@		1,500/15,000	1,600/16,000	45
C/V Tradesman	12-15	24	SQ2	1-1/4	36455	0	GP,JR	36061	300/3,500		20
		19	SQ3	2	75579	0	GP,JR		400/4,000	500/5,000	20
Dakota	11	27	SQ3	2	75251		HM		500/5,000	800/8,000	20
ProMaster 1500 All Models	14-19	25	SQ3	2	76050	0	AA,DU,GP		500/5,000		45
ProMaster 1500 Except w/Extended Body	14-19	56	RT4	2	75882		HM		750/6,000	750/7,500	45
ProMaster 2500 All Models	14-19	25	SQ3	2	76050	0	AA,DU,GP		500/5,000		45
ProMaster 2500 Except w/Extended Body	14-19	56	RT4	2	75882		HM		750/6,000	750/7,500	45
ProMaster 3500 All Models	14-19	25	SQ3	2	76050	0	AA,DU,GP		500/5,000		45
ProMaster 3500 Except w/Extended Body	14-19	56	RT4	2	75882		HM		750/6,000	750/7,500	45
ProMaster City	15-17	37	SQ3	2	75219	0	GP		350/3,500		60
ProMaster City	18-19										
SAAB											
9-3	99-02	34	SQ2	1-1/4	36280		JR,GP	36053	300/3,500		30
9-3 Convertible	03	34	SQ2	1-1/4	36280		JR,GP	36053	300/3,500		30
9-5	99-05	41	SQ2	1-1/4	36286	0	TA,HM	36051	300/3,500		30
9-7X w/Factory 7-Way	05-09										

Titan hitches require use of a 2-1/2" shank Titan ball mount.
 @ Ultra Frame ball mount must be used to achieve maximum weight carrying rating.
 AA Requires temporary removal of bumper during installation.
 DU Fascia removal required.
 EF Fits all models with standard bumpers.
 GH Will not fit models with 34 in. wide frames.
 GP Hitch cross-tube concealed behind bumper.
 HM Hitch cross-tube is visible beneath bumper.
 J Under vehicle spare tire stowage is retained.

JR Exhaust must be temporarily lowered for installation.
 KL Hitch is designed to attach beneath the OEM hitch.
 LT Requires removal of factory hitch if equipped.
 SB Will not fit models with short bed.
 SG Hitches produced before 09/10/07 are rated at 1000/10000 WC & 1200/12000 WD.
 SO With this hitch installed the step bumper is no longer able to be used as a towing point.
 TA Trunk access required for hitch installation.
 TO Will not fit models equipped Chassis Cab spring mount.

T-ONE					TOW HARNESS					4-FLAT WIRING				REQ. 4 FLAT WIRING		7-WAY HARDWARE	BRAKE CONTROL HARNESS	IN			
PC	T-ONE	FN	IN	AMP	CP	PC	TOW HARN	FN	IN	AMP	CP	TYPE	ELEC	POS	CHOICE 1				CHOICE 2	6-WAY ADAPTER	7-WAY ADAPTER
RAM (Continued)																					
						E8	118384	BN,RD	5	7.5		4-Flat	A	PU3	119148	20252	20320	20321	20224	3024-P	5
						E8	118384	BN,RD	5	7.5		4-Flat	A	PU3	119148	20252	20320	20321	20224	3021-P	5
E8	118384	BN,RD	5	7.5			74682	RD	10			Both	A	PU3	119148	20252					
							85219	RD	5			7-Way									
						E8	118384	BN,RD	5	7.5		4-Flat	A	PU3	119148	20252	20320	20321	20224	3023-P	10
						E8	118384	BN,RD	5	7.5		4-Flat	A	PU3	119148	20252	20320	20321	20224	3023-P	10
						E8	118384	BN,RD	5	7.5		4-Flat	A	PU3	119148	20252	20320	20321	20224	3024-P	5
						E8	118384	BN,RD	5	7.5		4-Flat	A	PU3	119148	20252	20320	20321	20224	3024-P	5
						E8	118384	BN,RD	5	7.5		4-Flat	A	PU3	119148	20252	20320	20321	20224	3021-P	5
													C	PU1,2	119191	119148	20320	20321	20224		
						E8	118384	BN,RD	5	7.5		4-Flat	A	PU3	119148	20252	20320	20321	20224	3021-P	5
E8	118384	BN,RD	5	7.5			74682	RD	10			Both	A	PU3	119148	20252					
							85219	RD	5			7-Way									
						E8	118384	BN,RD	5	7.5		4-Flat	A	PU3	119148	20252	20320	20321	20224	3023-P	10
						E8	118384	BN,RD	5	7.5		4-Flat	A	PU3	119148	20252	20320	20321	20224	3023-P	10
						E8	118384	BN,RD	5	7.5		4-Flat	A	PU3	119148	20252	20320	20321	20224	3024-P	5
						E8	118384	BN,RD	5	7.5		4-Flat	A	PU3	119148	20252	20320	20321	20224	3024-P	5
													A	PU3	119191	119148	20320	20321	20224		
													A	PU3	119191	119148	20320	20321	20224		
													A	PU3	119191	119148	20320	20321	20224		
E18	118534	BN,CH	45	4.2,7.5	X		22121			90		7-Way	C,E	SUV1.2	119191	119148	20320	20321	20224		
E7	118323	BN,HJ	10	7.5									A	PU1,2	119148	20252	20320	20321	20224	3020-P	5
E18	118618	CH	45	4.2,7.5	X		22112	BN	60			7-Way	B,E	SUV3,4	119191	119148	20320	20321	20224		
E18	118618	CH	45	4.2,7.5	X		22112	BN	60			7-Way	B,E	SUV3,4	119191	119148	20320	20321	20224		
E18	118618	CH	45	4.2,7.5	X		22112	BN	60			7-Way	B,E	SUV3,4	119191	119148	20320	20321	20224		
E18	118618	CH	45	4.2,7.5	X		22112	BN	60			7-Way	B,E	SUV3,4	119191	119148	20320	20321	20224		
E18	118618	CH	45	4.2,7.5	X		22112	BN	60			7-Way	B,E	SUV3,4	119191	119148	20320	20321	20224		
E18	118719	CH,BN	45	4.2,7.5	X								BT	SUV1.2	119192	119191					
E18	118719	CH,BN	45	4.2,7.5	X								BT	SUV1.2	119192	119191					
SAAB																					
													B,E	PC1,2	119191	119148					
													B,E	PC1,2	119191	119148					
													B,E	PC1,2	119191	119148					
						E8	118384	BN,RD	5	7.5		4-Flat	H	SUV6	119148	20252					
							74682	RD	10			Both									
							8551511	RD				7-Way									
							85219	RD	5			7-Way									

- A** 2 wire system.
- B** 3 wire system. Converter required.
- BN** Exterior mounted plug on some or all models. May require an aftermarket electrical mounting box or bracket. (Sold separately)
- BT** Shared Brake/Tail multiplexed wiring system. ModuLite® HD Plus or Ultra required.
- C** 2 or 3 wire system determine at installation.
- CH** T-One is equipped with circuit protected ModuLite® module.
- E** ModuLite® required.
- H** 3 wire system with OEM standard 2 wire harness.
- HJ** Per Dodge owner's manual: If trailer is equipped with more than standard lighting (1 taillight per side) use of ModuLite® or dealer supplied harness is required.
- RD** For vehicles equipped with factory tow package may require additional components or may be used as a replacement harness.

- RT4** Round Tube Class IV 2"
- SQ2** Square Tube Class II
- SQ3** Square Tube Class III
- SQ5** Square Tube Class V

MODEL / STYLE	YEAR	TRAILER HITCHES									
		PC	REC TYPE	REC SIZE	PART NO.	NO DRILL	FOOTNOTES	OPTIONAL DRAWBAR	WC (LBS.)	WD (LBS.)	IN
SATURN											
Astra Hatchback	08-09	34	SQ1	1-1/4	24809†	0	GP, JR	3594	200/2,000		25
Aura	07-09	24	SQ2	1-1/4	36479		GP, JR, RB	36065	300/3,500		45
Ion Except Redline & w/2.4 Liter Engine	03-07	31	SQ1	1-1/4	24734		JR, GP	3593	200/2,000		35
Ion 3 w/2.4 Liter Engine	05-07	30	SQ1	1-1/4	24756		HM, JR	3594	200/2,000		25
Ion Red Line	04-06	30	SQ1	1-1/4	24756		HM, JR	3594	200/2,000		25
L100	01-02	14	SQ1	1-1/4	24685†		TA, GP	3590	200/2,000		35
L200	01-02	14	SQ1	1-1/4	24685†		TA, GP	3590	200/2,000		35
L300	01-02	14	SQ1	1-1/4	24685†		TA, GP	3590	200/2,000		35
LS	00	14	SQ1	1-1/4	24685†		TA, GP	3590	200/2,000		35
LS1	00	14	SQ1	1-1/4	24685†		TA, GP	3590	200/2,000		35
LS2	00	14	SQ1	1-1/4	24685†		TA, GP	3590	200/2,000		35
LW200 Wagon	03	14	SQ1	1-1/4	24685†		TA, GP	3590	200/2,000		35
LW300 Wagon	03	14	SQ1	1-1/4	24685†		TA, GP	3590	200/2,000		35
Outlook	07-09	19	RT3	2	75528	0	GP, JR, TN		750/5,000	750/7,500	25
Outlook w/Factory 7-Way	07-09										
Relay	05-07	27	SQ2	1-1/4	36361		AL, GP, JR	36061	300/3,500		40
		22	SQ3	2	75278		AL, GP, JR		350/3,500	500/5,000	40
SC1 2 Dr. Coupe	96-02	33	SQ1	1-1/4	24620		HM, JR, KH, TA	3592	200/2,000		40
SC2 2 Dr. Coupe	96-02	33	SQ1	1-1/4	24620		HM, JR, KH, TA	3592	200/2,000		40
Sky	07-09	21	SQ1	1-1/4	24833	0	HM, JR	3594	200/2,000		35
SL 4 Dr. Sedan	91-02	33	SQ1	1-1/4	24620		HM, JR, KH, TA	3592	200/2,000		40
SL1 4 Dr. Sedan	91-02	33	SQ1	1-1/4	24620		HM, JR, KH, TA	3592	200/2,000		40
SL2 4 Dr. Sedan	91-02	33	SQ1	1-1/4	24620		HM, JR, KH, TA	3592	200/2,000		40
SW1 Wagon	93-99	33	SQ1	1-1/4	24620		HM, JR, KH, TA	3592	200/2,000		40
SW2 Wagon	93-01	33	SQ1	1-1/4	24620		HM, JR, KH, TA	3592	200/2,000		40
Vue Except Redline	02-07	18	SQ2	1-1/4	36408	0	HM	36051	300/3,500		25
		14	RT3	2	76028	0	HM		675/4,500	675/4,500	30
Vue	08-09	25	SQ2	1-1/4	36450	0	GP	36061	300/3,500		15
		30	SQ3	2	75556	0	GP		400/4,000	400/4,000	15
SCION											
FR-S	13-16	30	SQ1	1-1/4	24935	0	GP	3593	200/2,000		75
iA	16	32	RT1	1-1/4	24948	0	HM	3593	200/2,000		30
iM	16	20	SQ1	1-1/4	24952	0	GP, JR, SV	3593	200/2,000		40
tC	05-06	11	SQ1	1-1/4	24827		GP	3593	200/2,000		30
tC	07-10	11	SQ1	1-1/4	24827		GP	3593	200/2,000		30
tC Except Release Series	11-13	13	SQ1	1-1/4	24815	0	GP	3593	200/2,000		15
tC Except Dual Exhaust	14-16	13	SQ1	1-1/4	24921	0	GP	3592	200/2,000		15
xB	04-06	22	SQ1	1-1/4	28501	0	JR, GP	28451	200/2,000		25
xB Except Release Series	08-10	13	SQ1	1-1/4	24815	0	GP	3593	200/2,000		15
xB Except Release Series	11-13	13	SQ1	1-1/4	24815	0	GP	3593	200/2,000		15
xD	08-10	14	SQ1	1-1/4	24828	0	GP, JR	3593	200/2,000		20
STERLING TRUCK											
Bullet 45 w/34" Wide Frames	08-09	29	SQ5	2	41936		@		1,200/12,000		30
		55	SQ5	2	41947		@		1,600/15,000	1,600/16,000	35
Bullet 55 w/34" Wide Frames	08-09	29	SQ5	2	41936		@		1,200/12,000		30
		55	SQ5	2	41947		@		1,600/15,000	1,600/16,000	35
SUBARU											
Ascent	19	35	SQ3	2	76253	0	DU, J, TZ		750/5,000		60
B9 Tribeca	06-07	33	SQ3	2	75401	0	GP, JR		350/3,500	400/4,000	35
Baja	03-06	39	SQ1	1-1/4	24735†	0	HM	3590	200/2,000		20
BRZ	13-19	30	SQ1	1-1/4	24935	0	GP	3593	200/2,000		75

@ Ultra Frame ball mount must be used to achieve maximum weight carrying rating.

AL Additional installation time required for vehicles equipped with load leveling compressor.

DU Fascia removal required.

GP Hitch cross-tube concealed behind bumper.

HM Hitch cross-tube is visible beneath bumper.

J Under vehicle spare tire stowage is retained.

JR Exhaust must be temporarily lowered for installation.

KH Minor heat shield modification may be required.

RB Hitch installation can be made easier with a cutter type drill bit.

SV Trimming or removal of under body appearance panel may be required.

TA Trunk access required for hitch installation.

TN Hitches produced before 07/09/12 are rated at 500/5000 WC & 500/5000 WD.

TZ Requires replacement of the impact structure with hitch.

T-ONE					TOW HARNESS					4-FLAT WIRING				REQ. 4 FLAT WIRING		7-WAY HARDWARE	BRAKE CONTROL HARNESS	IN				
PC	T-ONE	FN	IN	AMP	CP	PC	TOW HARN	FN	IN	AMP	CP	TYPE	ELEC	POS	CHOICE 1				CHOICE 2	6-WAY ADAPTER	7-WAY ADAPTER	
SATURN																						
E12	118423	BN,HG	15	2.1,4.2									A,E	PC1,2	119191	119148						
													B,E	PC1,2	119191	119148						
													B	PC3,4	119130	119178						
													B	PC3,4	119130	119178						
													B	PC3,4	119130	119178						
													B	PC3,4	119130	119178						
													B	PC3,4	119130	119178						
													B	PC3,4	119130	119178						
													B	PC3,4	119130	119178						
													B	PC3,4	119130	119178						
													B	PC3,4	119130	119178						
													B	PC3,4	119130	119178						
													B	PC3,4	119130	119178						
E10	118434	BN	15	7.5		E8	118384	BN,RD	5	7.5		4-Flat	N	SUV1,2		119251	20320	20321		3026-P	5	
							74682	RD	10			Both	N	SUV6		119251						
							8551511	RD				7-Way										
							85219	RD	5			7-Way										
E10	118396	BN	15	7.5									A	SUV1,2	119148	20252	20320	20321	20224			
													B	PC3,4	119130	119178						
													B	PC3,4	119130	119178						
													A	PC1,2	119148	20252						
													B	PC3,4	119130	119178						
													B	PC3,4	119130	119178						
													B	PC3,4	119130	119178						
													B	PC3,4	119130	119178						
E16	118418	BN,CG	20	2.1,5	X								B	SUV1,2	119130	119178	20320	20321	20224			
E19	118443	CH	45	2.1,4.2	X								B,E	SUV3,4	119191	119148	20320	20321	20224			
SCION																						
E16	118629	CH	45	2.1,5.6	X								B,E	PC3,4	119191	119148						
E15	118728	CH,BN	45	5.7,5	X								B,E	PC1,2	119191	119148						
E16	118729	BN,CH	45	5.7,5	X								B,E	PC3,4								
													B	PC1,2	119130	119178						
E13	118484	CG	15	2.1,5	X								B	PC1,2	119130	119178						
													B	PC1,2	119130	119178						
E18	118615	CH	45	2.1,5.6	X								B,E	PC3,4	119191	119148						
E12	118414	CG	20	2.1,5	X								B	SUV3,4	119130	119178						
E18	118468	CH	45	2.1,5.6	X								B,E	SUV3,4	119191	119148	20320	20321				
E16	118460	CH	45	2.1,4.2	X								B,E	SUV3,4	119191	119148	20320	20321				
													B	PC3,4	119130	119178						
STERLING TRUCK																						
													C	PU1,2	119191	119148	20320	20321	20224			
													C	PU1,2	119191	119148	20320	20321	20224			
SUBARU																						
E10	118790	CH		5.7,5		E30	118290	CH,BN	45	4.2,12	X	7-Way	B,E	SUV3							3062-P	10
E12	118461	CH	10	2.1,4.2	X								B,E	SUV8	119191	119148	20320	20321	20224			
													B,E	SUV1,2	119191	119148						
E16	118629	CH	45	2.1,5.6	X								B,E	PC3,4	119191	119148						

A 2 wire system.
B 3 wire system. Converter required.
BN Exterior mounted plug on some or all models. May require an aftermarket electrical mounting box or bracket. (Sold separately)
C 2 or 3 wire system determine at installation.
CG T-One incorporates circuit protected taillight converter.
CH T-One is equipped with circuit protected ModuLite® module.
E ModuLite® required.
HG T-One incorporates taillight converter.
N DO NOT cut or splice vehicle wiring. Only use approved T-One or see auto dealer for trailer tow wiring kit.
RD For vehicles equipped with factory tow package may require additional components or may be used as a replacement harness.

RT1 Round Tube Class I 1-1/4"
RT3 Round Tube Class III 2"
SQ1 Square Tube Class I
SQ2 Square Tube Class II
SQ3 Square Tube Class III
SQ5 Square Tube Class V

SUBARU

RECEIVER HITCHES

MODEL / STYLE	YEAR	TRAILER HITCHES									
		PC	REC TYPE	REC SIZE	PART NO.	NO DRILL	FOOTNOTES	OPTIONAL DRAWBAR	WC (LBS.)	WD (LBS.)	IN
SUBARU (Continued)											
Crosstrek Except Hybrid	16-17	24	RT3	2	76084	0	HM,JR,KH		525/3,500		20
Crosstrek Hybrid	16-17	24	RT3	2	76084	0	HM,JR,KH		525/3,500		20
Crosstrek Except Hybrid	18-19	22	RT2	1-1/4	36644	0	JR,HM		350/3,500		60
		26	RT3	2	76209	0	JR,HM		675/4,500		60
Crosstrek Hybrid	18-19	22	RT2	1-1/4	36644	0	JR,HM		350/3,500		60
		26	RT3	2	76209	0	JR,HM		675/4,500		60
Crosstrek Except Hybrid	19					0	JR,HM				60
Forester	98-08	20	SQ2	1-1/4	36311	0	GP,JR	36051	300/3,500		30
Forester	09-13	28	SQ1	1-1/4	24807		HM,JR	3594	200/2,000		35
		27	RT2	1-1/4	36521		HM,JR	36061	300/3,500		35
		27	SQ3	2	75650		HM,JR,TQ		600/4,000		35
Forester	14-18	21	SQ2	1-1/4	36523		HM,JR,KH	36053	300/3,500		30
		21	RT3	2	75876	0	HM,JR,KH		525/3,500	525/4,000	25
		34	SQ3	2	76182	0	DU,FE,GP,JR		525/3,500		60
Forester	19	21	SQ2	1-1/4	36671	0		36071	350/3,500		30
		21	RT3	2	76271	0	JR,KH		525/3,500	525/3,500	30
Impreza	93-01	25	SQ1	1-1/4	24710	0	JR,GP	3593	200/2,000		30
Impreza Except WRX STi	02-07	25	SQ1	1-1/4	24710	0	JR,GP	3593	200/2,000		30
Impreza 4 Dr. Sedan	08-11	28	SQ1	1-1/4	24807		HM,JR	3594	200/2,000		35
Impreza 5 Dr. Wagon, Except WRX STi & w/Quad Exhaust Outlets	08-11	19	SQ1	1-1/4	248861		HM,JR	3593	200/2,000		45
		19	RT1	1-1/4	24959		HM,JR	3593	200/2,000		45
Impreza 4 Dr. Sedan, Except WRX & WRX STi	12-16	25	SQ1	1-1/4	248881		HM,JR	3594	200/2,000		30
		25	SQ1	1-1/4	24960	0	HM,JR,KH	3594	200/2,000		40
Impreza 5 Dr. Wagon, Except WRX STi & w/Quad Exhaust Outlets	12-16	19	SQ1	1-1/4	248861		HM,JR	3593	200/2,000		45
		19	RT1	1-1/4	24959		HM,JR	3593	200/2,000		20
Impreza 4 Dr. Sedan, Except WRX & WRX STi	17-19	25	SQ1	1-1/4	24960	0	HM,JR,KH	3594	200/2,000		40
Impreza 5 Dr. Wagon, Except WRX STi & w/Quad Exhaust Outlets	17-19	19	RT1	1-1/4	24959		HM,JR	3593	200/2,000		20
Impreza 5 Dr. Wagon, Except WRX STi & w/Quad Exhaust Outlets	18-19	22	RT2	1-1/4	36644		HM,JR		350/3,500		60
		26	RT3	2	76209	0	HM,JR		675/4,500		60
Legacy Coupe & Sedan	90-99	48	SQ2	1-1/4	36234		KH,HM	36071	300/3,500		25
Legacy Wagon, Except Outback	96-99	48	SQ2	1-1/4	36234		KH,HM	36061	300/3,500		20
Legacy Wagon, Outback	96-99	48	SQ2	1-1/4	36234		KH,HM	36061	300/3,500		20
Legacy Sedan, Except Outback	00-04	46	SQ2	1-1/4	36284	0	HM	36061	300/3,500		20
Legacy Wagon, Except Outback	00-04	46	SQ2	1-1/4	36284	0	HM	36061	300/3,500		20
Legacy Sedan, Except Outback	05-07	35	SQ2	1-1/4	36334	0	JR,HM	36071	300/3,500		25
		40	SQ3	2	75560	0	JR		400/4,000		25
Legacy Wagon, Except Outback	05-07	35	SQ2	1-1/4	36334	0	JR,HM	36053	300/3,500		25
		40	SQ3	2	75560	0	JR		400/4,000		25
Legacy Sedan	08-09	35	SQ2	1-1/4	36334	0	JR,HM	36071	300/3,500		25
		40	SQ3	2	75560	0	JR		400/4,000		25
Legacy Sedan	10-14	25	SQ2	1-1/4	36493		HM,JR,KH	36071	300/3,500		45
		30	SQ3	2	75673		HM,JR,KH,TI		600/4,000		45
Legacy Sedan	15-19	25	SQ2	1-1/4	36493		HM,JR,KH	36071	300/3,500		45
		30	SQ3	2	75673		HM,JR,KH,TI		600/4,000		45
Outback Sedan, Except Sport	00-04	46	SQ2	1-1/4	36284	0	HM	36053	300/3,500		20
Outback Wagon, Except Sport	00-04	46	SQ2	1-1/4	36284	0	HM	36053	300/3,500		20
Outback Sedan, Except Sport	05-07	35	SQ2	1-1/4	36334	0	JR,HM	36071	300/3,500		25
		40	SQ3	2	75560	0	JR		400/4,000		25
Outback Wagon, Except Sport	05-09	35	SQ2	1-1/4	36334	0	JR,HM	36053	300/3,500		25
		40	SQ3	2	75560	0	JR		400/4,000		25
Outback Wagon, Except Sport	10-19	25	SQ2	1-1/4	36493		HM,JR,KH	36051	300/3,500		45
		30	SQ3	2	75673		HM,JR,KH,TI		600/4,000		45
		35	SQ3	2	76227	0	AA,AI,DU,FE,X		600/4,000		45

AA Requires temporary removal of bumper during installation.

AI Additional installation time may be required.

DU Fascia removal required.

FE Fascia trimming may be required. Allow additional installation time.

GP Hitch cross-tube concealed behind bumper.

HM Hitch cross-tube is visible beneath bumper.

JR Exhaust must be temporarily lowered for installation.

KH Minor heat shield modification may be required.

TI Hitches produced before 06/06/11 are rated at 400/4000 WC.

TQ Hitches produced before 07/30/12 are rated at 350/3500 WC.

X Minor fascia trimming required.

T-ONE						TOW HARNESS						4-FLAT WIRING				REQ. 4 FLAT WIRING		7-WAY HARDWARE	BRAKE CONTROL HARNESS	IN
PC	T-ONE	FN	IN	AMP	CP	PC	TOW HARN	FN	IN	AMP	CP	TYPE	ELEC	POS	CHOICE 1	CHOICE 2	6-WAY ADAPTER			
SUBARU (Continued)																				
E11	118467	CH	15	2.1,5.6	X								B,E	SUV1,2	119191	119148	20320	20321		
E11	118467	CH	15	2.1,5.6	X								B,E	SUV1,2	119191	119148	20320	20321		
													B,E	SUV1,2	119191	119148	20320	20321		
E11	118467	CH	15	2.1,5.6	X								B,E	SUV1,2	119191	119148	20320	20321		
E12	118461	CH	10	2.1,4.2	X								B,E	SUV4	119191	119148				
E11	118467	CH	15	2.1,5.6	X								B,E	SUV8	119191	119148	20320	20321	20224	
E11	118467	CH	15	2.1,5.6	X								B,E	SUV8	119191	119148	20320	20321	20224	
													B,E	PC1,2	119191	119148				
													B,E	PC1,2	119191	119148				
E17	118464	CH	45	2.1,5.6	X								B,E	PC3,4	119191	119148				
													B,E	PC3,4	119191	119148				
E15	118581	CH	45	2.1,5.6	X								B,E	PC3,4	119191	119148				
E19	118573	CH	45	2.1,5.6	X								B,E	PC3,4	119191	119148				
E16	118629	CH	45	2.1,5.6	X								B,E	PC3,4	119191	119148				
E17	118744	CH,BN	45	5.7,5	X								B,E	PC3,4	119191	119148				
E17	118744	CH,BN	45	5.7,5	X								B,E	PC1,2	119191	119148				
													B,E	PC3,4	119191	119148				
													B,E	PC3,4	119191	119148				
E12	118461	CH	10	2.1,4.2	X								B,E	PC3,4	119191	119148				
													B,E	PC3,4	119191	119148				
													B,E	PC3,4	119191	119148	20320	20321	20224	
E12	118461	CH	10	2.1,4.2	X								B,E	PC3,4	119191	119148	20320	20321	20224	
													B,E	PC3,4	119191	119148	20320	20321	20224	
E14	118511	CH	45	2.1,5.6	X								B,E	PC3,4	119191	119148	20320	20321	20224	
E15	118671	CH	45	4.2,7.5	X								B,E	PC3,4	119191	119148	20320	20321	20224	
													B,E	PC3,4	119191	119148				
E12	118461	CH	10	2.1,4.2	X								B,E	PC3,4	119191	119148				
													B,E	PC3,4	119191	119148	20320	20321	20224	
E12	118461	CH	10	2.1,4.2	X								B,E	PC3,4	119191	119148	20320	20321	20224	
E11	118467	CH	15	2.1,5.6	X								B,E	PC3	119191	119148	20320	20321	20224	

B 3 wire system. Converter required.
BN Exterior mounted plug on some or all models. May require an aftermarket electrical mounting box or bracket. (Sold separately)

CH T-One is equipped with circuit protected ModuLite® module.
E ModuLite® required.

RT1 Round Tube Class I 1-1/4"
RT2 Round Tube Class II 1-1/4"
RT3 Round Tube Class III 2"
SQ1 Square Tube Class I
SQ2 Square Tube Class II
SQ3 Square Tube Class III

MODEL / STYLE	YEAR	TRAILER HITCHES									
		PC	REC TYPE	REC SIZE	PART NO.	NO DRILL	FOOTNOTES	OPTIONAL DRAWBAR	WC (LBS.)	WD (LBS.)	IN
SUBARU (Continued)											
Tribeca	08-10	33	SQ3	2	75401	0	GP,JR		350/3,500	400/4,000	35
Tribeca	11-14	35	SQ3	2	75716	0	GP		525/3,500	525/5,250	30
WRX	18										
WRX STI	15-18	20	SQ1	1-1/4	24968	0	JR,KH	3593	200/2,000		60
XV Crosstrek Except Hybrid	13-15	19	SQ1	1-1/4	248861		HM,JR	3593	200/2,000		45
		19	RT1	1-1/4	24959		HM,JR	3593	200/2,000		30
		24	RT3	2	76084	0	HM,JR,KH,SV		525/3,500		20
XV Crosstrek Hybrid	13-15	19	SQ1	1-1/4	248861		HM,JR	3593	200/2,000		45
		19	RT1	1-1/4	24959		HM,JR	3593	200/2,000		30
SUZUKI											
Equator	09-12										
Equator w/Factory Tow Package	09-12	20	SQ3	2	75282	0	GP,TE		750/5,000	800/8,000	30
Grand Vitara	99-05	29	SQ1	1-1/4	24673	0	HM	3591	200/2,000		15
		29	SQ3	2	41537	0	HM		350/3,500		15
Grand Vitara Except 3 Dr Hatchback	06-13	24	SQ1	1-1/4	247641	0	EP,HM	3591	200/2,000		20
		30	SQ3	2	75448	0	EP		350/3,500	400/4,000	20
Sidekick Except Sport Model	96-98	24	SQ1	1-1/4	24622	0	HM	3593	200/2,000		20
Swift+ 5 Dr. (Canada Only)	04-09	20	SQ1	1-1/4	24741		GP	3593	200/2,000		30
SX4 Crossover	07-11	18	SQ1	1-1/4	24817		HM,JR	3594	200/2,000		40
Vitara	99-04	29	SQ1	1-1/4	24673	0	HM	3591	200/2,000		15
		29	SQ3	2	41537	0	HM		350/3,500		15
X-90	96-98	24	SQ1	1-1/4	24622	0	HM,HP	3593	200/2,000		20
XL-7	02-06	29	SQ1	1-1/4	24673	0	HM	3591	200/2,000		15
		29	SQ3	2	41537	0	HM		350/3,500		15
XL-7	07-09	29	SQ3	2	75529	0	HM		400/4,000	400/4,000	30
TESLA											
S	12-16	37	SQ1	1-1/4	24958	0	GP,AA,EP,DU,SV,TA	3593	200/2,000		150
X	16-17	40	SQ3	2	76143	0	GP,DU,SV,TZ,X		500/5,000		75
TOYOTA											
4Runner	96-00	42	RT3	2	75091	0			500/5,000	550/5,500	30
4Runner	01-02	42	RT3	2	75091	0			500/5,000	550/5,500	30
4Runner	03-06	47	RT4	2	75155	0	FE,LT,SI		600/6,000	730/7,300	35
4Runner w/Factory 7-Way	03-06										
4Runner	07-09	47	RT4	2	75155	0	FE,LT,SI		600/6,000	730/7,300	35
4Runner	10-11										
4Runner w/Factory 7-Way	10-11										
4Runner	14-16										
86	17-19	30	SQ1	1-1/4	24935	0	GP	3593	200/2,000		75
Avalon	95-99	23	SQ2	1-1/4	36336		HM	36061	300/3,500		15
Avalon	00-04	41	SQ2	1-1/4	36293		GP	36051	300/3,500		20
Avalon	05-10	50	SQ1	1-1/4	24870	0	HM,JR	3593	200/2,000		40
Avalon	11-12	50	SQ1	1-1/4	24870	0	HM,JR	3593	200/2,000		40
Avalon	13-18	23	SQ2	1-1/4	36540		HM,JR,KH,SV	36071	300/3,500		40
		19									
		22	SQ2	1-1/4	36643		HM,JR,KH,SV	36071	350/3,500		40
Camry 4 Dr. Sedan	97-01	34	SQ1	1-1/4	24715	0	HM,JR	3593	200/2,000		15
		23	SQ2	1-1/4	36336		HM	36061	300/3,500		15
Camry 4 Dr. Sedan	02-04	34	SQ1	1-1/4	24715	0	HM,JR	3593	200/2,000		15
		23	SQ2	1-1/4	36336		HM	36061	300/3,500		15
Camry 4 Dr. Sedan	05-06	23	SQ2	1-1/4	36336		HM	36061	300/3,500		15
AA	Requires temporary removal of bumper during installation.										
DU	Fascia removal required.										
EP	Fascia trimming may be required.										
FE	Fascia trimming may be required. Allow additional installation time.										
GP	Hitch cross-tube concealed behind bumper.										
HM	Hitch cross-tube is visible beneath bumper.										
HP	Requires four (4) 7/16 in. x 1 in. x 2 in. spacer blocks (#01080012) for installation. (Sold separately)										
JR	Exhaust must be temporarily lowered for installation.										
KH	Minor heat shield modification may be required.										
LT	Requires removal of factory hitch if equipped.										
SI	Hitches produced before 07/31/07 are rated at 350/3500 WC & 500/5000 WD.										
SV	Trimming or removal of under body appearance panel may be required.										
SY	Hitch cross-tube is visible beneath bumper with a more than normal gap between fascia and cross-tube.										
TA	Trunk access required for hitch installation.										
TE	Hitches produced before 04/20/11 are rated at 500/5000 WC.										
TZ	Requires replacement of the impact structure with hitch.										
X	Minor fascia trimming required.										

T-ONE						TOW HARNESS						4-FLAT WIRING				REQ. 4 FLAT WIRING		7-WAY HARDWARE	BRAKE CONTROL HARNESS	IN	
PC	T-ONE	FN	IN	AMP	CP	PC	TOW HARN	FN	IN	AMP	CP	TYPE	ELEC	POS	CHOICE 1	CHOICE 2	6-WAY ADAPTER				7-WAY ADAPTER
SUBARU (Continued)																					
E12	118461	CH	10	2.1,4.2	X								B,E	SUV8	119191	119148	20320	20321	20224		
E12	118461	CH	10	2.1,4.2	X								B,E	SUV8	119191	119148	20320	20321	20224		
E15	118768	CH	45	4.2,7.5	X								B,E	PC3,4							
E11	118467	CH	15	2.1,5.6	X								B,E	PC3,4	119191	119148					
													B,E	SUV1.2	119191	119148	20320	20321			
													B,E	SUV1.2	119191	119148	20320	20321			
SUZUKI																					
E14	118525		30	7.5		E21	118266	BN,RD	30			7-Way	H	PU3	119148	20252				3050-P	5
						E9	118267	BN,RD,Z	30			7-Way	B,E	PU3	119191	119148					
E5	118372	HG	5	2.1,5									B	SUV3	119130	119178	20320	20321	20224		
E12	118456	CG	20	2.1,5	X								B	SUV3,4	119130	119178	20320	20321	20224		
E5	118372	HG	5	2.1,5									B	SUV1.2	119130	119178					
													B	PC3,4	119130	119178					
E12	118456	CG	20	2.1,5	X								B	SUV1.2	119130	119178	20320	20321			
E5	118372	HG	5	2.1,5									B	SUV3	119130	119178	20320	20321	20224		
													B	SUV1.2	119130	119178					
E5	118372	HG	5	2.1,5									B	SUV3	119130	119178	20320	20321	20224		
						E7	118432	CE,RD	10	7.5		4-Flat	B	SUV1.2	119130	119178	20320	20321	20224		
TESLA																					
													BTT	PC3,4	119192	119191					
													B,E	SUV3,4							
TOYOTA																					
E11	118341	HG	20	2.1,5									B,E	SUV3,4	119191	119148	20320	20321	20224		
E11	118341	HG	20	2.1,5		E3	118245	BN,RD	10	7.5		4-Flat	B,E	SUV3,4	119191	119148	20320	20321	20224		
								RD					B	SUV1.2	119130	119178	20320	20321	20224	3040-P	5
													B	SUV1.2	118180	20252					
													B,E	SUV1.2	119191	119148	20320	20321	20224	3040-P	5
E8	118384	BN,RD	5	7.5		E12	118262	BN,RD	10			Both	A	SUV5	119148	20252				3040-P	5
E8	118384	BN,RD	5	7.5		E8	118384	BN,RD	5	7.5		4-Flat	A	SUV5	119148	20252				3040-P	5
							74682	RD	10			Both									
							85219	RD	5			7-Way									
																				3041-P	10
													B,E	PC3,4	119191	119148					
													B	PC3,4	119130	119178					
													B,E	PC3,4	119191	119148					
													B	PC3,4	119130	119178					
E17	118482	CH	45	2.1,5.6	X								B,E	PC3,4	119191	119148					
E16	118578	CH	45	4.2,7.5	X								B,E	PC3,4	119191	119148					
E16	118798	CH	45	5.7,5	X								B,E	PC3,4	119191	119148					
E10	118358	HG	5	2.1,5									B	PC3,4	119130	119178					
E10	118308		5	2.1,5									B	PC3,4	119130	119178					
E10	118308		5	2.1,5									B	PC3,4	119130	119178					

- A** 2 wire system.
- B** 3 wire system. Converter required.
- BN** Exterior mounted plug on some or all models. May require an aftermarket electrical mounting box or bracket. (Sold separately)
- BTT** Shared Brake/Tail/Turn multiplexed wiring system. ModuLite® HD Plus or Ultra required.
- CE** T-One includes fuse(s) & relay(s). Converter not required. Standard 2 wire system at factory tow plug.
- CG** T-One incorporates circuit protected taillight converter.
- CH** T-One is equipped with circuit protected ModuLite® module.
- E** ModuLite® required.
- H** 3 wire system with OEM standard 2 wire harness.
- HG** T-One incorporates taillight converter.
- RD** For vehicles equipped with factory tow package may require additional components or may be used as a replacement harness.
- Z** May be equipped with Factory Tow Prep Plug. Determine at time of installation.

- RT1** Round Tube Class I 1-1/4"
- RT3** Round Tube Class III 2"
- RT4** Round Tube Class IV 2"
- SQ1** Square Tube Class I
- SQ2** Square Tube Class II
- SQ3** Square Tube Class III

TOYOTA

RECEIVER HITCHES

RECEIVER HITCH APPLICATION GUIDE

MODEL / STYLE	YEAR	TRAILER HITCHES									
		PC	REC TYPE	REC SIZE	PART NO.	NO DRILL	FOOTNOTES	OPTIONAL DRAWBAR	WC (LBS.)	WD (LBS.)	IN
TOYOTA (Continued)											
Camry 4 Dr. Sedan, Except Hybrid	07-09	20	SQ2	1-1/4	36416		GP, JR, TA	36071	300/3,500		45
Camry 4 Dr. Sedan, Except Hybrid	10-11	20	SQ2	1-1/4	36416		GP, JR, TA	36071	300/3,500		45
Camry Including Hybrid	12-19	23	SQ2	1-1/4	36540		HM, JR, KH, SV	36071	300/3,500		40
Camry Except Hybrid	18-19	22	SQ2	1-1/4	36643		HM, JR, KH, SV	36071	350/3,500		40
Camry Hybrid 4 Dr. Sedan	07-11	20	SQ2	1-1/4	36416		GP, JR, TA	36071	300/3,500		45
C-HR	18	20	SQ1	1-1/4	24962	0	DU, GP, SV	3593	200/2,000		60
Corolla Sedan	93-02	25	SQ1	1-1/4	24579		GP	3592	200/2,000		30
Corolla	03	22	SQ1	1-1/4	248141	0	HM	3593	200/2,000		20
		23	RT1	1-1/4	24913	0	HM	3593	200/2,000		20
Corolla	04-07	22	SQ1	1-1/4	248141	0	HM	3593	200/2,000		20
		23	RT1	1-1/4	24913	0	HM	3593	200/2,000		20
Corolla	08	22	SQ1	1-1/4	248141	0	HM	3593	200/2,000		20
		23	RT1	1-1/4	24913	0	HM	3593	200/2,000		20
Corolla	09-13	22	SQ1	1-1/4	248141	0	HM	3593	200/2,000		20
		23	RT1	1-1/4	24913	0	HM	3593	200/2,000		20
Corolla Except Hatchback	14-19	23	RT1	1-1/4	24913	0	HM	3593	200/2,000		20
Corolla Hatchback	19										
Corolla Sedan	20	23	SQ1	1-1/4	24983	0		3593	200/2,000		40
Corolla iM	17	20	SQ1	1-1/4	24952	0	GP, JR, SV	3593	200/2,000		40
Corolla iM	18										
Echo Except Hatchback	00-02	33	SQ1	1-1/4	24813	0	X, GP	3590	200/2,000		15
Echo Except Hatchback	03-05	33	SQ1	1-1/4	24813	0	X, GP	3590	200/2,000		15
FJ Cruiser	07-14	34	SQ3	2	75461	0	GP		500/5,000	600/6,000	30
Highlander	01-03	39	SQ2	1-1/4	36271	0	HM	36051	300/3,500		15
		35	SQ3	2	41541	0	HM		300/3,500		15
Highlander	04-07	32	RT3	2	75153	0	HM		350/3,500		20
Highlander Except Hybrid	04-07										
Highlander	08-13	45	RT3	2	75726	0	HM, SV		750/5,000	750/5,000	40
Highlander Except w/Full Size 19" Spare Tire	08-13	35	SQ3	2	75586	0	HM		500/5,000	500/5,000	25
Highlander	14-19	42	SQ3	2	76156	0	GP, SV		500/5,000		45
		36	RT4	2	75896	0	HM, SV		900/6,000	900/8,000	30
Hilux	08-12	53	SQ4	2	75730	0	AA, GP		900/6,000	900/9,000	60
Hilux	13-14	53	SQ4	2	75730	0	AA, GP		900/6,000	900/9,000	60
Hilux	16-17	38	SQ4	2	75791	0	HM		800/8,000	800/8,000	45
Hilux SW4	14	38	SQ3	2	75914	0	HM		525/3,500		15
Land Cruiser	96-97	54	SQ3	2	41015	0	HM		500/5,000	750/6,000	30
Land Cruiser	98-99	45	SQ3	2	75095	0	GP		500/5,000	750/6,000	20
Land Cruiser	00	45	SQ3	2	75095	0	GP		500/5,000	750/6,000	20
Land Cruiser	01-02	45	SQ3	2	75095	0	GP		500/5,000	750/6,000	20
Land Cruiser	03-07	45	SQ3	2	75095	0	GP		500/5,000	750/6,000	20
Matrix	03-08	15	SQ1	1-1/4	24812	0	HM, UD	3593	200/2,000		15
Matrix	09-13	15	SQ1	1-1/4	24812	0	HM	3593	200/2,000		15
Matrix (Canada Only)	14	15	SQ1	1-1/4	24812	0	HM	3593	200/2,000		15
Prado	14	38	SQ4	2	75904	0	GP		825/5,500	825/5,500	15
Prius	04-09	24	SQ1	1-1/4	24808	0	HM, SC	3593	200/2,000		30
Prius Except w/Plug-In Model	10-15	18	SQ1	1-1/4	24847	0	HM, JR	3593	200/2,000		25
		21	SQ1	1-1/4	24967	0	GP, SV	3593	200/2,000		40
Prius Except Prius Prime	16-19	16	SQ1	1-1/4	249441	0	DU, GP, SV	3593	200/2,000		45
		16	SQ1	1-1/4	24966	0	DU, GP, SV	3592	200/2,000		45
Prius C	12-17	23	SQ1	1-1/4	24889	0	GP	3593	200/2,000		20
Prius C	12-19	24	SQ1	1-1/4	24971	0	GP	3593	200/2,000		20
Prius Plug-In	12-15	21	SQ1	1-1/4	24967	0	GP, SV	3593	200/2,000		40
Prius Prime	17-18	16	SQ1	1-1/4	24966	0	DU, GP, SV	3592	200/2,000		45

AA Requires temporary removal of bumper during installation.
 DU Fascia removal required.
 GP Hitch cross-tube concealed behind bumper.
 HM Hitch cross-tube is visible beneath bumper.
 JR Exhaust must be temporarily lowered for installation.
 KH Minor heat shield modification may be required.

SC Minor trimming of plastic trunk pan required.
 SV Trimming or removal of under body appearance panel may be required.
 TA Trunk access required for hitch installation.
 UD Fascia removal required on XR & XRS models.
 X Minor fascia trimming required.

T-ONE						TOW HARNESS						4-FLAT WIRING				REQ. 4 FLAT WIRING		7-WAY HARDWIRE	BRAKE CONTROL HARNESS	IN
PC	T-ONE	FN	IN	AMP	CP	PC	TOW HARN	FN	IN	AMP	CP	TYPE	ELEC	POS	CHOICE 1	CHOICE 2	6-WAY ADAPTER			
TOYOTA (Continued)																				
E16	118405	CH	45	2.1,5.6	X								B,E	PC3,4	119191	119148				
E17	118482	CH	45	2.1,5.6	X								B,E	PC3,4	119191	119148				
E16	118405	CH	45	2.1,5.6	X								B,E	PC3,4	119191	119148				
E15	118763	CH	45	5.7,5	X								B,E	PC3,4	119191	119148				
E17	118482	CH	45	2.1,5.6	X								B,E	PC3,4	119191	119148				
E17	118756	CH,BN	45	5.7,5	X								B,E	SUV1,2						
													B	PC3,4	119130	119178				
E13	118387	CG	15	2.1,5	X								B	PC3,4	119130	119178				
													B	PC3,4	119130	119178				
													B,E	PC3,4	119191	119148				
E16	118459	CH	45	2.1,4.2	X								B,E	PC3,4	119191	119148				
E16	118405	CH	45	2.1,5.6	X								B,E	PC3,4	119191	119148				
E16	118729	CH,BN	45	5.7,5	X								B,E	PC3,4	119191	119148				
E17	118810	CH	45	5.7,5	X								B,E	PC3,4	119191	119148				
E16	118729	BN,CH	45	5.7,5	X								B,E	PC3,4						
E16	118729	BN,CH	45	5.7,5	X								B,E	PC3,4						
E12	118386	CG	20	2.1,5	X								B	PC3,4	119130	119178				
													B	PC3,4	119130	119178				
E16	118405	CH	45	2.1,5.6	X								B	SUV3,4	119130	119178	20320	20321	20224	
E10	118413	HG	20	2.1,4.2		E3	118245	BN,RD	10	7.5		4-Flat	B,Z	SUV3,4	119178	119130	20320	20321	20224	
E10	118248	CH	20	2.1,4.2	X	E10	118248	RD	20	2.1,4.2	X	4-Flat	B	SUV3	119130	119178	20320	20321	20224	
E10	118413	HG	20	2.1,4.2									B	SUV3,4	119130	118178				
E13	118449	CH	20	2.1,4.2	X								B,E	SUV3,4	119191	119148	20320	20321	20224	
E13	118449	CH	20	2.1,4.2	X								B,E	SUV3,4	119191	119148	20320	20321	20224	
E13	118449	CH	20	2.1,4.2	X		22119	BN	60			7-Way	B,E	SUV3,4	119191	119148	20320	20321	20224	
E13	118496	HG	10	2.1,7.5									B	PU3,4	119130	119178	20320	20321	20224	
													B	PU3,4	119130	119178	20320	20321	20224	
													B,E	PU3,4	119191	119148				
													B,E	PU3,4	119191	119148	20320	20321		
E7	118357	BN,HG	5	2.1,5									B	SUV6	119130	119178	20320	20321	20224	
E7	118365	BN,HG	5	2.1,5									B	SUV6	119130	119178	20320	20321	20224	
													B	SUV6	119130	119178	20320	20321	20224	
						E3	118245	BN,RD	10	7.5		4-Flat	B	SUV6	119130	119178	20320	20321	20224	
													B	SUV6	119130	119178	20320	20321	20224	3040-P
E12	118386	CG	20	2.1,5	X								B	SUV3,4	119130	119178				
E16	118460	CH	45	2.1,4.2	X								B,E	SUV3,4	119191	119148	20320	20321		
													B,E	SUV3,4	119191	119148	20320	20321		
													B,E	SUV3,4	119191	119148	20320	20321		
E16	118505	CH	25	2.1,5.6	X								B,E	PC3,4	119191	119148				
E16	118505	CH	25	2.1,5.6	X								B,E	PC3,4	119191	119148				
E17	118701	CH	45	4.2,7.5	X								B,E	PC3,4	119191	119148				
E13	118680	CH	25	4.2,7.5	X								B,E	PC3,4	119191	119148				
E13	118680	CH	25	4.2,7.5	X								B,E	PC3,4	119191	119148				
E16	118505	CH	25	2.1,5.6	X								B,E	PC3,4	119191	119148				
															119191	119148				

B 3 wire system. Converter required.
BN Exterior mounted plug on some or all models. May require an aftermarket electrical mounting box or bracket. (Sold separately)
CG T-One incorporates circuit protected taillight converter.
CH T-One is equipped with circuit protected ModuLite® module.
E ModuLite® required.
HG T-One incorporates taillight converter.
RD For vehicles equipped with factory tow package may require additional components or may be used as a replacement harness.
Z May be equipped with Factory Tow Prep Plug. Determine at time of installation.

RT1 Round Tube Class I 1-1/4"
RT3 Round Tube Class III 2"
RT4 Round Tube Class IV 2"
SQ1 Square Tube Class I
SQ2 Square Tube Class II
SQ3 Square Tube Class III
SQ4 Square Tube Class IV

TOYOTA

RECEIVER HITCHES

RECEIVER HITCH APPLICATION GUIDE

MODEL / STYLE	YEAR	TRAILER HITCHES									
		PC	REC TYPE	REC SIZE	PART NO.	NO DRILL	FOOTNOTES	OPTIONAL DRAWBAR	WC (LBS.)	WD (LBS.)	IN
TOYOTA (Continued)											
Prius V	12-17	18	SQ1	1-1/4	24847	0	HM,JR	3593	200/2,000		25
		21	SQ1	1-1/4	24967	0	GP,SV	3593	200/2,000		40
RAV4	96-00	31	SQ1	1-1/4	24704	0	HM	3593	200/2,000		15
		31	SQ3	2	75125	0	RA		350/3,500		15
RAV4	01-05	31	SQ1	1-1/4	24704	0	HM	3593	200/2,000		15
		31	SQ3	2	75125	0			350/3,500		15
RAV4	06-12	24	RT2	1-1/4	36588	0	HM,JR,SV	36051	300/3,500		20
		20	RT3	2	75235	0	HM,JR,SV		675/4,500	675/4,500	20
RAV4	13-15	24	RT2	1-1/4	36588	0	HM,JR,SV	36051	300/3,500		20
		26	RT3	2	76134	0	JR,GP,TA,HX,DU,SV		350/3,500		20
		20	RT3	2	75235	0	HM,JR,SV		675/4,500	675/4,500	20
RAV4	16-18	24	RT2	1-1/4	36588	0	HM,JR,SV,TW	36051	300/3,500		20
		26	RT3	2	76134	0	JR,GP,TA,HX,SV,TW		350/3,500		45
		20	RT3	2	75235	0	HM,JR,SV,TW		675/4,500	675/4,500	20
RAV4	19	24	SQ2	1-1/4	36675	0	CH,BN		350/3,500		35
		29	SQ3	2	76201	0	CH,BN		675/4,500	675/4,500	35
Sequoia Except Models w/OEM Hitch	01-02	57	SQ3	2	75126	0	CP		500/5,000	650/6,500	20
Sequoia Except Models w/OEM Hitch	03-07	57	SQ3	2	75126	0	CP		500/5,000	650/6,500	20
Sequoia w/Factory 7-Way	03-04										
Sequoia	08-10	19	SQ4	2	75649	0	AI		600/6,000	1,000/10,000	40
Sequoia	11-19	19	SQ4	2	75649	0	AI		600/6,000	1,000/10,000	40
Sienna	98-03	34	SQ2	1-1/4	36298	0	GP	36053	300/3,500		15
		34	SQ3	2	75120				350/3,500	500/5,000	30
Sienna	04-10	27	RT2	1-1/4	36513	0	HM,JR	36051	300/3,500		20
		23	RT3	2	75237	0	HM,SV,JR,SY		675/4,500	675/5,000	30
Sienna	11-14	27	RT2	1-1/4	36513	0	HM,JR,SV,SY	36051	300/3,500		20
		32	SQ4	2	76112	0	SV,JR,GP,TA,DU		525/3,500	525/3,500	60
		23	RT3	2	75237	0	HM,SV,JR,SY		675/4,500	675/5,000	30
Sienna Except SE	15-20	27	RT2	1-1/4	36513	0	HM,JR,SV,SY	36051	300/3,500		20
		32	SQ4	2	76112	0	SV,JR,GP,TA,DU		525/3,500	525/3,500	60
		23	RT3	2	75237	0	HM,SV,JR,SY		675/4,500	675/5,000	30
Sienna SE	15-20	27	RT2	1-1/4	36513	0	HM,JR,SV,SY	36051	300/3,500		20
		32	SQ4	2	76112	0	SV,JR,GP,TA,DU		525/3,500	525/3,500	60
		23	RT3	2	75237	0	HM,SV,JR,SY		675/4,500	675/5,000	30
Solara	99-03	34	SQ1	1-1/4	24715	0	HM,JR	3593	200/2,000		15
		23	SQ2	1-1/4	36336	0	HM	36061	300/3,500		15
Solara	04-06	39	SQ2	1-1/4	36378	0	JR,HM	36061	300/3,500		15
Solara	07-08	39	SQ2	1-1/4	36378	0	JR,HM	36061	300/3,500		15
T100	93-98	59	SQ3	2	75144	0	CN		500/5,000	700/7,000	45
Tacoma (App. starts with 95-1/2)	95-04	32	SQ3	2	75078	0	GP		500/5,000	550/5,500	40
Tacoma Except X-Runner	05-08	15	SQ3	2	75236	0	GP		500/5,000	550/5,500	30
Tacoma Except X-Runner	09-15	15	SQ3	2	75236	0	GP		500/5,000	550/5,500	30
Tacoma w/Factory 7-Way	09-12										
Tacoma	16-19	20	SQ4	2	75238	0	GP		1,050/7,000	1,200/8,000	20
Tercel Sedan	91-98	31	SQ1	1-1/4	246061	0	HM	3593	200/2,000		30
Tundra	00	49	RT3	2	37133				500/5,000	750/7,500	35
		30	SQ3	2	75105	0	GP		500/5,000	750/7,500	15
		54	RT4	2	37130				700/7,000	1,200/12,000	30
Tundra	01-02	49	RT3	2	37133				500/5,000	750/7,500	35
		30	SQ3	2	75105	0	GP		500/5,000	750/7,500	15
		54	RT4	2	37130				700/7,000	1,200/12,000	30

AI Additional installation time may be required.

BN Exterior mounted plug on some or all models. May require an aftermarket electrical mounting box or bracket. (Sold separately)

CH T-One is equipped with circuit protected ModuLite® module.

CN Requires OEM factory bumper for hitch installation.

CP Fits all models without factory installed receiver.

DU Fascia removal required.

GP Hitch cross-tube concealed behind bumper.

HM Hitch cross-tube is visible beneath bumper.

HX Minor exhaust modification may be required.

JR Exhaust must be temporarily lowered for installation.

RA Do not install on early 1996 models equipped with M10 fasteners.

SV Trimming or removal of under body appearance panel may be required.

SY Hitch cross-tube is visible beneath bumper with a more than normal gap between fascia and cross-tube.

TA Trunk access required for hitch installation.

TW Receiver hitch may limit hands-free liftgate sensor range

T-ONE					TOW HARNESS					4-FLAT WIRING				REQ. 4 FLAT WIRING		7-WAY HARDWARE	BRAKE CONTROL HARNESS	IN	
PC	T-ONE	FN	IN	AMP	CP	PC	TOW HARN	FN	IN	AMP	CP	TYPE	ELEC	POS	CHOICE 1				CHOICE 2
TOYOTA (Continued)																			
E13	118610	CH	45	2.1,5.6	X								B,E	PC3,4	119191	119148			
E12	118388	CG	20	2.1,5	X								B	SUV3,4	119130	119178	20320	20321	20224
E12	118389	CG	20	2.1,5	X								B	SUV3,4	119130	119178	20320	20321	20224
E16	118412	CH	45	2.1,4.2	X								B,E	SUV3,4	119191	119148	20320	20321	20224
E16	118578	CH	45	4.2,7.5	X								B,E	SUV3,4	119191	119148	20320	20321	20224
E16	118578	CH	45	4.2,7.5	X								B,E	SUV3,4	119191	119148	20320	20321	20224
E16	118801		45	5.7,5	X								B,E	SUV3,4	119191	119148			
						E1	118246	BN,RD	5	7.5		4-Flat	B	SUV7	119130	119178	20320	20321	20224
													D			119251	20320	20321	3040-P 5
								RD					RD	SUV6		119251			
E16	118412	CH	45	2.1,4.2	X								N	SUV3,4		119251	20320	20321	3040-P 5
													D			119251	20320	20321	3040-P 5
													B	SUV3,4	119130	119178	20320	20321	20224
E10	118304		20	2.1,4.2									B	SUV1,2	119130	119178	20320	20321	20224
E18	118498	CH	45	2.1,5.6	X								B,E	SUV1,2	119191	119148	20320	20321	20224
E16	118648	CH	45	4.2,7.5	X								B,E	SUV1,2	119191	119148	20320	20321	20224
E18	118498	CH	45	2.1,5.6	X								B,E	SUV1,2	119191	119148	20320	20321	20224
													B	PC3,4	119130	119178			
													B,E	PC3,4	119191	119148			
E13	118496	HG	10	2.1,7.5									B	PU3,4	119130	119178	20320	20321	20224
E14	118379	BN,HG	10	2.1,5									B	PU1,2	119130	119178	20320	20321	20224
E13	118496	HG	10	2.1,7.5									B	PU1,2	119130	119178	20320	20321	20224 3040-P 5
E13	118496	HG	10	2.1,7.5		E8	118384	BN,RD	5	7.5		4-Flat	B,E	PU1,2	119191	119148	20320	20321	20224 3040-P 5
							74682	RD	10			Both	H	PU3	119148	20252			
							85219	RD	5			7-Way							
E21	118685	BN,CH	45	5.7,5	X		22117		60			7-Way	B,E	PU1,2	119191	119148			3031-P 5
													B	PC3,4	119130	119178			
E15	118367	BN,CH	10	7.5									B,E	PU3	119191	119148	20320	20321	20224
E17	118378	BN,CH	10	7.5									B,E	PU3	119191	119148	20320	20321	20224

B 3 wire system. Converter required.
BN Exterior mounted plug on some or all models. May require an aftermarket electrical mounting box or bracket. (Sold separately)
CG T-One incorporates circuit protected taillight converter.
CH T-One is equipped with circuit protected ModuLite® module.
D See auto dealer for trailer tow wiring kit.
E ModuLite® required.
H 3 wire system with OEM standard 2 wire harness.
HG T-One incorporates taillight converter.
N DO NOT cut or splice vehicle wiring. Only use approved T-One or see auto dealer for trailer tow wiring kit.
RD For vehicles equipped with factory tow package may require additional components or may be used as a replacement harness.

RT2 Round Tube Class II 1-1/4"
RT3 Round Tube Class III 2"
RT4 Round Tube Class IV 2"
SQ1 Square Tube Class I
SQ2 Square Tube Class II
SQ3 Square Tube Class III
SQ4 Square Tube Class IV

MODEL / STYLE	YEAR	TRAILER HITCHES									
		PC	REC TYPE	REC SIZE	PART NO.	NO DRILL	FOOTNOTES	OPTIONAL DRAWBAR	WC (LBS.)	WD (LBS.)	IN
TOYOTA (Continued)											
Tundra	03-06	49	RT3	2	37133	0	GP		500/5,000	750/7,500	35
		30	SQ3	2	75105	0			500/5,000	750/7,500	15
		54	RT4	2	37130				700/7,000	1,200/12,000	30
Tundra w/Factory 7-Way	03-06										
Tundra (See Footnote CP)	07-09	25	RT4	2	75527	0	CP,HM		600/6,000	800/8,000	20
		67	SQ5	2	41935	0	@,CP,HM		1,200/12,000	1,400/14,000	30
Tundra (See Footnote CP)	10-14	25	RT4	2	75527	0	CP,HM		600/6,000	800/8,000	20
		67	SQ5	2	41935	0	@,CP,HM		1,200/12,000	1,400/14,000	30
Tundra w/Factory 7-Way	10-13										
Tundra (See Footnote CP)	15-17	25	RT4	2	75527	0	CP,HM		600/6,000	800/8,000	20
		67	SQ5	2	41935	0	@,CP,HM		1,200/12,000	1,400/14,000	30
Tundra (See Footnote CP)	18-19	25	RT4	2	75527	0	CP,HM		600/6,000	800/8,000	20
		67	SQ5	2	41935	0	@,CP,HM		1,200/12,000	1,400/14,000	30
Venza	09-16	29	RT2	1-1/4	36512	0	HM,JR	36061	300/3,500		20
		38	RT3	2	75663	0	HM,JR		350/3,500	400/4,000	20
Yaris 3 Dr. Liftback	07-11	11	SQ1	1-1/4	24819	0	GP	3593	200/2,000		20
Yaris 3 Dr. Liftback	07-14	14	SQ1	1-1/4	24911	0	GP	3593	200/2,000		20
Yaris 4 Dr. Sedan	07-11	11	SQ1	1-1/4	24819	0	GP	3593	200/2,000		20
Yaris 5 Dr. Liftback, Except SE	07-14	14	SQ1	1-1/4	24911	0	GP	3593	200/2,000		20
Yaris 5 Dr. Liftback	09-11	11	SQ1	1-1/4	24819	0	GP	3593	200/2,000		20
Yaris Except SE	15-19	16	SQ1	1-1/4	24929	0	GP,EP	3593	200/2,000		25
Yaris iA	17-18	32	RT1	1-1/4	24948	0	HM	3593	200/2,000		30
VOLKSWAGEN											
Amarok (International Only)	13	59	SQ3	2	75808†	0	HM		600/4,000	800/8,000	30
Atlas	18-19	30	SQ2	1-1/4	36635	0	GP	36051	350/3,500		25
		31	SQ4	2	76176		GP		900/6,000	900/6,000	25
Beetle	98-01	39	SQ1	1-1/4	24679		TA,GP	3593	200/2,000		30
Beetle Except Turbo S	02-10	39	SQ1	1-1/4	24679		TA,GP	3593	200/2,000		30
Beetle Except Convertible & Gas Turbo	12-13	27	SQ1	1-1/4	24877†	0	HM,JR	3594	200/2,000		20
Beetle Gas Turbo, Except Convertible	12-13	29	SQ1	1-1/4	24879		GP,JR	3594	200/2,000		30
Beetle Except R-Line & GSR	14-19	28	SQ1	1-1/4	24922	0	HM	3593	200/2,000		20
Beetle	18-19										
CC Except 4 Motion	09-12	22	SQ1	1-1/4	24848		HM,JR,X	3594	200/2,000		35
CC Except 4 Motion	13-17	22	SQ1	1-1/4	24848		HM,JR,X	3594	200/2,000		35
Eos	07-13	25	SQ1	1-1/4	24824	0	GP,JR	3594	200/2,000		40
Golf	99-06	39	SQ1	1-1/4	24679		TA,GP	3594	200/2,000		30
Golf 2 Dr. Hatchback, Except R	10-13	19	SQ1	1-1/4	24825	0	HM	3594	200/2,000		15
Golf 4 Dr. Hatchback, Except R	10-14	19	SQ1	1-1/4	24825	0	HM	3594	200/2,000		15
Golf Hatchback (Canada Only), Except R	10-13	19	SQ1	1-1/4	24825	0	HM	3594	200/2,000		15
Golf Wagon (Canada Only)	10-14	23	SQ1	1-1/4	24866	0	HM,JR,TA	3594	200/2,000		40
Golf	15-17	25	SQ1	1-1/4	24925	0	TA,FE,GP	3593	200/2,000		60
Golf Except Sportwagen Models	18-19										
Golf Alltrack	17	19	SQ1	1-1/4	24949	0	EP,GP,DU,AA	3590	200/2,000		60
Golf Alltrack	18-19	19	SQ1	1-1/4	24949	0	EP,GP,DU,AA	3590	200/2,000		60
Golf City (Canada Only)	07-10	39	SQ1	1-1/4	24679		TA,GP	3594	200/2,000		30
Golf R	15-18	30	SQ1	1-1/4	24975	0	DU,GP,TA,X	3593	200/2,000		75
Golf SportWagen	15	19	SQ1	1-1/4	24949	0	EP,GP,DU,AA	3590	200/2,000		60
Golf SportWagen	16-17	19	SQ1	1-1/4	24949	0	EP,GP,DU,AA	3590	200/2,000		60
GTI 2 Dr. Hatchback	06-09	19	SQ1	1-1/4	24825	0	HM	3594	200/2,000		15
GTI 4 Dr. Hatchback	07-09	19	SQ1	1-1/4	24825	0	HM	3594	200/2,000		15
GTI Hatchback	10-14	28	SQ1	1-1/4	24904	0	JR,KH,GP	3594	200/2,000		40
GTI Hatchback (Canada Only)	10-12	28	SQ1	1-1/4	24904	0	JR,KH,GP	3594	200/2,000		40

@ Ultra Frame ball mount must be used to achieve maximum weight carrying rating.
AA Requires temporary removal of bumper during installation.
CP Fits all models without factory installed receiver.
DU Fascia removal required.
EP Fascia trimming may be required.
FE Fascia trimming may be required. Allow additional installation time.

GP Hitch crosstube concealed behind bumper.
HM Hitch crosstube is visible beneath bumper.
JR Exhaust must be temporarily lowered for installation.
KH Minor heat shield modification may be required.
TA Trunk access required for hitch installation.
X Minor fascia trimming required.

T-ONE					TOW HARNESS					4-FLAT WIRING				REQ. 4 FLAT WIRING		7-WAY HARDWARE	BRAKE CONTROL HARNESS	IN			
PC	T-ONE	FN	IN	AMP	CP	PC	TOW HARN	FN	IN	AMP	CP	TYPE	ELEC	POS	CHOICE 1				CHOICE 2	6-WAY ADAPTER	7-WAY ADAPTER
TOYOTA (Continued)																					
													B,E	PU3,4	119191	119148	20320	20321	20224	3040-P	5
							20137	RD	10			Both	B,E	PU3,4	119191	119148					
													A	PU3	119148	20252	20320	20321	20224	3040-P	5
						E8	118384	BN,RD	5	7.5		4-Flat	A	PU3	119148	20252	20320	20321	20224	3040-P	5
							74682 85219	RD RD	10 5			Both 7-Way	H	PU3	119148	20252					
						E8	118384	BN,RD	5	7.5		4-Flat	A	PU3	119148	20252	20320	20321	20224	3031-P	5
													A	PU3							
E17	118482	CH	45	2.1,5.6	X								B,E	SUV3,4	119191	119148	20320	20321	20224		
													B	PC3,4	119130	119178					
													B	PC3,4	119130	119178					
E18	118517	CH	45	2.1,5.6	X								B	PC3,4	119130	119178					
													B	PC3,4	119130	119178					
													B	PC3,4	119130	119178					
E16	118661	CH	45	4.2,7.5	X								B,E	PC3,4	119191	119148					
E15	118728	CH,BN	45	5.7,5	X								B,E	PC1,2	119191	119148					
VOLKSWAGEN																					
E19	118754	CH	45	5.7,5	X	E8	118384	BN,RD	5	7.5		4-Flat	BM	PU3	119251	119191	20320	20321			
													BT	SUV3,4							
													B	PC1,2	119130	119178					
													B	PC1,2	119130	119178					
E17	118688	CH	45	4.2,7.5	X								B,E	PC3,4	119251	119191					
E17	118688	CH	45	4.2,7.5	X								B,E	PC3,4	119251	119191					
E17	118688	CH	45	4.2,7.5	X								B,E	PC3,4	119251	119191					
E17	118688	CH	45	4.2,7.5	X								B,E	PC3,4	119251	119191					
E16	118714	CH	45	4.2,7.5	X								BT	PC1,2	119251	119191					
													A,E	PC3,4	119251	119148					
													BM	PC3,4	119251	119191					
													B	PC1,2	119130	119178					
													BT	PC1,2	119251	119191					
													BT	PC1,2	119251	119191					
													BT	PC1,2	119251	119191					
													BM	PC3,4	119251	119191					
E20	118646	CH	45	4.2,7.5	X								BTT	PC3,4	119251	119191					
E20	118646	CH	45	4.2,7.5	X								BTT	PC3,4	119251	119191					
E17	118730	CH	45	5.7,5	X								B,E	PC3,4							
													B,E	PC3,4							
													B	PC1,2	119130	119178					
E19	118787	CH	45	5.7,5	X								A,E	PC3,4	119191	119148					
E17	118730	CH	45	5.7,5	X								A,E	PC3,4	119191	119148					
													BTT	PC1,2	119192	119191					
													BTT	PC1,2	119251	119191					
													BM	PC3,4	119251	119191					
													BM	PC3,4	119251	119191					

- A** 2 wire system.
- B** 3 wire system. Converter required.
- BM** Multiplexed wiring system. ModuLite® HD Plus or Ultra required.
- BN** Exterior mounted plug on some or all models. May require an aftermarket electrical mounting box or bracket. (Sold separately)
- BT** Shared Brake/Tail multiplexed wiring system. ModuLite® HD Plus or Ultra required.
- BTT** Shared Brake/Tail/Turn multiplexed wiring system. ModuLite® HD Plus or Ultra required.
- CH** T-One is equipped with circuit protected ModuLite® module.
- E** ModuLite® required.
- H** 3 wire system with OEM standard 2 wire harness.
- RD** For vehicles equipped with factory tow package may require additional components or may be used as a replacement harness.

- RT1** Round Tube Class I 1-1/4"
- RT2** Round Tube Class II 1-1/4"
- RT3** Round Tube Class III 2"
- RT4** Round Tube Class IV 2"
- SQ1** Square Tube Class I
- SQ2** Square Tube Class II
- SQ3** Square Tube Class III
- SQ4** Square Tube Class IV
- SQ5** Square Tube Class V

VOLKSWAGEN

RECEIVER HITCHES

MODEL / STYLE	YEAR	PC	TRAILER HITCHES								
			REC TYPE	REC SIZE	PART NO.	NO DRILL	FOOTNOTES	OPTIONAL DRAWBAR	WC (LBS.)	WD (LBS.)	IN
VOLKSWAGEN (Continued)											
GTI	16-17	25	SQ1	1-1/4	24925	0	TA,FE,GP	3593	200/2,000		60
GTI	18-19	30	SQ1	1-1/4	24979	0	GP,AA,SV,TA	3593	200/2,000		80
Jetta Jetta III	94-98	35	SQ1	1-1/4	245941		GP	3592	200/2,000		30
Jetta Sedan, Except Gas Turbo & Wagon	99-04	29	SQ1	1-1/4	24748		TA,HM	3593	200/2,000		30
Jetta 4 Dr. Sedan	05-10	23	SQ1	1-1/4	24866	0	HM,JR,TA	3594	200/2,000		40
Jetta Sedan, Except Gas Turbo & Wagon	05	29	SQ1	1-1/4	24748		TA,HM	3593	200/2,000		30
Jetta SportWagon	09-14	23	SQ1	1-1/4	24866	0	HM,JR,TA	3594	200/2,000		40
Jetta 4 Dr. Sedan	11-14	23	SQ1	1-1/4	24866	0	HM,JR,TA	3594	200/2,000		40
Jetta 4 Dr. Sedan, Except Hybrid & TDI	15-18	33	RT1	1-1/4	24926	0	JR,HM,TA,SV	3593	200/2,000		40
Jetta	19	37	SQ1	1-1/4	24978	0	GP,AA,X,TA	3593	200/2,000		80
Jetta City Sedan (Canada Only)	07-09	29	SQ1	1-1/4	24748		TA,HM	3593	200/2,000		30
Passat 4 Dr. Sedan, Except 4 Motion & W8 Engine	99-05	20	SQ1	1-1/4	24698		RB,TA,HM	3593	200/2,000		40
Passat Wagon, Except 4 Motion & W8 Engine	99-05	20	SQ1	1-1/4	24698		RB,TA,HM	3593	200/2,000		40
Passat 4 Dr. Sedan, Except 4 Motion	06-10	22	SQ1	1-1/4	24848		HM,JR,X	3594	200/2,000		35
Passat Wagon, Except 4 Motion	07-10	22	SQ1	1-1/4	24848		HM,JR,X	3594	200/2,000		35
Passat 4 Dr. Sedan	12-15	34	SQ1	1-1/4	24880	0	EP,GP,JR,SV,TA	3590	200/2,000		30
Passat Except SE & SEL	16	34	SQ1	1-1/4	24880	0	EP,GP,JR,SV,TA,TW	3590	200/2,000		30
Passat SE & SEL Only	16	34	SQ1	1-1/4	24880	0	EP,GP,JR,SV,TA,TW	3590	200/2,000		30
Passat	17-19	34	SQ1	1-1/4	24880	0	EP,GP,JR,SV,TA,TW	3590	200/2,000		30
Rabbit	06-09	19	SQ1	1-1/4	24825	0	HM	3594	200/2,000		15
Routan	09-12	24	SQ2	1-1/4	36455	0	GP,JR	36061	300/3,500		20
		19	SQ3	2	75579	0	GP,JR		400/4,000	500/5,000	20
Routan (Canada Only)	13-14	24	SQ2	1-1/4	36455	0	GP,JR	36061	300/3,500		20
		19	SQ3	2	75579	0	GP,JR		400/4,000	500/5,000	20
Tiguan	09-11	10	SQ2	1-1/4	36474	0	EP,HM	36051	300/3,500		20
		10	SQ3	2	75658	0	EP		350/3,500		20
Tiguan	12-17	10	SQ2	1-1/4	36474	0	EP,HM	36051	300/3,500		20
		10	SQ3	2	75658	0	EP		350/3,500		20
Tiguan 4 Motion	18-19	25	SQ2	1-1/4	36650	0	GP,JR	36051	350/3,500		20
		26	SQ3	2	76192	0	EP,GP,JR		675/4,500	675/4,500	40
Tiguan Except 4 Motion	18-19	25	SQ2	1-1/4	36650	0	GP,JR	36051	350/3,500		20
		26	SQ3	2	76192	0	EP,GP,JR		675/4,500	675/4,500	40
Tiguan 4 Motion	19				0						
Tiguan Limited	18										
Touareg	04-10	47	SQ4	2	75363		AA,RB		600/6,000	600/6,000	90
Touareg	11-17	45	SQ4	2	75950	0	GP,EP,TA		750/7,500		70
Transporter	93-03										
VOLVO											
850 Sedan	93-97	29	SQ2	1-1/4	36262		GP,JR	36061	300/3,500		20
850 Wagon	94-97	29	SQ2	1-1/4	36262	0	GP	36061	300/3,500		20
C30	08-10	28	SQ1	1-1/4	248111		HM,JR,KH	3593	200/2,000		45
C70 Convertible	98-04	29	SQ2	1-1/4	36262		GP,JR	36061	300/3,500		20
C70 Coupe	98-02	29	SQ2	1-1/4	36262		GP,JR	36061	300/3,500		20
S40 Sedan (App. starts with 2004-1/2)	04-11	27	SQ1	1-1/4	24781	0	GP,JR	3594	200/2,000		25
S60 Sedan	01-09	37	SQ2	1-1/4	36297	0	HM,JR	36061	300/3,500		15
S60 Sedan	11-13	27	SQ3	2	75916	0	DU,EP,GP		400/4,000		70
S60 Sedan	14-18	27	SQ3	2	75916	0	DU,EP,GP		400/4,000		70
S70 Sedan	98-00	29	SQ2	1-1/4	36262		GP,JR	36061	300/3,500		20
S80 Sedan	07-16	22	SQ2	1-1/4	36466	0	HM,JR,KH	36061	300/3,500		35
S90	17-18										
V50 Wagon, Except T5 R-Design	05-10	27	SQ1	1-1/4	24781	0	GP,JR	3594	200/2,000		25
V60 (App. starts with 2015-1/2)	15-17	27	SQ3	2	75916	0	DU,EP,GP		400/4,000		70
V70 Wagon	98-00	29	SQ2	1-1/4	36262	0	GP	36061	300/3,500		20

AA Requires temporary removal of bumper during installation.

DU Fascia removal required.

EP Fascia trimming may be required.

FE Fascia trimming may be required. Allow additional installation time.

GP Hitch cross-tube concealed behind bumper.

HM Hitch cross-tube is visible beneath bumper.

JR Exhaust must be temporarily lowered for installation.

KH Minor heat shield modification may be required.

RB Hitch installation can be made easier with a cutter type drill bit.

SV Trimming or removal of under body appearance panel may be required.

TA Trunk access required for hitch installation.

TW Receiver hitch may limit hands-free liftgate sensor range

X Minor fascia trimming required.

T-ONE					TOW HARNESS					4-FLAT WIRING				REQ. 4 FLAT WIRING		7-WAY HARDWARE	BRAKE CONTROL HARNESS	IN	
PC	T-ONE	FN	IN	AMP	CP	PC	TOW HARN	FN	IN	AMP	CP	TYPE	ELEC	POS	CHOICE 1				CHOICE 2
VOLKSWAGEN (Continued)																			
													BTT	PC3,4	119251	119191			
													BTT	PC3,4	119251	119191			
													B	PC3,4	119130	119178			
													B	PC3,4	119130	119178			
E22	118667	CH	45	4.2,7.5	X								BTT	PC3,4	119251	119191			
													B	PC3,4	119130	119178			
													B.E	PC3,4	119191	119148			
E27	118572	CH	45	4.2,7.5	X								B.E	PC3,4	119191	119148			
E27	118572	CH	45	4.2,7.5	X								B.E	PC3,4	119191	119148			
E22	118791	CH,NZ	45	5.7.5	X								B.E	PC3,4	119191	119148			
													B	PC3,4	119130	119178			
													B	PC3,4	119130	119178			
													B	PC3,4	119130	119178			
E25	118562	CH	45	4.2,7.5	X								BM	PC1,2	119251	119191			
E22	118530	CH	45	4.2,7.5	X								BM	PC1,2	119251	119191			
E20	118646		45	4.2,7.5	X								BTT	PC3,4	119251	119191			
E20	118721	CH	45		X								BTT	PC3,4	119251	119191			
E20	118742	CH	45	5.7.5	X								A.E	PC3,4					
E20	118721	CH	45		X								BTT	PC3,4	119251	119191			
													BTT	PC1,2	119251	119191			
E7	118490		20	7.5									A	SUV1,2	119148	20252	20320	20321	20224
													A	SUV1,2	119148	20252	20320	20321	20224
													BT	SUV1,2	119251	119191	20320	20321	
E20	118675	CH,BN	45	4.2,7.5	X								BTT	SUV1,2	119251	119191	20320	20321	20224
E17	118811		45	5.7.5	X								BTT	SUV1,2		119251			
E17	118811		45	5.7.5	X								N	SUV1,2		119251			
E17	118811		45	5.7.5	X								BTT	SUV3,4		119251			
E20	118675	CH,BN	45	4.2,7.5	X								BTT	SUV1,2	119251	119191	20320	20321	20224
E24	118509	CH	45	4.2,7.5	X								B.E	SUV3,4	119191	119148	20320	20321	20224
E18	118668	CH	45	4.2,7.5	X								BTT	SUV1,2	119192	119191	20320	20321	20224
VOLVO																			
													E	PC3,4	119191	119148			
													E	PC3,4	119191	119148			
													B.E	PC3,4	119191	119148			
													E	PC3,4	119191	119148			
													E	PC3,4	119191	119148			
													B.E	PC3,4	119191	119148			
													E	PC3,4	119191	119148			
E15	118770	CH	45	5.7.5	X								B.E	PC3,4	119191	119148	20320	20321	
													E	PC3,4	119191	119148			
E19	118454	CH	45	2.1,5.6	X								B.E	PC3,4	119191	119148			
E14	118683	CH	20	4.2,7.5	X								B.E	SUV3,4					
													E	PC3,4	119191	119148			
E16	118647	CH	45	4.2,7.5	X								B.E	PC3,4	119191	119148			
													E	PC1,2	119191	119148			

A 2 wire system.
B 3 wire system. Converter required.
BM Multiplexed wiring system. ModuLite® HD Plus or Ultra required.
BN Exterior mounted plug on some or all models. May require an aftermarket electrical mounting box or bracket. (Sold separately)
BT Shared Brake/Tail multiplexed wiring system. ModuLite® HD Plus or Ultra required.
BTT Shared Brake/Tail/Turn multiplexed wiring system. ModuLite® HD Plus or Ultra required.
CH T-One is equipped with circuit protected ModuLite® module.
E ModuLite® required.
N DO NOT cut or splice vehicle wiring. Only use approved T-One or see auto dealer for trailer tow wiring kit.
NZ DO NOT use ZCI with this application. Please use other approved kit or contact dealer.

RT1 Round Tube Class I 1-1/4"
SQ1 Square Tube Class I
SQ2 Square Tube Class II
SQ3 Square Tube Class III
SQ4 Square Tube Class IV

T-ONE					TOW HARNESS					4-FLAT WIRING				REQ. 4 FLAT WIRING		7-WAY HARDWIRE	BRAKE CONTROL HARNESS	IN	
PC	T-ONE	FN	IN	AMP	CP	PC	TOW HARN	FN	IN	AMP	CP	TYPE	ELEC	POS	CHOICE 1				CHOICE 2
VOLVO (Continued)																			
													E	PC1,2	119191	119148			
													B,E	PC1,2	119191	119148			
E15	118463	CH	45	2,1,5,6	X								B,E	SUV3,4	119191	119148	20320	20321	20224
E15	118792	CH	45	5,7,5	X								B,E	SUV1,2	119191	119148			
E20	118523	CH	45	4,2,7,5	X								B,E	SUV3,4	119191	119148	20320	20321	20224
E20	118523	CH	45	4,2,7,5	X								B,E	SUV3,4	119191	119148	20320	20321	20224
													B,E	SUV3,4	119191	119148	20320	20321	20224
E16	118773	CH	45	5,7,5	X								B,E	SUV3,4	119191	119148			
													B,E	PC1,2	119191	119148			
E17	118774	CH	45	5,7,5	X								B,E	SUV3,4	119191	119148	20320	20321	20224
													B,E	SUV3,4	119191	119148	20320	20321	20224
E18	118411	CH	20	2,1,5,6	X								B,E	SUV3,4	119191	119148	20320	20321	20224
E14	118683	CH	20	4,2,7,5	X								B,E	SUV3,4	119191	119148	20320	20321	20224

B 3 wire system. Converter required.
CH T-One is equipped with circuit protected ModuLite® module.

E ModuLite® required.

SQ2 Square Tube Class II
SQ3 Square Tube Class III
SQ4 Square Tube Class IV

ELECTRICAL POSITIONS

PASSENGER CARS (PC)

Passenger car wiring positions are referenced by the letters PC and a number. Use the illustration to identify the wiring location for all passenger cars.

- PC1** - Behind driver side taillight - externally
- PC2** - Behind passenger side taillight - externally
- PC3** - Inside trunk behind driver side taillight - internally
- PC4** - Inside trunk behind passenger side taillight - internally
- PC5** - Under vehicle, driver side
- PC6** - Under vehicle, center
- PC7** - Under vehicle, passenger side



PICKUP TRUCKS, FULL & MID-SIZE (PU)

Pickup truck wiring positions are referenced by the letters PU and a number. Use the illustration to identify the wiring location for all trucks.

- PU1** - Behind driver side taillight
- PU2** - Behind passenger side taillight
- PU3** - Under vehicle, driver side
- PU4** - Under vehicle, passenger side
- PU5** - Under vehicle, center



SPORT UTILITY, VAN & MINI-VANS (SUV)

Sport utility, vans & mini-van wiring positions are referenced by the letters SUV and a number. Use the illustration to identify the wiring location for all sport utility vehicles, vans and mini-vans.

- SUV1** - Behind driver side taillight
- SUV2** - Behind passenger side taillight
- SUV3** - Behind driver side trim panel
- SUV4** - Behind passenger side trim panel
- SUV5** - Under vehicle, driver side
- SUV6** - Under vehicle, center
- SUV7** - Under vehicle, passenger side
- SUV8** - Inside vehicle, center
- SUV9** - Inside vehicle, passenger side, behind panel near rear seat

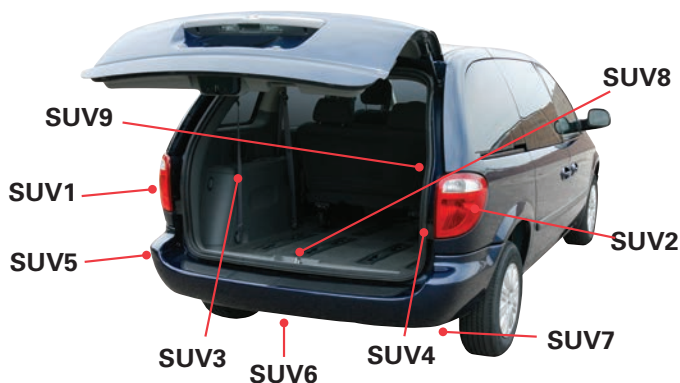

ELECTRICAL APPLICATION FOOTNOTES	
A	2 wire system.
B	3 wire system. Converter required.
BM	Multiplexed wiring system. ModuLite® HD Plus or Ultra required.
BN	Exterior mounted plug on some or all models. May require an aftermarket electrical mounting box or bracket. (Sold separately)
BT	Shared Brake/Tail multiplexed wiring system. ModuLite® HD Plus or Ultra required.
BTT	Shared Brake/Tail/Turn multiplexed wiring system. ModuLite® HD Plus or Ultra required.
C	2 or 3 wire system determine at installation.
CE	T-One includes fuse(s) & relay(s). Converter not required. Standard 2 wire system at factory tow plug.
CG	T-One incorporates circuit protected taillight converter.
CH	T-One is equipped with circuit protected ModuLite® module.
D	See auto dealer for trailer tow wiring kit.
E	ModuLite® required.
FV	2003 Models w/Build date after 11/1/02.
FW	2003 Models w/Build date before 11/1/02.
G	Low-side switching system.
H	3 wire system with OEM standard 2 wire harness.
HG	T-One incorporates taillight converter.
HJ	Per Dodge owner's manual: If trailer is equipped with more than standard lighting (1 taillight per side) use of ModuLite® or dealer supplied harness is required.
JM	Some early production 1994 models may require #118348.
LS	T-One incorporates low-side switching taillight converter. Additional installation time required.
M	Will fit with heavy-duty suspension.
N	DO NOT cut or splice vehicle wiring. Only use approved T-One or see auto dealer for trailer tow wiring kit.
NZ	DO NOT use ZCI with this application. Please use other approved kit or contact dealer.
QP	Will not fit vehicles with backup sensors built into rear bumper.
RD	For vehicles equipped with factory tow package may require additional components or may be used as a replacement harness.
RW	On some models it may require an upgraded flasher or ModuLite®.
TR	Trimming or Modification of the vehicle connector may be required.
Z	May be equipped with Factory Tow Prep Plug. Determine at time of installation.
HITCH APPLICATION FOOTNOTES	
#	Titan hitches require use of a 2-1/2" shank Titan ball mount.
@	Ultra Frame ball mount must be used to achieve maximum weight carrying rating.
†	Available while supply lasts.
AA	Requires temporary removal of bumper during installation.
AB	Requires four (4) 3/8 in. spacer blocks (#01077011) for installation. (Sold separately)
AE	Requires temporary removal of muffler during installation.
AF	Hitch is ONLY rated for Weight Carrying at 3500 lbs. GTW / 350 lbs. TW and DO NOT use Weight Distribution Spring Bars for this Specific Vehicle. Except for long bed pickups.
AG	Drawbar Kit & Accessory Adapter sold separately.
AI	Additional installation time may be required.
AL	Additional installation time required for vehicles equipped with load leveling compressor.
AW	Will not fit Turbo models.
BF	Requires standard bumper. Will not fit with step bumper.
BN	Exterior mounted plug on some or all models. May require an aftermarket electrical mounting box or bracket. (Sold separately)
BY	Minor repositioning of muffler required.
CA	Models with dual exhaust require exhaust modification.
CC	Requires minimum of 19 in. from end of frame rail to spring shackle bracket.
CH	T-One is equipped with circuit protected ModuLite® module.
CN	Requires OEM factory bumper for hitch installation.
CO	Will not fit 8 ft. 2500/3500 Series with heavy-duty suspension or four door Crew Cab.
CP	Fits all models without factory installed receiver.
CQ	Will not fit with heavy duty suspension.
CR	Fits with mini spare tire stowed under vehicle. Will not fit with full size spare.
CS	Will fit with full-size spare tire stowed under vehicle.

RECEIVER HITCH APPLICATION FOOTNOTES

HITCH APPLICATION FOOTNOTES (Continued)

CS	Will fit with full-size spare tire stowed under vehicle.
CT	Will not fit long bed models after 1999.
DA	Will not fit with tube style bumper.
DB	Will not fit 6 ft. bed pickups.
DH	Cannot be installed on 1987-97 vehicles with factory step bumpers unless step bumper and its mounting brackets are permanently removed and standard factory bumper is installed.
DS	Use DT #75151 On 1500 Models Built After 11/1/02. Use DT #75135 On 1500 Models Built Before 11/1/02.
DU	Fascia removal required.
DY	Use On 1500 Models Built After 11/1/02.
EB	Factory electrical bracket will NOT fit with this hitch. Must use aftermarket electrical box or bracket.
EF	Fits all models with standard bumpers.
EG	Relocation of spare tire bracket is not required. NOTE: 19mm open end style wrench must be purchased to allow removal of spare tire after hitch installation.
EO	Requires longer ball mount.
EP	Fascia trimming may be required.
FE	Fascia trimming may be required. Allow additional installation time.
FP	Spare tire repositioning and/or modification of spare tire carrier may be required.
FS	Includes 2 & 4 WD models with heavy duty suspension.
GH	Will not fit models with 34 in. wide frames.
GO	Requires hitch with packaging date code 2/15/94 or later.
GP	Hitch crosstube concealed behind bumper.
GU	Will not fit vehicles with factory or aftermarket lower Fascia/Rollpan or Tube Bumper.
GX	Requires fabrication of L-bracket to reposition exhaust on 1995 and later 6 ft. box models.
HA	External dress panel beneath 95-97 and 03-05 vehicles must be removed for hitch installation.
HB	Slight fascia deformation may occur on some models.
HC	Will not fit with mini or full size tire stowed under vehicle.
HD	Will not fit 6 ft. bed pickups except 6 ft. Super Cab.
HK	Under vehicle spare tire stowage may be retained with installation of an aftermarket spare tire repositioner. Cutting of rollpan in license plate area required for receiver tube access. Does not fit with bumper.
HM	Hitch crosstube is visible beneath bumper.
HP	Requires four (4) 7/16 in. x 1 in. x 2 in. spacer blocks (#01080012) for installation. (Sold separately)
HR	Requires drilling of heat shields on V6 models.
HX	Minor exhaust modification may be required.
HY	Ultra Frame ball mount DT #4283/HH #80125 cannot be used in rise position on vehicles with step bumpers.
I	Hitch is positioned further rearward to accommodate spare tire.
J	Under vehicle spare tire stowage is retained.
JF	Will not fit with 16 in. spare tire.
JL	Installation requires OEM bumper and brackets.
JR	Exhaust must be temporarily lowered for installation.
JV	Rubber air deflector/fascia must be removed or trimmed to install hitch.
K	Adapter kit (#1685) required with DT #41504/HH #87480/RS #37081 & RS #44143 for 1980 and later F-Series pickups.
KA	Gasoline engine models only.
KH	Minor heat shield modification may be required.
KK	When installing on a vehicle originally equipped with an OEM hitch. OEM bumper brackets must be purchased and installed prior to new hitch installation.
KL	Hitch is designed to attach beneath the OEM hitch.
KM	Does not work with models originally equipped with OEM hitch.
L	Exhaust repositioning required.
LT	Requires removal of factory hitch if equipped.
M	Will fit with heavy-duty suspension.
MB	Will not fit models equipped with air suspension package.
QW	Will not fit vehicles with dual exhaust.
RA	Do not install on early 1996 models equipped with M10 fasteners.
RB	Hitch installation can be made easier with a cutter type drill bit.
RC	Will not fit with rear sport bars.
RH	Optional drawbar #36051 required (Sold separately) except for models with ZR2 & Highrider package.

HITCH APPLICATION FOOTNOTES (Continued)	
RO	Will not fit Silverado SS.
SA	Requires drilling on 6 ft. bed models.
SB	Will not fit models with short bed.
SC	Minor trimming of plastic trunk pan required.
SD	Hitches produced before 07/21/06 are rated at 350/3500 WC.
SG	Hitches produced before 09/10/07 are rated at 1000/10000 WC & 1200/12000 WD.
SH	Hitches produced before 09/27/07 are rated at 1200/12000 WC & 1400/14000 WD.
SI	Hitches produced before 07/31/07 are rated at 350/3500 WC & 500/5000 WD.
SN	Hitches produced before 04/28/08 are rated at 1000/10000 WC & 1200/12000 WD.
SO	With this hitch installed the step bumper is no longer able to be used as a towing point.
SR	Only use ball mounts with 8-1/2 in. length : 3/4 in. rise : 2 in. drop for this vehicle.
ST	Will not fit 2WD models with short bed.
SU	Hitches produced before 03/11/08 are rated at 1000/10000 WC & 1200/12000 WD.
SV	Trimming or removal of under body appearance panel may be required.
SY	Hitch crosstube is visible beneath bumper with a more than normal gap between fascia and crosstube.
SZ	Hitches produced before 03/10/11 are rated at 600/6000 WC.
TA	Trunk access required for hitch installation.
TD	Hitches without electrical bracket are rated at 350/3500 WC & No WD. Hitch with electrical bracket rated at 400/4000 WC & No WD.
TE	Hitches produced before 04/20/11 are rated at 500/5000 WC.
TG	Hitches produced before 05/13/11 are rated at 350/3500 WC.
TI	Hitches produced before 06/06/11 are rated at 400/4000 WC.
TJ	Hitches produced before 07/13/11 are rated at 350/3500 WC.
TK	Hitches produced before 09/09/11 are rated at 500/5000 WC & 600/6000 WD.
TL	Hitches produced before 10/31/11 are rated at 500/5000 WC & 750/7500 WD.
TM	Hitches produced before 01/04/12 are rated at 500/5000 WC & 750/7500 WD.
TN	Hitches produced before 07/09/12 are rated at 500/5000 WC & 500/5000 WD.
TO	Will not fit models equipped Chassis Cab spring mount.
TQ	Hitches produced before 07/30/12 are rated at 350/3500 WC.
TU	Hitches produced before 07/24/12 are rated at 350/3500 WC.
TW	Receiver hitch may limit hands-free liftgate sensor range
TZ	Requires replacement of the impact structure with hitch.
UD	Fascia removal required on XR & XRS models.
UL	This hitch will not fit a Sprinter single or dual rear-wheel vehicle with a 30-3/8 in. wide frame measured outside of frame to outside of frame.
V	For vehicles with factory installed step bumpers only.
VB	Will not fit vehicles with vibration damper installed at rear of frame on drivers side.
X	Minor fascia trimming required.



36010†

MOTORHOME CLASS III HITCH

LAST CHANCE

Part Number	Description	Substitute Part Number	Packaging	Master Carton
36010†	Motorhome Hitch, Adjusts up to 46" Wide, 500/5,000 (GTW/TW)	5350	Boxed	1



58374†

ULTRA FRAME HITCH END CAPS

LAST CHANCE

Part Number	Description	Substitute Part Number	Packaging	Master Carton
58374†	Ultra Frame Hitch End Caps	-	Boxed	1



808018†

COMBO BAR

LAST CHANCE

Part Number	Description	Substitute Part Number	Packaging	Master Carton
808018†	Combo Bar, 18" Length	2898	Boxed	1

† = Available while supplies last



HITCH ACCESSORIES

Draw-Tite® has been designing and manufacturing the world's finest trailering products since 1946. That's why it makes sense to use genuine Draw-Tite® Ball Mounts and Hitch Balls to ensure the integrity of your tow vehicle's rig. Draw-Tite® components are designed and manufactured to work best with other Draw-Tite® products, and all are engineered to the same exacting standards for years of worry-free performance under the most demanding conditions.

HITCH BALLS

Hitch Ball Selection	B-3
1-7/8 in. Hitch Balls	B-3
2 in. Hitch Balls	B-4
2-5/16 in. Hitch Balls	B-4
Interchangeable Hitch Balls	B-5
50mm Hitch Balls	B-5
Marine Hitch Balls	B-5

BALL MOUNTS

Ball Mount Selection	B-6
Class I and II Drawbars	B-7
Class III and IV Ball Mounts	B-8 - B-10
Marine Ball Mounts	B-9
Towing Starter Kits	B-9
Aluminum Ball Mounts	B-9 - B-10
Class V Ball Mounts	B-11
Dual and Tri Ball Mounts	B-11 - B-13
Adjustable Ball Mounts	B-13 - B-14

PINTLE HOOKS

Pintle Hook Mounts	B-17
Adjustable Pintle Mounts	B-17
Pintle Hooks	B-18
Pintle Hook Combinations	B-18
Lunette Rings	B-18
Receiver Mount Pintle Hooks	B-19
Receiver Mount Tow Hooks and Rings	B-19
Clevis Mounts	B-20

HITCH ACCESSORIES

Reducer Sleeves and Adapters	B-15
Receiver Extensions	B-16
Pins and Clips	B-20
Anti-Rattle Systems	B-21
Locks	B-22 - B-23
Hitch Ball Accessories	B-24
Receiver Tube Covers	B-24

DISCONTINUED PRODUCTS B-25 - B-30

NEW



FULTON® MARINE BALL MOUNTS

- Solid one-piece forged aluminum construction resists rust and corrosion
- 1 in. thick x 3 in. wide ball platforms
- Fits 2 in. square receiver tube opening
- Designed for marine use
- 8,000 lbs. capacity
- See page B-9 for additional information

FEATURED

CLASS V 3 IN. BALL MOUNTS

- Fits 3 in. square receiver tube opening
- 21,000 lbs. towing capacity
- Solid forged steel
- Metalshield™ finish
- See page B-11 for additional information



ADJUSTABLE BALL MOUNTS

The adjustable mount takes only a pull of the pin and a turn to get ready for towing with the most common hitch ball sizes. Just like you, it's always ready to get the job done.

- Height adjusts easily and securely with pins included
- Fits 2 in. receivers, rated up to 14,000 lbs. GTW
- Adjust height up to 10.5 in.
- Adjustable cast shank
- Knurled bolt pin with secure lanyard
- See page B-13 for additional information

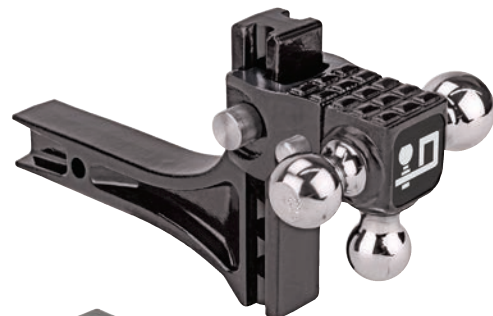

ADJUSTABLE PINTLE MOUNT

Tackle rough terrain with the toughest mount in. Adjustable for trailers of various heights and couplers. Converts quickly for a day of hassle-free towing.

- Fits 2 in. receivers, rated up to 14,000 lbs. GTW
- Adjust height up to 10-1/2 in.
- Adjustable cast shank, knurled bolt pin
- Black powder coat finish over E-coat
- See page B-17 for additional information



SELECTING THE RIGHT HITCH BALL:

1. Always use the properly-rated hitch ball for your towing system
2. Your towing system's maximum weight rating is always equal to the lowest rated item in the system
3. Your hitching system cannot be upgraded to a rating higher than the maximum rating of your hitch

For example, a 3,500 lbs. ball on a 2,000 lbs. max trailer weight-rated hitch does not increase your towing capacity to 3,500 lbs. Your hitching system is still rated at 2,000 lbs.

- Conversely, a 2,000 lbs. ball on a 3,500 lbs. max trailer weight-rated hitch decreases your maximum towing capacity to 2,000 lbs
- The hitch ball diameter (A) must be the same diameter as the trailer coupler (1-7/8, 2 or 2-5/16 in.)
- The shank diameter (B) of the hitch ball should be the same as the hole diameter in the ball mount
- The shank length (C) should be long enough to allow at least two threads to be visible when the hitch ball is installed and the nut completely tightened

*The ball diameter required is stamped into the coupler handle or body

**During hitch ball installation, torque all 3/4 in. shank diameter balls to 160 ft. lbs., and 1 in. shank diameter balls to 250 ft. lbs., and 1-1/4 in. shank diameter balls to 450 ft. lbs.

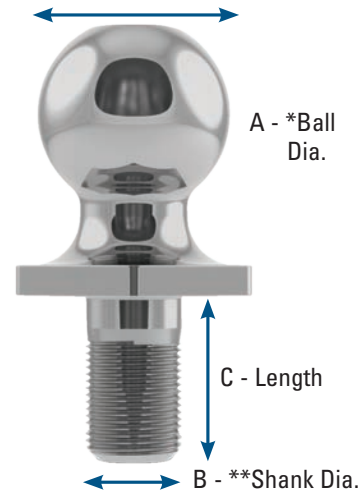

Chrome



Stainless Steel

1-7/8 IN. STANDARD HITCH BALLS

- Solid steel hitch balls engineered to meet all safety requirements of SAE J684
- Forged for superior strength
- Chrome or stainless steel finish for corrosion prevention and lasting good looks
- When installing hitch balls, torque
 - all 3/4 in. shank diameter balls to 160 ft. lbs.
 - all 1 in. shank diameter balls to 250 ft. lbs.
 - all 1-1/4 in. shank diameter balls to 450 ft. lbs.



Part Number	Finish	A Ball Diameter (in.)	B Shank Diameter (in.)	C Shank Length (in.)	Drawbar Thickness (in.)	Capacity (lbs.)	Packaging	Master Carton
63810	Chrome	1-7/8	3/4	1-1/2	3/8 - 5/8	2,000	Plastic Shroud	12
63812	Chrome	1-7/8	3/4	2-3/8	3/8 - 1-3/8	2,000	Plastic Shroud	12
63814	Chrome	1-7/8	3/4	3-3/8	3/8 - 2-1/8	2,000	Plastic Shroud	12
63816	Chrome	1-7/8	1	2-1/8	3/8 - 3/4	2,000	Plastic Shroud	12
63880	Chrome	1-7/8	3/4	1-1/2	3/8 - 5/8	2,000	Plastic Shroud	3
63882	Chrome	1-7/8	3/4	2-3/8	3/8 - 1-3/8	2,000	Plastic Shroud	3
63884	Chrome	1-7/8	1	2-1/8	3/8 - 3/4	2,000	Plastic Shroud	3
63851	Stainless Steel	1-7/8	1	2-1/8	3/8 - 3/4	2,000	Plastic Shroud	3



Chrome



Stainless Steel

2 IN. STANDARD HITCH BALLS

- Solid steel hitch balls engineered to meet all safety requirements of SAE J684
- Forged for superior strength
- Chrome or stainless steel finish for corrosion prevention and lasting good looks
- When installing hitch balls, torque
all 3/4 in. shank diameter balls to 160 ft. lbs.
all 1 in. shank diameter balls to 250 ft. lbs.
all 1-1/4 in. shank diameter balls to 450 ft. lbs.



Part Number	Finish	A Ball Diameter (in.)	B Shank Diameter (in.)	C Shank Length (in.)	Drawbar Thickness (in.)	Capacity (lbs.)	Packaging	Master Carton
63820	Chrome	2	3/4	1-1/2	3/8 - 5/8	3,500	Display Label	12
63822	Chrome	2	3/4	2-3/8	3/8 - 1-3/8	3,500	Display Label	12
63824	Chrome	2	3/4	3-3/8	3/8 - 2-1/8	3,500	Display Label	12
63845	Chrome	2	1	2-1/8	3/8 - 3/4	7,500	Display Label	12
63849	Chrome	2	1	3-1/4	3/8 - 2-1/8	7,500	Display Label	12
63830	Chrome	2	1-1/4	2-3/4	3/8 - 1	8,000	Display Label	12
63887	Chrome	2	3/4	1-1/2	3/8 - 5/8	3,500	Plastic Shroud	3
63889	Chrome	2	3/4	2-3/8	3/8 - 1-3/8	3,500	Plastic Shroud	3
63909	Chrome	2	1	2-1/8	3/8 - 3/4	7,500	Plastic Shroud	3
63899	Chrome	2	1-1/4	2-3/4	3/8 - 1	8,000	Plastic Shroud	3
63852	Stainless Steel	2	1	2-1/8	3/8 - 3/4	6,000	Plastic Shroud	3



Chrome



Stainless Steel

2-5/16 IN. STANDARD HITCH BALLS

- Solid steel hitch balls engineered to meet all safety requirements of SAE J684
- Forged for superior strength
- Chrome or stainless steel finish for corrosion prevention and lasting good looks
- When installing hitch balls, torque
all 3/4 in. shank diameter balls to 160 ft. lbs.
all 1 in. shank diameter balls to 250 ft. lbs.
all 1-1/4 in. shank diameter balls to 450 ft. lbs.



Part Number	Finish	A Ball Diameter (in.)	B Shank Diameter (in.)	C Shank Length (in.)	Drawbar Thickness (in.)	Capacity (lbs.)	Packaging	Master Carton
63847	Chrome	2-5/16	1	2-1/8	3/8 - 3/4	7,500	Display Label	6
63834	Chrome	2-5/16	1-1/4	2-3/4	3/8 - 1	12,000	Display Label	6
63836#	Chrome	2-5/16	1-1/4	2-3/4	3/8 - 1	14,000	Display Label	6
63840#	Chrome	2-5/16	1-1/4	2-3/4	3/8 - 1	20,000	Display Label	6
63908	Chrome	2-5/16	1	2-1/8	3/8 - 3/4	7,500	Plastic Shroud	3
63896	Chrome	2-5/16	1-1/4	2-3/4	3/8 - 1	12,000	Plastic Shroud	3
63864	Chrome	2-5/16	1-1/4	2-1/2	-	25,000	Display Label	6
63853	Stainless Steel	2-5/16	1	2-1/8	3/8 - 3/4	6,000	Plastic Shroud	3

Hitch ball requires use with like rated receiver and ball mount. Consult tow vehicle owners manual for maximum towing capacities.



50MM (1,600KG) HITCH BALL

- Solid steel hitch balls engineered to meet all safety requirements of SAE J684
- Forged for superior strength
- Castle nut and cotter pin included
- Torque to 160 ft. lbs.
- Chrome finish for corrosion prevention and lasting good looks



Part Number	Finish	Ball Diameter (in.)	Shank Diameter (in.)	Shank Length (in.)	Drawbar Thickness (in.)	Capacity (lbs.)	Packaging	Master Carton
63912	Chrome	50mm	3/4	1-1/2	3/8 - 5/8	3,500	Display Label	12



INTERCHANGEABLE HITCH BALL SYSTEM

Designed to accommodate towing multiple trailers with ease, the Interchangeable Hitch Ball System allows you to change hitch ball sizes in seconds without any tools. Available in 2- and 3-ball sets, these kits feature a quick-release, positive-latch design. Innovative quick release changes balls in seconds.

- Rated capacities up to 8,000 lbs.
- Durable heat-treated shank
- Positive latch design
- No special tools required
- Chrome finish for corrosion prevention and lasting good looks



Part Number	Finish	Shank Diameter (in.)	Capacity (lbs.)	Hitch Ball Diameters (in.)	Packaging	Master Carton
63802	Chrome	1	8,000	1-7/8 and 2	Clamshell	2
63803	Chrome	1	8,000	1-7/8, 2 and 2-5/16	Clamshell	2



FULTON® MARINE HITCH BALL

Designed for marine use, Fulton® brand hitch balls are time-tested and application-proven. A durable stainless steel finish keeps your hitch ball corrosion free. Ships complete with lock washer and nut. Solid steel hitch balls engineered to meet all safety requirements of SAE J684.

- Stainless steel finish for corrosion prevention and lasting good looks



Part Number	Finish	Ball Diameter (in.)	Shank Diameter (in.)	Shank Length (in.)	Drawbar Thickness (in.)	Capacity (lbs.)	Packaging	Master Carton
6385288	Stainless	2	1	2-1/8	3/8 - 3/4	6,000	Plastic Shroud	3

BALL MOUNTS

There is a Draw-Tite® ball mount for just about every application; from lightweight Class I hitches to heavy-duty Class V workhorse products. In addition, Draw-Tite® manufactures a number of specialty ball mounts for unique applications like leveling your trailer and converting a ball mount to a pintle hook. A wide range of accessories are also available to enable you to custom-equip your rig to your unique needs.

Choose from Class I- Class V conventional ball mounts with rise or drop styles and multiple lengths to meet your hitching needs. Draw-Tite's Towing Starter Kit contains everything you need to get underway with your trailer. A wide range of specialty hitches enable a quick conversion to other ball sizes and other hitching options. A range of accessories makes your trailering experience easier and more convenient. Make Draw-Tite® ball mounts your first and only choice in meeting your towing needs.

SELECTING THE RIGHT BALL MOUNT:

1. Measure from the ground to the top of the hitch
2. Measure from the ground to the (inside) top of the trailer coupler (when level)
3. Subtract the height of the hitch ball from coupler measurement, (most are 2-1/2 in. - 3 in. high)
4. An 8 in. drop is needed to make their trailer level

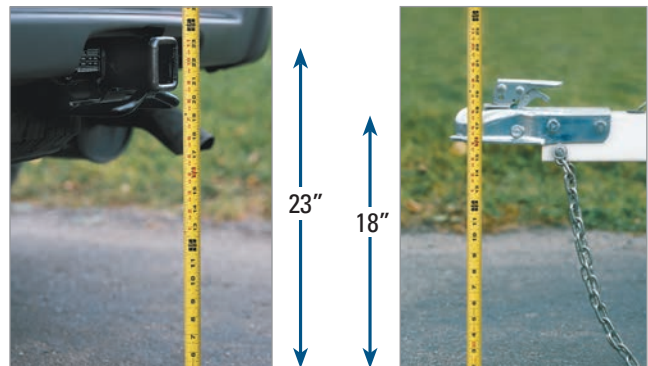

(Example: 23 in. - 18 in. = 8 in. drop)

The difference in the two measurements is the amount of ball mount (A) - "rise" or (B) - "drop" required.

Length
Distance from the center of the ball hole to the center of the pin hole

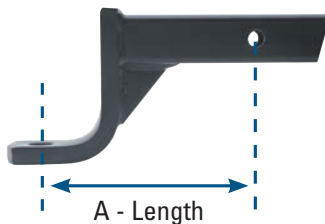

Rise
Distance from the top of the shank to the top of the ball platform

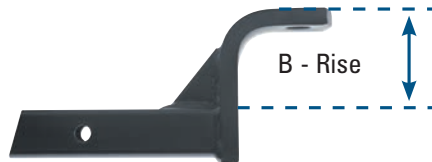

Drop
Distance from the top of the shank to the top of the ball platform

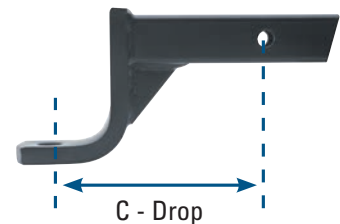

BALL MOUNT STYLES:

We offer ball mounts in three separate styles; straight cut, angle cut and drop cut. Refer to the styles below to select the mount that best suits your needs.

Style 1 - Straight Cut



Style 2 - Angle Cut



Style 3 - Drop Cut





3590



3594



36063



36071



28451

CLASS I DRAWBAR KITS

- Boxed includes drawbar, pin and clip
- Fits 1-1/4 in. square receiver tube opening
- Black powder coat finish over E-coat

Part Number	Rating GTW/TW (lbs.)	Ball Hole Size (in.)	A Length (in.)	B Rise (in.)	C Drop (in.)	Style	Packaging	Master Carton
3590	2,000/200	3/4	6-5/8	5/8	-	1	Display Label	1
3591	2,000/200	3/4	9-3/4	5/8	-	1	Display Label	1
3592	2,000/200	3/4	9-3/4	2-1/8	2-3/4	3	Display Label	1
3593	2,000/200	3/4	6-5/8	2-1/8	2-3/4	3	Display Label	1
3594	2,000/200	3/4	10	4	-	2	Display Label	1

NOTE: Class I drawbar applications are specific. The correct replacement drawbar part number is listed on each Class I hitch installation instruction sheet.

CLASS II DRAWBAR KITS

- Boxed includes drawbar, pin and clip
- Fits 1-1/4 in. square receiver tube opening
- Black powder coat finish over E-coat

Part Number	Rating GTW/TW (lbs.)	Ball Hole Size (in.)	A Length (in.)	B Rise (in.)	C Drop (in.)	Style	Packaging	Master Carton
36051	3,500/300	3/4	7	5/8	1-1/4	1	Display Label	1
36053	3,500/300	3/4	9-3/4	5/8	1-1/4	1	Display Label	1
36061	3,500/300	3/4	9-3/4	3-1/8	-	2	Display Label	1
36063	3,500/300	3/4	11-3/4	3-1/8	-	2	Display Label	1
36065	3,500/300	3/4	10	5	-	2	Display Label	1
36071	3,500/300	3/4	7-3/16	2-5/8	3-1/4	3	Display Label	1
36078*	3,500/300	3/4	7-3/8	-	4-3/4	3	Display Label	1

** Fits 1-1/4 in. OEM Ford Explorer, Lincoln Aviator and Mercury Mountaineer hitch*

NOTE: Class II drawbar applications are specific. The correct replacement drawbar part number is listed on each Class II hitch installation instruction sheet.

INVISI-HITCH™ DRAWBAR KIT

- Boxed includes drawbar, pin and clip
- Fits 1-1/4 in. square receiver tube opening
- Black powder coat finish over E-coat

Part Number	Rating GTW/TW (lbs.)	Ball Hole Size (in.)	A Length (in.)	B Rise (in.)	C Drop (in.)	Style	Packaging	Master Carton
28451	2,000/200	3/4	10-5/8	3-1/2	-	2	Display Label	1

2953



CLASS III/IV MAX FRAME MOUNT KITS

- Includes pin and clip
- Fits 2 in. square receiver tube opening
- Black powder coat finish over E-coat

Part Number	Rating GTW/TW (lbs.)	Ball Hole Size (in.)	A Length (in.)	B Rise (in.)	C Drop (in.)	Style	Packaging	Master Carton
2923	7,500/750	1	8-1/2	3/4	2	2	Display Label	1
2953	7,500/750	1	9	2-3/4	4	3	Display Label	1

40342



EASY LOAD BALL MOUNTS

- Featuring a revolutionary tapered shank design
- Easy-load ball mounts provide an easy connection to the receiver
- Fits 2 in. square receiver tube opening
- Black powder coat finish over E-coat

Part Number	Rating GTW/TW (lbs.)	Ball Hole Size (in.)	A Length (in.)	B Rise (in.)	C Drop (in.)	Style	Packaging	Master Carton
40342	7,500/750	1	8-1/2	3/4	2	2	Display Label	6
40343	6,000/600	1	10-1/2	3/4	2	2	Display Label	6
40344	7,500/750	1	9	2-3/4	4	2	Display Label	6
40345	6,000/600	1	11	2-3/4	4	2	Display Label	6
40346	7,500/750	1	9-1/2	4-3/4	6	2	Display Label	2

40344



2706



UTILITY BALL MOUNTS

- Pin and clip sold separately
- Fits 2 in. square receiver tube opening
- Black powder coat finish over E-coat

Part Number	Rating GTW/TW (lbs.)	Ball Hole Size (in.)	A Length (in.)	B Rise (in.)	C Drop (in.)	Style	Packaging	Master Carton
2736	5,000/500	1	12	3/4	2	1	Display Label	1
2793	5,000/500	1	10	6-3/4	8	3	Display Label	1
2706	5,000/500 3,500/350	1	9 9	- 9-3/4	11 -	3	Display Label	2



40238-002



PDQ Tray

STANDARD TOWING STARTER KITS

- Point of purchase retail display
- Includes pin and clip
- Fits 2 in. square receiver tube opening
- Black powder coat finish over E-coat (except 40584-002 with chrome ball mount)

Part Number	Rating GTW/TW (lbs.)	Ball Hole Size (in.)	A Length (in.)	B Drop (in.)	Ball Size (in.)	Style	Packaging	Master Carton
83407-002	2,000/200	1	8-1/2	2	1-7/8	2	PDQ Tray (2 Pack)	1
40058-002	7,500/750	1	8-1/2	2	2-5/16	2	PDQ Tray (2 Pack)	1
40238-002	7,500/750	1	9	4	2-5/16"	2	PDQ Tray (2 Pack)	1
40583-002	7,500/750	1	8-1/2	2	2	2	PDQ Tray (2 Pack)	1
40644-002	7,500/750	1	9	4	2	2	PDQ Tray (2 Pack)	1



40565

INTERLOCK® TOWING STARTER KIT

- Includes 2 in. hitch ball
- Includes receiver lock
- Fits 2 in. square receiver tube opening
- Black powder coat finish over E-coat

Part Number	Rating GTW/TW (lbs.)	Ball Hole Size (in.)	A Length (in.)	B Rise (in.)	C Drop (in.)	Style	Packaging	Master Carton
40565	6,000/600	1	8-1/2	3/4	2	2	Plastic Case	2



40382

FULTON® MARINE BALL MOUNTS

- Solid one-piece forged construction resists rust and corrosion
- 1 in. thick x 3 in. wide ball platforms
- Fits 2 in. square receiver tube opening
- Aluminum finish

Part Number	Rating GTW/TW (lbs.)	Length (in.)	Rise (in.)	Drop (in.)	Packaging	Master Carton
4038188	8,000/800	9-7/8	1	2	Display Label	2
4038288	8,000/800	10-5/8	3	4	Display Label	2
4038388	8,000/800	11-7/8	5	6	Display Label	2

40331



SOLID FORGED BALL MOUNTS

- Solid one-piece forged construction
- 1 in. thick x 3 in. wide ball platforms
- Angled, easy-load design
- Fits 2 in. square receiver tube opening
- Black powder coat finish over E-coat

Part Number	Rating GTW/TW (lbs.)	Ball Hole Size (in.)	A Length (in.)	B Rise (in.)	C Drop (in.)	Style	Packaging	Master Carton
40330	16,000/2,400	1-1/4	8-1/2	1	2	-	Display Label	2
40331	16,000/2,400	1-1/4	9-1/4	3	4	-	Display Label	2
40332	16,000/2,400	1-1/4	10-1/4	5	6	-	Display Label	2

40382



ALUMINUM SOLID FORGED BALL MOUNTS

- Solid one-piece forged construction
- 1 in. thick x 3 in. wide ball platforms
- Fits 2 in. square receiver tube opening
- Aluminum finish

Part Number	Rating GTW/TW (lbs.)	Ball Hole Size (in.)	A Length (in.)	B Rise (in.)	C Drop (in.)	Style	Packaging	Master Carton
40381	8,000/800	1	9-7/8	1	2	-	Display Label	2
40382	8,000/800	1	10-5/8	3	4	-	Display Label	2
40383	8,000/800	1	11-7/8	5	6	-	Display Label	2
40384	6,000/600	1	10-7/8	7	8	-	Display Label	2

40201



HOLLOW SHANK BALL MOUNTS

- Fits 2 in. square receiver tube opening
- Black powder coat finish over E-coat

Part Number	Rating GTW/TW (lbs.)	Ball Hole Size (in.)	A Length (in.)	B Rise (in.)	C Drop (in.)	Style	Packaging	Master Carton
40200	10,000/1,000	1-1/4	8-1/2	3/4	2	1	Display Label	2
40201	10,000/1,000	1-1/4	9	2-3/4	4	3	Display Label	2
40202	10,000/1,000	1-1/4	11-1/4	2-3/4	4	3	Display Label	2
40205	10,000/1,000	1-1/4	9	-	6	3	Display Label	2
40206	10,000/1,000	1-1/4	9	-	8	3	Display Label	2

4285



HOLLOW SHANK BALL MOUNTS

- Fits 2 in. square receiver tube opening
- Durable zinc coated finish

Part Number	Rating GTW/TW (lbs.)	Ball Hole Size (in.)	A Length (in.)	B Rise (in.)	C Drop (in.)	Style	Packaging	Master Carton
4280	12,000/1,200	1-1/4	8-1/2	1	2	1	Display Label	1
4284	12,000/1,200	1-1/4	12	1	2	1	Display Label	1
4281	12,000/1,200	1-1/4	8-1/2	3	4	3	Display Label	1
4285	12,000/1,200	1-1/4	12	3	4	3	Display Label	1
4282	12,000/1,200	1-1/4	9-1/2	5	6	3	Display Label	1
4283	12,000/1,200	1-1/4	9-1/2	7	8	3	Display Label	1



45322

CLASS V 2-1/2 IN. BALL MOUNTS

- Fits 2-1/2 in. square receiver tube opening
- Black powder coat finish over E-coat

Part Number	Rating GTW/TW (lbs.)	Ball Hole Size (in.)	A Length (in.)	B Rise (in.)	C Drop (in.)	Style	Packaging	Master Carton
45122	14,000/1,400	1-1/4	9-3/4	1-1/2	3	3	Display Label	1
45123	13,000/1,300	1-1/4	10	3-1/2	5	3	Display Label	1
45291	13,000/1,300	1-1/4	10-1/2	-	7-3/4	3	Display Label	1
45322	18,000/2,000	1-1/4	10	1-1/2	3	3	Display Label	1
45323	18,000/2,000	1-1/4	10	3-1/2	5	3	Display Label	1



40701

CLASS V 3 IN. BALL MOUNTS

- Fits 3 in. square receiver tube opening
- Metalshield™ finish

Part Number	Rating GTW/TW (lbs.)	Ball Hole Size (in.)	A Length (in.)	B Rise (in.)	C Drop (in.)	Style	Packaging	Master Carton
40700	21,000/2,100	1-1/4	10-1/2	2	4	3	Display Label	1
40701	21,000/2,100	1-1/4	10-1/2	4	6	3	Display Label	1
40702	21,000/2,100	1-1/4	11-1/2	6	8	3	Display Label	1
40703	21,000/2,100	1-1/4	11-1/2	8	10	3	Display Label	1



38180

CLASS V DUAL-BALL MOUNT

- Fits 3 in. square receiver tube opening
- Black powder coat finish over E-coat

Part Number	Description	Rating GTW/TW (lbs.)	Length (in.)	Ball Size (in.)	Packaging	Master Carton
38180	Dual-Ball Mount	17,000/1,700 25,000/2,500	9	2 2-5/16	Display Label	1



45325

CLASS V TRI-BALL HOLLOW SHANK

- Fits 2-1/2 in. square receiver tube opening
- Black powder coat finish over E-coat

Part Number	Description	Rating GTW/TW (lbs.)	Length (in.)	Ball Size (in.)	Packaging	Master Carton
45325	Tri-Ball Hollow Shank	2,000/200 10,000/1,000 14,000/1,400	8-3/4 8-3/4 7-1/2	1-7/8 2 2-5/16	Display Label	1

80796



DUAL-BALL SOLID SHANKS

- Fits 2 in. square receiver tube opening
- Black powder coat finish over E-coat

Part Number	Description	Rating GTW/TW (lbs.)	Length (in.)	Ball Size (in.)	Packaging	Master Carton
80796	Dual-Ball Mount, Black Balls, Black Solid Shank	10,000/1,000 16,000/1,600	8 8	2 2-5/16	Display Label	2
80798	Dual-Ball Mount, Chrome Balls, Black Solid Shank	10,000/1,000 16,000/1,600	8 8	2 2-5/16	Display Label	2

80799



TRI-BALL SOLID SHANKS

- Fits 2 in. square receiver tube opening
- Black powder coat finish over E-coat

Part Number	Description	Rating GTW/TW (lbs.)	Length (in.)	Ball Size (in.)	Packaging	Master Carton
80791	Tri-Ball Mount, Black Balls, Black Solid Shank	2,000/200 10,000/1,000 16,000/1,600	8 8 6-3/4	1-7/8 2 2-5/16	Display Label	2
80799	Tri-Ball Mount, Chrome Balls, Black Solid Shank	2,000/200 10,000/1,000 16,000/1,600	8 8 6-3/4	1-7/8 2 2-5/16	Display Label	2

80406



DUAL-BALL HOLLOW SHANK

- Fits 2 in. square receiver tube opening
- Black powder coat finish over E-coat

Part Number	Description	Rating GTW/TW (lbs.)	Ball Size (in.)	Position	Packaging	Master Carton
80406	Dual-Ball Mount, Black Hollow Shank	6,000/600 6,000/600	2 2-5/16	Drop Rise	Display Label	1

80426



TRI-BALL HOLLOW SHANKS

- Fits 2 in. square receiver tube opening
- Black powder coat finish over E-coat

Part Number	Description	Rating GTW/TW (lbs.)	Length (in.)	Ball Size (in.)	Packaging	Master Carton
80425	Tri-Ball Mount, Black Balls, Black Hollow Shank	2,000/200 6,000/600 10,000/1,000	8 8 6-3/4	1-7/8 2 2-5/16	Display Label	2
80426	Dual-Ball Mount, Chrome Balls, Black Hollow Shank	2,000/200 6,000/600 10,000/1,000	8 8 6-3/4	1-7/8 2 2-5/16	Display Label	2

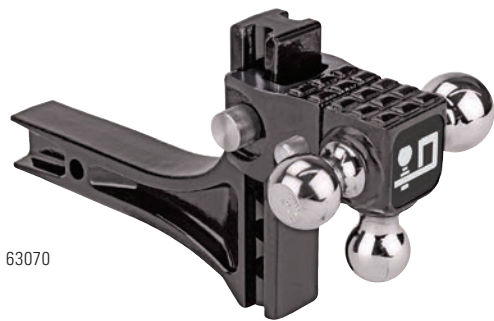

63070

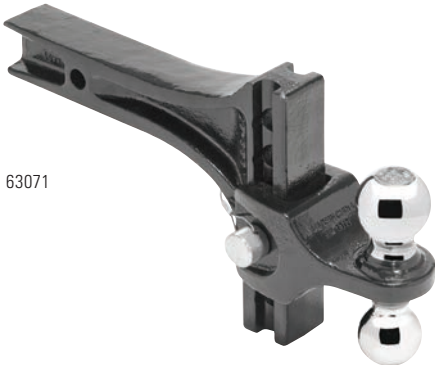

63071



63911

ADJUSTABLE BALL MOUNTS

The adjustable mount takes only a pull of the pin and a turn to get ready for towing with the most common hitch ball sizes. Just like you, it's always ready to get the job done.

- Height adjusts easily and securely with pins included
- Fits 2 in. receivers, rated up to 14,000 lbs. GTW
- Adjust height up to 10-1/2 in.
- Adjustable cast shank, knurled bolt pin with secure lanyard
- Black powder coat finish over E-coat

Part Number	Description	Length (in.)	Max Rise (in.)	Max Drop (in.)	Packaging	Master Carton
63070	Adjustable Tri-Ball Ball Mount System with Step and 2" Square Shank 1-7/8" Ball - 2,000 lbs. (GTW) 2" Ball - 10,000 lbs. (GTW) 2-5/16" Ball - 14,000 lbs. (GTW)	11-9/16	5-11/16	4-3/4	Litho Box	1
63071	Adjustable Dual-ball Mount System with 2" Square Shank 2" Ball - 10,000 lbs. (GTW) 2-5/16" Ball - 14,000 lbs. (GTW)	12	4-5/8	5-7/8	Litho Box	2
Accessory						
63069	Combo Lock Set for Adjustable Ball Mounts				Display Card	6
Replacement Part						
63911	Replacement Cast Shank				Boxed	1

ADJUSTABLE BALL MOUNT HEAD UNITS

- Adjustable dual-ball mount system head unit only
- Adjustable height - perfect for towing multiple trailers of varying heights and couplers
- Knurled bolt pins
- Black powder coat finish over E-coat



63075



63076

Part Number	Description	Packaging	Master Carton
63075	Adjustable Tri-Ball Ball Mount System with Step and 2" Square Shank, Head Unit Only 1-7/8" Ball - 2,000 lbs. (GTW) 2" Ball - 10,000 lbs. (GTW) 2-5/16" Ball - 14,000 lbs. (GTW)	Litho Box	1
63076	Adjustable Dual-ball Mount System with 2" Square Shank Head Unit Only 2" Ball - 10,000 lbs. (GTW) 2-5/16" Ball - 14,000 lbs. (GTW)	Litho Box	1



21141

ADJUSTABLE HOLLOW SHANK BALL MOUNT

- Fits 2 in. square receiver tube opening
- Quick release pin and clip for maximum adjustability
- Black powder coat finish over E-coat

Part Number	Description	Rating GTW/TW (lbs.)	Length (in.)	Max Rise (in.)	Max Drop (in.)	Packaging	Master Carton
21141	Complete Shank and Head Assembly with Quick Release Pin and Clip	5,000/500	13-1/2	6-1/4	7-1/2	Litho Box	1



7390

HOLLOW SHANK BALL MOUNT WITH SWAY CONTROL TAB

- Fits 2 in. square receiver tube opening
- Platform mounts for left or right hand sway control
- Black powder coat finish over E-coat

Part Number	Description	Rating GTW/TW (lbs.)	Length (in.)	Max Rise (in.)	Max Drop (in.)	Packaging	Master Carton
7390	Complete Shank and Head Assembly	6,000/600	12	3-3/4	5-1/4	Display Label	1

NOTE: Hitch ball, pin (55010) and clip (55515) sold separately.
Not interchangeable with weight distribution replacement parts.

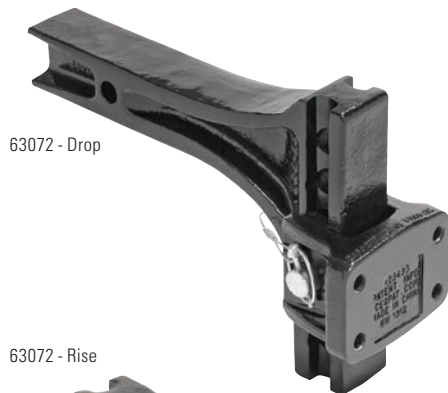

63072 - Drop



63072 - Rise

ADJUSTABLE PINTLE MOUNT

Tackle rough terrain with the toughest mount in. Adjustable for trailers of various heights and couplers. Converts quickly for a day of hassle-free towing.

- Fits 2 in. receivers, rated up to 14,000 lbs. GTW
- Adjust height up to 10-1/2 in.
- Adjustable cast shank, knurled bolt pin
- Black powder coat finish over E-coat

Part Number	Description	Length (in.)	Max Rise (in.)	Max Drop (in.)	Packaging	Master Carton
63072	Adjustable Pintle Mount, 14,000 lbs. GTW	9-5/8	4-1/4	6-1/4	Litho Box	2
Replacement Part						
63911	Replacement Cast Shank Only				Litho Box	1



2-1/2 IN. to 2 IN. REDUCER SLEEVES

- Ball mount reducer bushing
- 5/8 in. pin hole
- Allows for 2 in. hitch mounted accessories
- Black powder coat finish over E-coat

Part Number	Description	Sleeve Reduction (in.)	Packaging	Master Carton
58431	Reducer Sleeve with Collar	2-1/2 to 2	Display Label	1
58102	Reducer Sleeve	2-1/2 to 2	Display Label	1



3 IN. to 2 IN. REDUCER SLEEVES

- Ball mount reducer bushing
- 3/4 in. and 5/8 in. pin holes
- Allows for 2 in. hitch mounted accessories on Titan® Receivers
- Black powder coat finish over E-coat

Part Number	Description	Sleeve Reduction (in.)	Packaging	Master Carton
38735	Reducer Sleeve	3 to 2	Display Label	1



3 IN. to 2-1/2 IN. REDUCER SLEEVES

- Ball mount reducer sleeve
- 3/4 in. and 5/8 in. pin holes
- Allows for 2-1/2 in. hitch mounted accessories
- Can be used with weight distribution
- Metalshield™ finish

Part Number	Description	Sleeve Reduction (in.)	Packaging	Master Carton
58552	Reducer Sleeve	3 to 2-1/2	Display Label	2
58550	Reducer Sleeve with Collar	3 to 2-1/2	Display Label	2

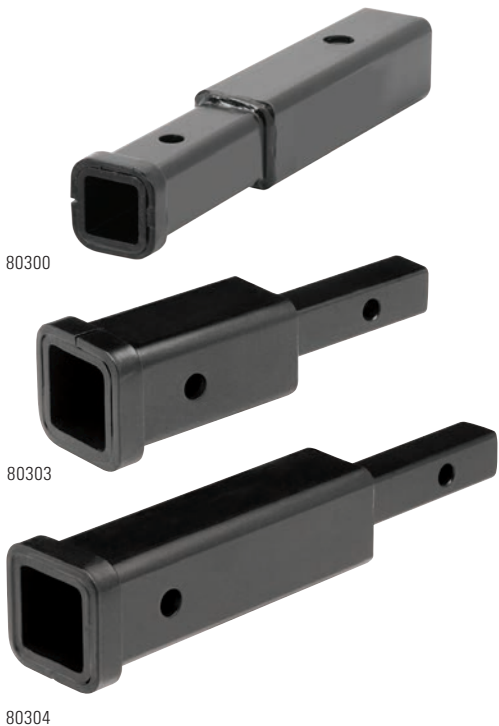

RECEIVER ADAPTERS

- Designed to extend the receiver opening from 6 in. to 14 in.
- Ideal for cargo carriers and bike carriers
- Use of this adapter reduces hitches' tow rating by 50%, with a maximum rating of 3,500 lbs. towing capacity
- Black powder coat finish over E-coat

Part Number	Description	Adapter Size (in.)	Capacity (lbs.)	Length (in.)	Packaging	Master Carton
80300	Receiver Adapter	2 to 1-1/4	3,500	7	Display Label	1
80301	Receiver Adapter	2 to 1-1/4	3,500	14	Display Label	1
80303	Receiver Adapter, Class II Only	1-1/4 to 2	3,500	6	Display Label	1
80304	Receiver Adapter, Class II Only	1-1/4 to 2	3,500	10	Display Label	1
Accessory						
58388	Class V Hitch Pin and Clip for 3" Square Receivers, 3/4"				Display Label	1

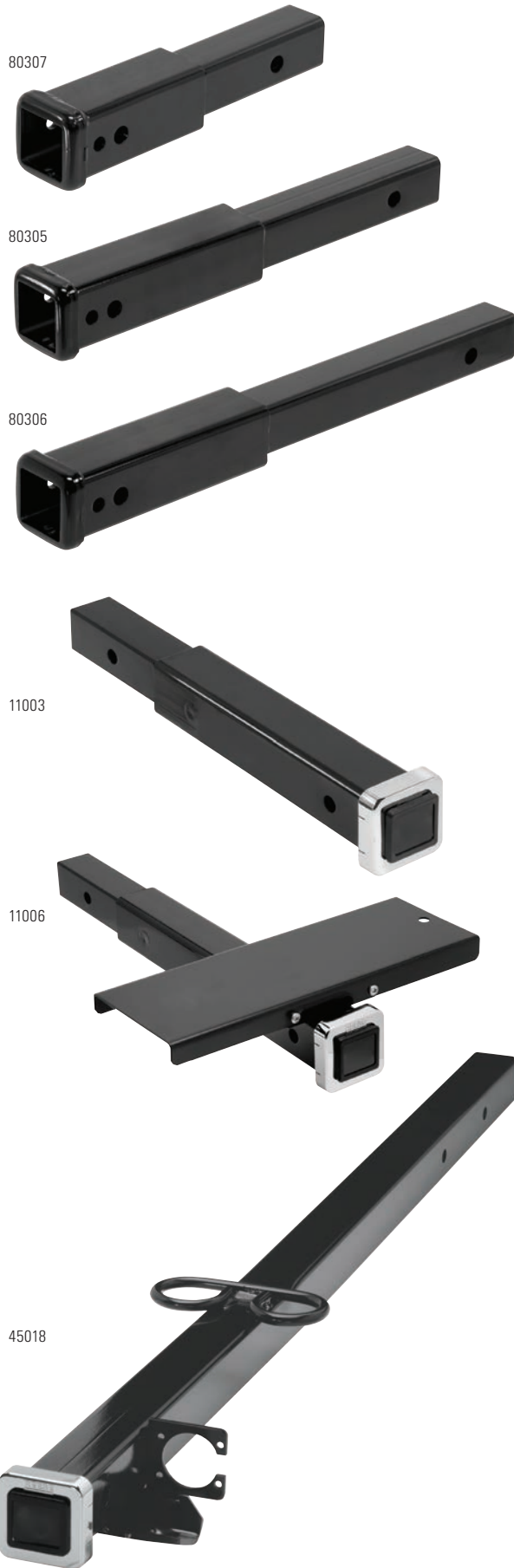

RECEIVER EXTENSIONS

- Ideal for slide-out campers with extended overhangs
- Designed to extend the receiver up to 18 in.
- 2 in. square tube opening for use with ball mounts and hitch-mounted accessories
- 3,500 lbs. weight carrying capacity

Part Number	Description	Weight Carrying (lbs.)	Weight Distribution (lbs.)	Length (in.)	Packaging	Master Carton
80307	Receiver Extension	3,500	-	8	Display Label	1
80305	Receiver Extension	3,500	-	14	Display Label	1
80306	Receiver Extension	3,500	-	18	Display Label	1

HEAVY DUTY RECEIVER EXTENSIONS

- Ideal for slide-out campers with extended overhangs
- Designed to extend the receiver up to 18 in.
- 2 in. square tube opening for use with ball mounts and hitch-mounted accessories
- 4,000 lbs. weight carrying capacity
- 6,500 lbs. weight distribution capacity

Part Number	Description	Weight Carrying (lbs.)	Weight Distribution (lbs.)	Length (in.)	Packaging	Master Carton
11003	HD Receiver Extension	4,000	6,500	14	Display Label	1
11004	HD Receiver Extension	4,000	6,500	18	Display Label	1
11006	HD Receiver Extension with Step	4,000	6,500	18	Display Label	1

2-1/2 IN. RECEIVER EXTENSIONS

- Ideal for slide-out campers with extended overhangs
- Designed to extend the receiver up to 48 in.
- 2 in. square tube opening for use with ball mounts and hitch-mounted accessories
- For 2-1/2 in. receivers
- Integrated electrical bracket attached
- Up to 6,000 lbs. weight carrying capacity
- Up to 7,500 lbs. weight distribution capacity

Part Number	Description	Weight Carrying (lbs.)	Weight Distribution (lbs.)	Length (in.)	Packaging	Master Carton
45292	2-1/2" Receiver Extension	6,000	8,000	24	Display Label	1
45018	2-1/2" Receiver Extension	5,000	7,500	41	Display Label	1
		4,000	6,000	48	Display Label	1

PINTLE MOUNTS

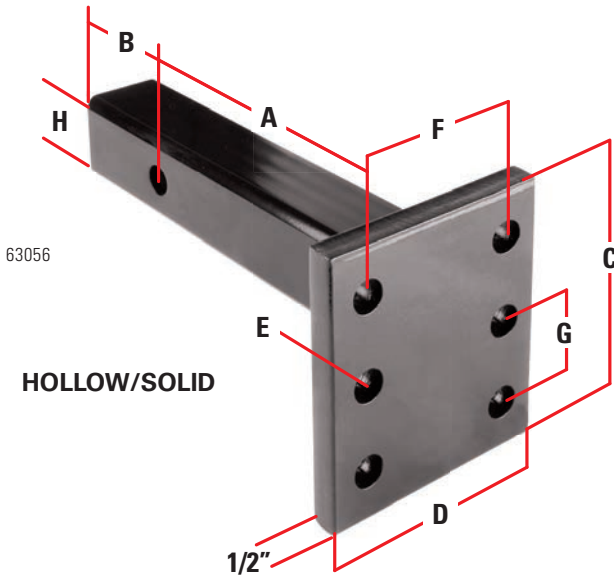

63056

HOLLOW/SOLID



45294

FORGED

PINTLE HOOK MOUNTS

- Converts receivers for use with pintle-type trailers, quickly and easily
- Provides mounting for both ball and pintle and rigid type pintle hooks
- Pin and clip must be ordered separately

Part Number	Shank	Rating GTW/TW (lbs.)	A Shank Length (in.)	B Length (in.)	H Shank (in.)	Shank Hole Diameter (in.)	C Height (in.)	D Width (in.)	E Mounting Hole (in.)	F Width (in.)	G Height (in.)	Hole Sets	Packaging	Master Carton
63056	Hollow	6,000/600	7-5/8	3	2	5/8	5-1/2	5	17/32	3-3/8	1-3/4	3	Litho Box	2
63057	Solid	12,000/1,200	7-5/8	3-1/4	2	5/8	7-1/2	5	17/32	3-3/8	1-3/4	4	Litho Box	2
63058	Solid	8,000/800	11-3/8	3-1/4	2	5/8	12-1/2	5	17/32	3-3/8	1-3/4	7	Litho Box	2
63059	Solid	12,000/1,200	11-3/8	3-1/4	2	5/8	7-1/2	5	17/32	3-3/8	1-3/4	4	Litho Box	2
45156	Hollow	12,000/1,200	7-3/4	3-1/4	2-1/2	5/8	6	5	17/32	3-3/8	1-3/4	3	Display Label	1
45294	Forged	18,000/2,000	8-1/2	4	2-1/2	5/8	7-1/4	5	17/32	3-3/8	1-3/4	4	Litho Box	1
38186	Forged	25,000/4,000	9	5	3	3/4	9	5	17/32	3-3/8	1-3/4	5	Display Label	1

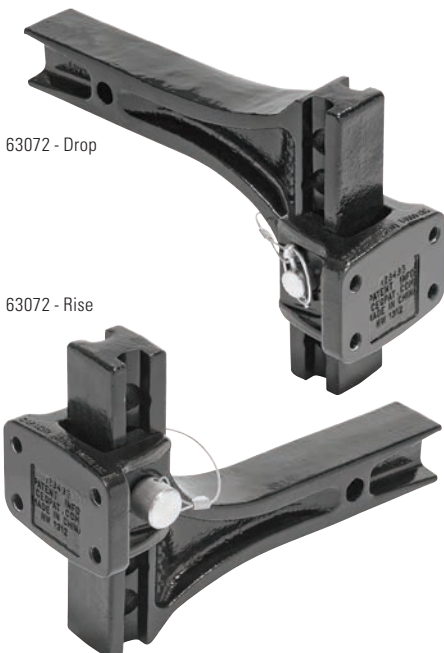

63072 - Drop

63072 - Rise

ADJUSTABLE PINTLE MOUNT

Tackle rough terrain with the toughest mount in. Adjustable for trailers of various heights and couplers. Converts quickly for a day of hassle-free towing.

- Fits 2 in. receivers, rated up to 14,000 lbs. GTW
- Adjust height up to 10-1/2 in.
- Adjustable cast shank, knurled bolt pin
- Black powder coat finish over E-coat

Part Number	Description	Length (in.)	Max Rise (in.)	Max Drop (in.)	Packaging	Master Carton
63072	Adjustable Pintle Mount, 14,000 lbs. GTW	9-5/8	4-1/4	6-1/4	Litho Box	2
Replacement Part						
63911	Replacement Cast Shank Only				Litho Box	1



63014



63016



63011



63012

PINTLE HOOKS

- Heavy duty pintle hook
- Safety pin and lanyard included
- Includes Grade 8 hardware
- Black powder coat finish over E-coat

Part Number	Description	GTW with Mounting Hardware (lbs.)	Max Vertical Load (lbs.)	Packaging	Master Carton
63013	5 Ton Pintle Hook	10,000	2,000	Litho Box	4
63014	10 Ton Pintle Hook	20,000	4,000	Litho Box	4
63015	15 Ton Pintle Hook	30,000	6,000	Litho Box	4
63016	30 Ton Pintle Hook	60,000	14,000	Litho Box	4
Replacement Parts					
63020	Replacement Snapper Pin, 1/4"			Display Card	20
63032	Replacement Hardware Mounting Kit, Plate Mounted Pintle Hooks/Combination Hitches			Poly Bag	1

8 TON BALL AND PINTLE HOOK COMBINATIONS

- Heavy duty pintle hook combo
- Safety pin and lanyard included
- Includes Grade 8 hardware
- Black powder coat finish over E-coat

Part Number	Ball Size (in.)	Ball Rating (lbs.)	GTW with Mounting Hardware (lbs.)	Max Vertical Load (lbs.)	Packaging	Master Carton
63010	1-7/8	6,000	16,000	3,000	Litho Box	4
63011	2	10,000	16,000	3,000	Litho Box	4
63012	2-5/16	14,000	16,000	3,000	Litho Box	4
Replacement Parts						
63050	1-7/8" Replacement Ball, 6,000 lbs., 1-1/8" Diameter				Bulk	6
63051	2" Replacement Ball, 10,000 lbs., 1-1/8" Diameter				Bulk	6
63052	2-5/16" Replacement Ball, 14,000 lbs., 1-1/8" Diameter				Bulk	6
63017	1-7/8" Replacement Ball, 6,000 lbs., 1-1/4" Diameter				Bulk	6
63018	2" Replacement Ball, 10,000 lbs., 1-1/4" Diameter				Bulk	6
63019	2-5/16" Replacement Ball, 14,000 lbs., 1-1/4" Diameter				Bulk	6
63020	Replacement Snapper Pin, 1/4"				Display Card	20
63032	Replacement Hardware Mounting Kit, Plate Mounted Pintle Hooks/Combination Hitches				Poly Bag	1

LUNETTE RINGS

- Designed with strength, durability and ease of use in mind
- Forged steel construction for high strength and wear resistance
- Simple bolt-on installation

Part Number	Description	Diameter (in.)	Capacity (lbs.)	Packaging	Master Carton
63023	4 Bolt Flange Lunette Ring	2-1/2	42,000	Litho Box	4
63036	Adjustable Lunette Ring with Hardware and Channel	3	24,000	Litho Box	4
63060	Adjustable Lunette Ring with Hardware	3	24,000	Litho Box	4
1291020383	Adjustable Lunette Ring	3	14,000	Bulk	288
1291020340	Adjustable Lunette Ring, Clear Zinc	3	14,000	Bulk	288

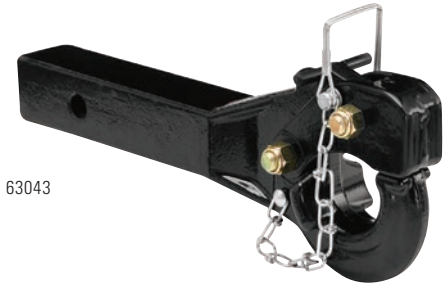

63043

RECEIVER MOUNT PINTLE HOOKS

- Fits 2 in. square receiver tube opening
- Solid shank
- Black powder coat finish over E-coat

Part Number	Description	Max GTW (lbs.)	Ball GTW (lbs.)	Max Vertical Load (lbs.)	Packaging	Master Carton
63043	5 Ton Receiver Mount Pintle Hook	10,000	-	2,000	Litho Box	2
63040	1-7/8" Receiver Mount Pintle Ball Combination	12,000	2,000	2,400	Litho Box	2
63041	2" Receiver Mount Pintle Ball Combination	12,000	7,000	2,400	Litho Box	2
63042	2-5/16" Receiver Mount Pintle Ball Combination	12,000	12,000	2,400	Litho Box	2



63041

RECEIVER MOUNT TOW EYELET

- Fits 2 in. square receiver tube opening
- 2-1/2 in. eyelet opening
- Solid shank
- Black powder coat finish over E-coat



63045

Part Number	Description	Max GTW (lbs.)	Length (in.)	Packaging	Master Carton
63045	Tow Eyelet, Forged	10,000	7-3/8	Litho Box	4

RECEIVER MOUNT TOW HOOK

- Fits 2 in. square receiver tube opening
- Solid shank
- Black powder coat finish over E-coat



63044

Part Number	Description	Max GTW (lbs.)	Length (in.)	Packaging	Master Carton
63044	Tow Hook, Forged	10,000	7-3/4	Litho Box	4

RECEIVER MOUNT TOW RING

- Fits 2 in. square receiver tube opening
- Solid shank
- Black powder coat finish over E-coat

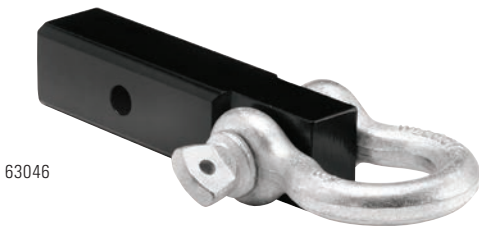

63046

Part Number	Description	Max GTW (lbs.)	Length (in.)	Packaging	Master Carton
63046	Tow Ring	8,000	7-3/8	Litho Box	4



6201

CLEVIS MOUNTS

- For use with industrial and agricultural equipment
- Includes pin and clip
- Black powder coat finish over E-coat

Part Number	Description	Ball Mount GTW/TW (lbs.)	Clevis Mount GTW/TW (lbs.)	Length (in.)	Packaging	Master Carton
5762	Clevis Mount, 1" Hole	6,000/600	6,000/600	9-3/4	Boxed	1
6201	Clevis Mount, 1" Hole	6,000/600	10,000/1,000	8-7/8	Boxed	1



63089

BALL MOUNT STORAGE

- Mountable in horizontal or vertical position
- Fits 2 in. ball mounts

Part Number	Description	Packaging	Master Carton
63089	2" Ball Mount Storage, (3 Pack)	PDQ Tray	3



63240



55010



63242



63258



63205



63203

PINS AND CLIPS

- Pins and clips are included with all Class I and Class II hitches

Part Number	Description	Packaging	Master Carton
63241	Class I/II Pin and Clip, 1/2", Groove Style	Clamshell	6
63240	Class III/IV Pin and Clip, 5/8", Groove Style	Plastic Shroud	6
63242	Class III/IV Pin and Clip, 5/8", Hole Style	Plastic Shroud	6
63243	Class V Pin and Clip, 5/8", Groove Style	Plastic Shroud	6
06237	Class I/II Pin, 1/2", Groove Style	Display Label	1
55010	Class III/IV Pin, 5/8", Groove Style	Display Label	1
58388	Class V Hitch Pin and Clip for 3" Square Receiver, 3/4"	Poly Bag	1
63258	Class V Hitch Pin and Clip for 3" Square Receiver, 3/4" Diameter, 4" Span	Plastic Shroud	3

SWIVEL LATCH PINS

Part Number	Description	Packaging	Master Carton
63203	5/8" Integral Pin and Clip, Stainless Steel	Clamshell	12
63204	1/2" Integral Pin and Clip, Zinc	Clamshell	12
63205	5/8" Integral Pin and Clip, Zinc	Clamshell	12



63201



J-PIN® STABILIZING PIN WITH LOCK

- More than just a hitch pin, J-Pin® quickly and confidently secures ball mounts and other hitch-mounted accessories, eliminating the sway and rattle caused by part clearance issues
- Ideal for bike racks and hitch-mounted cargo carriers
- Attachment wrench included
- Requires hitch with additional 17/32 in. hole in receiver tube
- Convenient 1/4 in. turn key for ease of use

Part Number	Description	Packaging	Master Carton
63201	J-Pin Anti-Rattle Pin with Barrel Lockset	Clamshell	1

63080



QSP™ HITCH SILENCING SYSTEM

- Designed to work with most Draw-Tite®, Class III 2 in. receivers (will not fit Ultra Frame models)
- Helps to tighten fit connection between receiver and accessory
- Reduces amount of sway in attached bike racks and cargo carriers
- High strength, aluminum construction collar and cam arm
- Magnetic, poly cover helps protect receiver from weather and debris
- Easy to install

Part Number	Description	Packaging	Master Carton
63080	QSP Hitch Silencing System, Draw-Tite	Poly Bag	50
63082	QSP Hitch Silencing System, Hidden Hitch	Poly Bag	50

63100



LOCK-TITE™ ANTI-RATTLE PIN

- Anti-Rattle device for cargo accessories, ball mounts, and more
- Handy insertion tool included
- Fits 2 in. receivers
- Keyed lock and wrench included
- Patent Pending

Part Number	Description	Packaging	Master Carton
63100	Lock-Tite Anti-Rattle Pin with Lock and Wrench, 5/8"	Clamshell	6

63091



ANTI-RATTLE DEVICE

- Used to significantly reduce rattling noise and movement of accessories that are inserted into a receiver style hitch (e.g. ball mounts, bike racks, ski racks, cargo racks, etc.)
- Steel constructed
- Hitch pin not included
- Black powder coat finish over E-coat

Part Number	Description	Packaging	Master Carton
63090	Anti-Rattle Device for 1-1/4" Square Receivers (Class I and II Receivers)	Poly Bag	24
63091	Anti-Rattle Device for 2" Square Receivers (Class III and IV Receivers)	Poly Bag	24

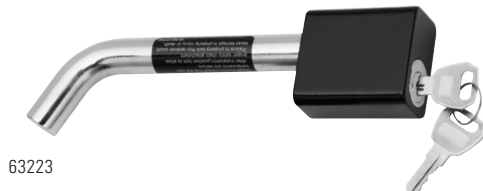
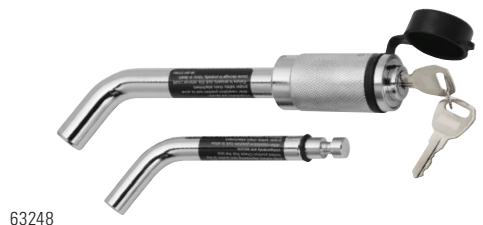
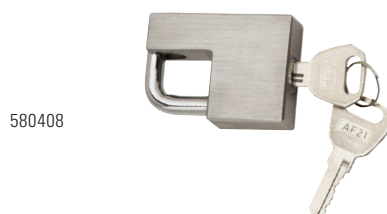

LIFELONG® LOCKS

- Delivers triple security
- Stronger break resistance
- Dual self-locking design
- High security square key design
- Includes dust cap

Part Number	Description	Packaging	Master Carton
580400	Chrome Bent Shank Lock for Class III and IV, 5/8" Diameter	Plastic Shroud	3
580401	Chrome Dogbone Lock for Class III and IV, 5/8" Diameter	Plastic Shroud	3
580402	Stainless Steel Dogbone lock for Class III and IV, 5/8" Diameter	Plastic Shroud	3
580403	Chrome Coupler Lock	Plastic Shroud	3
580404	Chrome Combo Lock Set, 5/8" Dogbone Receiver and Coupler for Class III and IV	Plastic Shroud	3

LOCKS

- Includes dust cap
- Easy access models feature side key entry and sliding dust cap
- Lock housing rotates 360°

Part Number	Description	Packaging	Master Carton
580405	Stainless Steel Dogbone Lock with Sleeve for 1-1/4" and 2" Square Receivers	Plastic Shroud	3
580406	Stainless Steel Combo Lock Set, 5/8" Dogbone Lock with Sleeve for 1-1/4" and 2" Square Receivers and Coupler	Plastic Shroud	3
580407	Easy Access Lock with Sleeve for 1-1/4" and 2" Square Receivers	Plastic Shroud	3
580408	Stainless Steel Coupler Lock	Plastic Shroud	6
580409	Easy Access Long Coupler Lock	Plastic Shroud	3
580410	Easy Access Adjustable Coupler Lock	Plastic Shroud	3

RECEIVER LOCKS

Part Number	Description	Packaging	Master Carton
63248	Bent Pin Lock with Extra Pin for 1-1/4" and 2" Square Receivers, 5/8" and 1/2" Diameters	Plastic Shroud	3
63224	Bent Pin Lock for 1-1/4" Square Receivers, Perfect for Fifth Wheel Base Rails, 1/2" Diameter	Plastic Shroud	6
63223	Bent Pin Lock for 2" and 2-1/2" Square Receivers, 5/8" Diameter	Plastic Shroud	3
63252	Dogbone Lock for 2-1/2" Square Receivers, 3-1/2" Span, Class V, 5/8" Diameter	Plastic Shroud	6
63253	Bent Pin Lock for 2-1/2" Square Receivers, 3-1/2" Span, Class V, 5/8" Diameter	Plastic Shroud	6

RECEIVER AND COUPLER LOCKS



RECEIVER LOCKS

Part Number	Description	Packaging	Master Carton
580412	Receiver Lock, Dogbone Style, 5/8" for 2-1/2" Square Receivers, Class V	Plastic Shroud	6
63259	Receiver Lock, Dogbone Style, 5/8" for 3" Square Receivers, Sleeved to 3/4", Class V	Plastic Shroud	3
63260	Receiver Lock, 5/8" for 3" Square Receivers, Sleeved to 3/4", Ball Bearing Pick Proof Design, Class V	Plastic Shroud	3
7006100	Combo Lock Set, Bent Pin Receiver Lock, 1/2" and 5/8" and Coupler Lock Set	Plastic Shroud	3



TRAILER COUPLER LOCKS

Part Number	Description	Packaging	Master Carton
63225	Coupler Lock, Fits Most Straight Tongue Couplers, 1/4" Pin Diameter, 3/4" Span	Plastic Shroud	3
63227	Coupler Lock for 2-5/16" Ball	Clamshell	6
63228	Coupler Lock for 2" Ball	Clamshell	6
55003	Universal Coupler Lock, Fits 1-7/8", 2" and 2-5/16" Couplers, Yellow	Display Bag	1
72783	Universal Coupler Lock, Fits 1-7/8", 2" and 2-5/16" Couplers, Yellow	Display Card	3
7005300	Adjustable Coupler Lock, Brass	Plastic Shroud	6



ADJUSTABLE BALL MOUNT COMBO LOCK SET

- 5/8 in. lock for 2 in. square receivers
- 3/4 in. lock for adjustable ball mount head unit
- Keyed alike

Part Number	Description	Packaging	Master Carton
63069	Combo Lock Set, 5/8" for 2" Square Receivers and 3/4" for Accessory (Keyed Alike)	Display Card	6



TOW & STORE™ LOCK SET

- Guards against towed and parked trailer thefts
- Universal coupler lock: 1-7/8 in., 2 in., 2-5/16 in.
- Dual bent pin lock: 1/2 in., 5/8 in.
- Adjustable coupler lock: 5/8 in., 1 in.
- 3 interchangeable keys
- Carry case included

Part Number	Description	Packaging	Master Carton
63256	Tow & Store Lock Set, Universal Coupler Lock, Trailer Lock and Receiver Lock, Keyed Alike	Litho Box	2



CABLE LOCKS

- Secures items to vehicle

Part Number	Description	Packaging	Master Carton
CLK15 0100	Cable Lock with Key, 3/16" x 15' Length	Display Bag	6
63255	Cable Lock, 5/16" x 4' Length	Display Card	3



63300

HITCH AND TRAILER ALIGNMENT TOOL

- Convenient one person hitch alignment system
- Magnetic base for fast and easy location
- Telescoping rods adjust up to 42 in.
- Easy to use the first time

Part Number	Description	Packaging	Master Carton
63300	Hitch and Trailer Alignment Tool	Clamshell	3

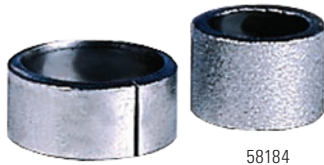

58109

58184

HITCH BALL REDUCER BUSHINGS

Part Number	Description	Packaging	Master Carton
58109	Reducer Bushing, 1" Hitch Ball Shank Hole to 3/4"	Clamshell	6
58184	Reducer Bushing, 1-1/4" Hitch Ball Shank Hole to 1"	Clamshell	6



58117

HITCH BALL LUBE

- Reduces friction
- Will not break down
- Non-toxic

Part Number	Description	Packaging	Master Carton
58117	Hitch Ball Lube, 4 oz. Jar	Jar	12



74342

HITCH BALL WRENCH

- Allows one wrench to tighten hitch balls
- 1-1/8 in. and 1-1/2 in. - boxed on both ends

Part Number	Description	Packaging	Master Carton
74342	Hitch Ball Wrench, Boxed End 1-1/8" and 1-1/2"	Bulk	5



7010

RECEIVER TUBE COVERS

Part Number	Description	Packaging	Master Carton
60037	Class I/II, Rubber 1-1/4" Square with Hidden Hitch Logo	Bulk	30
1202	Receiver Tube Cover, 2" Square, Black	Bulk	24
5363	Receiver Tube Cover, 2" Square, Black	Display Card	1
5362	Rubber Receiver Tube Cover, 1-1/4" Square with "D" Draw-Tite Logo	Display Card	1
2211	Rubber, 1-1/4" Square with "D" Draw-Tite Logo	Display Card	1
7050	Rubber, 2" Square with "D" Draw-Tite Logo	Display Card	1
7010	Rubber, 2" Square with "D" Draw-Tite Logo	Display Card	1



42251

HITCH BALL COVER

- Rubber construction for tight fit

Part Number	Description	Packaging	Master Carton
42251	Hitch Ball Cover	Bulk	16

STANDARD HITCH BALLS

 **LAST CHANCE**

Part Number	Finish	Ball Diameter (in.)	Shank Diameter (in.)	Shank Length (in.)	Drawbar Thickness (in.)	Capacity (lbs.)	Packaging	Master Carton
63811†	Zinc	1-7/8	3/4	1-1/2	3/8 - 5/8	2,000	Bulk	12
63813†	Zinc	1-7/8	3/4	2-3/8	3/8 - 1-3/8	2,000	Bulk	12
63817†	Zinc	1-7/8	1	2-1/8	3/8 - 3/4	2,000	Bulk	12
63819†	Zinc	1-7/8	1	3-3/8	3/8 - 2-1/8	2,000	Bulk	12
63881†	Zinc	1-7/8	3/4	1-1/2	3/8 - 5/8	2,000	Plastic Shroud	3
63885†	Zinc	1-7/8	1	2-1/8	3/8 - 3/4	2,000	Plastic Shroud	3
63818†	Chrome	1-7/8	1	3-3/8	3/8 - 2-1/8	2,000	Bulk	12
63810-006†	Chrome	1-7/8	3/4	1-1/2	3/8 - 5/8	2,000	PDQ Tray (6 Pack)	1
63816-006†	Chrome	1-7/8	1	2-1/8	3/8 - 3/4	2,000	PDQ Tray (6 Pack)	1
63821†	Zinc	2	3/4	1-1/2	3/8 - 5/8	3,500	Bulk	12
63823†	Zinc	2	3/4	2-3/8	3/8 - 1-3/8	3,500	Bulk	12
63848†	Zinc	2	1	2-1/8	3/8 - 3/4	7,500	Bulk	12
63850†	Zinc	2	1	3-1/4	3/8 - 2-1/8	7,500	Bulk	12
63831†	Zinc	2	1-1/4	2-3/4	3/8 - 1	8,000	Bulk	12
63888†	Zinc	2	3/4	1-1/2	3/8 - 5/8	3,500	Plastic Shroud	3
63910†	Zinc	2	1	2-1/8	3/8 - 3/4	7,500	Plastic Shroud	3
63845-006†	Chrome	2	1	2-1/8	3/8 - 3/4	7,500	PDQ Tray (6 Pack)	1
028375†	Precision Machined	2	3/4	2-1/8	3/8 - 3/4	3,000	Bulk	12
028351†	Precision Machined	2	1	2-1/8	3/8 - 3/4	5,000	Bulk	12
028352†	Precision Machined	2	1	2-1/8	3/8 - 3/4	7,000	Bulk	12
63846†	Zinc	2-5/16	1	2-1/8	3/8 - 3/4	7,500	Bulk	12
63835†	Zinc	2-5/16	1-1/4	2-3/4	3/8 - 1	12,000	Bulk	12
63907†	Zinc	2-5/16	1	2-1/8	3/8 - 3/4	7,500	Plastic Shroud	3
63897†	Zinc	2-5/16	1-1/4	2-3/4	3/8 - 1	12,000	Plastic Shroud	3
63847-006†	Chrome	2-5/16	1	2-1/8	3/8 - 3/4	7,500	PDQ Tray (6 Pack)	1
028400†	Precision Machined	2-5/16	1-1/4	2-3/4	3/8 - 1	12,500	Bulk	12

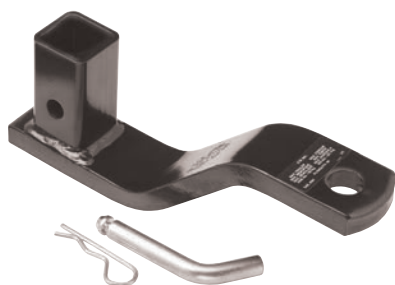

83637†

OEM DRAWBAR KIT

 **LAST CHANCE**

Part Number	Description	Substitute Part Number	Packaging	Master Carton
83637†	OEM Drawbar Kit, 2,000 lbs. Capacity, 3/4" Ball Hole Size	-	Boxed	1



40446†

PACKAGED ANGLE CUT BALL MOUNTS

 **LAST CHANCE**

Part Number	Description	Substitute Part Number	Packaging	Master Carton
40443†	Angle Cut Ball Mount, 6,000 lbs. Capacity, 1" Ball Hole Size, 10-1/2" Length, 3/4" Rise and 2" Drop	40343	Boxed	1
40446†	Angle Cut Ball Mount, 6,000 lbs. Capacity, 1" Ball Hole Size, 9-1/2" Length, 4-3/4" Rise and 6" Drop	40346	Boxed	2

† = Available while supplies last



EASY LOAD BALL MOUNTS

LAST CHANCE

Part Number	Description	Substitute Part Number	Packaging	Master Carton
40342-006†	Easy Load Ball Mount, 7,500 lbs. Capacity, 1" Ball Hole Size, 8-1/2" Length, 3/4" Rise and 2" Drop, (6 Pack)	40342	Boxed	1
40343-006†	Easy Load Ball Mount, 6,000 lbs. Capacity, 1" Ball Hole Size, 10-1/2" Length, 3/4" Rise and 2" Drop, (6 Pack)	40343	Boxed	1
40344-006†	Easy Load Ball Mount, 7,500 lbs. Capacity, 1" Ball Hole Size, 9" Length, 2-3/4" Rise and 4" Drop, (6 Pack)	40344	Boxed	1
40345-006†	Easy Load Ball Mount, 6,000 lbs. Capacity, 1" Ball Hole Size, 11" Length, 2-3/4" Rise and 4" Drop, (6 Pack)	40345	Boxed	1
40346-002†	Easy Load Ball Mount, 7,500 lbs. Capacity, 1" Ball Hole Size, 9-1/2" Length, 4-3/4" Rise and 6" Drop, (6 Pack)	40346	Boxed	1



UTILITY BALL MOUNTS

LAST CHANCE

Part Number	Description	Substitute Part Number	Packaging	Master Carton
2736-006†	Utility Ball Mount, 5,000 lbs. Capacity, 1" Ball Hole Size, 12" Length, 3/4" Rise and 2" Drop, (6 Pack)	2736	Boxed	1
2793-002†	Utility Ball Mount, 5,000 lbs. Capacity, 1" Ball Hole Size, 10" Length, 6-3/4" Rise and 8" Drop, (2 Pack)	2793	Boxed	1



TOWING STARTER KITS

LAST CHANCE

Part Number	Description	Substitute Part Number	Packaging	Master Carton
40584-002†	Draw-Tite Starter Kit, 7,500 lbs. Capacity, 1" Ball Hole Size, 8-1/2" Length, 2" Rise and 2" Drop, (2 Pack)	40583-002	PDQ Tray	1
80058-002†	Hidden Hitch Starter Kit, 7,500 lbs. Capacity, 1" Ball Hole Size, 8-1/2" Length, 2" Rise and 2-5/16" Drop, (2 Pack)	40058-002	PDQ Tray	1
80472-002†	Hidden Hitch Starter Kit, 7,500 lbs. Capacity, 1" Ball Hole Size, 9" Length, 4" Rise and 2-5/16" Drop, (2 Pack)	40238-002	PDQ Tray	1
80583-002†	Hidden Hitch Starter Kit, 7,500 lbs. Capacity, 1" Ball Hole Size, 8-1/2" Length, 2" Rise and 2" Drop, (2 Pack)	40583	PDQ Tray	1
80644-002†	Hidden Hitch Starter Kit, 7,500 lbs. Capacity, 1" Ball Hole Size, 9" Length, 4" Rise and 2" Drop, (2 Pack)	40644-002	PDQ Tray	1
83058-002†	REESE Starter Kit, 7,500 lbs. Capacity, 1" Ball Hole Size, 8-1/2" Length, 2" Rise and 2-5/16" Drop, (2 Pack)	40058-002	PDQ Tray	1
83238-002†	REESE Starter Kit, 7,500 lbs. Capacity, 1" Ball Hole Size, 9" Length, 4" Rise and 2-5/16" Drop, (2 Pack)	40238-002	PDQ Tray	1
83583-002†	REESE Starter Kit, 7,500 lbs. Capacity, 1" Ball Hole Size, 8-1/2" Length, 2" Rise and 2" Drop, (2 Pack)	40583-002	PDQ Tray	1
83644-002†	REESE Starter Kit, 7,500 lbs. Capacity, 1" Ball Hole Size, 9" Length, 4" Rise and 2" Drop, (2 Pack)	40644-002	PDQ Tray	1

† = Available while supplies last

40331-002†



SOLID FORGED BALL MOUNTS **LAST CHANCE**

Part Number	Description	Substitute Part Number	Packaging	Master Carton
40330-002†	Solid Forged Ball Mount, 16,000 lbs. Capacity, 1-1/4" Ball Hole Size, 8-1/2" Length, 1" Rise and 2" Drop, (2 Pack)	40330	Boxed	1
40331-002†	Solid Forged Ball Mount, 16,000 lbs. Capacity, 1-1/4" Ball Hole Size, 9-1/4" Length, 3" Rise and 4" Drop, (2 Pack)	40331	Boxed	1
40332-002†	Solid Forged Ball Mount, 16,000 lbs. Capacity, 1-1/4" Ball Hole Size, 10-1/4" Length, 5" Rise and 6" Drop, (2 Pack)	40332	Boxed	1

80795†



DUAL-BALL SOLID SHANKS **LAST CHANCE**

Part Number	Description	Substitute Part Number	Packaging	Master Carton
80795†	Dual Ball Mount with Black Balls, 8" Length, 1-7/8" Ball - 2,000 lbs. Capacity, 2" Ball - 10,000 lbs. Capacity	80796	Boxed	2
80797†	Dual Ball Mount with Chrome Balls, 8" Length, 1-7/8" Ball - 2,000 lbs. Capacity, 2" Ball - 10,000 lbs. Capacity	80798	Boxed	2

80404†



DUAL-BALL HALLOW SHANK **LAST CHANCE**

Part Number	Description	Substitute Part Number	Packaging	Master Carton
80404†	Dual Ball Mount with Hollow Shank, Rise - 1-7/8" Ball, 2,000 lbs. Capacity, Drop - 2" Ball - 6,000 lbs. Capacity	80406	Boxed	1

6580†



ADJUSTABLE HOLLOW SHANK BALL MOUNT **LAST CHANCE**

Part Number	Description	Substitute Part Number	Packaging	Master Carton
6580†	Complete Shank and Head Assembly with Quick Release Pin and Clip, 6,000 lbs. Capacity, 12" Length, 6-1/8 Max Rise, and 7-3/8" Max Drop	21141	Boxed	1

80410†



CLEVIS MOUNTS **LAST CHANCE**

Part Number	Description	Substitute Part Number	Packaging	Master Carton
80410†	Clevis Mount, 1" Hole, -Ball Mount has 1-1/4" Drop, -Clevis Mount has 3" Drop, 6,000 lbs. Capacity, 11" Length	5762	Boxed	1

63047†



RECEIVER MOUNT TOW HOOK **LAST CHANCE**

Part Number	Description	Substitute Part Number	Packaging	Master Carton
63047†	Tow Hook, 8,000 lbs. Capacity, 7" Length	63044	Boxed	2

† = Available while supplies last

63202†



SWIVEL LATCH HITCH PIN

LAST CHANCE

Part Number	Description	Substitute Part Number	Packaging	Master Carton
63202†	1/2" Integral Pin and Clip, Stainless Steel	63204	Clamshell	12

55515†



PIN CLIP

LAST CHANCE

Part Number	Description	Substitute Part Number	Packaging	Master Carton
55515†	Pin Clip	55010	Boxed	1

63216KA†

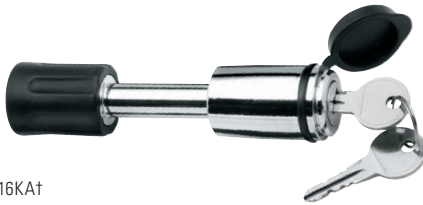

COUPLER/HITCH LOCKS

LAST CHANCE

Part Number	Description	Substitute Part Number	Packaging	Master Carton
63216KA†	KEYED ALIKE 1/2" Receiver Lock for Class II Receiver Hitches	63069	Clamshell	1
63218KA†	KEYED ALIKE Class II 1/2" Receiver Lock and 1/2" Span Style Coupler Lock	63069	Clamshell	1
63219KA†	KEYED ALIKE Class III & IV 5/8" Receiver Lock and 1/2" Span Style Coupler Lock	63069	Clamshell	1
63220KA†	KEYED ALIKE 1/2" Span Style Coupler Lock	63069	Clamshell	1
63221KA†	KEYED ALIKE 2" Span Style Coupler Lock with 1/4" Pin	63069	Clamshell	1
63222KA†	KEYED ALIKE 2-1/2" Span Style Coupler Lock with 1/4" Pin	63069	Clamshell	1

63233†



CABLE LOCK

LAST CHANCE

Part Number	Description	Substitute Part Number	Packaging	Master Carton
63233†	Cable Lock, 5/16" x 10'	63255	Display Card	3

63250†



COMBO LOCK SET

LAST CHANCE

Part Number	Description	Substitute Part Number	Packaging	Master Carton
63250†	Combo Lock Set, 5/8" for 3" Square Receivers, Sleeved to 3/4" (Keyed Alike)	63069	Plastic Shroud	6

63801†



INTERCHANGEABLE HITCH BALL SYSTEM

LAST CHANCE

Part Number	Description	Substitute Part Number	Packaging	Master Carton
63801†	Interchangeable Hitch Ball, 3/4" Shank, 1-7/8" and 2" Balls, 5,000 lbs. Rating	63802	Clamshell	2
63804†	Interchangeable Hitch Ball, 1" Shank, 2" and 2-5/16" Balls, 8,000 lbs. Rating	63803	Clamshell	2
63805†	1-7/8" Interchangeable Hitch Ball Head	63802	Clamshell	2
63806†	2" Interchangeable Hitch Ball Head	63802	Clamshell	2
63807†	2-5/16" Interchangeable Hitch Ball Head	63803	Clamshell	2
63808†	3/4" Interchangeable Hitch Ball Shank	63802	Clamshell	2
63809†	1" Interchangeable Hitch Ball Shank	63803	Clamshell	2

† = Available while supplies last



60037-024†



74547†

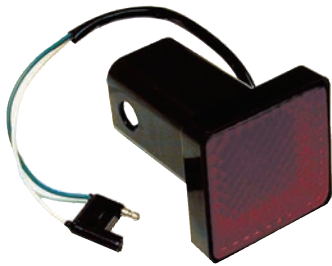

80980†



42250†



5764†



63100-0025†



80100†

† = Available while supplies last

RECEIVER TUBE COVERS

LAST CHANCE

Part Number	Description	Substitute Part Number	Packaging	Master Carton
80037-012†	Class III Cover, Rubber 2" Square with Hidden Hitch Logo, (12 Pack)	7050	-	-
05330-010†	"Hitch Hider" Rubber Receiver Tube Cover, 2" Square with Built-In 4-Way Flat Electrical Cover, (10 Pack)	5330	-	-
5351†	Receiver Tube Cover, 1-1/4" Square, Chrome	2211	-	-
5352†	Receiver Tube Cover, 2" Square, Chrome	7050	-	-
07010-024†	Receiver Tube Cover, 2" Square with "D" Draw-Tite Logo, (24 Pack)	7010	-	-
58070†	Receiver Tube Cover, 1-1/4" Square, Black, Nylon, (24 Pack)	2211	-	-
60037-024†	Class I/II, Rubber 1-1/4" Square with Hidden Hitch Logo, (24 Pack)	60037	-	-
74547†	Receiver Tube Cover, 2" Square with REESE Logo	7050	-	-
80037†	Class III Cover, Rubber 2" Square with Hidden Hitch Logo	7050	-	-
74099†	Receiver Tube Cover, 2" Square with REESE Logo	7050	-	-
80953†	Receiver Tube Cover, 2" Square, Plastic	7050	-	-
5330†	"Hitch Hider" Rubber Receiver Tube Cover, 2" Square with Built-In 4-Way Flat Electrical Cover	5330	-	-

BRAKE LIGHT COVER

LAST CHANCE

Part Number	Description	Substitute Part Number	Packaging	Master Carton
80980†	Brake Light Cover, 2" Square	-	Boxed	1

HITCH BALL COVERS

LAST CHANCE

Part Number	Description	Substitute Part Number	Packaging	Master Carton
42250†	Hitch Ball Cover, 1-7/8" to 2"	42251	-	-
42250-012†	Hitch Ball Cover, 1-7/8" to 2", (12 Pack)	42251	-	-
42251-012†	Hitch Ball Cover, 2-5/16" (12 Pack)	42251	-	-

CLEVIS MOUNT PIN

LAST CHANCE

Part Number	Description	Substitute Part Number	Packaging	Master Carton
5764†	Clevis Mount Pin, 1" Diameter, 8-7/8" Length	58388	-	-

LOCK-TITE™ ANTI-RATTLE PIN

LAST CHANCE

Part Number	Description	Substitute Part Number	Packaging	Master Carton
63100-025†	Lock-Tite Anti-Rattle Pin with Lock and Wrench, 5/8", (25 Pack)	63100	Clamshell	1

HITCH BALL REDUCER BUSHINGS

LAST CHANCE

Part Number	Description	Substitute Part Number	Packaging	Master Carton
80100†	Reducer Bushing 1" to 3/4"	58109	Clamshell	6
80106†	Reducer Bushing 1-1/4" to 1"	58184	Clamshell	6



ELECTRICAL WIRING

The most trusted names in towing safety dating back to 1931, Tekonsha®, Wesbar® and Bargman® specialize in production, design and engineering of custom wire harnesses and cable assemblies. Our in-house overmolding and custom mold capabilities, design and engineering, and expertise in electronic cable assembly give us an unparalleled advantage in meeting our customers' needs. We specialize in assemblies with multiple connections, varying wire lengths and mixed technologies. We are known for design liaison expertise, quick response, building to AVL, customer service, and for consistently producing the best product, manufactured on time, to rigorous quality standards.

T-ONE® CONNECTORS C-5

FACTORY TOW HARNESSSES

Tow Plugs C-6
 Wire Harnesses C-6
 7-Way U.S. Car Electrical Connectors C-6
 7-Way Vehicle Complete Kits C-6

MODULITE® POWER MODULES

ModuLite® ZCI™ C-8
 ModuLite® HD Plus C-8
 ModuLite® HD Protector C-9
 ModuLite® Ultra C-10
 ModuLite® Wiring Kits and Harnesses C-10

TAIL LIGHT CONVERTERS

Converter with Circuit Protection C-11
 2 to 3-Way Converter C-11
 Isolating Diode System C-11

WIRE HARNESSSES

2-Way C-14
 4-Way C-12 - C-14
 5-Way C-15
 6-Way C-16
 7-Way C-17 - C-23
 90-Degree Complete Kit C-22
 Agricultural Harnesses C-24 - C-25

ELECTRICAL ACCESSORIES

Dust Covers C-14
 Vehicle and Trailer Adapters C-26 - C-27
 Mounting Brackets C-28 - C-29
 Junction Boxes C-30
 Battery Post Adapters and Isolators C-31
 Wiring and Hardware Components C-32
 Electrical and Circuit Testers C-33

DISCONTINUED PRODUCTS C-34

FEATURED

MODULITE® ZCI™ - (ZERO CONTACT INTERFACE)

ZCI™ is the only product in the industry that has ZERO contact with the vehicle's electrical system. Using sensors that easily snap around wires for no direct contact, when electrical current is detected lights are engaged. Our ZCI™ sensors easily snap over wires to detect an electrical current and engage trailer lights -- crucial for high-end vehicles with complex wiring in which snipping, cutting, or splicing voids the vehicle's electrical system warranty. Have a leased vehicle? The ZCI™ is easy to remove without leaving any permanent damage. Take to your next vehicle with the same easy installation.

- Snap, Don't Snip™ – No cutting or splicing vehicle wiring!
- Isolates trailer light operation from the tow vehicle's electrical system
- See page C-8 for additional information



7-WAY VEHICLE COMPLETE KITS

No other product is designed to specifically deliver everything needed for a fully functional 7-Way, INCLUDING a brake control plug. No more piecing together products. These kits are custom made and will REDUCE the installation time of installing fully functional 7-Ways.

- The FIRST 7-Way kits that include:
 - Plug & Play connector for the brake control
 - Custom made body harnesses with protective tubing
 - Robust hardwire kit with longer and more cable ties
 - Overload and short circuit protection on Turn/Brake, Tail and Reverse
- See page C-6 for additional information including vehicle specific applications



90° 7-WAY PRE-WIRED CABLES FOR HOOK-UP OF FIFTH WHEEL AND GOOSENECK TRAILERS

- 7-Way 90° connector molded to heavy duty 7-Way insulated cable for fifth wheel or gooseneck trailer applications
- Allows remote wiring in pickup beds or other hard to access areas
- 90° molded from flame retardant material
- Features a patented mounting bracket that allows for installation in virtually all pickup models and styles and includes self-tapping stainless steel mounting screws
- Manufactured with UL listed 10/2, 12/1 and 14/4 jacketed cable
- See page C-21 for additional information



SELECTING THE CORRECT ELECTRICAL PRODUCT

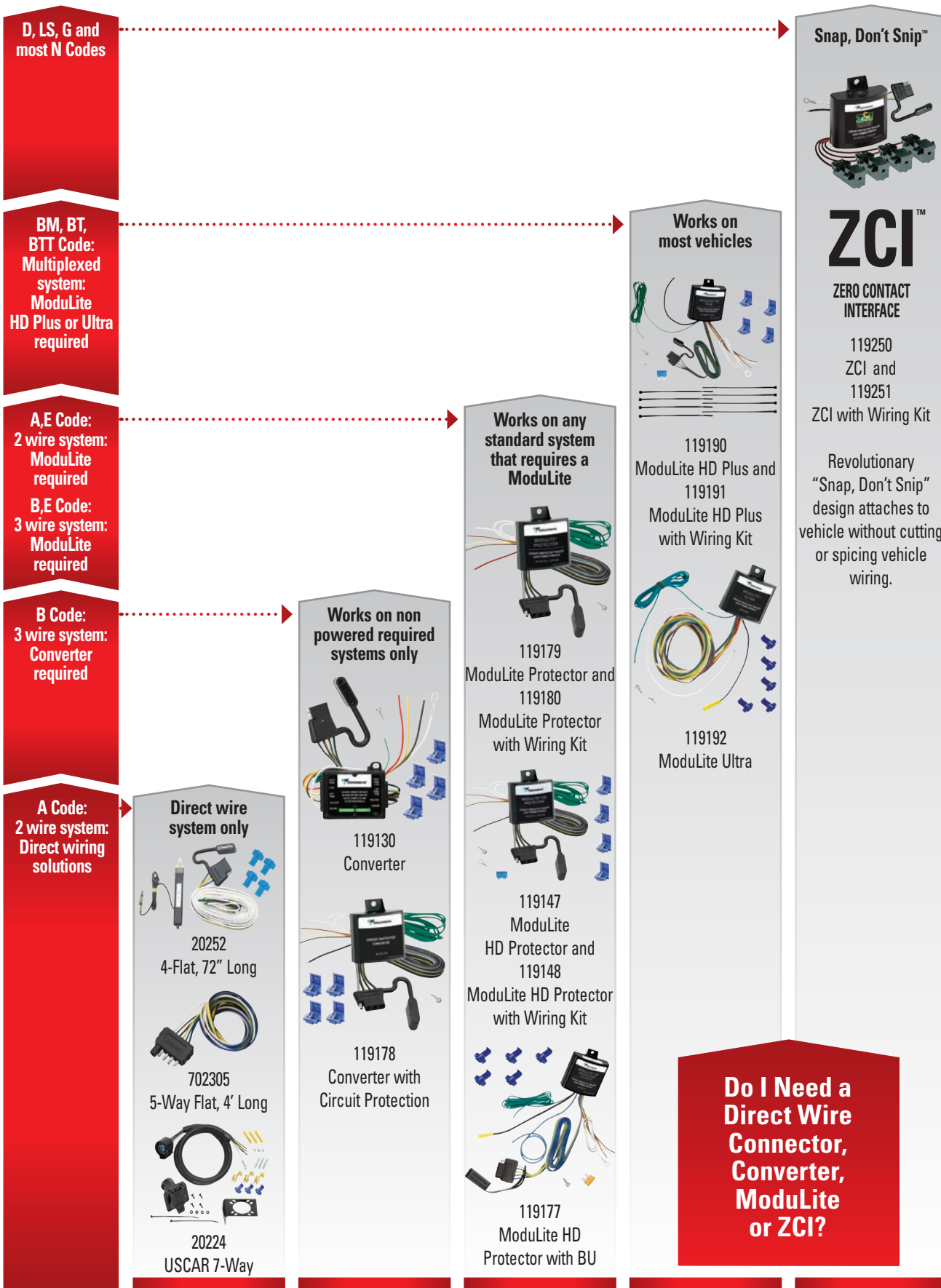

A Code: 2 wire system.

Vehicles are listed as A when the vehicle's system matches the trailer's 2 wire system. You will know it is a 2 wire system if the vehicle's turn and brake functions are combined on one wire and the tail light function is on a separate wire. It is also important to make sure the vehicle's system is able to handle a normal load expected from one set of trailer lights. Directly wiring into the vehicle's system does not protect the vehicle from shorts or overloads. To ensure maximum vehicle protection and maximum trailer light brightness, a ModuLite® should be used.

B Code: 3 wire system. Converter required.

Vehicles are listed as B when the vehicle's system is different than the trailer's 2 wire system. This is when each function - turn, brake, and tail light - are on separate wires (3 wire system) and it has been determined that the vehicle's system is able to handle a normal load expected from one set of trailer lights. To ensure maximum vehicle protection and maximum trailer light brightness, a ModuLite® should be used.

A,E Code: 2 wire system. ModuLite® required.

Vehicles are listed as A,E when the vehicle's system matches the trailer's 2 wire system, meaning the vehicle's turn and brake functions are combined on one wire and the tail light function is on a separate wire. It has been determined that the vehicle's system is NOT able to handle a normal load expected from one set of trailer lights. When installing the ModuLite®, the brake input (red wire) will not be used.

B,E Code: 3 wire system. ModuLite® required.

Vehicles are listed as B,E when the vehicle's system is different than the trailer's 2 wire system, meaning the vehicle's functions are shared on one wire, the vehicle uses different voltages and frequencies to activate the rear combinations lamps, and the vehicle systems are NOT able to handle a normal load expected from one set of trailer lights. When installing the ModuLite® all input wires are used.

BM Code: Multiplexed wiring system. ModuLite® HD Plus or Ultra required.

Vehicles are listed as BM when the vehicle's system is different than the trailer's 2 wire system, meaning the vehicle's functions are shared on one wire, the vehicle uses different voltages and frequencies to activate the rear combinations lamps, and the vehicle systems are NOT able to handle a normal load expected from one set of trailer lights. Either the ModuLite® HD Plus or Ultra is required.

At time of installation, determine the type of the vehicle's shared system. For vehicles that share a tail and brake circuit, the tail input (brown wire) is not used. For vehicles that share a tail, brake and turn circuit the tail input (brown wire) and brake input (red wire) are not used.

BT Code: Brake/Tail multiplexed wiring system. ModuLite® HD Plus or Ultra required.

Vehicles are listed as BT when the vehicle's system is different than the trailer's 2 wire system. This means the vehicle's brake and tail functions are combined on one wire, the turn function is on a separate wire (known as multiplexed share brake and tail), and it has been determined that the vehicle's system is NOT able to handle a normal load expected from one set of trailer lights. When installing the ModuLite® HD Plus or Ultra, the tail input (brown wire) is not used.

BTT Code: Brake/Tail/Turn multiplexed wiring system. ModuLite® HD Plus or Ultra required.

Vehicles are listed as BTT when the vehicle's system is different than the trailer's 2 wire system, meaning the vehicle's brake, tail, and turn functions are combined on one wire (known as multiplexed shared brake, tail, and turn), and it has been determined that the vehicle's system is NOT able to handle a normal load expected from one set of trailer lights. When installing the ModuLite® HD Plus or Ultra, the tail input (brown wire) and brake input (red wire) are not used.



118384 -
RAM 3500

T-ONE® CONNECTORS

With more than 470 products covering 8,700 vehicle applications, Tekonsha® is pleased to offer the widest coverage of T-One® Connectors in the industry.

- Benefits of our Tekonsha® T-Ones include:
 - “Factory” appearance
 - Quick and easy installation
 - Solid construction, built with our surface mount technology
 - Weatherproof connection when needed
 - No cutting, splicing or taping of vehicle wires
 - Includes ModuLite® or converter where needed
 - 16 gauge bonded wire with 4-Flat plug and integrated cap
- See application guide for vehicle specific applications



20137

MULTI-PLUG T-ONE® CONNECTORS

- Ability to tow trailers with different style trailer connectors
- Durable plastic shell
- Weather tight seal
- See application guide for fit information

Part Number	Description	Packaging	Master Carton
20135	7-Way/4-Flat Multi-Plug T-One Connector	Clamshell	3
20137	7-Way/4-Flat Multi-Plug T-One Connector	Clamshell	3
74682	7-Way/4-Flat Multi-Plug T-One Connector	Clamshell	3



1. Locate wiring position, see chart on page A-140



2. Unplug the tail light harness.



3. Route T-One® Connector to the tail light harness.



4. Plug the tail light into the T-One® connector.



5. Re-secure the tail light and you're ready to tow!



NOTE: Some vehicles may require grounding and/or direct connection to the battery.



118242 - Ford F-150



855151



22551



22114

TOW PLUGS AND FACTORY TOW PACKAGE WIRING HARNESSES

- Vehicle to trailer harness, vehicle specific
- "Factory Appearance"
- Exact replacement for damaged factory wiring harnesses
- Quick and easy installation
- Available with 4-Flat or 7-Way connector
- See application guide for vehicle specific applications

7-WAY U.S. CAR ELECTRICAL CONNECTORS

- Replacement for O.E.M. connectors
- Durable plastic shell
- Weather tight seal
- Use installation bracket 20212
- See application guide for fit information

Part Number	Description	Packaging	Master Carton
85219	7-Way U.S. Car Connector, Car End	Clamshell	3
8551511	7-Way U.S. Car Connector, Car End	Clamshell	3

7-WAY VEHICLE COMPLETE KITS

No other product is designed to specifically deliver everything needed for a fully functional 7-Way, INCLUDING a brake control plug.

No more piecing together products. These kits are custom made and will REDUCE the installation time of installing fully functional 7-Ways.

- The FIRST 7-Way kits that include:
 - Plug & Play connector for the brake control
 - Custom made body harnesses with protective tubing
 - Robust hardwire kit with longer and more cable ties
 - Overload and short circuit protection on Turn/Brake, Tail and Reverse
- See application guide for additional information

Part Number	Description	Packaging	Master Carton
22551	Universal, Works with Multiplex Vehicles, Jacketed Cable, 4.2AMP Backup, 4.2AMP Turn/Stop, 12AMP Tail light	Boxed	3
22111	2008-2012 Buick Enclave, All Styles and 2009-2012 Chevrolet Traverse, All Styles	Boxed	3
22112	2014-2019 RAM ProMaster 1500, 2500, 3500, All Models	Boxed	3
22113	2014-2019 Dodge Durango, All Styles	Boxed	3
22114	2015-2019 Ford Transit 150 and 250, All Styles	Boxed	3
22115	2014-2018 Mercedes Benz Sprinter 2500 and 3500, All Styles	Boxed	3
22116	2015-2019 Ford Transit 350, All Styles	Boxed	3
22117	2016-2019 Toyota Tacoma, All Styles	Boxed	3
22119	2014-2019 Toyota Highlander, All Styles	Boxed	3
22121	2011-2016 Chrysler Town & Country, All Styles, 2011-2018 Dodge Grand Caravan, All Styles and 2012-2015 RAM C/V Tradesman	Boxed	3

ModuLite® POWER MODULES - ULTIMATE VEHICLE PROTECTION

TRAILER LIGHT POWER MODULES

- Virtually eliminates additional electrical draw on the vehicle's tail light circuits
- Ensures maximum trailer light brightness
- Powers the trailer's stop, turn, tail and running lights without overloading vehicle electrical systems
- Compatible with:
 - 2-Wire & 3-Wire systems
 - Multiplex
 - PWM
 - LED tail lights

IDENTIFYING THE NEED FOR MODULITE®

- Today's vehicles have light gauge wire
- Computerized vehicle sensors monitor electrical current draw
- Without ModuLite® the sensors may give false readings
- Adding additional towing lights without ModuLite® may overload the system
- System problems and failure may occur without ModuLite®

HOW IT WORKS

- ModuLite® connects directly to vehicle's battery and powers the towing lights
- ModuLite® provides from 2.1 to 16 amps of power per circuit to the trailer lights, depending on the unit

INSTALLATION

ModuLite® power modules typically install in 30 to 45 minutes depending on the ease of routing the power supply wire from the battery to the rear of the vehicle.

WITH A POWER MODULE the additional power required to supply the trailer lights (represented by the red line) is supplied directly from the battery. Only a small amount of power is required from the fuse panel, turn signal switch, tail light harness and lamp out sensor, to signal when to illuminate the trailer lights.

WITHOUT A POWER MODULE all the additional power required to supply the trailer lights pass through the vehicle's electrical system.

WHEN YOU NEED MODULITE®

- Trailer has more than one light assembly per side and is equipped with multiple clearance or running lights
- If the tow vehicle may tow a variety of different trailers
- Vehicle is equipped with lamp out sensors or other electronic devices that could be damaged by voltage fluctuations
- Owners manuals caution against adding additional loads to electrical circuits

AMP REQUIREMENTS - INCANDESCENT

Bulb Type	Candle Power	Rated Amps	Watts
57 - 1895	2	0.27	3.780
2057	32	2.10	26.880
	2	0.48	6.720
MR16	-	-	35
921	21	1.40	17.920
922	15	0.98	12.544
1141	21	1.44	18.432
93	15	1.04	13.312
105	12	1.07	13.696
1156	32	2.10	26.880
1157	32	2.10	26.880
	3	0.59	8.260
168	3	0.35	4.900
194	2	0.27	3.780

AMP REQUIREMENTS- LED

Stop / Turn	Tail Light / License	SM / CL
0.3	0.05	0.05

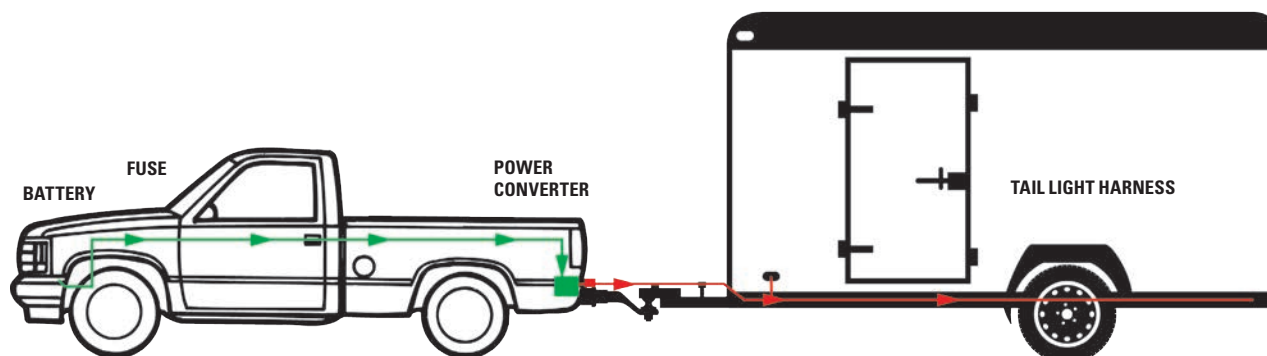



119250

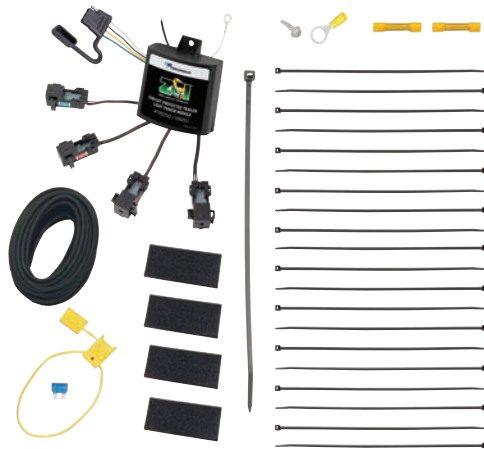

119251

MODULITE® ZCI™ - (ZERO CONTACT INTERFACE)

ZCI™ is the only product in the industry that has ZERO contact with the vehicle's electrical system. Using sensors that easily snap around wires for no direct contact, when electrical current is detected lights are engaged. Our ZCI™ sensors easily snap over wires to detect an electrical current and engage trailer lights -- crucial for high-end vehicles with complex wiring in which snipping, cutting, or splicing voids the vehicle's electrical system warranty. Have a leased vehicle? The ZCI™ is easy to remove without leaving any permanent damage. Take to your next vehicle with the same easy installation.

- Snap, Don't Snip™ – No cutting or splicing vehicle wiring!
- Isolates trailer light operation from the tow vehicle's electrical system
- Eliminates all interference and electrical draw on vehicle's lighting system
- Works with PWM, Multiplexed systems with 2-Wire or 3-Wire hookup and Low side switched vehicles
- Works with all known vehicle wiring systems including D, LS, G and most N codes
- Rated for 4.2 amps for turn/stop and 7.5 amps for tail light trailer circuits
- Robust design allows for interior or exterior mounting
- Don't take the chance of damaging your vehicle. Snipping, cutting, or splicing your wires can lead to:
 - Shorts, damaged wiring and corrosion
 - Blown fuses
 - Warning lights and diagnostic codes
 - Costly and time consuming repairs
 - Expensive dealership code resets

Part Number	Description	Packaging	Master Carton
119250	ModuLite ZCI (Zero Contact Interface)	Litho Box	3
119251	ModuLite ZCI (Zero Contact Interface) with Installation Kit	Litho Box	3



119190



119191

MODULITE® HD PLUS

- Rated for up to 5.0 amps for turns/stops circuits and 7.5 amps for the tail light circuit
- Works on all vehicle types including standard, PWM and/or Multiplex systems
- Integrated, re-settable short circuit and overload protection
- Safeguards itself and the tow vehicle from shorts and installation wiring mishaps
- Draws power directly from the vehicle battery
- Uses less than 5mA of the vehicle circuit for sensing to turn the trailer functions on and off
- Works with either LED or incandescent bulbs (vehicle and trailer)
- The trailer brakes will override the hazard lamps when the brake is activated
- Will not work with vehicles with low-side switch
- All solid-state components in a potted encapsulation

Part Number	Description	Packaging	Master Carton
119190	ModuLite HD Plus	Litho Box	6
119190-012	ModuLite HD Plus, (12 Pack)	Boxed	1
119190-050	ModuLite HD Plus, (50 Pack)	Boxed	1
119191	ModuLite HD Plus with Wiring Kit	Litho Box	6



119147



119148



119177

MODULITE® HD PROTECTOR

- Rated for up to 5.0 amps for turns/stops circuits and 7.5 amps for the tail light circuit
- Has integrated, re-settable short circuit and overload protection
- Safeguards itself and the tow vehicle from shorts and installation wiring mishaps
- The tail light circuit has been upgraded to work with vehicles that use a pulse width modulation (PWM), this ensures full brightness of the trailer lights during operation
- Draws power directly from the vehicle battery
- Uses less than 5mA of the vehicle circuit for sensing to turn the trailer functions on and off
- Works with either LED or incandescent bulbs (vehicle & trailer)
- The trailer brakes will override the hazard lamps when the brake is activated
- Will not work with vehicles with low-side switch or multiplex systems
- Can be used on a 2-Wire or 3-Wire system
- All solid-state components in a potted encapsulation
- Includes integrated protective cover

Part Number	Description	Packaging	Master Carton
119147	ModuLite HD Protector, (Replaces 119179)	Litho Box	12
119147-012	ModuLite HD Protector, (Replaces 119179-012), (12 Pack)	Boxed	1
119147-050	ModuLite HD Protector, (Replaces 119179-050), (50 pack)	Boxed	1
119148	ModuLite HD Protector with Wiring Kit, (Replaces 119180)	Litho Box	6

MODULITE® HD PROTECTOR WITH BACKUP

- Rated for up to 4.2 amps for turns/stops circuits and 7.5 amps for the tail light circuit and 4.2 amps for backup circuit
- Integrated 5-Flat electrical wiring connector. Fifth circuit added for surge brake lockout or backup light circuit on trailers
- Has integrated, re-settable short circuit and overload protection
- Safeguards itself and the tow vehicle from sorts and installation wiring mishaps
- The tail light circuit has been upgraded to work with vehicles that use a pulse width modulation (PWM), this ensures full brightness of the trailer lights during operation
- Draws power directly from the vehicle battery
- Uses less than 5mA of the vehicle circuit for sensing to turn the trailer functions on and off
- Will work with either LED or Incandescent bulbs (vehicle and trailer)
- The trailer brakes will override the hazard lamps when the brake is activated
- Will not work with vehicles with low-side switch or multiplex systems
- Can be used on a 2-Wire or 3-Wire system
- All solid-state components in potted encapsulation
- Includes protective cover

Part Number	Description	Packaging	Master Carton
119177	ModuLite HD Protector with Backup and 5-Flat Connector for Backup Light or Surge Brake Lockout Circuit	Litho Box	12

MODULITE® ULTRA



119192

- Rated for up to 5.0 amps for turns/stops circuits and 16.0 amps for the tail light circuit
- Works on all vehicle types including standard, PWM and/or multiplex systems
- Has integrated, re-settable short circuit and overload protection
- Safeguards itself and the tow vehicle from shorts and installation wiring mishaps
- Draws power directly from the vehicle battery
- Uses less than 5mA of the vehicle circuit for sensing to turn the trailer functions on and off
- Works with either LED or incandescent bulbs (vehicle and trailer)
- The trailer brakes will override the hazard lamps when the brake is activated
- Will not work with vehicles with low-side switch
- All solid-state components in a potted encapsulation

Part Number	Description	Packaging	Master Carton
119192	ModuLite Ultra	Litho Box	12

MODULITE® WIRING KITS

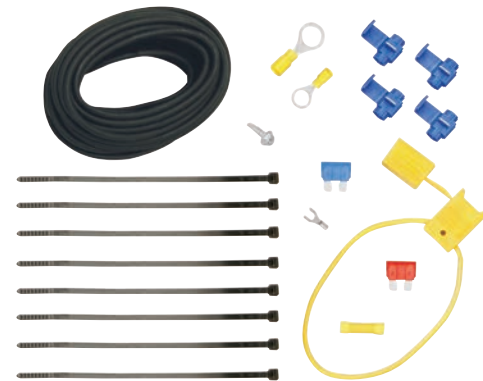

118151

- Upgraded wiring kit for installing all ModuLites
- Includes 20 ft. wire pre-wrapped in conventional tubing

Part Number	Description	Packaging	Master Carton
118150	Upgraded Wiring Kit for Installing all ModuLites, Includes: (1) 20' Wire Pre-Wrapped in Conventional Tubing, (20) 8" Wire Ties, (1) 10 Amp Fuse, (1) 15 Amp Fuse and (1) Weather Sealed Fuse Holder	Clamshell	12
118151	Upgraded Wiring Kit for Installing all ModuLites, Includes: (1) 20' Wire Pre-Wrapped in Conventional Tubing, (8) - 8" Wire Ties, (1) 10 Amp Fuse and (1) Weather Sealed Fuse Holder	Clamshell	6

MULTI-FIT WIRING HARNESSES



20252

- Easy do-it-yourself tow vehicle wiring kits for applications without T-One® Connectors
- 16 gauge wire with 4-Flat dust cover

Part Number	Description	Packaging	Master Carton
20250	Vehicles with Common Turn and Stop Lights and Factory O.E.M. Wiring Harness, 12" Length	Clamshell	12
20251	Vehicles with Separate Turn and Stop Lights and No Factory O.E.M. Wiring Harness. Converter Specification of 2.1 Amps per Stop/Turn Circuit and 4.2 Amps per Tail Circuit, Includes Circuit Tester and 60" Leads	Clamshell	12
20252	Vehicles with Common Turn and Stop Lights and No Factory O.E.M. Wiring Harness, Includes Circuit Tester, 72" Length	Clamshell	12



119178

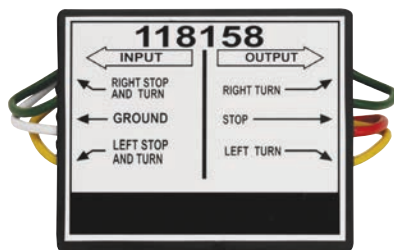

118158



119130



118821

TAIL LIGHT CONVERTER WITH CIRCUIT PROTECTION

- Rated for up to 2.1 amps for turns/stops circuits and 5.6 amps for tail light circuit
- Adapts import and domestic vehicles with separate turn/stop lights (3-Wire system) to standard trailer tail light wiring (2-Wire system)
- Has integrated, re-settable short circuit and overload protection
- Safeguards itself and the tow vehicle from shorts and installation wiring mishaps
- Will work with either LED or incandescent bulbs (vehicle and trailer)
- All solid-state components in potted encapsulation
- Will not work with vehicles with low-side switch or multiplex systems
- Includes integrated protective cover

Part Number	Description	Packaging	Master Carton
119178	Tail Light Converter with 60" 4-Flat Car End Connector	Litho Box	12
119178-012	Tail Light Converter with 60" 4-Flat Car End Connector, (12 Pack)	Boxed	1
119178-050	Tail Light Converter with 60" 4-Flat Car End Connector, (50 Pack)	Boxed	1

2 to 3-WAY TAIL LIGHT CONVERTER

- Allows RV's and other vehicles with 2-Wire systems to tow vehicles and trailers with 3-Wire systems

Part Number	Description	Packaging	Master Carton
118158	Connects a Tow Vehicle with a 2-Wire System to a Towed Vehicle with a 3-Wire System	Clamshell	3

TAIL LIGHT CONVERTER

- Rated for up to 2.1 amps for turns/stops circuits and 7.5 amps for tail light circuit
- Adapts vehicles with separate turn and stop lights (3-Wire system) to standard trailer tail light wiring (2-Wire system)
- Works with either LED or Incandescent bulbs (vehicle and trailer)
- Designed not to send feedback through the vehicle circuits
- All solid-state components
- Will not work with vehicles with low-side switch or multiplex systems
- Includes integrated protective cover

Part Number	Description	Packaging	Master Carton
119130	Tail Light Converter with 60" 4-Flat Car End Connector	Litho Box	12
119130-012	Tail Light Converter with 60" 4-Flat Car End Connector, (12 Pack)	Boxed	1
119130-050	Tail Light Converter with 60" 4-Flat Car End Connector, (50 Pack)	Boxed	1

TAIL LIGHT ISOLATING DIODE SYSTEM

- Allows motorhome to power lights on towed vehicle without power feedback

Part Number	Description	Packaging	Master Carton
118821	Tail Light Isolating System with 4-Flat	Clamshell	3

WESBAR® 4-WAY FLAT WIRE HARNESSSES

- Color coded harnesses in various lengths available with car and trailer end connectors
- Trailer ends can be purchased in straight lengths, loops, wunside or wishbone harness styles



002301

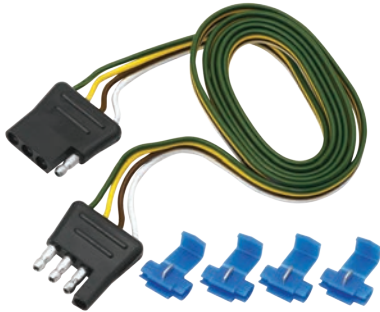

1804401

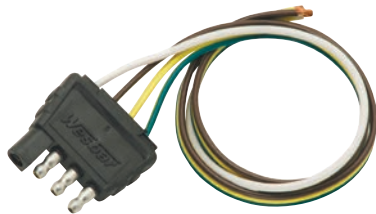

707285

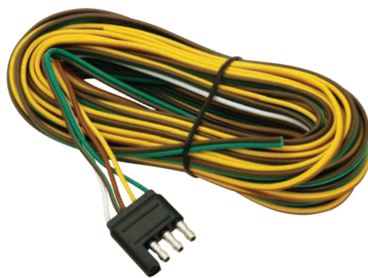

002230



707254

Part Number	Description	Packaging	Master Carton
Car End Harnesses			
002301	4-Flat 48" Car End, 18" Ground	Boxed	300
707275	4-Flat 48" Car End, 18" Ground	Clamshell	12
101469	4-Flat 60" Car End, 6' Ground	Boxed	200
707272	4-Flat 60" Car End, 6' Ground	Clamshell	12
Trailer End Harness			
18004001	4-Flat 12" Trailer End	Boxed	200
Car End and Trailer End Harnesses - Loop Style			
18185001	4-Flat 18" Loop with Wire Taps	Boxed	200
18044001	4-Flat 48" Loop with Wire Taps	Boxed	200
18045001	4-Flat 60" Loop with Wire Taps	Boxed	200
Trailer End Harnesses - Wunside Style			
002401	4-Flat 18" Trailer End, Wunside Harness, 18" Ground	Boxed	300
707285	4-Flat 18" Trailer End, Wunside Harness, 18" Ground	Clamshell	12
002120	4-Flat 20' Trailer End, Wunside Harness, 3' Ground	Boxed	200
002125	4-Flat 25' Trailer End, Wunside Harness, 3' Ground	Boxed	200
002130	4-Flat 30' Trailer End, Wunside Harness, 3' Ground	Boxed	50
Trailer End Harnesses - Wishbone Style			
002402	4-Flat 18" Trailer End, Wishbone Harness, 18" Ground	Boxed	500
707286	4-Flat 18" Trailer End, Wishbone Harness, 18" Ground	Clamshell	12
002215	4-Flat 15' Trailer End, Wishbone Harness, 3' Ground	Boxed	50
002220	4-Flat 20' Trailer End, Wishbone Harness, 3' Ground	Boxed	50
108820	4-Flat 20' Trailer End, Wishbone Harness, 30" Ground	Boxed	50
108825	4-Flat 25' Trailer End, Wishbone Harness, 3' Ground	Boxed	50
707261	4-Flat 25' Trailer End, Wishbone Harness, 3' Ground	Clamshell	6
002230	4-Flat 30' Trailer End, Wishbone Harness, 3' Ground	Boxed	25
108830	4-Flat 30' Trailer End, Wishbone Harness, 3' Ground	Boxed	25
002235	4-Flat 35' Trailer End, Wishbone Harness, 3' Ground	Boxed	25
108835	4-Flat 35' Trailer End, Wishbone Harness, 30" Ground	Boxed	25
002240	4-Flat 40' Trailer End, Wishbone Harness, 3' Ground	Boxed	25
108840	4-Flat 40' Trailer End, Wishbone Harness, 3' Ground	Boxed	25
Trailer End Harnesses with Car Ends - Wishbone Style			
707270	4-Flat 18" Trailer End, Wishbone Harness, 18" Ground with 48" Flat Car End, 18" Ground	Clamshell	12
707103	4-Flat 25' Trailer End, Wishbone Harness Kit with Hardware, 36" Ground with 48" Flat Car End, 18" Ground	Clamshell	6
707104	4-Flat 30' Trailer End, Wishbone Harness Kit with Hardware, 36" Ground with 48" Flat Car End, 18" Ground	Clamshell	6
Double Ended Harness - Extension Style			
707254	Double Ended 4-Flat 24" Cord, 4-Flat Car and Trailer Ends	Clamshell	12

NOTE: Various length and combinations available. Contact your Horizon Global Representative for details. All Tekonsha and Wesbar 4-Way flat wire harnesses conform to SAE J1128 interface specifications

4-WAY FLAT WIRE HARNESSSES

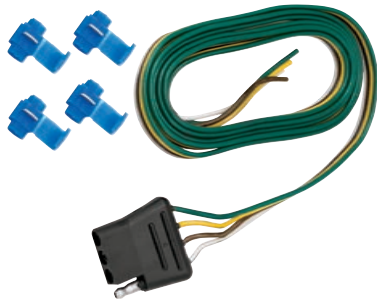

118001



118009

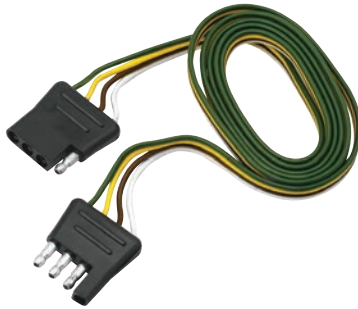

118044

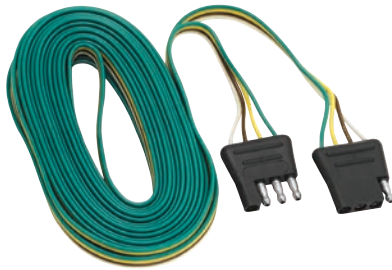

118636



118077

4-WAY FLAT WIRE HARNESSSES

- All 4-Flat wiring conforms to SAE Spec. J1128 assuring you of consistent quality and reliability
- 4-Flat harnesses come in a variety of lengths and packages to fit your every need
- 18 gauge bonded wires
- Tail light, stop and turn functions printed on wire
- Ground wire runs full length of assembly

Part Number	Description	Packaging	Master Carton
Car End Harnesses			
118001	4-Flat 48" Car End, Includes (4) Wire Taps	Clamshell	12
118001-024	4-Flat 48" Car End, (24 Pack)	Boxed	1
118001-200	4-Flat 48" Car End, (200 Pack)	Boxed	1
118002	4-Flat 60" Car End, Includes (4) Wire Taps	Clamshell	12
118002-024	4-Flat 60" Car End, (24 Pack)	Boxed	1
118002-200	4-Flat 60" Car End, (200 Pack)	Boxed	1
118172-024	4-Flat 60" Car End, (24 Pack)	Boxed	1
118172-150	4-Flat 60" Car End, (150 Pack)	Boxed	1
Trailer End Harness			
118004	4-Flat 12" Trailer End	Clamshell	12
118004-012	4-Flat 12" Trailer End, (12 Pack)	Boxed	1
118009	4-Flat 21' Trailer End	Clamshell	6
118033	4-Flat 48" Trailer End	Clamshell	12
118033-012	4-Flat 48" Trailer End, (12 Pack)	Poly Bag	1
118192	4-Flat 25' Trailer End with Dual Tail Light (Brown) Wires	Clamshell	6
Car End and Trailer End Harnesses			
118044	4-Flat 48" Car and Trailer End Loop, Includes (4) Wire Taps	Clamshell	12
118044-010	4-Flat 48" Car and Trailer End Loop, (10 Pack)	Poly Bag	1
118044-175	4-Flat 48" Car and Trailer End Loop, (175 Pack)	Boxed	1
118045	4-Flat 60" Car and Trailer End Loop, Includes (4) Wire Taps	Clamshell	12
118045-010	4-Flat 60" Car and Trailer End Loop, (10 Pack)	Boxed	1
118045-175	4-Flat 60" Car and Trailer End Loop, (175 Pack)	Boxed	1
118636	4-Flat 24' Car and Trailer End Loop	Clamshell	12
118185	4-Flat 18" Car and Trailer End Loop, Includes (4) Wire Taps	Clamshell	3
118185-025	4-Flat 18" Car and Trailer End Loop, (25 Pack)	Poly Bag	1

NOTE: Various length and combinations available. Contact your Horizon Global Representative for details. All Tekonsha and Wesbar 4-Way flat wire harnesses conform to SAE J1128 interface specifications

4-WAY ROUND ELECTRICAL CONNECTORS

- Attractive chrome housing

Part Number	Description	Packaging	Master Carton
118077	4-Way Round Chrome Car End and Trailer End Plug Connectors	Clamshell	12
118101	4-Way Round Chrome Car End Connector	Clamshell	12
118102	4-Way Round Chrome Trailer End Connector	Clamshell	12

118043



4-FLAT CAR END CONNECTORS

- 7.5 amps max per circuit

Part Number	Description	Packaging	Master Carton
118043	30" Car End "Knockout" Socket Connector, 16 Gauge Wire (Un-Bonded), Requires 1-1/4" Hole	Clamshell	12
118603	60" Car End "Knockout" Socket Connector, 16 Gauge Wire (Un-Bonded), Requires 1-1/4" Hole	Clamshell	12

54000-026



4-FLAT / 5-WAY FLAT WIRES HARNESSSES WITH COILED CABLE

- Coiled 14 gauge cable available with either 4-Way or 5-Flat trailer end connectors
- Cable extended length to 11 ft.

Part Number	Description	Packaging	Master Carton
54000-026	4-Way Flat Trailer End with 11' Coiled Cable	Boxed	25
54000-027	5-Way Flat Trailer End with 11' Coiled Cable	Boxed	25

787264



4-WAY FLAT CONNECTORS WITH JACKETED CABLE

- Color coded sealed cable available with trailer end connector, jacketed cable and 4 ft. stripped wire leads
- No exposed wires and sealed for environmental protection

Part Number	Description	Packaging	Master Carton
787264	4-Flat 48" Trailer End with Jacketed Cable	Boxed	50
787268	4-Flat 8' Trailer End with Jacketed Cable	Boxed	25
787270	4-Flat 10' Trailer End with Jacketed Cable	Boxed	20
787274	4-Flat 14' Trailer End with Jacketed Cable	Boxed	20
787159	Double Ended 4-Way Flat 88" Cord, (4-Way Flat Trailer and 4-Square Car Ends)	Boxed	10

85208

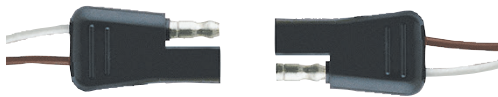

2-WAY FLAT WIRE HARNESS

- Color coded wires
- Molded construction
- Tin plated terminals

Part Number	Description	Packaging	Master Carton
85208	2-Flat Electrical Connector Loop, 12"	Clamshell	6

104393



4-FLAT DUST COVERS

Part Number	Description	Packaging	Master Carton
104393	4-Flat Dust Cover	Boxed	100
85218	4-Way Flat Dust Cover	Clamshell	3
20112-024	4-Way Flat Dust Cover, (24 Pack)	Boxed	1

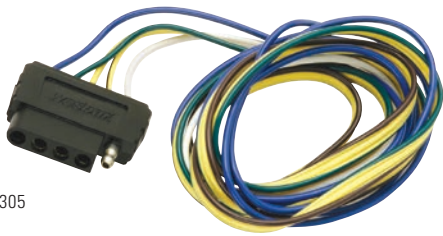

702305

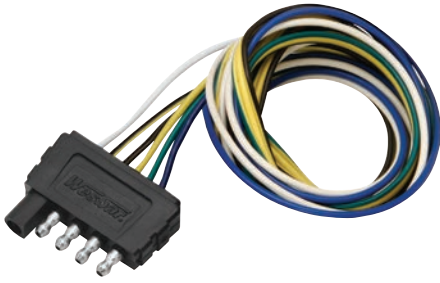

702405



002409



707255



20118

WESBAR® 5-WAY FLAT WIRE HARNESSSES

- Color coded harnesses in various lengths available with car and trailer end connectors
- Trailer ends can be purchased in straight lengths, loops, wunside or wishbone harness styles

Part Number	Description	Packaging	Master Carton
Car End Harnesses			
702305	5-Flat 48" Car End , 18" Ground, 48" Auxiliary	Clamshell	12
002309	5-Flat 60" Car End, 60" Ground, 60" Auxiliary	Boxed	100
707273	5-Flat 60" Car End, 60" Ground, 60" Auxiliary	Clamshell	12
118016	5-Flat 72" Car End	Clamshell	12
118016-025	5-Flat 72" Car End, (25 Pack)	Boxed	1
Trailer End Harness - Wunside Style			
702405	5-Flat 18" Trailer End, Wunside Harness, 18" Ground, 18" Auxiliary	Clamshell	12
Trailer End Harnesses - Wishbone Style			
118017	5-Flat 48" Trailer End, Wishbone Harness	Clamshell	12
002409	5-Flat 48" Trailer End, Wishbone Harness, 48" Ground, 48" Auxiliary	Boxed	100
707283	5-Flat 48" Trailer End, Wishbone Harness, 48" Ground, 48" Auxiliary	Clamshell	12
002275	5-Flat 25' Trailer End, Wishbone Harness, 48" Ground, 60" Auxiliary	Boxed	25
702275	5-Flat 25' Trailer End, Wishbone Harness, 48" Ground, 60" Auxiliary	Clamshell	6
002280	5-Flat 30' Trailer End, Wishbone Harness, 48" Ground, 60" Auxiliary	Boxed	25
002285	5-Flat 35' Trailer End, Wishbone Harness, 48" Ground, 60" Auxiliary	Boxed	25
002290	5-Flat 40' Trailer End, Wishbone Harness, 48" Ground, 60" Auxiliary	Boxed	25
Trailer End Harnesses with Car End - Wishbone Style			
707105	5-Flat 25' Trailer End, Wishbone Harness Kit with Hardware, 48" Ground, 60" Auxiliary with 72" Car End, 72" Ground, 72" Auxiliary	Clamshell	6
Double Ended Harnesses - Extension Style			
707255	Double End 5-Way 24" Cord, 5-Flat Car and Trailer Ends	Clamshell	12
118215	Double End 5-Way 72" Cord, 5-Flat Car and Trailer Ends	Clamshell	12

NOTE: Various length and combinations available. Contact your Horizon Global Representative for details

5-FLAT DUST COVERS

Part Number	Description	Packaging	Master Carton
20118	5-Way Flat Dust Cover	Clamshell	6
20118-024	5-Way Flat Dust Cover, (24 Pack)	Boxed	1



118036



118037

6-WAY METAL CONNECTORS

- Heavy duty die cast corrosion resistant housing, spring loaded car end cover, and coded terminals
- Interchangeable with other standard 6-Way connectors

Part Number	Description	Packaging	Master Carton
62	6-Way Metal Car End Only	Boxed	50
63	6-Pin Metal Trailer End Only	Boxed	50
118036	6-Pin Heavy Duty Metal Car End Socket Connector	Clamshell	6
118036-006	6-Pin Heavy Duty Metal Car End Socket Connector, (6 Pack)	Poly Bag	1
118036-050	6-Pin Heavy-Duty Metal Car End Socket Connectors, (50 Pack)	Boxed	1
118037	6-Pin Heavy-Duty Metal Trailer End Plug Connectors	Clamshell	12
118037-006	6-Pin Heavy-Duty Metal Trailer End Plug Connectors, (6 Pack)	Poly Bag	1
118037-050	6-Pin Heavy-Duty Metal Trailer End Plug Connectors, (50 Pack)	Boxed	1

6-SQUARE WIRE HARNESSES

- Used on tent trailers



118104

Part Number	Description	Packaging	Master Carton
30105	6-Way Square Connector Set, Male and Female Ends, 12"	Clamshell	12
118104	6-Square to 4-Flat Adapter, 12" Loop	Poly Bag	10

6-WAY SUPER SEALED CAR END WITH CABLE

- Pre-Wired, 6-Way car end sealed with 2 ft., 4 ft. or 7 ft. of UL listed 6-Pin cable (white/blue/red - 10 ga.; yellow/brown/green 14 - ga.)
- Solid brass terminals and housing of industrial-strength, glass-filled thermoplastic, door with EPDM rubber gasket and heavy duty stainless steel spring
- Manufactured with UL listed PVC for flexibility and features molded construction to encapsulate terminals and wires



50-86-004

Part Number	Description	Packaging	Master Carton
50-86-004	6-Pin Super Sealed Car End with 4' Cable	Boxed	10
50-86-007	6-Pin Super Sealed Car End with 7' Cable	Boxed	10

6-WAY PIN MOLDED TRAILER END CONNECTORS WITH CABLE

- 6-Pin heavy duty series molded connectors
- Can be purchased with 3-10 gauge and 3-14 gauge wires (primary wire gauges; yellow/brown/green - 14 ga.) or 6-14 gauge wires
- Both models feature encapsulated terminals and wires to form one weather resistant, non-corrosive assembly
- Can be used with thermoplastic or metal 6-Pin car end connectors



50-61-008

Part Number	Description	Packaging	Master Carton
50-61-008	6-Way Molded Trailer Cord with 8' Cable, 3-10 Gauge, 3-14 Gauge	Boxed	10
50-61-104	6-Way Molded Trailer Cord with 4' Cable, 6-14 Gauge	Boxed	10
50-61-106	6-Pin Molded Trailer Cord with 6' Cable, 6-14 Gauge	Boxed	10
50-61-108	6-Pin Molded Trailer Cord with 8' Cable, 6-14 Gauge	Boxed	10

NOTE: Various length and combinations available. Contact your Horizon Global Representative for details



50-77-003



50-77-001

7-WAY THERMO-PLASTIC CONNECTORS

- 12-volt thermoplastic connector with brass contact to prevent corrosion
- Built-in cable clamp prevents wear on 7-Way cable
- Unique method of forming contact pins provides for easy connecting and disconnecting

Part Number	Description	Packaging	Master Carton
50-77-001	7-Way Plastic Car End Only	Bulk	50
54-77-001	7-Way Plastic Car End Only	Poly Bag	25
50-77-003	7-Way Plastic Trailer End Only	Bulk	50
54-77-003	7-Way Plastic Trailer End Only	Poly Bag	25



50-57-007

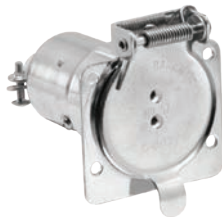

50-57-503

7-WAY METAL CONNECTORS

- 12-volt metal connector with plastic core
- Metal housing is 20 gauge steel, zinc plated to protect against corrosion
- Trigger grip for easy disconnection

Part Number	Description	Packaging	Master Carton
50-57-503	7-Way Metal Car End Only	Bulk	50
54-57-503	7-Way Metal Car End Only	Poly Bag	25
50-57-007	7-Way Metal Trailer End Only	Bulk	50
54-57-007	7-Way Metal Trailer End Only	Poly Bag	25



118021



118030

7-WAY STANDARD CONNECTORS

- Non-corroding brass terminals
- Built in strain relief keeps wire secured to terminals
- Designed for 12 volt systems
- Flat style contact pins mean easy, positive connecting and disconnecting
- Designed for RV trailers
- Available with metal or plastic shell

Part Number	Description	Packaging	Master Carton
118020-006	7-Way Plastic Car End Socket Connector, (6 Pack)	Boxed	1
118020-050	7-Way Plastic Car End Socket Connector, (50 Pack)	Boxed	1
118021	7-Way Plastic Trailer End Plug Connector	Clamshell	12
118021-006	7-Way Plastic Trailer End Plug Connector, (6 Pack)	Boxed	1
118021-050	7-Way Plastic Trailer End Plug Connector, (50 Pack)	Boxed	1
118030	7-Way Metal Car End Socket Connector	Clamshell	8
118031	7-Way Metal Trailer End Plug Connector	Clamshell	12



50-87-002

7-WAY SUPER SEALED CAR ENDS WITH CABLE

- Pre-Wired 7-Way car end sealed with 2 ft., 4 ft., 7 ft. or 9 ft. of UL listed 7-Way cable
- Solid brass terminals, housing of industrial-strength, glass-filled thermoplastic, door with EPDM rubber gasket and heavy duty stainless steel spring
- Manufactured with UL listed PVC for flexibility and features molded construction to encapsulate terminals and wires

Part Number	Description	Packaging	Master Carton
50-87-002	7-Way Super Sealed Car End with 2' Cable	Bulk	10
51-87-002	7-Way Super Sealed Car End with 2' Cable	Clam	10
50-87-004	7-Way Super Sealed Car End with 4' Cable	Bulk	10
50-87-007	7-Way Super Sealed Car End with 7' Cable	Bulk	10
50-87-009	7-Way Super Sealed Car End with 9' Cable	Bulk	5



002478

7-WAY MOLDED CONNECTOR WITH CABLE TRAILER END

- 7-Way plastic trailer connector molded to heavy duty 7-Way insulated cable. Made with self-cleaning contacts and molded to encapsulate terminals and wires to form one weather resistant, non-corrosive assembly
- Primary wire gauges; black/white-10 ga., blue-12 ga., brown/red/green/yellow-14 ga.
- Molded connector can be used with thermoplastic or metal 7-Way car end connectors

Part Number	Description	Packaging	Master Carton
002478	7-Way Molded Trailer End with 8' Cable	Bulk	10



50-67-410

7-WAY MOLDED TRAILER END WITH CABLE AND BREAKAWAY SWITCH

Part Number	Description	Packaging	Master Carton
50-67-410	7-Way Molded Trailer End with 10' Cable and Breakaway Switch	Bulk	10



50-67-901

7-WAY DOUBLE ENDED MOLDED TRAILER END WITH CABLE

Part Number	Description	Packaging	Master Carton
50-67-901	Double Ended 7-Way Molded Trailer Cord with 6' Cable	Bulk	10
50-67-210	Double Ended 7-Way Molded Trailer Cord with 8' Cable	Bulk	10

NOTE: Various length and combinations available. Contact your Horizon Global Representative for details



50-67-002

7-WAY MOLDED TRAILER END CONNECTORS WITH CABLE - RV CLOCKING

- 7-Way plastic trailer connector molded to heavy duty 7-Way insulated cable
- Made with self-cleaning contacts and molded to encapsulate terminals and wires to form one weather resistant, non-corrosive assembly
- Primary wire gauges within the insulated cable; black/white-10 ga., blue-12 ga., brown/red/green/yellow-14 ga.
- Molded connector can be used with thermoplastic or metal 7-Way car end connectors



8549100

Part Number	Description	Packaging	Master Carton
50-67-907	7-Way Molded Trailer Cord with 4' Cable	Boxed	10
50-67-001	7-Way Molded Trailer Cord with 6' Cable	Boxed	10
50-67-002	7-Way Molded Trailer Cord with 7' Cable	Boxed	10
50-67-003	7-Way Molded Trailer Cord with 8' Cable	Boxed	10
51-67-003	7-Way Molded Trailer Cord with 8' Cable	Clamshell	10
50-67-004	7-Way Molded Trailer Cord with 9' Cable	Boxed	10
50-67-005	7-Way Molded Trailer Cord with 10' Cable	Boxed	10
50-67-007	7-Way Molded Trailer Cord with 12' Cable	Boxed	10
50-67-103	7-Way Molded Trailer Cord with 15' Cable	Boxed	5
50-67-106	7-Way Molded Trailer Cord with 18' Cable	Boxed	5
8549100	7-Way Molded Trailer Cord with 6' Cable, Blade Style	Display Card	3



54-67-525

7-WAY MOLDED TRAILER END CONNECTOR REPLACEMENT KIT - RV CLOCKING

- Easy to install, complete with instructions
- Features self cleaning contacts, one foot of cable, butt connectors and weather resistant shrink tubing

Part Number	Description	Packaging	Master Carton
54-67-525	7-Way Molded Trailer End Connector Replacement Kit with 12" Cable	Poly Bag	5

7-WAY CONNECTORS - RV CLOCKING

- Standard 7-Way cable
- Coiled application prevents sagging wires
- Easy termination

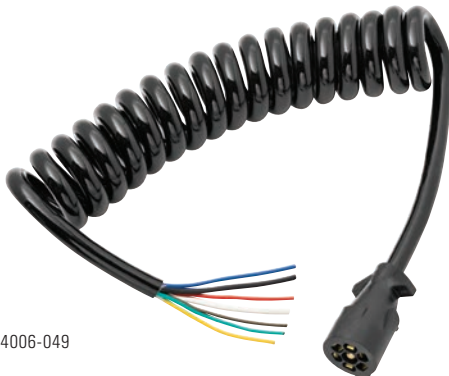

54006-049

Part Number	Description	Packaging	Master Carton
54006-043	Coiled 7-Way Molded Trailer Connector, 6'	Poly Bag	4
54006-049	Coiled 7-Way Molded Trailer Connector, 6'	Boxed	3
54006-044	Coiled 7-Way Molded Trailer Connector, 8'	Poly Bag	4
54006-050	Coiled 7-Way Molded Trailer Connector, 8'	Boxed	3
54006-045	Coiled 7-Way Molded Trailer Connector, 10'	Poly Bag	4
54006-051	Coiled 7-Way Molded Trailer Connector, 10'	Boxed	3
54006-046	Coiled 7-Way Molded Trailer Connector, 12'	Poly Bag	4
54006-052	Coiled 7-Way Molded Trailer Connector, 12'	Boxed	3

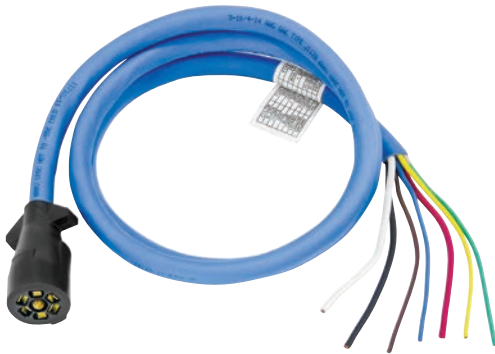

54006-057

7-WAY HEAVY DUTY MOLDED TRAILER CONNECTORS WITH INSULATED CABLE

- 7-Way trailer connector molded to cold environment heavy duty blue silicon 7-Way insulated cable (rated to -55°C/-67°F)
- Made with self-cleaning contacts and molded to encapsulate terminals and wires to form one weather resistant, non-corrosive assembly
- Primary wire gauges within the insulated cable; black/white/red-10 ga., blue/brown/green/yellow-14 ga.
- Molded connector can be used with thermoplastic or metal 7-Way car end connectors

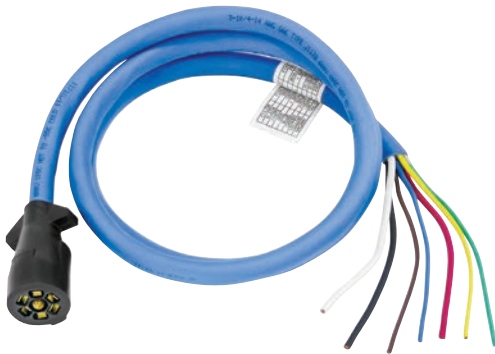

54006-016

Part Number	Description	Packaging	Master Carton
54006-057	7-Way Cold Weather Molded Trailer Cord with 6' Cable, RV Clocking	Poly Bag	10
54006-058	7-Way Cold Weather Molded Trailer Cord with 8' Cable, RV Clocking	Poly Bag	10
54006-059	7-Way Cold Weather Molded Trailer Cord with 10' Cable, RV Clocking	Poly Bag	10
54006-009	7-Way Cold Weather Molded Trailer Cord with 6' Cable	Poly Bag	10
54006-010	7-Way Cold Weather Molded Trailer Cord with 8' Cable	Poly Bag	10
54006-015	7-Way Cold Weather Molded Trailer Cord with 10' Cable	Poly Bag	10
54006-016	7-Way Cold Weather Molded Trailer Cord with 12' Cable	Poly Bag	10

NOTE: Various length and combinations available. Contact your Horizon Global Representative for details. Reference wiring diagrams for pin locations

7-WAY MOLDED TRAILER CONNECTORS WITH CABLE - TRAILER CLOCKING

- 7-Way plastic connector molded to heavy duty 7-Way insulated cable using trailer clocking
- Provides 7-Way connector contact color coding more conducive to horse and livestock trailers versus RV trailers
- Made with self-cleaning contacts and molded to encapsulate terminals and wires to form one weather resistant, non-corrosive assembly
- Permits the trailer to have the clean appearance and environmental advantages of a sealed, molded 7-Way cord
- Primary wire gauges within the insulated cable; black/white-10 ga., blue-12 ga., brown/red/green/yellow-14 ga.



50-67-614

Part Number	Description	Packaging	Master Carton
50-67-614	7-Way Molded Trailer Cord with 4' Cable	Boxed	10
50-67-616	7-Way Molded Trailer Cord with 6' Cable	Boxed	10
50-67-618	7-Way Molded Trailer Cord with 8' Cable	Boxed	10
50-67-620	7-Way Molded Trailer Cord with 10' Cable	Boxed	10

NOTE: Various length and combinations available. Contact your Horizon Global Representative for details. Crimped junction box terminals can be added. Reference wiring diagrams for pin locations



118664

7-WAY / 6-PIN TRAILER EXTENSIONS

Part Number	Description	Packaging	Master Carton
118666	6-Pin Connector Extension Cable, 7'	Poly Bag	25
118664	7-Way Connector Extension Cable, 7'	Poly Bag	25



20223

USCAR 7-WAY PRE-WIRED CABLES FOR HOOK-UP OF FIFTH WHEEL AND GOOSENECK TRAILERS

- Allows remote wiring in pickup beds or other hard to access areas when towing a fifth wheel or gooseneck trailer, using an OEM USCAR connector
- Features durable plastic housing with weather tight seal

Part Number	Description	Packaging	Master Carton
20224	USCAR 7-Way Connector with 4' Cable	Clamshell	12
20223	USCAR 7-Way Connector with 7' Cable	Clamshell	12

NOTE: See application guide for vehicle specific applications



50-97-407

90° 7-WAY PRE-WIRED CABLES FOR HOOK-UP OF FIFTH WHEEL AND GOOSENECK TRAILERS

- 7-Way 90° connector molded to heavy duty 7-Way insulated cable for fifth wheel or gooseneck trailer applications
- Allows remote wiring in pickup beds or other hard to access areas
- 90° molded from flame retardant material
- Features a patented mounting bracket that allows for installation in virtually all pickup models and styles and includes self-tapping stainless steel mounting screws
- Manufactured with UL listed 10/2, 12/1 and 14/4 jacketed cable

Part Number	Description	Packaging	Master Carton
50-97-407	90° 7-Way Molded Trailer Cord with 7' Cable	Boxed	10
54700-010	Screw Kit for Aluminum Beds, 4 Per Bag	Boxed	50



20129

PRE-WIRED CABLES FOR HOOK-UP OF FIFTH WHEEL AND GOOSENECK TRAILERS

- Allows remote wiring in pickup beds or other hard to access areas when towing a fifth wheel or gooseneck trailer, upgrading from OEM wiring

Part Number	Description	Packaging	Master Carton
20128	4-Flat (OEM) to 6-Way Connector Kit with 7' Cable	Clamshell	12
20129	4-Flat (OEM) to 6-Way Connector Kit with 7' Cable	Clamshell	12
20131	4-Flat (OEM) to 7-Way Connector Kit with 7' Cable	Clamshell	12
20140	Fifth Wheel Adapter Harness, 7-Way Flat Pin USCAR Connector Assembly with 7' Cable with Pigtails for Choice of Hardwiring 6-Way or 7-Way Connector, GM, Ford, Dodge and Toyota	Clamshell	3

NOTE: See application guide for vehicle specific applications



20140



20110

USCAR VEHICLE SPECIFIC COMPLETE KITS

Part Number	Description	Packaging	Master Carton
20110	USCAR 7-Way Complete Connector Kit with 7' Cable, Dodge, Ford, GM, RAM and Toyota	Clamshell	3
20111	USCAR 7-Way Complete Connector Kit with 7' Cable, Dodge RAM 1500/2500/3500 00-09	Clamshell	3
20113	USCAR 7-Way Complete Connector Kit with 7' Cable, Toyota Tundra 07-09	Clamshell	3
20146	Fifth Wheel Adapter Harness, 7-Way Flat Pin U.S. Car Connector Assembly 9', Dodge, Ford, GM, RAM and Toyota	Clamshell	6
20147	USCAR 7 Way Replacement Harness 18.25"	Clamshell	12



54700-004

90° VEHICLE SPECIFIC COMPLETE KITS

Part Number	Description	Packaging	Master Carton
50-97-410	90° 7-Way Complete Connector Kit with 9' Cable	Poly Bag	10
50-97-411	90° 7-Way Complete Connector Kit with 9' Cable	Poly Bag	10
50-97-412	90° 7-Way Complete Connector Kit with 9' Cable	Poly Bag	10
54700-003	90° 7-Way Complete Connector Kit with 7' Cable	Poly Bag	10
54700-004	90° 7-Way Complete Connector Kit with 7' Cable	Poly Bag	10
54700-007	90° 7-Way Complete Connector Kit with 7' Cable	Poly Bag	10
54700-009	90° 7-Way Complete Connector Kit with 9' Cable	Poly Bag	10

NOTE: See application guide for vehicle specific applications

7-WAY 90° PRE-WIRED CABLE APPLICATION CHART

Make/Model	Style	Years	Position	7 ft. Clamshell	9 ft. Clamshell	90°/9 ft. Bulk	90°/7 ft. Bulk
CHEVROLET/GMC							
Silverado/Sierra 1500	with Factory 7-Way	99 - 19	PU3	20110	20146	50-97-410	54700-003
Silverado/Sierra 1500 HD	(Classic), with Factory 7-Way	01 - 07	PU3	20110	20146	50-97-410	54700-003
Silverado/Sierra 2500	with Factory 7-Way	99 - 04	PU3	20110	20146	50-97-410	54700-003
Silverado/Sierra 2500 HD	with Factory 7-Way	01 - 19	PU3	20110	20146	50-97-410	54700-003
Silverado/Sierra 3500	(Classic), with Factory 7-Way	01 - 07	PU3	20110	20146	50-97-410	54700-003
Silverado/Sierra 3500 HD	with Factory 7-Way	07 - 19	PU3	20110	20146	50-97-410	54700-003
DODGE/RAM							
Ram 1500	with Factory 7-Way	00 - 08	PU3	20111		50-97-411	
Ram 1500	with Factory 7-Way	09 - 19	PU3	20110	20146	50-97-410	54700-003
Ram 2500	with Factory 7-Way	00 - 09	PU3	20111		50-97-411	
Ram 2500	with Factory 7-Way	10 - 19	PU3	20110	20146	50-97-410	54700-003
Ram 3500	with Factory 7-Way	00 - 09	PU3	20111		50-97-411	
Ram 3500	with Factory 7-Way	10 - 19	PU3	20110	20146	50-97-410	54700-003
FORD							
F-150	with Factory 7-Way	97 - 18	PU3	20110	20146	50-97-410	54700-003
F-250	Styleside, with Factory 7-Way	97 - 99	PU3	20110	20146	50-97-410	54700-003
F-250/350 Super Duty	with Factory 7-Way	99 - 10	PU3	20110	20146	50-97-410	54700-003
F-250/350 Super Duty	with Factory 7-Way	11 - 19	PU3	20110	20146	54700-009	54700-007
F-450 Super Duty	with Factory 7-Way	99 - 10	PU3	20110	20146	50-97-410	54700-003
F-450 Super Duty	with Factory 7-Way	11 - 19	PU3	20110	20146	54700-009	54700-007
F-550 Super Duty	with Factory 7-Way	99 - 11	PU3	20110	20146	50-97-410	54700-003
LINCOLN							
Mark LT	with Factory 7-Way	06 - 08	PU3	20110	20146	50-97-410	54700-003
NISSAN							
Titan	with Factory 7-Way	04 - 14	PU3	20110	20146	50-97-410	54700-003
TOYOTA							
Tundra	with Factory 7-Way	07 - 09	PU3	20113		50-97-412	54700-004
Tundra	with Factory 7-Way	10 - 19	PU3	20110	20146	50-97-410	54700-003

BRAKE MATE™ 7-WAY PRE-WIRED ADAPTER KIT



118607

- Includes all necessary parts required to completely install all brake controls. No other parts are necessary
- Each Brake Mate™ Kit includes:
 - (1) Pre-Wired 7-Way round connector
 - (5) Scotch locks
 - (1) 4-Flat trailer end
 - (7) Ring connectors
 - (1) Heavy-duty flasher
 - (8) Self tapping screws
 - (2) Heavy-duty breakers
 - (6) Tie straps

Part Number	Description	Packaging	Master Carton
118607	7-Way Flat Pin Brake Mate Kit, with Brake Control Wiring Installation Kit	Clamshell	12



20320

7-WAY AND 6-PIN ELECTRICAL ADAPTERS

- Used to convert any trailer wiring component, T-One® Connector or tail light converter with a 4-Flat trailer end connector to a 6-Way or 7-Way round connector
- For simple mounting, choose 6-Way and 7-Way mounting box part numbers 118156, 118157 or 118159 (sold separately)

Part Number	Description	Packaging	Master Carton
20320	4-Flat To 6-Pin Connector, Metal	Clamshell	12
20320-012	4-Flat To 6-Pin Connector, Metal, (12 Pack)	Boxed	1
74184	4-Flat to 7-Way Connector, Plastic	Clamshell	3
20321-012	4-Flat To 7-Way Connector, Plastic (12 Pack)	Boxed	1
20322	4-Flat To 7-Way Flat Pin Connector, Metal	Clamshell	12
20125	4-Flat To 7-Way Flat Pin U.S. Car Connector, Plastic	Clamshell	12



20321-012

7-WAY PRE-WIRED ADAPTER

- Used to convert any trailer wiring component, T-One® Connector or tail light converter with a 4-Flat trailer end connector to a 7-Way round connector
- Each kit includes 20 ft. of wire
- For simple mounting, choose 7-Way mounting box part numbers 118156, 118157 or 118159 (sold separately)



118799

Part Number	Description	Packaging	Master Carton
118799	7-Way Connector with Pre-Wired Brake Wire	Clamshell	12



787305

AG 7-PIN ROUND CONNECTORS

- A discrete round 7-Pin vehicle and implement connector for AG OEM and aftermarket use
- Vehicle side connector includes a mountable storage box
- Implement side connector includes a metal spring cable relief

Part Number	Description	Packaging	Master Carton
787305	AG 7-Pin Round Pin AG Vehicle Connector	Boxed	10
787303	AG 7-Pin Round Pin AG Vehicle Connector	Clamshell	6
787304	AG 7-Pin Round Pin AG Trailer Connector	Boxed	10
787302	AG 7-Way Round Pin AG Trailer Connector	Clamshell	6



787302

AG 7-WAY MOLDED TRAILER CONNECTORS WITH CABLE - TRAILER CLOCKING

- 7-Way plastic connector molded to heavy duty 7-Way insulated cable using trailer clocking
- Provides 7-Way connector contact color coding more conducive to horse and livestock trailers versus RV trailers
- Made with self-cleaning contacts and molded to encapsulate terminals and wires to form one weather resistant, non-corrosive assembly
- Permits the trailer to have the clean appearance and environmental advantages of a sealed, molded 7-Way cord
- Primary wire gauges within the insulated cable; black/white-10 ga., blue-12 ga., brown/red/green/yellow-14 ga.



50-67-614

Part Number	Description	Packaging	Master Carton
50-67-614	AG 7-Way Molded Trailer Cord with 4' Cable	Boxed	20
50-67-616	AG 7-Way Molded Trailer Cord with 6' Cable	Boxed	15
50-67-618	AG 7-Way Molded Trailer Cord with 8' Cable	Boxed	10
50-67-620	AG 7-Way Molded Trailer Cord with 10' Cable	Boxed	10

NOTE: Various length and combinations available. Contact your Horizon Global Representative for details. Crimped junction box terminals can be added. Reference wiring diagrams for pin locations



002500

AG TANDEM HAUL ADAPTERS

- Allows implements to be towed in tandem, providing versatility and economy

Part Number	Description	Packaging	Master Carton
002500	AG Tandem Haul Adapter	Poly Bag	1
002625	AG Tandem Haul Kit	Boxed	1

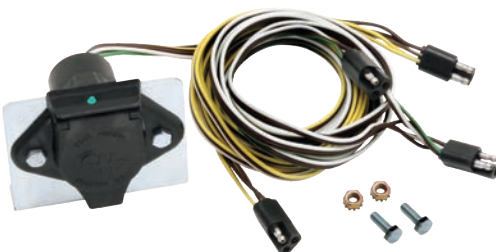

002625

002415



002505



108318



54003-017



105728



AG EXTENSION HARNESSSES

- Install on towable field implements to bring power from the tractor to AG Lights
- Full length ground assures reliable and continuous operation
- Custom configurations and lengths available

Part Number	Description	Packaging	Master Carton
002510	AG 10' Heavy-Duty Wishbone Harness	Boxed	25
002408	AG 5' Economy Extension Harness	Boxed	100
002410	AG 10' Economy Extension Harness	Boxed	50
002415	AG 15' Straight Section Harness with 7-Pin AG Plug and Flat 4-Way	Boxed	15
002425	AG 25' Straight Section Harness with 7-Pin AG Plug and Flat 4-Way	Boxed	5
002430	AG 30' Straight Section Harness with 7-Pin AG Plug and Flat 4-Way	Boxed	5
002435	AG 35' Extension Harness	Boxed	5
002504	AG 10' Economy Rear Wishbone Harness	Boxed	50
002505	AG 15' Economy Rear Wishbone Harness	Boxed	50
002515	AG 15' Heavy-Duty Rear Wishbone Harness	Boxed	15

AG LIGHT ENHANCED LIGHTING MODULES

- Install to meet the enhanced lighting standard and have a dramatic safety feature to better signal turns by tractors and implements

Part Number	Description	Packaging	Master Carton
54500-001	Module with Wire Leads	Poly Bag	25
108318	Module with Molded Plugs	Boxed	50
54500-002	Module with Brake Light Signal Function with Wire Leads	Boxed	25

AG REPAIR HARNESSSES

Part Number	Description	Packaging	Master Carton
54003-017	AG Repair Harness, 4 Wire with 4-Way Square Connector	Boxed	5
54003-018	AG Repair Harness, 4 Wire with 4-Way Square Connector	Boxed	5

AG 7-WAY PLUG HOLDER

Part Number	Description	Packaging	Master Carton
105728	Plug Holder for AG 7-Way Round Pin Trailer Connector Trailer End	Boxed	50

VEHICLE / TRAILER ADAPTERS

- Adapters for a quick switch from one style plug to another when towing multiple trailers

118700



118704-050



118703



20142



51-20036



Part Number	Description	Packaging	Master Carton
20136	4-Flat To 5-Flat Adapter	Clamshell	12
118601	4-Flat Knockout Adapter	Clamshell	12
50-98-054	6-Pin Round Pin to 4-Way Flat	Boxed	200
707281	6-Pin Round Pin to 4-Way Flat	Clamshell	6
118700	6-Pin Round To 4-Flat Adapter	Boxed	-
118700-050	6-Pin Round To 4-Flat Adapter, (50 Pack)	Boxed	1
50-98-050	7-Way Blade to 4-Way Flat	Boxed	150
54-98-050	7-Way Blade to 4-Way Flat	Poly Bag	25
707282	7-Way Blade to 4-Way Flat	Clamshell	6
50-98-052	7-Way Round Pin to 4-Way Flat	Boxed	125
54-98-052	7-Way Round Pin to 4-Way Flat	Poly Bag	25
767940	7-Way Blade to 5-Way Flat	Clamshell	6
007257	7-Way Blade to 5-Flat, 6" Wire	Clamshell	12
707250	7-Way Blade to 5-Flat, 18" Wire	Clamshell	6
50-98-051	7-Way Blade to 6-Pin Round Pin (Auxiliary in Center)	Boxed	150
54-98-051	7-Way Blade to 6-Pin Round Pin (Auxiliary in Center)	Poly Bag	25
74607	7-Way Flat Pin To 4-Flat Adapter	Clamshell	3
118702-050	7-Way Flat Pin To 4-Flat Adapter, (50 Pack)	Boxed	1
118709	7-Way Round Pin To 4-Flat Adapter	Clamshell	12
118710	7-Way European Style Round Pin to 4-Flat Adapter	Boxed	10
85216	7-Way To 6-Pin Adapter, Electric Brakes To Outer Pin (S)	Clamshell	3
118704-050	7-Way To 6-Pin Adapter, Electric Brakes To Outer Pin (S), (50 Pack)	Boxed	1
74645	7-Way To 6-Pin Adapter, Electric Brakes To Center Pin (A)	Clamshell	3
118708-050	7-Way To 6-Pin Adapter, Electric Brakes To Center Pin (A), (50 Pack)	Boxed	1
118703	7-Way To 5-Flat Adapter	Boxed	6

LAMP OUT BY-PASS VEHICLE ADAPTERS

- Adapters with LED lamp out by-pass for European vehicles

Part Number	Description	Packaging	Master Carton
20141	7-Way Flat Pin to 5-Flat Adapter with LED Lamp Out By-Pass	Clamshell	12
20142	7-Way Flat Pin to 7-Flat Adapter with LED Lamp Out By-Pass	Clamshell	12

STANDARD VEHICLE / TRAILER ADAPTER

- Step-up style

Part Number	Description	Packaging	Master Carton
51-20036	4-Flat to 5-Flat	Clamshell	12

DUAL PART VEHICLE / TRAILER ADAPTER

- Step-up style

Part Number	Description	Packaging	Master Carton
85343	4-Flat to 4-Flat and 7-Way	Clamshell	3

118019



CIGARETTE LIGHTER ADAPTER

- Provides 12v power at rear of vehicle for travel accessories
- Ideal for power inverter hook-up
- Great for tailgating

Part Number	Description	Packaging	Master Carton
118019	7-Way to Cigarette Lighter Plug Adapter	Clamshell	12

78007



RETRACTABLE WIRING ADAPTER

- Converts 7-Way round blade connector to standard 4-Way flat connector
- Adjust length up to 42 in., no wires dragging on the ground
- Retractable 4-Way flat car end plug connects with standard 4-Way flat trailer end plug
- Adapts to factory 7-Way blade receptacle
- Protects and stores when not in use

Part Number	Description	Packaging	Master Carton
78007	7-Way to 4-Way Flat	Display Card	3

78118



ADAPTER WITH LED CIRCUIT TESTER

- Easily adapt OEM 7-Way blade connector to either 5-Flat or a 4-Flat connector
- Instantly checks electrical circuit for connectivity
- Displays connectivity using high visibility LEDs
- Attached dust cover included to keep terminals clean when not towing a trailer
- Patent pending

Part Number	Description	Packaging	Master Carton
78118	7-Way Blade to 4 or 5-Flat with LED Circuit Tester	Clamshell	3



78117



ADAPTER WITH TOW-GLO

- Easily adapt OEM 7-Way blade connector to basic 4-Flat connector
- Glows RED when tail light circuit is activated assisting with seeing connection in low light
- Attached dust cover included to keep terminals clean when not towing a trailer

Part Number	Description	Packaging	Master Carton
78117	7-Way Blade to 4-Flat with Tow-Glo	Clamshell	3

787207



VEHICLE / TRAILER COILED ADAPTERS

- Environmentally sealed 16 gauge coiled wire prevents tangling
- Attractive marine yellow, no fade color
- 7-Way mates with OE style 7-Way blade connectors
- 5-Way mates with either a 4-Way or 5-Way flat connector

Part Number	Description	Packaging	Master Carton
787206	5-Flat Coiled Jumper with 4' Cable, 5-Way Flat Car and Trailer Ends	Boxed	20
787207	7-Way Trailer to 5-Flat Car End Coiled Jumper with 4' Cable	Boxed	20
787208	7-Way Trailer to 5-Way Flat Car End Coiled Jumper with 8' Cable	Boxed	20

50-77-070



CAR END MOUNTING BRACKETS

- Heavy duty plated steel brackets, featuring reinforcing beads or flanges for strength
- The black plated model can blend in with the black connector and black hitch for a clean consistent finish
- Combination brackets have a black, powder coat finish and are formed from 16 gauge steel for strength and durability
- Combination brackets are for use with Bargman® branded 4-Way and 5-Way flat connectors

50-77-071



7-WAY MOUNTING BRACKETS

- These brackets only fit the following car end connectors:
 - Bargman® 7-Way super sealed car ends with cable
 - Bargman® 7-Way thermoplastic or metal car end connectors
 - Bargman® 90° 7-Way pre-Wired cables

Part Number	Description	Packaging	Master Carton
50-77-070	7-Way Mounting Bracket for Car End, Silver	Boxed	100
50-77-071	7-Way Mounting Bracket for Car End, Black	Boxed	100
54-77-071	7-Way Mounting Bracket for Car End, Black	Poly Bag	25

50-77-071



7-WAY UNIVERSAL MOUNTING BRACKET

- Universal mounting bracket with long clamp
- Includes screws and nuts

Part Number	Description	Packaging	Master Carton
54-20012	7-Way US Car Mounting Bracket with Universal Mounting Bracket and Long Clamp, Includes Screws and Nuts, Black	Poly Bag	25

118132



4-WAY AND 6-WAY MOUNTING BRACKET

- Universal for 4-Way and 6-Way connectors
- Holes pre-drilled for assorted connectors and easy installation
- Features hitch ball attachment hole

Part Number	Description	Packaging	Master Carton
118132	Mounting Bracket for 4-Way and 6-Way Round Connectors, Does Not Include Fasteners	Clamshell	3

118149



4-FLAT UNIVERSAL MOUNTING BRACKET

Part Number	Description	Packaging	Master Carton
118149	4-Flat Universal Mounting Bracket	Clamshell	3
118149-010	4-Flat Universal Mounting Bracket, (10 Pack)	Boxed	1

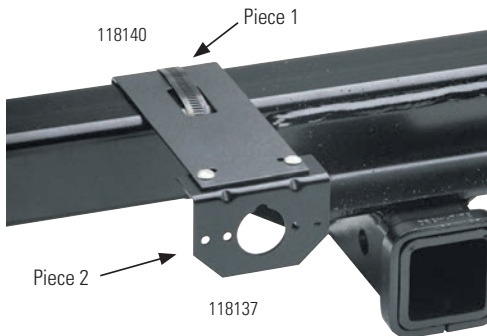

2-PIECE MOUNTING BRACKETS

- The Bargman® line of mounting brackets allows for installation of electrical wiring plugs on vehicles without damage to bumpers or fascia trim
- Attachment brackets are designed to attach above or below receiver cross tube with hose clamp

ATTACHMENT BRACKETS - PIECE 1

- Attaches to cross tube of hitch

Part Number	Description	Packaging	Master Carton
118136	Attachment Bracket for 6-Way and 7-Way Round Connectors, Includes Clamp, Long Bracket	Clamshell	12
118140	Attachment Bracket for 4-Flat, 5-Flat, 4-Way and 5-Way Round Connectors, Includes Clamp, Short Bracket	Clamshell	12



118136



118140



118137

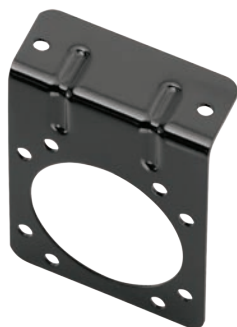

118138



50-98-003

MOUNTING BRACKETS - PIECE 2

- Mounts electrical connector to attachment bracket
- Includes screws and nuts

Part Number	Description	Packaging	Master Carton
118137	Mounting Bracket for 4-Way, 5-Way and 6-Way Connectors, Includes Screws and Nuts	Clamshell	12
118137-010	Mounting Bracket for 4-Way, 5-Way and 6-Way Connectors, Includes Screws and Nuts, (10 Pack)	Poly Bag	1
118138	Mounting Bracket for 7-Way Flat Pin Connectors, Includes Screws and Nuts	Clamshell	12
118138-010	Mounting Bracket for 7-Way Flat Pin Connectors, Includes Screws and Nuts, (10 Pack)	Poly Bag	1
118144	Mounting Bracket for 4-Flat Connectors, Includes Screws and Nuts	Clamshell	12
118144-010	Mounting Bracket for 4-Flat Connectors, Includes Screws and Nuts, (10 Pack)	Poly Bag	1
20212	Mounting Bracket for 7-Way OEM Connectors, Includes Screws and Nuts	Clamshell	12
20212-010	Mounting Bracket for 7-Way OEM Connectors, Includes Screws and Nuts, (10 Pack)	Poly Bag	1
20046	Mounting Bracket for 5-Flat Connectors, Includes Screws and Nuts	Clamshell	12

NOTE: 118138, 118138-010 brackets only fit the following car end connectors:

- Bargman 7-Way Super Sealed Car Ends with Cable
- Bargman 7-Way Thermoplastic or Metal Car End Connectors
- Bargman 90° 7-Way Pre-Wired Cables

6-WAY AND 7-WAY PLUG HOLDER

- Designed to house your 6-Pin or 7-Way trailer end connector safely out-of-the-Way when disconnected from the tow vehicle
- Accommodates either die cast, steel, plastic or molded trailer ends
- Black molded plastic holder mounts on the jack post with provided cable-ties or the attached adhesive strip and can be mounted on any flat surface with provided screws

Part Number	Description	Packaging	Master Carton
50-98-003	6-Pin and 7-Way Plug Holder	Boxed	150

118156



118159



6-PIN AND 7-WAY CONNECTOR MOUNTING BOXES

- No need to disconnect existing wiring
- No drilling
- Mounts with hose clamp included
- Corrosion free
- High impact plastic
- Fits all standard and U.S. car 7-Way connectors

Part Number	Description	Packaging	Master Carton
118156	6-Pin and 7-Way Connector Mounting Box for 2-1/2" Cross tubes	Boxed	1
118156-010	6-Pin and 7-Way Connector Mounting Box for 2-1/2" Cross tubes, (10 Pack)	Boxed	1
118157	6-Pin and 7-Way Connector Mounting Box for 3" Cross tubes	Boxed	1
118157-010	6-Pin and 7-Way Connector Mounting Box, 3" Cross tubes, (10 Pack)	Boxed	1
118159	6-Pin and 7-Way Connector Mounting Box, Universal for Round and Square Cross tubes	Boxed	1
118159-010	6-Pin and 7-Way Connector Mounting Box, Universal for Round and Square Cross tubes, (10 Pack)	Boxed	1

74641



4-FLAT CONNECTOR STORAGE BOX

- Neatly stores 4-Flat and 5-Flat connectors
- Easily installs with included cable ties or screws
- Weatherproof construction

Part Number	Description	Packaging	Master Carton
74641	Electrical Connector Storage Box	Clamshell	3

14-715810



7-WAY JUNCTION BOXES

- Provides a fast, simplified way of connecting wires from the trailer connector to the trailer wiring
- Complete with 5-Wire enter/exit ports, includes hardware, rubber grommets, and features external mounting flanges
- Dimensions: 3-1/4 in. x 6-1/2 in. x 2-1/4 in.

Part Number	Description	Packaging	Master Carton
14-715810	7-Way Junction Box	Poly Bag	18
787535	7-Way Junction Box	Poly Bag	5

NOTE: Most Bargman 7-Way cable products meet UL standards and are appropriately marked. If a non-UL listed cable will be used to connect tow vehicles to trailers capable of housing or transporting live occupants, Horizon Global recommends the use of a wiring Junction Box. This will provide a simplified method of connecting wire leads from the trailer connector to the UL listed trailer wiring.

11755



DIELECTRIC GREASE

- Using dielectric grease on electrical connectors helps prevent corrosion and increases reliability

Part Number	Description	Packaging	Master Carton
11755	Dielectric Grease, 2 oz. Tube	Tube	12

3194-S

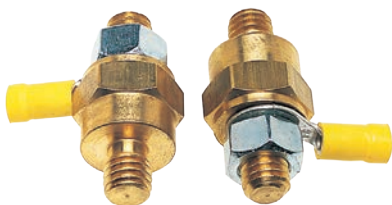

BATTERY POST ADAPTER

- Battery post adapter for General Motors side post batteries
- Allows stud for attaching accessories wires

Part Number	Description	Packaging	Master Carton
3194-S	Battery Post Adapter, 2 Per Package	Clamshell	10

7000



BATTERY ISOLATORS

- Cadmium plated isolator with terminal nuts and lock-washers
- 3 terminal isolator for metal frame ground systems, 4 terminal has insulated ground terminal for use with fiberglass or other non-conductive materials
- Isolates starting battery, provides secondary battery current for auxiliary power and full time charging of both batteries

7001



Part Number	Description	Packaging	Master Carton
7000	Battery Isolator, 3 Terminal	Boxed	10
7000-S	Battery Isolator, 3 Terminal	Litho Box	20
7001	Battery Isolator, 4 Terminal	Boxed	50
7001-S	Battery Isolator, 4 Terminal	Litho Box	20
54-98-004	Battery Isolator, 4 Terminal	Poly Bag	25
118665	Battery Isolation Solenoid, 3 Pole, 12 Volt, Chassis Ground	-	50

118665



TERMINAL RELAYS

- 12 volt
- Vehicle specific

38665-012



38666-010



38667-010



Part Number	Description	Packaging	Master Carton
38665-012	4 Terminal Relay, 12 Volt, 2007-Up Chevrolet Equinox, Pontiac Torrent and Suzuki XL-7/2008-Up Ford Escape, Mazda Tribute and Mercury Mariner, (12 Pack)	Poly Bag	12
38666-010	4 Terminal Relay, Small, 12 Volt, 2004-Up Infiniti QX56, Nissan Armada & Titan/2005-Up Nissan Frontier, Pathfinder and Xterra/2009-Up Suzuki Equator, (10 Pack)	Poly Bag	12
38667-010	6 Terminal Relay, Large, 12 Volt, 2004-Up Infiniti QX56, Nissan Armada & Titan/2005-Up Nissan Frontier, Pathfinder and Xterra/2009-Up Suzuki Equator, (10 Pack)	Poly Bag	12

CIRCUIT BREAKERS

- Used in 6V, 12V and 24V DC applications
- Automotive, RV, air conditioners, battery chargers, any application requiring over-current protection
- Non-corrosive molded cover eliminates grounding when operating against a fault line
- Includes mounting bracket and installed nuts and washers

7011A



7013A



Part Number	Description	Packaging	Master Carton
7010A	15 Amp Circuit Breaker	Boxed	50
7010A-S	15 Amp Circuit Breaker	Clamshell	10
7011A	20 Amp Circuit Breaker	Boxed	50
7011A-S	20 Amp Circuit Breaker	Clamshell	10
7012A	30 Amp Circuit Breaker	Boxed	50
7012A-S	30 Amp Circuit Breaker	Clamshell	10
7013A	40 Amp Circuit Breaker	Boxed	50
7013A-S	40 Amp Circuit Breaker	Clamshell	10
7022A	50 Amp Circuit Breaker	Boxed	50
7022A-S	50 Amp Circuit Breaker	Clamshell	10

HARDWARE COMPONENTS

- Assortment of hardware components designed specifically for the trailer industry

002806



20035-025



Part Number	Description	Packaging	Master Carton
104429	Clip, Plastic Wire, Adhesive Back	Boxed	1,000
002802	Clip, Metal Wire	Poly Bag	1,000
002805	Nut, Wire, Large, 14-16 Gauge	Poly Bag	1,000
002806	Tap, White Wire, Double Leads	Poly Bag	500
002807	Tap, Blue Wire, Single Leads	Poly Bag	500
20034-025	*Perm-A-Seal Butt Connectors, 14-16 Gauge, Blue, (25 Pack)	Poly Bag	12
20035-025	*Perm-A-Seal Butt Connectors, 10-12 Gauge, Yellow, (25 Pack)	Poly Bag	12

*Perm-A-Seal® brand or comparable substitute



6562

7-WAY BLADE TESTERS

Used for the proper installation and set-up of a brake control when a trailer is not readily available. Brake control set-up is accomplished using a built-in load module that will simulate electric magnet brakes on a trailer.

- Will check electrical continuity of all circuits in the 7-Way blade style connector
- Electric brake and battery charge included
- One piece units with internal ground

Part Number	Description	Packaging	Master Carton
6562	7-Way Blade Tester and Trailer Emulator with LED Display	Clamshell	20



6565

CURRENT MONITOR

Designed to assist in determining whether a tow vehicle's 7-Way blade car end connector has been wired properly.

- Excellent diagnostic tool for installation, setup and troubleshooting of electric trailer brake controls
- Used to level and pre-set brake control when trailer is not available

Part Number	Description	Packaging	Master Carton
6565	Current Monitor	Boxed	1



8010

TRAILER TESTER

- Indicates approximate amount of current in each circuit
- Tests voltage of the external battery connected to the trailer charge circuit of electric trailer brake control

Part Number	Description	Packaging	Master Carton
8010	Trailer Tester, Includes Charger	Boxed	1



7585

BRAKE CONTROL BENCH TESTER

- Checks brake control output, independent of vehicle wiring
- Simulates many fault conditions including open ground, short circuit, open load and more

Part Number	Description	Packaging	Master Carton
7585	Brake Control Bench Tester	Boxed	1



20145

CIRCUIT TESTERS

Part Number	Description	Packaging	Master Carton
40376	Circuit Tester	Clamshell	12
3808	Economy Circuit Tester	Clamshell	12
74633	4-Flat Circuit Tester	Clamshell	12
20115	5-Flat Circuit Tester	Clamshell	12
20116	6-Pin Circuit Tester	Clamshell	12
20117	7-Way Circuit Tester	Clamshell	12
20145	LED Circuit Tester	Clamshell	12
20145-010	LED Circuit Tester, (10 Pack)	Boxed	1



118704-050†



22550†



51-87-004†



20321†

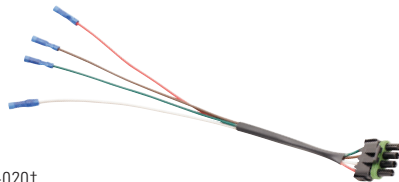

54003-020†



54-6562†



7200†

† = Available while supplies last

VEHICLE / TRAILER ADAPTERS LAST CHANCE

Part Number	Description	Substitute Part Number	Packaging	Master Carton
118702†	7-Way Flat Pin To 4-Flat Adapter	74607	Clamshell	3
118704†	7-Way To 6-Pin Adapter, Electric Brakes To Outer Pin (S)	85216	Clamshell	3
118708†	7-Way To 6-Pin Adapter, Electric Brakes To Center Pin (A)	74645	Clamshell	3
118020†	7-Way Plastic Car End Socket Connector	74126	Clamshell	3

7-WAY VEHICLE COMPLETE KIT LAST CHANCE

Part Number	Description	Substitute Part Number	Packaging	Master Carton
22550†	Universal, Works with Multiplex Vehicles	22551	Boxed	3

7-WAY SUPER SEALED CAR ENDS WITH CABLE LAST CHANCE

Part Number	Description	Substitute Part Number	Packaging	Master Carton
51-87-004†	7-Way Super Sealed Car End with 4' Cable	50-87-004	Bulk	10

7-WAY ELECTRICAL ADAPTER LAST CHANCE

Part Number	Description	Substitute Part Number	Packaging	Master Carton
20321†	4-Flat To 7-Way Connector, Plastic	74184	Clamshell	3

AG REPAIR HARNESS LAST CHANCE

Part Number	Description	Substitute Part Number	Packaging	Master Carton
54003-020†	AG Repair Harness, 4 Wire with 4-Way Weatherpack Connector	-	-	-

7-WAY BLADE TESTER LAST CHANCE

Part Number	Description	Substitute Part Number	Packaging	Master Carton
54-6562†	7-Way Blade Tester and Trailer Emulator with LED Display	6562	Clamshell	20
767943†	7-Way Blade Tester and Trailer Emulator with LED Display	6562	Clamshell	20

ELECTROTEK® DIELECTRIC SILICONE COMPOUND LAST CHANCE

Part Number	Description	Substitute Part Number	Packaging	Master Carton
7200†	Electrotek, 3 oz. Tube	11755	Clamshell	12
7200P†	Electrotek, 3 oz. Tube	11755	Clamshell	12



BRAKE CONTROLS

Your one-stop source for electric brake controllers. Tekonsha® manufactures several electric brake controllers, one or more of which are designed to meet your unique requirements for operational control, weight class, hauling vehicle capabilities, or other factors.

Many styles of electric brake controllers are available that differ in how they look, and the number of brakes they can power, but all of them can be assigned to one of two main groups, Proportional brake controllers, or time delayed brake controllers. Their ease of operation and innovative design features make them the perfect choices for your towing needs.

Smooth, predictable stopping at all speeds has made the Tekonsha® brake controls the best in class and most popular on the market. No matter what you are towing, Tekonsha® will help you stop it.

PROPORTIONAL BRAKE CONTROLS

Prodigy® RF.....	D-2
P3®	D-3
Prodigy® P2.....	D-3
Primus® IQ.....	D-3
Voyager®	D-4
I-Stop™ IQ	D-4
I-Command™	D-4

TIMED BRAKE CONTROLS

Activator® IV.....	D-5
Activator®	D-5
Brakeman® IV.....	D-5
Brakeman® Compact.....	D-4
POD™	D-6
Pilot®	D-6

BRAKE CONTROL ACCESSORIES

Brake Mate™ Kits.....	D-6
Clip and Pivot Mounts	D-7
Bracket Mounts	D-7
Pulse Preventer.....	D-7
Replacement Wiring Harnesses	D-7

BRAKE CONTROL WIRING HARNESSES

Wiring Harnesses.....	D-9
Application Guide	D-10 - D-12

FEATURED



**NOW WITH
BLUETOOTH WIRELESS
COMMUNICATION!**



902501



90253

PRODIGY® RF

The perfect shared-trailer solution. If you take to the road with multiple vehicles, there's really only one solution: Prodigy® RF

Benefits of the Prodigy® RF:

- User does not need a dash mounted, hard wired brake control
- True proportional trailer braking, forward or reverse
- Trailer braking power supplied via 7-Way connector from the vehicle
- Suitable for use on any trailer with up to 3 braking axles

In the Tow Vehicle (Hand Held Unit):

- Wireless communication between the remote hand held unit and trailer mounted power module eliminates the need for under dash wiring
- Easy to see LED display for trailer brake voltage, power output and diagnostics
- Easy to use remote hand held control; includes the Prodigy® "Boost" system to allow for different levels of customized braking
- Unit provides continual diagnostic scanning with a visual warning display
- Hand held unit plugs into any standard 12 volt power accessory adapter
- Hand held unit has a limited 5 year warranty

On the Trailer (Power Module Unit):

- Power module uses standard RV blade style 7-Way truck and trailer connectors
- Trailer power module is watertight and is powered through 7-Way cable from the tow vehicle
- Multiple mounting options on the tongue or front of the trailer
- Trailer mounted power module has a limited 15 year warranty (limited 1 year warranty on cord)
- For 1 to 3 axle trailers



Part Number	Description	Packaging	Master Carton
902501	Prodigy RF Trailer Mount Brake Control with Hand Held Unit with Bluetooth Wireless Communication	Litho Box	2
90250†	Prodigy RF Trailer Mount Brake Control with Hand Held Unit	Litho Box	2
Replacement Part			
90253	Prodigy RF Remote Hand Held Unit with Bluetooth Wireless Communication	Clamshell	3
90251†	Prodigy RF Remote Hand Held Unit	Clamshell	3

NOTE: Part numbers 902501 and 90253 are replacing 90250 and 90251

† = Available while supplies last

PROPORTIONAL CONTROLS offer a smooth braking response to almost any stop. A sensing device determines the tow vehicle's rate of deceleration and then applies the trailer brakes to match.



DECREASED STOPPING DISTANCE - Trailer and vehicle brake at the same rate



90195

P3®

Taking innovation to a whole new level

- 5 storable setting options for pulling different trailers or preferences of multiple drivers
- A distinct, easy-to-read LCD display with multiple screen color options
- “Up-Front” controls provide easy access to all P3® features
- Easy to understand diagnostics show output current, battery/brake/output voltage
- A “flashing red” warning system alerts “No Trailer Brake” situations
- Select Electric over Hydraulic or Electric trailer brake mode
- Numerous mounting options - including 360 degree vertical rotation
- Screen information display in English, French or Spanish
- “The Original Boost” feature allows for customized braking
- Integrated Plug & Play port for 2-Plug adapters
- Snap-in mounting clip allows user to remove and store the control when not in use
- Mounting clip, hardware and 2 ft. pigtail harness kit included
- For 1 to 4 axle trailers



Part Number	Description	Packaging	Master Carton
90195	P3 Proportional Electronic Trailer Brake Control	Litho Box	20

PRODIGY® P2



90885



PRODIGY® P2

Advanced Intelligence

- Auto dim feature allows for better viewing, day or night
- Reverse battery protection for both vehicle and breakaway
- Designed to work with electric over hydraulic brake systems
- Numerous mounting options – including 360 degree vertical rotation
- Digital display depicts voltage delivery to trailer during braking
- No level adjustment necessary – it adjusts itself to varying terrain
- Works proportionally in reverse - with the ability to disable
- Produces stops that are in proportion to vehicle’s deceleration rate
- “The Original Boost” feature allows for customized braking
- Integrated Plug & Play port for 2-Plug adapters
- Pocket-mount allows user to remove and store the control when not in use
- Mounting bracket, hardware and 2 ft. pigtail harness kit included
- For 1 to 4 axle trailers



Part Number	Description	Packaging	Master Carton
90885	Prodigy P2 Proportional Electronic Trailer Brake Control	Litho Box	20

PRIMUS® IQ



90160

PRIMUS® IQ

The smarter braking solution

- Works proportionally in reverse
- No level adjustment necessary, adjusts to varying terrain
- Digital display shows voltage to trailer during braking
- “The Original Boost” feature allows for customized braking
- Integrated Plug & Play port for 2-Plug adapters
- Diagnostic features incorporated in LED display
- Snap-in mounting clip allows user to remove and store the control when not in use
- Mounting bracket, hardware and 1 ft. pigtail harness kit included
- For 1 to 3 axle trailers



Part Number	Description	Packaging	Master Carton
90160	Primus IQ Proportional Electronic Trailer Brake Control	Litho Box	20

VOYAGER®

9030



VOYAGER®

The Voyager® incorporates Tekonsha's patented braking sensor and is the best value you'll find for smooth and secure trailer braking.

- Broad control range makes setting quick and easy
- As braking power is applied, the LED changes color gradually from green (completed circuit) to red, to indicate relative braking power
- Advanced electronics minimize false braking for smoother ride
- Plug & Play feature allows quick and easy connection
- Mounting bracket and hardware included
- For 1 to 4 axle trailers



Part Number	Description	Packaging	Master Carton
9030	Voyager Proportional Electronic Trailer Brake Control	Litho Box	20

i-Stop™ IQ

20191†



I-STOP™ IQ

A totally proportional electric trailer brake control, I-Stop® IQ is self-leveling so no level adjustment is necessary.

- Integrated Plug & Play port for 2-Plug adapters
- Self-diagnostics features will illuminate LED readout when issues occur
- Includes a "Boost" feature
- Works proportionally in reverse
- Snap-in dash mounting clip and hardware included
- Digital LED readout
- Snap-in mounting clip allows user to remove and store the control when not in use
- Mounting bracket, hardware and 1 ft. pigtail harness kit included
- For 1 to 3 axle trailers



Part Number	Description	Packaging	Master Carton
20191†	I-Stop IQ Proportional Electronic Trailer Brake Control	Litho Box	20

† = Available while supplies last

5535



I-COMMAND™

Exclusive to Draw-Tite®

- Proportional brake control
- Boost feature gives the ability to apply more initial trailer braking
- Reverse battery protection
- No level adjustment necessary
- Diagnostics features incorporated in LED display
- Plug & Play feature allows for quick and easy connection
- Mounting bracket and hardware included
- For 1 to 4 axle trailers



Part Number	Description	Packaging	Master Carton
5535	I-Command Proportional Electronic Trailer Brake Control	Clamshell	12

NOTE: Plug & Play feature allows quick and easy connection. It adapts to all Tekonsha 2-Plug vehicle specific brake control wiring harnesses.

See application guide for vehicle specific applications.

ACTIVATOR IV



5504

ACTIVATOR® IV

- Digital output indicator
- Small, compact design
- Up-front push buttons for sync and output
- Diagnostics for overload, open ground
- Short circuit protected
- Mounts in any direction
- No leveling required
- Smooth and simple installation
- Plug & Play feature allows quick and easy connection
- Mounting bracket and hardware included
- For 1 to 4 axle trailers



Part Number	Description	Packaging	Master Carton
5504	Activator IV Timed Electronic Trailer Brake Control	Clamshell	12

ACTIVATOR®



5100

ACTIVATOR®

- Illuminated LED output indicator
- Slide adjustment output control
- Plug & Play feature allows quick and easy connection
- Mounting bracket and hardware included
- For 1 to 2 axle trailers



Part Number	Description	Packaging	Master Carton
5100	Activator Timed Electronic Trailer Brake Control	Clamshell	12

BRAKEMAN® IV



83504

- Digital output indicator
- Small, compact design
- Up-front push buttons for sync and output
- Diagnostics for overload, open ground
- Short circuit protected
- Mounts in any direction
- No leveling required
- Smooth and simple installation
- Plug & Play feature allows quick and easy connection
- Mounting bracket and hardware included
- For 1 to 4 axle trailers



Part Number	Description	Packaging	Master Carton
83504	Brakeman IV Timed Electronic Trailer Brake Control	Clamshell	12

BRAKEMAN® COMPACT



83501

- Illuminated LED output indicator
- Slide adjustment output control
- "Up-front" manual over-ride control
- Smooth and simple installation
- Plug & Play feature allows quick and easy connection
- Mounting bracket and hardware included
- For 1 to 2 axle trailers



Part Number	Description	Packaging	Master Carton
83501	Brakeman Compact Timed Electronic Trailer Brake Control	Clamshell	12



80500

POD™

The POD™ (Power on Demand) is your best choice for 1 or 2 axle trailers, especially when your installation options are limited.

- Power-on LED for a positive tow vehicle-to-trailer connection
- “Up-front” manual over-ride control
- Rugged, easy mount chassis
- Smooth and simple installation
- Solid state electronics
- Plug & Play feature allows quick and easy connection
- Mounting bracket and hardware included
- For 1 to 2 axle trailers



Part Number	Description	Packaging	Master Carton
80500	POD Timed Electronic Trailer Brake Control	Clamshell	20

PILOT®



80550

PILOT®

The Pilot® has just made owning and operating a digital brake control easier than ever.

- Large easy to read dual digital display
- Dark smoke lens ideal for direct light applications; performs better than red lens
- Microprocessor allows control to be mounted upside down and still have a readable display
- Protection against short circuit and loss of ground
- For use on any 12 volt negative ground system
- Plug & Play feature allows quick and easy connection
- Mounting bracket and hardware included
- For 1 to 3 axle trailers



Part Number	Description	Packaging	Master Carton
80550	Pilot Timed Electronic Trailer Brake Control	Clamshell	20



118607

BRAKE MATE™ KITS

Includes all necessary parts required to completely install all brake controls. Each Brake Mate™ Kit includes:

- (1) Pre-wired 7-Way round connector
- (1) Heavy duty flasher
- (2) Heavy duty breakers
- (8) Self tapping screws
- (1) Integrated 4-Flat trailer end
- (6) Tie straps
- (5) Scotch locks
- (7) Ring connectors



20505

Part Number	Description	Packaging	Master Carton
118607	7-Way Brake Mate Kit, Flat Pin	Clamshell	12
20505	Wiring Kit for 1 - 2 Axles Brake Control Systems, Includes 25' 12-2 Duplex Wire, 20 Amp Circuit Breaker and Attaching Terminals	Clamshell	12
20506	Wiring Kit for 3 - 4 Axles Brake Control Systems, Includes 25' 10-2 Duplex Wire, 30 Amp Circuit Breaker and Attaching Terminals	Clamshell	12

CLIP AND PIVOT MOUNTING



5904



6927

Part Number	Description	Application	Packaging	Master Carton
5901TEK	Dash Mounting Clip	P3, 90195	Bulk	1
5904	Dash Mounting Clip Bracket	P3, 90195	Bulk	1
5906	T-Slot Mounting Kit	P3, 90195	Poly Bag	10
5298	Dash Pivot Mounting Kit	Pilot, 80550	Clamshell	1
7686	Dash Pocket Mounting Kit	Prodigy P2, 90885	Boxed	1
6927	Dash Mounting Clip	Primus IQ, 90160 and I-Stop IQ, 20191	Bulk	1

TRADITIONAL BRACKET MOUNTING



7685



2178

Part Number	Description	Application	Packaging	Master Carton
7685	Mounting Bracket Kit	Prodigy P2, 90885	Clamshell	10
5280	Mounting Bracket Only	Primus IQ, 90160, I-Stop IQ, 20191 and Pilot, 80550	Bulk	1
2178	Mounting Bracket Kit	P3, 90195, Voyager, 9030 and POD, 80500	Poly Bag	10
20059	Mounting Bracket Kit	Activator IV, 5504, Brakeman IV, 83504 and I-Command, 5535	Poly Bag	20
20060	Mounting Bracket Kit	Activator, 5100 and Brakeman, 83501	Poly Bag	20

PULSE PREVENTER

- Immunizes against the effects of 4-way flashers on some brake controls

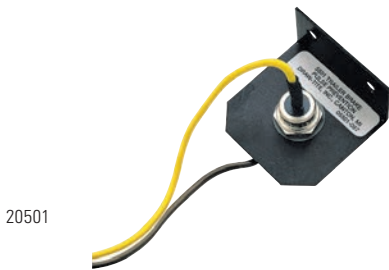

20501

Part Number	Description	Packaging	Master Carton
20501	Pulse Preventer	Clamshell	20

REPLACEMENT WIRING HARNESSES

- Fits all Tekonsha®, Draw-Tite® and REESE® brake controls



7894

Part Number	Description	Packaging	Master Carton
7865	30" Pigtail Harness with Diode	Clamshell	20
7894	30" Pigtail Harness	Clamshell	20
20127	12" Pigtail Harness	Clamshell	20
20127-012	12" Pigtail Harness, (12 Pack)	Bulk	1
20160	60" Pigtail Harness	Clamshell	12
20160-012	60" Pigtail Harness, (12 Pack)	Bulk	1

BRAKE CONTROL WIRING HARNESSES

- All vehicle specific brake control wiring harnesses are available in 1-Plug or 2-Plug styles
- 1-Plug units are designed for brake controls manufactured with electrical wiring mounted on the back of the unit, otherwise known as a pigtail. Wiring harnesses must be spliced into the existing pigtail to allow the vehicle specific plug to be installed.
- 2-Plug units are designed for brake controls that have a wiring port built into the back of the unit. Simply plug the brake control end of the wiring harness into the back of the brake control and the vehicle end into the automobile's port. Brake controls that utilize the 2-Plug style of wiring harness will be identified with the Plug & Play logo.
- See application guide for vehicle specific harnesses

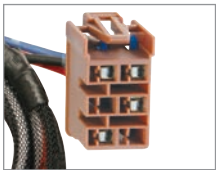

3015 / 3015-P / 3015-S

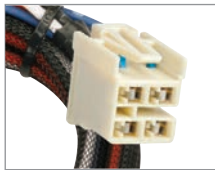

3016 / 3016-P / 3016-S

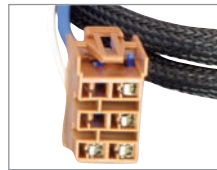

3025 / 3025-P / 3025-S



3035 / 3035-P / 3035-S



3036 / 3036-P / 3036-S



3070 / 3070-P / 3070-S



3045 / 3045-P / 3045-S



3021 / 3021-P / 3021-S



3023 / 3023-P / 3023-S
30234-P / 30235 / 30235-P



3050 / 3050-P / 3050-S



3014 / 3014-P / 3014-S



3020 / 3020-P



3024 / 3024-P



3026 / 3026-P / 3026-S



3027 / 3027-P



3031 / 3031-P / 3031-S



3032 / 3032-P



3034 / 3034-P / 3034-S



3040 / 3040-P / 3040-S

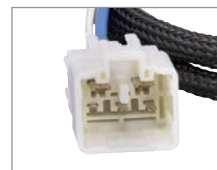

3041 / 3041-P



3065 / 3065-P / 3065-S



3063 / 3063-P



3030 / 3030-P



3064 / 3064-P



3065 / 3065-P / 3065-S



3028 / 3028-P

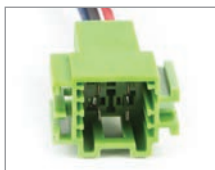

3066 / 3066-P



3062 / 3062-P

BRAKE CONTROL WIRING HARNESS APPLICATION GUIDE

Make/Model	Years	Pos.	1-Plug	2-Plug Clam	2-Plug Bulk
ACURA					
MDX	13-19	BP1		3028-P	3028
BUICK					
Enclave with Factory 7-Way	08-17	BP1	3026-S	3026-P	3026
CADILLAC					
Escalade	02	BP1	3025-S	3025-P	3025
Escalade	03-06	BP1	3015-S	3015-P	3015
Escalade	15-19	BP2	3016-S	3016-P	3016
Escalade ESV	03-06	BP1	3015-S	3015-P	3015
Escalade EXT	02	BP1	3025-S	3025-P	3025
Escalade EXT	03-06	BP1	3015-S	3015-P	3015
CHEVROLET					
Avalanche 1500	02	BP1	3025-S	3025-P	3025
Avalanche 1500	03-06	BP1	3015-S	3015-P	3015
Avalanche 2500	02	BP1	3025-S	3025-P	3025
Avalanche 2500	03-06	BP1	3015-S	3015-P	3015
Silverado 1500	99-02	BP1	3025-S	3025-P	3025
Silverado 1500	03-06	BP1	3015-S	3015-P	3015
Silverado 1500	14-18	BP2	3016-S	3016-P	3016
Silverado 1500 (Classic)	07	BP1	3015-S	3015-P	3015
Silverado 1500 (New Body Style)	19	BP1		3064-P	3064
Silverado 1500 HD	01-02	BP1	3025-S	3025-P	3025
Silverado 1500 HD	03-06	BP1	3015-S	3015-P	3015
Silverado 1500 HD (Classic)	07	BP1	3015-S	3015-P	3015
Silverado 2500	99-02	BP1	3025-S	3025-P	3025
Silverado 2500	03-04	BP1	3015-S	3015-P	3015
Silverado 2500 HD	01-02	BP1	3025-S	3025-P	3025
Silverado 2500 HD	03-06	BP1	3015-S	3015-P	3015
Silverado 2500 HD	15-19	BP2	3016-S	3016-P	3016
Silverado 2500 HD (Classic)	07	BP1	3015-S	3015-P	3015
Silverado 3500	01-02	BP1	3025-S	3025-P	3025
Silverado 3500	03-06	BP1	3015-S	3015-P	3015
Silverado 3500 (Classic)	07	BP1	3015-S	3015-P	3015
Silverado 3500 HD	15-19	BP2	3016-S	3016-P	3016
Suburban	15-17	BP2	3016-S	3016-P	3016
Suburban 1500	03-06	BP1	3015-S	3015-P	3015
Suburban 1500 with Amber Turn Signals	00-02	BP1	3025-S	3025-P	3025
Suburban 2500	03-06	BP1	3015-S	3015-P	3015
Suburban 2500 with Amber Turn Signals	00-02	BP1	3025-S	3025-P	3025
Tahoe	03-06	BP1	3015-S	3015-P	3015
Tahoe	15-16	BP2	3016-S	3016-P	3016
Tahoe with Amber Turn Signals	00-02	BP1	3025-S	3025-P	3025
Traverse with Factory 7-Way	09-17	BP1	3026-S	3026-P	3026
CHRYSLER					
Aspen with Factory Tow Package	07-09	BP2	3020-S	3020-P	3020
Pacifica with Factory 7-Way	17-19	BP4	3045-S	3045-P	3045
DODGE					
Dakota with Factory Tow Package	97-10	BP2	3020-S	3020-P	3020
Durango with Factory Tow Package	98-09	BP2	3020-S	3020-P	3020
Durango with Factory Tow Package	11-19	BP2	3045-S	3045-P	3045

Make/Model	Years	Pos.	1-Plug	2-Plug Clam	2-Plug Bulk
DODGE (continued)					
Ram 1500	95-09	BP2	3020-S	3020-P	3020
Ram 1500	10	BP1	3021-S	3021-P	3021
Ram 2500	95-09	BP2	3020-S	3020-P	3020
Ram 2500	10	BP1	3021-S	3021-P	3021
Ram 3500	95-09	BP2	3020-S	3020-P	3020
Ram 3500	10	BP1	3021-S	3021-P	3021
Sprinter 2500	07-09	BP10		3063-P	3063
Sprinter 3500	07-09	BP10		3063-P	3063
FORD					
Bronco	94-96	BP3	3035-S	3035-P	3035
E-150 Econoline	92-08	BP3	3035-S	3035-P	3035
E-150 Econoline	09-14	BP7	3034-S	3034-P	3034
E-250 Econoline	92-08	BP3	3035-S	3035-P	3035
E-250 Econoline	09-14	BP7	3034-S	3034-P	3034
E-350 Econoline	92-08	BP3	3035-S	3035-P	3035
E-350 Econoline RV Cutaway, with Factory Tow Prep Plug	92-08	BP3	3035-S	3035-P	3035
E-350 Econoline Super Duty RV Cutaway, with Factory Tow Prep Plug	09-11	BP7	3034-S	3034-P	3034
E-350 Econoline Super Duty	09-14	BP7	3034-S	3034-P	3034
E-450 Econoline Super Duty RV Cutaway, with Factory Tow Prep Plug	03-08	BP3	3035-S	3035-P	3035
E-450 Econoline Super Duty RV Cutaway, with Factory Tow Prep Plug	09-11	BP7	3034-S	3034-P	3034
E-450 Econoline Super Duty Stripped RV Cutaway, with Factory Tow Prep Plug	00-02	BP3	3035-S	3035-P	3035
Excursion	00-05	BP3	3035-S	3035-P	3035
Expedition	97-12	BP3	3035-S	3035-P	3035
Expedition	13-14	BP5	3034-S	3034-P	3034
Expedition	15-17	BP3	3036-S	3036-P	3036
Explorer with Factory Tow Package	02-19	BP2	3035-S	3035-P	3035
Explorer Sport Trac with Factory Tow Package	07-10	BP2	3035-S	3035-P	3035
F-150	94-08	BP3	3035-S	3035-P	3035
F-150	09-19	BP3	3036-S	3036-P	3036
F-150 Heritage	04	BP3	3035-S	3035-P	3035
F-250	94-96	BP3	3035-S	3035-P	3035
F-250 Heavy Duty	97	BP3	3035-S	3035-P	3035
F-250 Styleside	97-99	BP3	3035-S	3035-P	3035
F-250 Super Duty	99-04	BP3	3035-S	3035-P	3035
F-250 Super Duty	05-07	BP5	3065-S	3065-P	3065
F-250 Super Duty	08-16	BP3	3034-S	3034-P	3034
F-250 Super Duty	17-19	BP3	3036-S	3036-P	3036
F-350	94-96	BP3	3035-S	3035-P	3035
F-350 Heavy Duty	97	BP3	3035-S	3035-P	3035
F-350 Super Duty	99-04	BP3	3035-S	3035-P	3035
F-350 Super Duty	05-07	BP5	3065-S	3065-P	3065
F-350 Super Duty	08-16	BP3	3034-S	3034-P	3034
F-350 Super Duty	17-19	BP3	3036-S	3036-P	3036
F-350 Super Duty Cab & Chassis	05-07	BP5	3065-S	3065-P	3065
F-350 Super Duty Cab & Chassis	08-16	BP3	3034-S	3034-P	3034
F-450 Super Duty	08-16	BP3	3034-S	3034-P	3034

BRAKE CONTROL WIRING HARNESS APPLICATION GUIDE

Make/Model	Years	Pos.	1-Plug	2-Plug Clam	2-Plug Bulk
FORD (continued)					
F-450 Super Duty	17-19	BP3	3036-S	3036-P	3036
F-450 Super Duty Cab & Chassis	99-04	BP3	3035-S	3035-P	3035
F-450 Super Duty Cab & Chassis	05-07	BP5	3065-S	3065-P	3065
F-450 Super Duty Cab & Chassis	08-16	BP3	3034-S	3034-P	3034
F-550 Super Duty	17-18	BP3	3036-S	3036-P	3036
F-550 Super Duty Cab & Chassis	99-04	BP3	3035-S	3035-P	3035
F-550 Super Duty Cab & Chassis	05-07	BP5	3065-S	3065-P	3065
F-550 Super Duty Cab & Chassis	08-16	BP3	3034-S	3034-P	3034
Flex with Factory Tow Package	09-11	BP2	3035-S	3035-P	3035
Flex with Factory Tow Package	12-16	BP5	3036-S	3036-P	3036
Windstar with Factory Tow Package	95-03	BP3	3035-S	3035-P	3035
FREIGHTLINER					
SL	04-16			3027-P	3027
Sprinter 2500	07-11	BP10		3063-P	3063
Sprinter 2500	12-18	BP10		3030-P	3030
Sprinter 3500	07-11	BP10		3063-P	3063
Sprinter 3500	12-18	BP10		3030-P	3030
XC	04-16			3027-P	3027
GMC					
Acadia with Factory 7-Way	07-17	BP1	3026-S	3026-P	3026
Acadia Limited with Factory 7-Way	17	BP1	3026-S	3026-P	3026
Sierra 1500	99-02	BP1	3025-S	3025-P	3025
Sierra 1500	03-06	BP1	3015-S	3015-P	3015
Sierra 1500 (Classic)	07	BP1	3015-S	3015-P	3015
Sierra 1500 (New Body Style)	19	BP1		3064-P	3064
Sierra 1500 LD (Old Body Style)	14-19	BP2	3016-S	3016-P	3016
Sierra 1500 HD	01-02	BP1	3025-S	3025-P	3025
Sierra 1500 HD	03-06	BP1	3015-S	3015-P	3015
Sierra 1500 HD (Classic)	07	BP1	3015-S	3015-P	3015
Sierra 2500	99-02	BP1	3025-S	3025-P	3025
Sierra 2500	03-04	BP1	3015-S	3015-P	3015
Sierra 2500 HD	01-02	BP1	3025-S	3025-P	3025
Sierra 2500 HD	03-06	BP1	3015-S	3015-P	3015
Sierra 2500 HD	15-19	BP2	3016-S	3016-P	3016
Sierra 2500 HD (Classic)	07	BP1	3015-S	3015-P	3015
Sierra 3500	01-02	BP1	3025-S	3025-P	3025
Sierra 3500	03-06	BP1	3015-S	3015-P	3015
Sierra 3500 (Classic)	07	BP1	3015-S	3015-P	3015
Sierra 3500 HD	15-19	BP2	3016-S	3016-P	3016
Yukon	03-06	BP1	3015-S	3015-P	3015
Yukon	15-16	BP2	3016-S	3016-P	3016
Yukon with Amber Turn Signals	00-02	BP1	3025-S	3025-P	3025
Yukon Denali	03-06	BP1	3015-S	3015-P	3015
Yukon Denali with Amber Turn Signals	01-02	BP1	3025-S	3025-P	3025
Yukon XL 1500	00-02	BP1	3025-S	3025-P	3025
Yukon XL 1500	03-06	BP1	3015-S	3015-P	3015
Yukon XL 1500 Denali	01-02	BP1	3025-S	3025-P	3025
Yukon XL 1500 Denali	03-06	BP1	3015-S	3015-P	3015
Yukon XL 2500	00-02	BP1	3025-S	3025-P	3025
Yukon XL 2500	03-06	BP1	3015-S	3015-P	3015

Make/Model	Years	Pos.	1-Plug	2-Plug Clam	2-Plug Bulk
HONDA					
Pilot with Factory Tow Package	09-19	BP1	3070-S	3070-P	3070
Ridgeline with Factory Tow Package	06-19	BP1	3070-S	3070-P	3070
Ridgeline with Factory Tow Package	17-19	BP1	3070-S	3070-P	3070
HUMMER					
H2	03-07	BP1	3015-S	3015-P	3015
INFINITI					
QX56	04-13	BP1	3050-S	3050-P	3050
JEEP					
Cherokee	14-19	BP1	3014-S	3014-P	3014
Grand Cherokee with Factory Tow Package	11-19	BP2	3045-S	3045-P	3045
KIA					
Borrego	09-11	BP4		3032-P	3032
LAND ROVER					
LR3	05-09	BP3	3035-S	3035-P	3035
LR4	10-15	BP3	3035-S	3035-P	3035
Range Rover	05-14	BP3	3035-S	3035-P	3035
Range Rover	15	BP3	3035-S	3035-P	3035
Range Rover Evoque	12-17	BP2	3035-S	3035-P	3035
LEXUS					
GX460	10-15	BP4	3040-S	3040-P	3040
GX470	03-09	BP3	3040-S	3040-P	3040
LX470	03-07	BP3	3040-S	3040-P	3040
LX570	08-11	BP3	3040-S	3040-P	3040
LX570	13-15	BP4	3040-S	3040-P	3040
LINCOLN					
Aviator with Factory Tow Package	03-05	BP6	3035-S	3035-P	3035
Mark LT	06-08	BP3	3035-S	3035-P	3035
MKT with Factory Tow Package	10-11	BP1	3035-S	3035-P	3035
MKT with Factory Tow Package	12-15	BP1	3036-S	3036-P	3036
Navigator	98-12	BP3	3035-S	3035-P	3035
Navigator	13-14	BP3	3034-S	3034-P	3034
Navigator	15-17	BP1	3036-S	3036-P	3036
MERCEDES-BENZ					
GL350 with Factory Tow Package	12-15	BP2		3066-P	3066
GL450 with Factory Tow Package	12-15	BP2		3066-P	3066
GL550 with Factory Tow Package	12-15	BP2		3066-P	3066
GLE350 with Factory Tow Package	16-18	BP2		3066-P	3066
GLE43 AMG with Factory Tow Package	17-18	BP2		3066-P	3066
GLE550 with Factory Tow Package	16	BP2		3066-P	3066
GLE63 AMG with Factory Tow Package	16-18	BP2		3066-P	3066
GLS450 with Factory Tow Package	17-18	BP2		3066-P	3066
GLS550 with Factory Tow Package	17-18	BP2		3066-P	3066
GLS63 AMG with Factory Tow Package	17-18	BP2		3066-P	3066
ML250 with Factory Tow Package	15	BP2		3066-P	3066
ML350 with Factory Tow Package	12-15	BP2		3066-P	3066
ML400 with Factory Tow Package	15	BP2		3066-P	3066

Make/Model	Years	Pos.	1-Plug	2-Plug Clam	2-Plug Bulk
MERCEDES-BENZ (continued)					
Sprinter	07-11	BP10		3063-P	3063
Sprinter	12-18	BP10		3030-P	3030
Sprinter 2500	10-11	BP10		3063-P	3063
Sprinter 2500	12-18	BP10		3030-P	3030
Sprinter 3500	10-11	BP10		3063-P	3063
Sprinter 3500	12-18	BP10		3030-P	3030
MERCURY					
Mountaineer with Factory Tow Package	02-10	BP2	3035-S	3035-P	3035
NISSAN					
Armada	05-19	BP1	3050-S	3050-P	3050
Frontier	05-19	BP3	3050-S	3050-P	3050
NV1500	13-18	BP1	3050-S	3050-P	3050
NV2500	13-18	BP1	3050-S	3050-P	3050
NV3500	13-18	BP1	3050-S	3050-P	3050
Pathfinder	05-19	BP3	3050-S	3050-P	3050
Pathfinder Armada	04	BP1	3050-S	3050-P	3050
Titan Except Titan XD	04-19	BP1	3050-S	3050-P	3050
Xterra with Factory Tow Package	05-15	BP3	3050-S	3050-P	3050
RAM					
1500	11-12	BP1	3021-S	3021-P	3021
1500	13-14	BP3 BP8	3023-S	3023-P 30234-P	3023
1500 (Classic)	13-19	BP9		30235-P	30235
1500 (Classic)	15-19	BP2		3024-P	3024
1500 (New Body Style)	19	BP9		30235-P	30235
2500	11-12	BP1	3021-S	3021-P	3021
2500	13-14	BP3 BP8	3023-S	3023-P 30234-P	3023
2500	13-19	BP9		30235-P	30235
2500	15-19	BP2		3024-P	3024
3500	11-12	BP1	3021-S	3021-P	3021
3500	13-14	BP3 BP8	3023-S	3023-P 30234-P	3023
3500	13-19	BP9		30235-P	30235
3500	15-19	BP2		3024-P	3024
Dakota with Factory Tow Package	11	BP2	3020-S	3020-P	3020
SATURN					
Outlook with Factory 7-Way	07-09	BP1	3026-S	3026-P	3026
SUBARU					
Ascent	19	SUV3		3062-P	3062
TOYOTA					
4Runner	03-13	BP4	3040-S	3040-P	3040
4Runner	14-16	BP4		3041-P	3041
Land Cruiser	03-11	BP3	3040-S	3040-P	3040
Land Cruiser	13-15	BP3	3040-S	3040-P	3040
Sequoia	03-19	BP4	3040-S	3040-P	3040
Tacoma	07-15	BP4	3040-S	3040-P	3040
Tacoma	16-19	BP7	3031-S	3031-P	3031
Tacoma	16-17	BP7		3017-P	3017
Tundra	03-14	BP4	3040-S	3040-P	3040
Tundra	15-17	BP7	3031-S	3017-P	3017

NOTES:

- 1-Plug units are designed for brake controls manufactured with electrical wiring mounted on the back of the unit, otherwise known as a pigtail. Wiring harnesses must be spliced into the existing pigtail to allow the vehicle specific plug to be installed.
- 2-Plug units are designed for brake controls that have a wiring port built into the back of the unit. Simply plug the brake control end of the wiring harness into the back of the brake control and the vehicle end into the automobile's port. Brake controls that utilize the 2-plug style of wiring harness will be identified with the Plug & Play logo.

ELECTRICAL POSITIONS:

- BP1 - Under or behind dash, to the left or right of the emergency brake pedal.
- BP2 - Under or behind dash to the left of the steering column and brake pedal.
- BP3 - Under or behind dash to the right of the steering column and brake pedal.
- BP4 - Kick panel area, on the driver's side.
- BP5 - Under or behind dash, behind the center console.
- BP6 - Under or behind dash on the passenger side, near glovebox.
- BP7 - Centered behind dash between the steering column and the radio.
- BP8 - Under or behind dash to the right of the steering column and brake pedal. Also includes 7-Way adapter kit located at the rear center behind the bumper. This unit complies with all applicable California Regulations.
- BP9 - Includes 7-Way adapter kit located at the rear center behind the bumper. This unit complies with all applicable California Regulations.
- BP10 - Under drivers seat





WEIGHT DISTRIBUTION

Founded in 1952, the REESE® brand has become a household name in the heavy-duty towing industry. With proven designs that exceed the industry standards, REESE® has become the brand of choice when performance is the expectation.

Evolving to meet the changing requirements of the towing market, our Weight Distributing Hitch Systems provide a softer ride and distribute load forces more evenly than ever before.

SELECTING A SYSTEM E-3

WEIGHT DISTRIBUTION SYSTEMS

- REESE® Pro Round Bar E-2
- STEADi-Flex® E-4
- Strait-Line® E-5
- High Performance Trunnion Style E-6

SWAY CONTROL

- Dual Cam HP E-6
- Friction Sway Control E-7
- Bolt-On Mounting Adapters E-8

WEIGHT DISTRIBUTION ACCESSORIES

- Hitch Bars E-7
- Pole Tongue Adapters E-7
- Adjustable Ball Mounts with Hitch Bars E-8
- Snap-Up Brackets E-8
- Chain Hangers E-8
- Tongue Weight Scale E-8

REPLACEMENT PARTS.....E-9 - E-13

DISCONTINUED PRODUCTS E-14

NEW

REESE® PRO ROUND BAR SYSTEM

Engineered to provide more features and superior ride performance than other systems. Designed to evenly and effectively distribute weight, while reducing trailer sway.

- Designed to improve stability for added ride control and security
- 2-5/16 in. hitch ball - Pre-installed and torqued to proper specifications
- Includes 8-1/2 in. deep drop shank for today's taller trucks
- No-drill, clamp on brackets fit up to 7 in. trailer frames
- High strength steel head and welded hitch bar
- Tapered spring bars provide constant weight distribution over the axles for superior ride comfort
- Fits bottom and top mount couplers
- Powder coat finish for durability and corrosion resistance
- System includes: Head with preinstalled ball, tapered spring bars, deep drop shank, control brackets, lift-assist bar and all hardware necessary for an easy install



49912

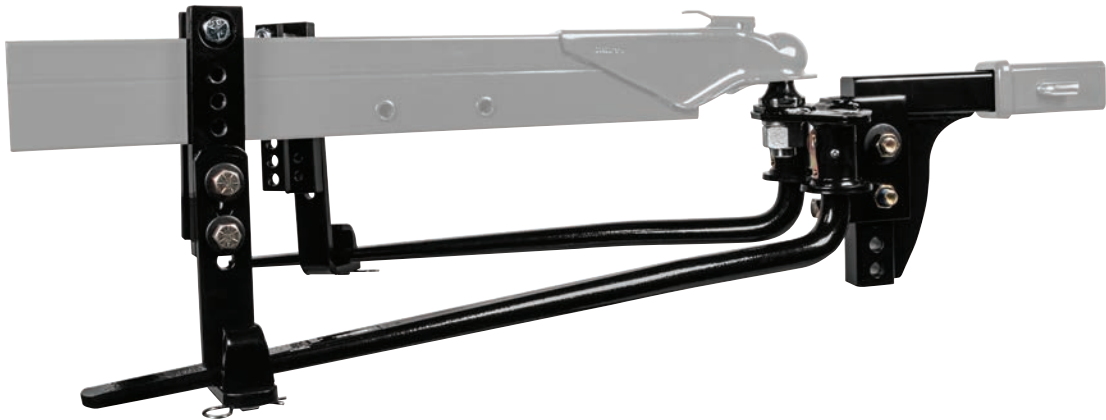

Part Number	Description	Gross Trailer Weight (lbs.)	Tongue Weight (lbs.)	Packaging	Master Carton
49911	REESE Pro Round Bar System with Integrated Sway Control	6,000	600	Boxed	1
49912	REESE Pro Round Bar System with Integrated Sway Control	8,000	800	Boxed	1
49913	REESE Pro Round Bar System with Integrated Sway Control	11,500	1,150	Boxed	1



Includes deep drop shank



No drill clamp on bracket installation



High strength steel head and welded hitch bar



Integrated sway control

WEIGHT DISTRIBUTING SYSTEMS

- Add a weight distributing system to provide a more level ride, greater steering and brake control
- The differences are in construction materials, welding, manufacturing processes and hook-up
- Adjustment is simple because of the easy-to-operate snap-up brackets that allow spring bar tension to be adjusted by changing links in the support chains
- Rather than merely supporting the trailer tongue weight (TW), weight-distributing hitches apply leverage between the towing vehicle and trailer causing the TW to be carried by all axles of the tow vehicle and trailer

**They work in unison to provide complete towing system compatibility.*

- A Weight Distributing Hitch System is composed of **four major elements:*
 1. The hitch receiver
 2. The weight distribution kit
 3. The hitch ball
 4. The sway control (see below)

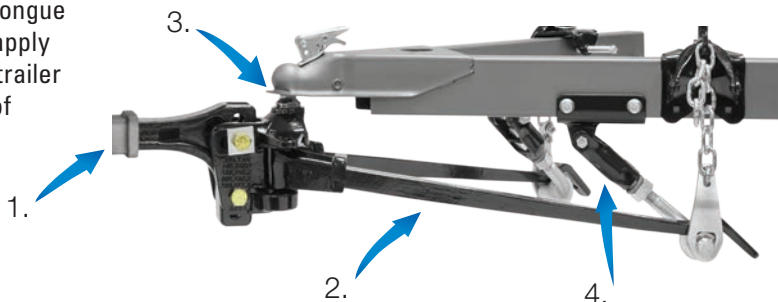

TO DETERMINE THE CORRECT WEIGHT DISTRIBUTING HITCH:

1. Determine the tongue weight of your trailer
2. Estimate the vehicle cargo load
3. Match the sum of these weights to the proper Reese weight distributing hitch

HITCH WEIGHT = TONGUE WEIGHT + VEHICLE CARGO LOAD BEHIND REAR AXLE

- Tongue weight includes the trailer tongue weight with full gas, water and waste systems and everything packed inside the trailer. Vehicle cargo includes all materials carried in your tow vehicle, such as boat motors, gas cans, tools, etc.

		TONGUE WEIGHT IN USE																
RATING		200	300	400	500	600	700	800	900	1000	1100	1200	1300	1400	1500	1600	1700	
600		█																
800			█				█											
1000				█				█										
1200					█				█									
1400							█				█							
1500									█				█					
1700											█				█			

EXAMPLE:

Tongue Weight - 500 lbs.
 Vehicle Load Weight - + 200 lbs.

 Total Hitch Weight - = 700 lbs.

*Using the selector shown above, an 800 lbs. tongue weight distributing hitch is adequate.

600 LBS. WEIGHT DISTRIBUTING HITCH

- Specially suited for use on medium boat trailers, light travel trailers, single horse trailers, heavy fold-down campers, heavy luggage or utility trailers, etc.

800 LBS. WEIGHT DISTRIBUTING HITCH

- Ideal for medium travel trailers, heavy boat trailers, heavy horse trailers

1,200 LBS. WEIGHT DISTRIBUTING HITCH

- Excellent with heavy travel trailers, marine and horse trailers

1,500 LBS. WEIGHT DISTRIBUTING HITCHES

- Great for agricultural, marine and heavy recreational use

STEADi-FLEX® SYSTEM

This weight distributing system is designed with tapered spring bars for a softer ride. Friction sway control material provides for a quiet ride. Wide spring bars, with a simple pin and clip assembly, reduce wear in the head and on the friction pads.



- No drill installation
- Hitch bar included
- Integrated sway control

Light Duty System

- Will fit 6 in. frames with bottom mount couplers (see coupler chart below)

Heavy Duty System

- Will fit 7 in. frames with bottom mount couplers (see coupler chart below)
- 2 in. deeper drop on drawbar



STEADi-FLEX®



66558

Part Number	Description	Gross Trailer Weight (lbs.)	Tongue Weight (lbs.)	Packaging	Master Carton
66557	STEADi-FLEX Light Duty System, Includes Shank, Built-In Friction Sway Control and Hardware (Will Not Fit Trailer Frames that are 2" x 3" or 2" x 3.5")	4,000	400	Boxed	1
66558	STEADi-FLEX Light Duty System, Includes Shank, Built-In Friction Sway Control and Hardware	8,000	600	Boxed	1
66559	STEADi-FLEX Heavy Duty System, Includes Shank, Built-In Friction Sway Control and Hardware	10,000	1,000	Boxed	1
66560	STEADi-FLEX Heavy Duty System, Includes Shank, Built-In Friction Sway Control and Hardware	12,000	1,200	Boxed	1
66561	STEADi-FLEX Heavy Duty System, Includes Shank, Built-In Friction Sway Control and Hardware	14,000	1,400	Boxed	1

NOTES: This pertains to top mount couplers only. Any bottom mount coupler with a 4 in. to 7 in. frame will work without issue. These values are general guidelines for frame sizes and coupler heights assuming straight level installation. Chain loops and other brackets or accessories are included in the Coupler Offset dimension and must be clear of the Coupler Offset area or modified. For intermediate measurement conditions between green and red, ensure at least 3/4 in. clearance between ball mount and trailer frame rail/accessories. For frame rail depth over 5 in., this includes during steering on flat ground.

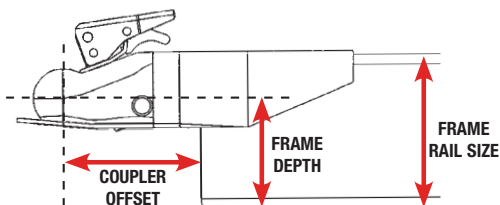

FRAME RAIL SIZE	FRAME DEPTH	COUPLER OFFSET				
		3.5-in	4-in	4.5-in	5-in	5.5-in
4-in Frame	2-in	Green	Green	Green	Green	Green
	3-in	Green	Green	Green	Green	Green
	4-in	Green	Green	Green	Green	Green
5-in Frame	3-in	Green	Green	Green	Green	Green
	4-in	Green	Green	Green	Green	Green
	5-in	Red	Green	Green	Green	Green
6-in Frame	4-in	Green	Green	Green	Green	Green
	5-in	Red	Green	Green	Green	Green
	6-in	Red	Red	Green	Green	Green
7-in Frame	5-in	Red	Green	Green	Green	Green
	6-in	Red	Red	Red	Green	Green
	7-in	Red	Red	Red	Red	Green

STRAIT-LINE® SYSTEM

This is the ultimate hitch in detail and design. The Strait-Line® Hitch was given this name as its pro-active design literally forces the trailer to stay in a straight line behind the tow vehicle. Sway is controlled by the Dual Cam High-Performance System. The stronger the sway force, the more the Dual Cam System works to stop it. The Strait-Line® Hitch consists of our patented Dual Cam High-Performance Sway Control combined with our High-Performance Weight Distributing System in one easy-to-install package. The Strait-Line® Hitch literally forces the trailer to stay in a straight line behind the tow vehicle. Sway is controlled by the Dual Cam High-Performance System; The stronger the sway force, the more the Dual Cam System works to stop it.

- The Strait-Line® Hitch combines weight distributing with the best pro-active sway control system available in a newly-designed, easy-to-install kit
- Simple installation and adjustment
- Fully automatic and self-centering
- Reduced noise
- No U-bolts to interfere with bottle racks or other A-Frame mounted items
- Specific attachment reference points provided
- Easy adjustment of centerline
- No need to relocate items on top of A-Frame to install Dual Cam High-Performance Sway Control



66072

Part Number	Description	Style	Gross Trailer Weight (lbs.)	Weight Distributing Kit Included	Sway Control Included	Shank Included	Packaging	Master Carton
66072	Strait-Line 600 System	Trunnion Bar	600	66020	26002	-	Boxed	1
66082	Strait-Line 600 System	Trunnion Bar	600	66540	26002	54970	Boxed	1
66073	Strait-Line 800 System	Trunnion Bar	800	66021	26002	-	Boxed	1
66083	Strait-Line 800 System	Trunnion Bar	800	66541	26002	54970	Boxed	1
66074	Strait-Line 1,200 System	Trunnion Bar	1,200	66022	26002	-	Boxed	1
66084	Strait-Line 1,200 System	Trunnion Bar	1,200	66542	26002	54970	Boxed	1
66130	Strait-Line 1,500 System for Ultra Frame Receivers	Trunnion Bar	1,500	66131	26002	-	Boxed	1
66075	Strait-Line 1,700 System for 2-1/2" Receivers	Trunnion Bar	1,700	66006	26002	-	Boxed	1

HIGH PERFORMANCE TRUNNION STYLE SYSTEM

REESE® has combined the best of the features from all of our weight distributing kits to create the High-Performance Trunnion Kit. It includes a head design with superior strength and easy adjustment. The head includes a forged raised ball platform and forged Trunnion mounts. The channel of the head utilizes our “serrated washer” design. The serrated washers make it easier to dial in the set up of the High-Performance Weight Distributing Kit. In addition to the changes in the head, the High-Performance Weight Distributing Kit includes the highest rated spring bars per class in the industry. They also feature an integrated cam for easy set up with the optional Dual Cam High-Performance Sway Control. Other features include 9-link chains for easier set up on larger trailer frames and innovative snap-up brackets designed for superior strength and durability.

- Raised hitch ball platform eliminates the need for raised hitch balls
- Easy-to-use serrated washers for head adjustment



66540

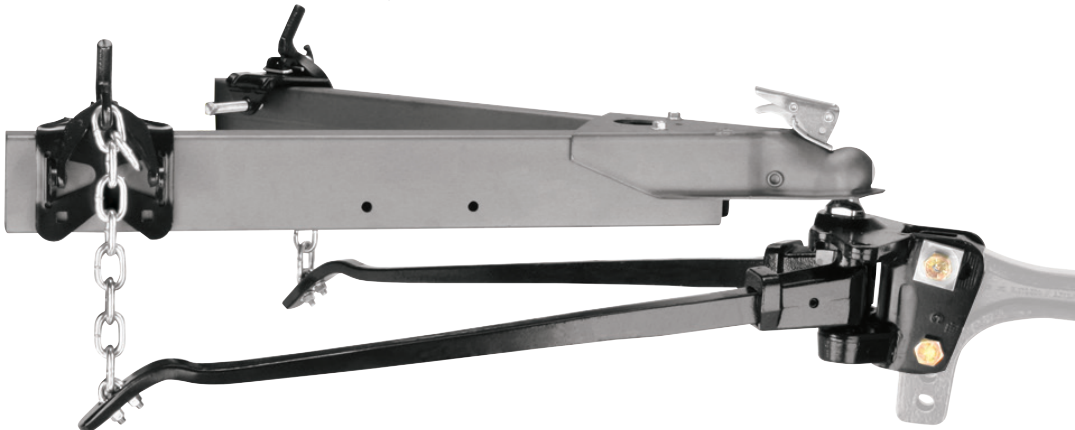

Part Number	Description	Gross Trailer Weight (lbs.)	Tongue Weight (lbs.)	Shank Included	Packaging	Master Carton
66020	High Performance Trunnion Style System	10,000	600	-	Boxed	1
66540	High Performance Trunnion Style System	10,000	600	54970	Boxed	1
66021	High Performance Trunnion Style System	10,000	800	-	Boxed	1
66541	High Performance Trunnion Style System	10,000	800	54970	Boxed	1
66022	High Performance Trunnion Style System	12,000	1,200	-	Boxed	1
66542	High Performance Trunnion Style System	12,000	1,200	54970	Boxed	1
66131	High Performance Trunnion Style System for Ultra Frame Receivers	15,000	1,500	-	Boxed	1
66540	High Performance Trunnion Style System	15,000	1,500	54970	Boxed	1
66006	High Performance Trunnion Style System	17,000	1,700	-	Boxed	1

U.S. Patent Nos. 5,375,867 and 5,465,991, other patents pending

Dual Cam HP



26002

DUAL CAM HIGH PERFORMANCE SWAY CONTROL

Patented technique for controlling trailer sway. Works when needed to control sway from the start rather than just resisting. The Dual Cam System is installed on the trailer and does not normally require adjustment every time the towing vehicle and trailer are hooked up.

- Integrated cams into the spring bars reduce noise
- No U-bolts to interfere with bottle racks or other A-Frame mounted items
- Specific attachment reference points provided
- Fits most applications



Part Number	Description	Packaging	Master Carton
26002	Dual Cam High Performance Sway Control	Boxed	1
58507	Dual Cam Accessory, (4) Rivet Nuts for Tube Frames	Boxed	1



83660

NOTE: Weight distributing hitch not included; use of sway controls with surge brakes not recommended; this product is recommended to be used with weight distribution that has the integrated spring bars only

FRICTION SWAY CONTROL

- Installs and removes easily
- Removes with two spring locking pins
- Heavy construction for added reliability
- Friction brake keeps trailer and tow vehicle stable
- Quick attachment to trailer frame and ball mount
- Can be used on left and right side of trailer

Part Number	Description	Packaging	Master Carton
83660	Friction Sway Control	Litho Box	1
3442	Weld-On Sway Control Adapter	Bulk	1
Replacement Parts			
58060	Sway Control Ball, 1-1/4" x 5/8"	Poly Bag	1
58062	Ball Plate Assembly	Boxed	1

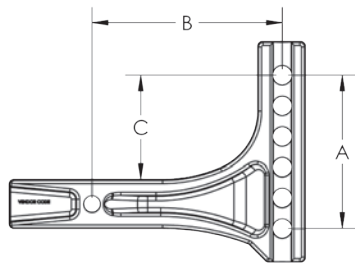

RISE POSITION

A= Height C= Rise
B= Length D= Drop

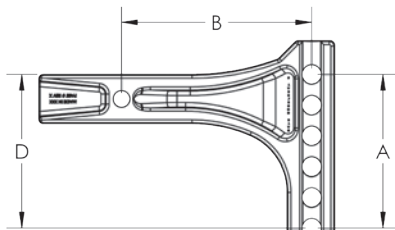

DROP POSITION

WEIGHT DISTRIBUTION HITCH BARS

- Weight Distributing hitch bars offer a full range of style and adjustability
- Designed for use with all trunnion and round bar weight distributing kits
- Angled, extended, "T" and deep drop designs available
- Designed for use in the rise or drop position
- 2 in. shank
- Refer to the diagrams to assist in determining the correct length, rise and drop required for your weight distributing hitch

Part Number	TW Capacity (lbs.)	(A) Height (in.)	(B) Length (in.)	(C) Rise (in.)	(D) Drop (in.)	Style	Packaging	Master Carton
63911	1,200	6-1/4	7-3/4	4-1/4	6-1/4	Cast	Boxed	1
54970	1,500	6-1/4	9-1/4	4-1/4	6-1/4	Cast	Boxed	1
	1,000	6-1/4	10-1/4	4-1/4	6-1/4			
3214	1,400	6-1/4	11-3/4	4-1/4	6-1/4	Welded	Boxed	1
3215	1,400	6-1/4	8-3/4	8-3/4	10-3/4	Welded	Boxed	1
3344	1,400	5	8-3/4	-	13-1/4	Welded	Boxed	1
63971	1,500	7-1/2	9-3/4	-	10	Cast	Boxed	1
54998	1,600	7-1/2	9-1/4	4-7/8	6-7/8	Cast	Boxed	1

NOTE: Do not exceed tow vehicle, hitch or equipment rating

POLE TONGUE ADAPTERS

A pole tongue adapter is used as a mounting platform for the lift brackets of a weight distributing hitch system when a trailer has a pole or straight tongue rather than an A-Frame tongue.

- Fits all lift units regardless of manufacturer
- Fits tongue widths from 1-5/8 in. to 5 in.
- Fits tongue heights from 3 in. to 6 in.



3280

Part Number	Description	Gross Trailer Weight (lbs.)	Tongue Weight (lbs.)	Packaging	Master Carton
3280	Pole Tongue Adapter and Fastener Kit	7,500	750	Boxed	1
58393	Pole Tongue Adapter and Fastener Kit			Boxed	1
	-Mounted on Top Tongue	14,000	1,400		
	-Mounted Below Tongue	12,000	1,200		

NOTE: Not for use with light duty weight distributing hitch



26003 / 26005

BOLT-ON MOUNTING ADAPTERS FOR SWAY CONTROL

- Easy bolt-on installation
- Black powder coat finish over E-coat

Part Number	Description	Packaging	Master Carton
26003	Sway Control Adapter Bracket for Class III and IV, 2" Ball Mounts	Poly Bag	1
26005	Sway Control Adapter Bracket for Class II, 1-1/4" Drawbars	Poly Bag	1

NOTE: 26003 cannot be used with Class I or Class II Drawbars. 26005 cannot be used with Class I Drawbars. Ball platform does not prevent adapter from turning during tightening.



54980

ADJUSTABLE BALL MOUNTS WITH HITCH BARS

Part Number	Description	Packaging	Master Carton
54980	Adjustable Ball Mount with Hitch Bar 54790	Boxed	1
54994	Adjustable Ball Mount with Hitch Bar 54998	Boxed	1



58392

SNAP-UP BRACKETS

- Rugged positive locking design
- Unit locks using safety pin (55180)
- Narrower, for increased frame clearance
- One-piece cast chain hook
- Black powder coat finish over E-coat

Part Number	Description	Packaging	Master Carton
6637	Snap-Up Bracket Assembly Kit with Handle (2 Piece)	Boxed	1
58162	Snap-Up Handle	Boxed	1
21501	Snap-Up Bracket with Set Screw and Safety Pin	Bulk	1
58392	Snap-Up Bracket with Set Screw and Safety Pin for use with Weight Distribution Systems with Tongue Weights 800 lbs. and Over	Boxed	1



58306

CHAIN HANGERS

For trailers with tongue interference (gas bottles, batteries, covered frames, etc.) where snap-up brackets (21501) won't install easily, we offer two easy-to-install options.

- Black powder coat finish over E-coat
- Includes hardware

Part Number	Description	Gross Trailer Weight (lbs.)	Tongue Weight (lbs.)	Packaging	Master Carton
58305	Chain Hanger, Bolt-On	14,000	1,400	Boxed	1
58306	Chain Hanger, Clamp-On	14,000	1,400	Boxed	1



5780

SHERLINE TRAILER TONGUE WEIGHT SCALE

- Sherline is a hydraulic pressure gauge for measuring trailer tongue weights from 0 to 2,000 lbs.

Part Number	Description	Packaging	Master Carton
5780	Sherline Trailer Tongue Weight Scale	Boxed	1

REPLACEMENT PARTS

STEADI-FLEX® WEIGHT DISTRIBUTION REPLACEMENT PARTS

- Part Numbers: Light Duty Systems: 66557 and 66558 Heavy Duty Systems: 66559, 66560 and 66561

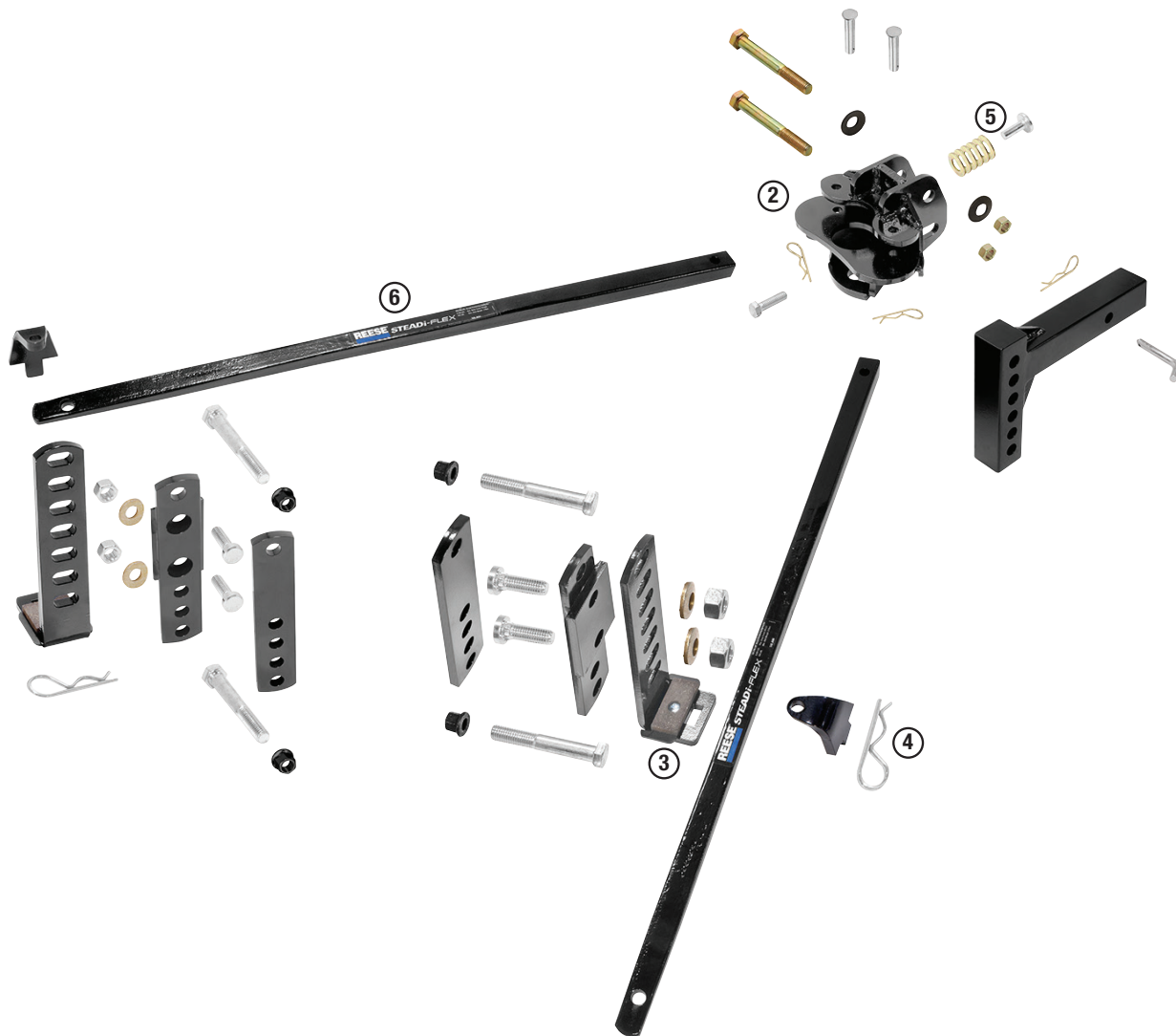

Part Number	Ref.	Qty.	Description	Packaging	Master Carton
58513	2	1	Ball Mount with Hardware for Light Duty Systems	Poly Bag	1
58497	4	2	Friction Pads with Hardware for Light Duty Systems	Poly Bag	1
58498	4	1	Retention Bracket with Clip for Light Duty Systems	Poly Bag	1
58499	5	1	Ball Mount Adjustment Washers and Pin for Light Duty Systems	Poly Bag	1
58500	6	1	Spring Bar with Pin and Clip 400 lbs.	Poly Bag	1
58501		1	Spring Bar with Pin and Clip 600 lbs.	Poly Bag	1
58527		1	Friction Pad Kit for Heavy Duty Systems	Poly Bag	1
58528		1	Ball Mount with Hardware for Heavy Duty Systems	Poly Bag	1

ROUND BAR WEIGHT DISTRIBUTION REPLACEMENT PARTS

• Part Numbers: 65509†, 67509† and 61009†



† = Available while supplies last

Part Number	Ref.	Qty.	Description
55010	3	1	Pull Pin
55515	4	1	Spring clip
21501	23	1	Snap-Up Bracket
	17	1	Set Screw
	24	1	Safety Pin
58392		1	Snap-Up Bracket with Set Screw and Safety Pin (for use with Weight Distribution Systems with Tongue Weight 800 lbs. and Over)
66014	3	1	Pull Pin
	4	1	Spring Clip
	5	1	Reducer Bushing 1-1/4" to 1"
	17	2	Square Head Set Screw (1/2"-13 x 3-1/2")
	24	2	Safety Pins
	19	2	U-Bolts (3/8" Attaches Chain to Spring Bar)
	18	2	Chains: 11 Link (8/0)
	20	4	Lock Nuts (3/8"-16)
55630	19	1	U-Bolts (3/8" Attaches Chain to Spring Bar)
	18	1	Chains: 11 Link (8/0)
	20	2	Lock Nuts (3/8"-16)
	21	2	Flat Washers (3/8")

Part Number	Ref.	Qty.	Description
55180	24	2	Safety Pins (1 per Box)
58032	19	2	U-Bolts (3/8" Attaches Chain to Spring Bar)
	20	4	Lock Nuts (3/8"-16)
	21	4	Flat Washers (3/8")
54970	1	1	Adjustable Hitch Bar (12")
58184	5	1	Reducer Bushing 1-1/4" to 1"
58162	25	1	Handle for Snap-Up Bracket
58112	2	1	Ball Mount (REESE Only)
	5	1	Reducer Bushing 1-1/4" to 1"
	10	2	Split Lock Washers
	6	2	HHC Screws (3/4"-10 x 5")
	9	2	Flat Washers (3/4"-Hardened)
	7	2	Hex Nuts (3/4"-10)
	8	2	Adjustment Washers
		1	Installation Instructions
58114	28	1	800 lbs. Spring Bar
58115	1	1	1,200 lbs. Spring Bar

REPLACEMENT PARTS

TRUNNION BAR WEIGHT DISTRIBUTION REPLACEMENT PARTS

• Part Numbers: 66540†, 66541†, 66542†, 66020†, 66021†, 66022†, 66131† and 66006†



† = Available while supplies last

Part Number	Ref.	Qty.	Description
55010	3	1	Pull Pin
55515	4	1	Spring Clip
21501	23	1	Snap-Up Bracket
	17	1	Set Screw
	24	1	Safety Pin
58392		1	Snap-Up Bracket with Set Screw and Safety Pin (for use with Weight Distribution Systems with Tongue Weight 800 lbs. and Over)
66014	3	1	Pull Pin
	4	1	Spring Clip
	5	1	Reducer Bushing 1-1/4" to 1"
	17	2	Square Head Set Screw (1/2"-13 x 3-1/2")
	24	2	Safety Pins
	19	2	U-Bolts (3/8" Attaches Chain to Spring Bar)
	18	2	Chains: 11 Link (8/0)
	20	4	Lock Nuts (3/8"-16)
	21	4	Flat Washers (3/8")
55630	19	1	U-Bolts (3/8" Attaches Chain to Spring Bar)
	18	1	Chains: 11 Link (8/0)
	20	2	Lock Nuts (3/8"-16)
	21	2	Flat Washers (3/8")
58024	33	2	Replacement Adjusting Washers
55180	24	2	Safety Pins (1 per Box)
58033	17	2	Square Head Bolt (1/2"-13 x 3-1/2")
58032	19	2	U-Bolts (3/8" Attaches Chain to Spring Bar)
	20	4	Lock Nuts (3/8"-16)
	21	4	Flat Washers (3/8")

Part Number	Ref.	Qty.	Description
58167	36	1	Ball Mount (REESE Only)
	5	1	Reducer Bushing 1-1/4" to 1"
	31	1	HH Cap Screw (3/4" x 5.5")
	32	2	Hex Nuts (3/4")
	33	2	Adjusting Washers
	34	1	HH Cap Screw (3/4" x 4.5")
	35	2	Split Lock Washer (3/4")
54970	1	1	Adjustable Hitch Bar (12"), 1,500 lb. Rating
54977	1	1	Adjustable Hitch Bar for #66006, 15" 1,700 lbs. Rating
58184	5	1	Reducer Rushing: 1-1/4" to 1"
58162	25	1	Handle for Snap-Up Bracket
58369		1	1,500 lbs. Spring Bar and Trunnion
23227	30	1	600 lbs. Spring Bar and Trunnion
22225		1	800 lbs. Spring Bar and Trunnion
66009		1	1,200 lbs. Spring Bar and Trunnion
66010		1	1,700 lbs. Spring Bar and Trunnion
58097	11	1	1-3/8" Trunnion and Pin
58098	11	1	1-1/8" Trunnion and Pin
58133	35	2	Lock Washers
	31	1	HHC Screw (3/4" x 5.5")
	34	1	HHC Screw (3/4" x 4.5")
	33	2	Adjustable Serrated Washers
	32	2	Hex Nuts
58459		1	Threaded Screw Service Kit, Under Mount Couplers Only
58032	19	2	U-Bolts (3/8" Attaches Chain to Spring Bar)

RB2 AND RB3 WEIGHT DISTRIBUTION REPLACEMENT PARTS

• Part Numbers: 49568†, 49569† and 49570†



† = Available while supplies last

Part Number	Ref.	Qty.	Description
55010	3	1	Pull Pin
55515	4	1	Spring Clip
58362	23	1	Frame Bracket Assembly (Snap-Up)
	17	1	Square Head Bolt (1/2"-13 x 3-1/2")
	24	1	Safety Pin
58364	19	1	U-Bolt (3/8" Attaches Chain to Spring Bar)
	18	1	Chain – 9 Link (8/0)
	20	2	Lock Nuts (3/8"-16)
	21	2	Flat Washers (3/8")
55180	24	2	Safety Pins (1 per Box)
54970	1	1	Adjustable Hitch Bar (12")
55030	5	1	Reducer Bushing 1-1/4" to 1"
58162	25	1	Handle for Snap-Up Bracket
58339	5-10	1	Hardware Bag for Ball Mount

Part Number	Ref.	Qty.	Description
58333	2	1	Ball Mount
	5	1	Reducer Bushing 1-1/4" to 1"
	10	2	Split Lock Washers
	6	2	HHC Screws (3/4"-10 x 5")
	9	2	Flat Washers (3/4"-Hardened)
	7	2	Hex Nuts (3/4"-10)
	8	2	Adjustment Washers
			1
58336	28	1	600 lbs Spring Bar
58337		1	800 lbs. Spring Bar
58338		1	1,200 lbs. Spring Bar
58439		1	550 lbs. Spring Bar without Bend
58440		1	750 lbs. Spring Bar without Bend
58441		1	1,000 lbs. Spring Bar without Bend
58442		1	Bolt Together Head
58444		1	Bolt Together Shim Kit

REPLACEMENT PARTS

FRICTION SWAY CONTROL REPLACEMENT PARTS

• Part Number: 83660

③ (Spring Clip Only)



Part Number	Ref.	Qty.	Description	Packaging	Master Carton
58060	1	1	Ball Assembly (Includes Ball, Washer, and Nut)	Poly Bag	1
58062	2	1	Ball Plate and Mounting Screws	Poly Bag	1
55515	3	2	Spring Clip	Poly Bag	1

DUAL CAM HP SWAY CONTROL REPLACEMENT PARTS

• Part Number: 26002

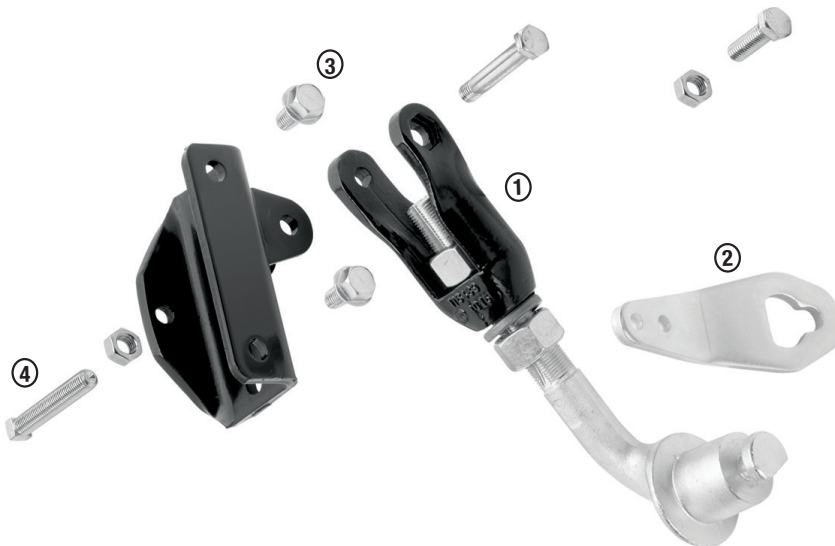

Part Number	Ref.	Qty.	Description	Packaging	Master Carton
58435	1	2	Service Kit - Cam Arm with (2) 1-14" Adjustable Hex Nuts and Washers	Poly Bag	1
58192	2	2	Chain Hanger Bracket	Poly Bag	1
58437	3	8	1/2"-13 Thread Forming Screw	Poly Bag	1
58033	4	2	Service Kit - Snap-Up	Poly Bag	1



66088†

STRAIT-LINE® SYSTEM

LAST CHANCE

Part Number	Description	GTW (lbs.)	TW (lbs.)	Substitute Part Number	Packaging	Master Carton
66086†	Includes Sway Control and Shank	6,000	600	66082	Boxed	1
66087†	Includes Sway Control and Shank	8,000	800	66083	Boxed	1
66088†	Includes Sway Control and Shank	12,000	1,200	66804	Boxed	1

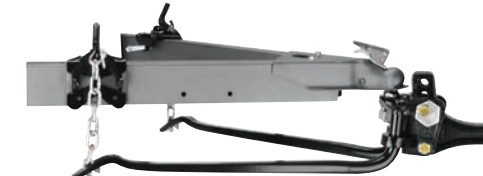

61009†

HEAVY DUTY ROUND BAR

LAST CHANCE

Part Number	Description	GTW (lbs.)	TW (lbs.)	Substitute Part Number	Packaging	Master Carton
65509†	Includes Sway Control and Shank	10,000	600	66558	Boxed	1
67509†	Includes Sway Control and Shank	10,000	800	66559	Boxed	1
61009†	Includes Sway Control and Shank	12,000	1,200	66560	Boxed	1



49568†

RB2 AND RB3 ROUND BAR

LAST CHANCE

Part Number	Description	GTW (lbs.)	TW (lbs.)	Substitute Part Number	Packaging	Master Carton
49568†	RB2, Includes Shank	10,000	600	66558	Boxed	1
49569†	RB2, Includes Shank	10,000	800	66559	Boxed	1
49570†	RB2, Includes Shank	12,000	1,200	66560	Boxed	1
49581†	RB3, Includes Shank	10,000	550	66558	Boxed	1
49582†	RB3, Includes Shank	10,000	750	66558	Boxed	1
49583†	RB3, Includes Shank	10,000	1,000	66559	Boxed	1



65509†

COMPLETE ROUND BAR KIT

LAST CHANCE

Part Number	Description	GTW (lbs.)	TW (lbs.)	Substitute Part Number	Packaging	Master Carton
49901†	Includes Friction Sway Control and Shank	10,000	550	66558	Boxed	1
49902†	Includes Friction Sway Control and Shank	10,000	750	66559	Boxed	1
49903†	Includes Friction Sway Control and Shank	10,000	1,000	66560	Boxed	1
49904†	Includes Friction Sway Control and Shank	10,000	1,200	66560	Boxed	1
65509†	Includes Friction Sway Control and Shank	10,000	600	66558	Boxed	1
67509†	Includes Friction Sway Control and Shank	10,000	800	66559	Boxed	1
61009†	Includes Friction Sway Control and Shank	12,000	1,200	66560	Boxed	1



54977†

WD SHANKS

LAST CHANCE

Part Number	Description	Substitute Part Number	Packaging	Master Carton
54977†	Weight Distribution Shank, 1,700 lbs. Capacity, 2-1/2" Diameter, 11-1/2" Length, 7-3/4" Rise, 10-1/4" Drop	3215	Boxed	1
54976†	Weight Distribution Shank, 1,700 lbs. Capacity, 2-1/2" Diameter, 11-1/2" Length, 1-1/4" Rise, 5-1/4" Drop	54998	Boxed	1

† = Available while supplies last



FIFTH WHEEL HITCHES

Founded in 1952, the REESE® brand has become a household name in the heavy-duty towing industry. With proven designs that exceed the industry standards, REESE® has become the brand of choice when performance is the expectation.

The core product line of REESE® is the heavy duty fifth wheels which provide safe towing for the weekend warriors and the seasoned campers.

M5 SERIES

20K and 27K F-2

STANDARD SERIES

16K F-3

20K Drop in for RAM F-3

20K F-4

30K Low Profile F-4

MOUNTING RAILS AND BRACKETS F-5

ABOVE-BED GOOSENECK HITCHES

Hi-Rise™ Conversion Hitch F-5

Elite™ Series F-6

The Goose™ F-6

Standard Series F-6

FIFTH WHEEL ACCESSORIES

Sliders F-7

Lube Plates F-8

Locks F-7 - F-8

APPLICATION GUIDES

Custom Install Brackets F-9

Outboard Rails F-10

Universal Rail Kits F-11

Vertical Hitch Adjustment Chart F-12

REPLACEMENT PARTS F-13 - F-18

DISCONTINUED PRODUCTS F-19 - F-20

20K



30928

27K



30929



30892



30894

M5 SERIES FIFTH WHEEL HITCH

Experience the quietest and smoothest tow possible thanks to a wider stance, tighter tolerances, and industry leading shock dampening system. By combining the latest in technology, rugged endurance, and sleek design, the M5 continues the REESE® legacy of Pioneering Performance.



- 20,000 lbs. capacity / 5,000 lbs. pin weight capacity
27,000 lbs. capacity / 6,750 lbs. pin weight capacity
- Exclusive Talon™ Jaw - always ready-to-receive jaw grips the pin to eliminate lateral chucking, reducing sway and noise
- High-pin lock out prevents false indication of a safe connection
- Ergonomic easy-reach handle and low effort Talon™ Jaw System
- Exclusive independent pivot bushing technology decreases fore and aft movement for the quietest fifth wheel on the market
- Wide stance allows connection as close to the frame as possible for a solid, stable tow
- Offset center section for additional clearance between cab and trailer
- Easy hook-up - clear Tow/No Tow indicator
- SAE J2638 Compliant



Part Number	Application	Capacity (lbs.)	Vertical Adjustment (in.)	Packaging	Master Carton
20K Complete Hitch System					
30921	Ford (OE Puck System)	20,000	14 to 18	Boxed	1
30890	GM (OE Puck System)	20,000	14 to 18	Boxed	1
30918	RAM (OE Puck System)	20,000	14 to 18	Boxed	1
30928	Standard Industry Rails	20,000	14 to 18	Boxed	1
27K Complete Hitch System					
30922	Ford (OE Puck System)	27,000	14 to 18	Boxed	1
30895	GM (OE Puck System)	27,000	14 to 18	Boxed	1
30919	RAM (OE Puck System)	27,000	14 to 18	Boxed	1
30929	Standard Industry Rails	27,000	14 to 18	Boxed	1
Center Section Only					
30884	Ford, GM, RAM and Standard Industry Rails, for 20K Hitches			Boxed	1
30894	Ford, GM, RAM and Standard Industry Rails, for 27K Hitches			Boxed	1
Hitch Head Only					
30892	Ford, GM, RAM and Standard Industry Rails			Boxed	1
Legs Only					
30923	Ford, for 20K and 27K Hitches			Boxed	1
30889	GM, for 20K and 27K Hitches			Boxed	1
30917	RAM, for 20K and 27K Hitches			Boxed	1
30926	Standard Industry Rails, for 20K Hitches			Boxed	1
30927	Standard Industry Rails, for 27K Hitches			Boxed	1
Accessories and Replacement Parts					
58563	M5 Series Anti-Rattle Kit			Poly Bag	1
58553	M5 Series Low Profile Handle Assembly			Poly Bag	1

NOTE: Will not fit trucks with beds shorter than 6 ft. length unless trailer is equipped with a Sidewinder

16K



30047



30075

16K FIFTH WHEEL HITCH

- 16,000 lbs. capacity / 4,000 lbs. pin weight capacity
- Two-jaw locking system featuring side-to-side pivot action to better accommodate hook-ups on uneven ground
- Quick installation, strong performance and easy removal allows full access to the truck bed
- Fore-and-aft and side-to-side 4° - 5° pivot
- Locking jaw handle
- Wide stance one-piece legs for improved stability
- Rails and installation kit sold separately (30035)



Part Number	Description	Capacity (lbs.)	Vertical Adjustment (in.)	Packaging	Master Carton
30047	16K Fifth Wheel	16,000	13-1/2 to 17	Boxed	1
30051	16K Fifth Wheel with Square Tube Slider	16,000	14-3/4 to 17	Boxed	1
30075	16K Fifth Wheel with Round Tube Slider	16,000	15-1/2 to 7-3/4	Boxed	1
Replacement Parts					
30047A	16K Head with Head Support and Hardware			Boxed	1
58146	16K Head Only, Service Kit			Boxed	1
58147	16K Cross Member, Head Support Only			Boxed	1
30727	16K Legs Only			Boxed	1
58521	16K Head Assembly Hardware, Includes: (1) Cotter Pin, (2) Rubber Bumpers, (4) Locknuts 1/2" - 13, (4) Hex Bolts 1/2" - 13 x 4-1/2" Grade 5, (2) Nuts 8 - 32, (4) Spring Clips, (2) Machine Screws 8 - 32 x 1" and (4) Pull Pins			Poly Bag	1
58484	16K Pivot Pin			Poly Bag	1

NOTE: Will not fit trucks with beds shorter than 6 ft. length unless trailer is equipped with a Sidewinder. Will not fit trucks with flareside/stepside

20K



30160

FIFTH WHEEL DROP-IN FOR RAM 2500 HD AND 3500 HD

- 20,000 lbs. capacity / 5,000 lbs. pin weight capacity
- Built-in handles for easy, safe installation and removal
- Built with Elite™ Series fifth wheel head
- Direct fit for RAM trucks with OE tow package
- SAE J2638 Compliant



Part Number	Description	Capacity (lbs.)	Vertical Adjustment (in.)	Packaging	Master Carton
30160	Fifth Wheel Drop-In for '13-19 RAM 2500 HD and 3500 HD with Factory Installed OE Rail System	20,000	14-1/4 to 18	Boxed	1
Replacement Parts					
30863	RAM Drop-In Center Section			Boxed	1
30864	RAM Drop-In Base Arches			Boxed	1
117300	Elite Series Head Kit			Boxed	1

NOTE: Will not fit trucks with beds shorter than 6 ft. length unless trailer is equipped with a Sidewinder. Will not fit trucks with flareside/stepside

20K

20K FIFTH WHEEL HITCH

- 20,000 lbs. capacity / 5,000 lbs. pin weight capacity
- Full floating head for improved hooking/unhooking, as well as ride performance
- Dual jaw system completely surrounds the king pin for significantly reduced wear
- Lubricated and clamped side joints for tight and efficient operation
- Lightweight, easy to install and remove
- One-piece formed legs, provides a wider footprint for superior stability
- Sidewinder™ compatible, preferred for short bed pickups
- Compatible slider system available
- Rails and installation kit sold separately (30035)



30119



30132

Part Number	Description	Capacity (lbs.)	Vertical Adjustment (in.)	Packaging	Master Carton
30118	20K Fifth Wheel Head and Support	20,000	-	Boxed	1
30119*	20K Fifth Wheel Head, Support and Legs	20,000	13-1/2 to 17	Boxed	1
30132*	20K Fifth Wheel Head, Support, Legs and Rails	20,000	14-1/2 to 17	Boxed	1
Replacement Parts					
58472	20K Fifth Wheel Cross Member			Boxed	1
58473	20K Fifth Wheel Handle Assembly			Poly Bag	1
58474	20K Fifth Wheel Pivot Shaft, Shaft Nut and Cotter Pin			Poly Bag	1
58475	20K Fifth Wheel Hardware			Poly Bag	1

NOTE: Will not fit trucks with beds shorter than 6 ft. length unless trailer is equipped with a Sidewinder. Will not fit trucks with flareside/stepside

30K

30K LOW PROFILE FIFTH WHEEL HITCH

- 30,000 lbs. capacity / 7,500 lbs. pin weight capacity
- Low profile design can be vertically adjusted 3 in. to permit level trailering
- Side-tilt design reduces vehicle frame stress, creating a smoother, more comfortable ride
- Designed and engineered for the serious tower, primarily on medium-duty conversion trucks
- Actuating handle is easily accessible, making hook-up quicker and more convenient



30054

Part Number	Description	Capacity (lbs.)	Vertical Adjustment (in.)	Packaging	Master Carton
30054	30K Low Profile Fifth Wheel, Base Rails Not Used, Mounts Directly to Medium-Duty Truck	30,000	9-1/2 to 12-1/2	Boxed	1

NOTE: Will not fit trucks with beds shorter than 6 ft. length unless trailer is equipped with a Sidewinder. Will not fit trucks with flareside/stepside

20K



30156

OEM TO INDUSTRY STANDARD RAIL MOUNTING ADAPTERS

- 20,000 lbs. capacity / 5,000 lbs. pin weight capacity
25,000 lbs. capacity / 6,500 lbs. pin weight capacity
- The robust REESE® adapter will not touch or scratch the truck bed
- Uses the fast and secure REESE® patented latching system
- Built-in handles for safe, easy installation and removal
- SAE J2638 Compliant



Part Number	Description	Capacity (lbs.)	Pin Capacity (lbs.)	Packaging	Master Carton
30156	Rail Kit Mounting Adapter for '11-19 Ford OEM and all Elite Series Under-Bed Rail Kits, Works with any 15K, 16K or 20K Fifth Wheel Hitch	20,000	5,000	Boxed	1
30154	Rail Kit Mounting Adapter for '13-19 RAM 2500 HD and 3500 HD with Factory Installed OE Mounting System, Works with any Standard Fifth Wheel Hitch up to 25K	25,000	6,500	Boxed	1

25K



30154

18K



9480

HI-RISE™ CONVERSION HITCH

- Converts a gooseneck hitch into a fifth wheel hitch
- 18,000 lbs. capacity / 4,500 lbs. pin weight capacity
- 4-way pivoting head with self latching jaw design
- 4 degree side-to-side pivot for better control
- 2 bolts for bed height adjustments
- Offset legs enhance performance while braking
- Adjustable stabilizer strips fit bed corrugation pattern
- Lockable, extended length handle
- Only works with B&W gooseneck hitch and REESE® (94XX) series heads utilizing (44XX) series rails

Part Number	Description	Capacity (lbs.)	Vertical Adjustment (in.)	Packaging	Master Carton
9480	Hi-Rise Conversion Hitch	18,000	14-1/4 to 18	Boxed	1
Replacement Parts					
58438	Stabilizer Strips			Boxed	1
117300	Elite Fifth Wheel Head Kit			Boxed	1

NOTE: Not rated for use with Sidewinder

25K



30845

ELITE™ SERIES ABOVE-BED GOOSENECK HITCH



- 25,000 lbs. capacity
- 2-5/16 in. high strength zinc plated ball
- Specifically designed for those who employs both fifth wheel and gooseneck trailers
- Mounts to all Elite™ Series Rail Kits
- Above-Bed Gooseneck can be easily removed for unobstructed use of the truck bed
- Weather resistant plastic covering provides protection from the elements and aesthetic appeal
- Built-in chain bracket to accommodate safety chain



Part Number	Description	Capacity (lbs.)	Pin Capacity (lbs.)	Packaging	Master Carton
30845	Elite Series Gooseneck Hitch	25,000	6,250	Boxed	1
Replacement Parts					
58419	Elite Series Gooseneck Service Kit when used on Elite Rail Kits and Ford OEM Under Bed			Boxed	1

NOTE: Will not fit trucks with flareside/stepsides

25K



58079

THE GOOSE® ABOVE-BED GOOSENECK HITCH

- In-truck platform rated for 25,000 lbs. gross vehicle towing weight and 6,250 lbs. vertical load
- Easy installation and removal allows for full access to truck bed
- Utilizes same base rails as our fifth wheel hitches
- 2-5/16 in. high strength zinc plated ball
- Rails and installation kit sold separately (30035)



Part Number	Description	Capacity (lbs.)	Pin Capacity (lbs.)	Packaging	Master Carton
58079	The Goose Above-Bed Gooseneck Hitch	25,000	6,250	Boxed	1
58208	Chevrolet Composite Bed Kit for Gooseneck			Boxed	1

25K



49080

STANDARD ABOVE-BED GOOSENECK HITCH

- In-truck platform rated for 25,000 lbs. gross vehicle towing weight and 6,250 lbs. vertical load
- Easy installation and removal allows for full access to truck bed
- Utilizes same base rails as our fifth wheel hitches
- Ball is offset 2 in. to accommodate 6 ft. and 8 ft. truck beds
- 2-5/16 in. high strength zinc plated ball
- Rails and installation kit sold separately (30035)



Part Number	Description	Capacity (lbs.)	Pin Capacity (lbs.)	Packaging	Master Carton
49080	Standard Above-Bed Gooseneck Hitch	25,000	6,250	Boxed	1
58208	Chevrolet Composite Bed Kit for Gooseneck			Boxed	1

20K

ROUND TUBE SLIDER

- 20,000 lbs. capacity / 10 in. travel fore-and-aft
- Slider system re-engineered to be the best in the industry
- Slider systems expanded to give true ease and precision
- Contoured rollers float from side to side to accommodate mounting systems that may not be fully square
- Embossed roller supports for low friction and longer wear
- Forged mounting feet for wide consistent attachment to rails
- Updated pin mounting holes to better align with the industry standard rail kits and reduce play
- Plated rails hold up longer for extended wear
- New customized grip
- Rails and installation kit sold separately (30035)
- SAE J2638 Compliant



50024



Part Number	Description	Capacity (lbs.)	Packaging	Master Carton
50024	Round Tube Slider	20,000	Boxed	1
Replacement Parts				
58493	Round Tube Slider Handle, Grip, Roll Pin and Cotter Pins		Boxed	1
50048	Round Tube Slider, Detent Lock Pin and Lanyard		Boxed	1

NOTE: Check clearance between king pin bed and tailgate before moving to maneuvering position

20K

KWIK-SLIDE® SQUARE TUBE SLIDER

- 20,000 lbs. capacity / 10 in. travel fore-and-aft
- Minimum 13 in. extended trailer pin box recommended
- 6 roller design
- Works with full size truck and compact trucks
- Fully adjustable with trailer attached
- Rails and installation kit sold separately (30035)



30048



Part Number	Description	Capacity (lbs.)	Packaging	Master Carton
30048	Kwik-Slide Square Tube Slider	20,000	Boxed	1
Replacement Parts				
58161	Square Tube Slider Handle Kit, Includes: (1) Latch Shaft, (1) Handle Grip, (1) Head Assembly, (2) Cotter Pins 5/32" x 1" and (1) Roll Pin 3/16" x 2"		Boxed	1

NOTE: Check clearance between king pin bed and tailgate before moving to maneuvering position

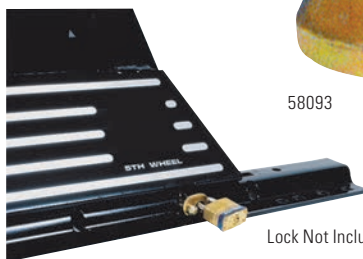

Lock Not Included

58093



PULL PIN LOCK PLATES

- Prevents theft of fifth wheel and unwanted removal of pull pins
- Add a standard padlock to make the locking plate a security device

Part Number	Description	Packaging	Master Carton
58093	Pin Lock Plates for 1/2" Pull Pins, (4 Pack)	Boxed	1

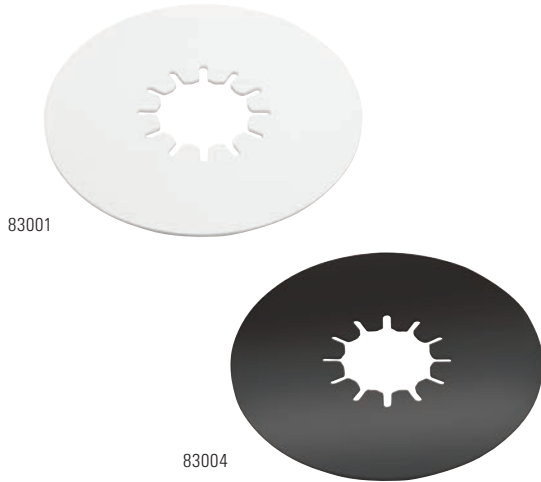

FIFTH WHEEL LUBE PLATES

- Nylon lube plate protects fifth wheel plate from the wear of normal towing
- Eliminates the need for messy grease
- Large surface for extra protection

Part Number	Description	Packaging	Master Carton
83001	Lube Plate for use with Elite and REESE 20K Fifth Wheel Hitches Only, 12"	Display Bag	1
83002	Lube Plate for use with REESE 16K and 22K Fifth Wheel Hitches, 10"	Display Bag	1
83003	Lube Plate for use with Titan 16K Fifth Wheel Hitches,	Poly Bag	1
83004	Lube Plate for use with Titan 16K Fifth Wheel Hitches, 12", 1/8" Thick	Poly Bag	1
6011	Lube Plate for use with Select Series 16K and 22K and REESE Fifth Wheel Hitches, 10"	Display Bag	1



FIFTH WHEEL ACCESSORY KIT

- Everything a new fifth wheel buyer needs to get started
- Grease, lube, plate, cover, king pin lock and lock links

Part Number	Description	Packaging	Master Carton
30053	Fifth Wheel Starter Kit, for REESE Only	Boxed	1
30055	Fifth Wheel Cover Only	Boxed	1



CHAIN BRACKET KIT

- Fits REESE® industry standard fifth wheel rails and most popular brands
- Provides secure attachment for trailer safety chains

Part Number	Description	Packaging	Master Carton
50223	Chain Bracket Kit, 18,000 lbs. Each	Boxed	1



FIFTH WHEEL LOCKS

- Includes 2 keys

Part Number	Description	Packaging	Master Carton
63251	King Pin Lock, Extruded T6 Tempered Aluminum Body	Plastic Shroud	1
63254	Base Rails Lock, 1/2"	Plastic Shroud	1

CUSTOM FIFTH WHEEL MOUNTING RAILS



Rails - 58058

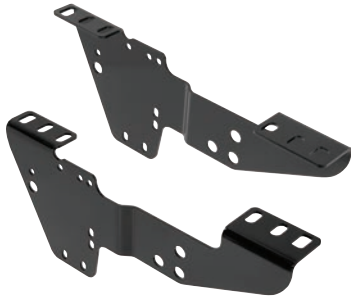

Custom Brackets - 50064

CUSTOM INDUSTRY STANDARD MOUNTING RAILS

- Mounting rails for full-size trucks
- Quick and easy installation with full truck bed access
- For use on all fifth wheel hitches except Elite™ Series



Part Number	Description	Packaging	Master Carton
58058	Mounting Rails, 10-Bolt Design	Boxed	1
Replacement Parts			
58314	Mounting Rail Brackets	Boxed	1
58503	Mounting Rail Corrugation Spacer Kit, 10-Bolt Design	Poly Bag	1
58467	Mounting Rail Pins and Clips, Includes: (4) Hole Style Pins and (4) Clips	Poly Bag	1
58430	Mounting Rail Installation Hardware, Includes: (10) Carriage Bolts 1/2" - 13 x 2" Grade 5, (10) Hex Nuts 1/2" - 13 Grade 5, (10) Plated Lock-washers 1/2", (10) Conical Washers 1/2" and (10) Blocks 5/16" x 1" x 2"	Poly Bag	1

CUSTOM INSTALL BRACKET APPLICATION GUIDE

Make/Model	Style	Years	Bracket	Rail	10 Bolt Kit	No Drill	Footnote
CHEVROLET/GMC							
Silverado/Sierra 1500	LD (Old Body Style) Does Not Fit MagneRide Magnetic Ride Suspension	99-19	50064	58058	50064-58	Ø	SW
Silverado/Sierra 1500 HD	(Classic)	01-07	50064	58058	50064-58	Ø	
Silverado/Sierra 2500		99-04	50064	58058	50064-58	Ø	
Silverado/Sierra 2500 HD		01-10	50064	58058	50064-58	Ø	
Silverado/Sierra 2500 HD	Except with OEM HD Towing Prep Package	11-19	50066	58058	50066-58	Ø	
Silverado/Sierra 3500	(Classic)	01-07	50064	58058	50064-58	Ø	
Silverado/Sierra 3500 HD		07-10	50064	58058	50064-58	Ø	
Silverado/Sierra 3500 HD	Except with OEM HD Towing Prep Package	11-19	50066	58058	50066-58	Ø	
DODGE/RAM							
Ram 1500	Except Mega Cab	02-08	50040	58058	50040-58	Ø	
Ram 1500	Mega Cab	06-08	50140	58058	50140-58	Ø	
Ram 1500	(Classic)	09-20	50142	58058	50142-58	Ø	SW
Ram 1500	Except w/Air Suspension or 5.7 ft. Bed (Classic)	14-20	50141	58058	50141-58	Ø	MB
Ram 2500		03-09	50140	58058	50140-58	Ø	
Ram 2500	Except Mega Cab & w/Overload Springs	03-12	50040	58058	50040-58		
Ram 2500	Except w/Gas Engines w/Overload Springs	10-10	50140	58058	50140-58	Ø	
Ram 2500	Except w/Gas Engines w/Overload Springs	10-12	50140	58058	50140-58		
Ram 2500		14-19	50054	58058	50054-58	Ø	
Ram 3500		03-09	50140	58058	50140-58	Ø	
Ram 3500	Except Mega Cab & w/Overload Springs	03-12	50040	58058	50040-58		
Ram 3500	Except w/Gas Engines w/Overload Springs	10-12	50140	58058	50140-58		
Ram 3500		13-19	50085	58058	50085-58	Ø	
Ram 3500		00-14	50085	58058	50085-58	Ø	
FORD							
F-150		04-14	50081	58058	50081-58	Ø	SW
F-150	Except Raptor	15-20	50087	58058	50087-58	Ø	SW
F-150 Heritage	Styleside	97-04	50042	58058	50042-58	Ø	
F-250	Styleside	97-99	50042	58058	50042-58	Ø	
F-250/350 Super Duty	Except Cab & Chassis	99-04	50043	58058	50043-58		
F-250/350 Super Duty	Except Cab & Chassis	99-10	50082	58058	50082-58	Ø	
F-250/350 Super Duty	Except Cab & Chassis	11-16	50026	58058	50026-58	Ø	
F-250/350 Super Duty	Except Dual Rear Wheel or Cab & Chassis	17-20	50074	58058	50074-58		
F-450 Super Duty	Except Cab & Chassis	08-10	50082	58058	50082-58	Ø	
F-450 Super Duty	Except Cab & Chassis	11-16	50026	58058	50026-58	Ø	
TOYOTA							
Tundra		07-20	50084	58058	50084-58	Ø	SW

MB = Will not fit models equipped with air suspension package

SW = Do not install on a truck with less than a 6' long bed unless the trailer is equipped with a Sidewinder pin box coupler #SW16K or #SW19K

OUTBOARD INDUSTRY STANDARD MOUNTING RAILS

- Rails are wider (48 in.) for faster install, because the mounting points are outside the truck frame, allowing the installer to avoid under-bed components
- Grade 8 hardware, meets all Canadian requirements
- SAE J2638 Compliant



Rails - 30153



Brackets - 56010

Part Number	Description	Packaging	Master Carton
30153	Outboard Mounting Rails, 10-Bolt Design	Boxed	1
Replacement Parts			
58467	Outboard Mounting Rail Pins and Clips, Includes: (4) Hole Style Pins and (4) Clips	Poly Bag	1
58503	Outboard Mounting Rail Corrugation Spacer Kit, 10-Bolt Design	Poly Bag	1
58504	Outboard Mounting Rail Installation Hardware, Includes: (10) Carriage Bolts 1/2" - 13 x 2", Grade 8, (10) Hex Nuts 1/2" - 13 Grade 5 and (10) Blocks 5/16" x 1" x 2", 10-Bolt Design	Poly Bag	1

NOTE: Based on heavy duty, accelerated life cycle criteria developed by SAE for fifth wheels. SAE J2638 is a fatigue and static requirements of new European style test of 900,000 cycles

OUTBOARD CUSTOM INSTALL BRACKET APPLICATION GUIDE

Make/Model	Style	Years	Bracket	Rail	10 Bolt Kit	No Drill	Footnote
CHEVROLET/GMC							
Silverado/Sierra 1500	LD (Old Body Style) Does Not Fit MagneRide Magnetic Ride Suspension	99-19	56007	30153	56007-53	Ø	SW
Silverado/Sierra 1500	New Body Style	99-20	56015	30153	56007-53	Ø	SW
Silverado/Sierra 1500 HD	(Classic)	01-07	56007	30153	56007-53	Ø	
Silverado/Sierra 2500		99-04	56007	30153	56007-53	Ø	
Silverado/Sierra 2500 HD		01-10	56007	30153	56007-53	Ø	
Silverado/Sierra 2500 HD	6.6 ft. Bed	08-10	56014	30153	56004-53	Ø	
Silverado/Sierra 2500 HD	Except with OEM HD Towing Prep Package	11-19	56001	30153	56001-53	Ø	
Silverado/Sierra 3500	(Classic)	01-07	56007	30153	56007-53	Ø	
Silverado/Sierra 3500 HD		07-10	56007	30153	56007-53	Ø	
Silverado/Sierra 3500 HD	6.6 ft. Bed	08-10	56014	30153	56004-53	Ø	
Silverado/Sierra 3500 HD	Except with OEM HD Towing Prep Package	11-19	56001	30153	56001-53	Ø	
DODGE/RAM							
Ram 1500		19-20	56018	30153	56018-53	Ø	
Ram 2500		03-13	56011	30153	56011-53	Ø	
Ram 2500		14-20	56009	30153	56009-53	Ø	
Ram 3500		03-12	56011	30153	56011-53	Ø	
Ram 3500	Except w/RamBox Cargo Management System or Models w/Air Suspension	13-18	56010	30153	56010-53	Ø	
Ram 3500	Except w/RamBox Cargo Management System or Models w/Air Suspension	19-20	56021	30135	56021-53	Ø	
FORD							
F-150		04-14	56006	30153	56006-53	Ø	SW
F-150	Except Raptor	15-20	56034	30153	56034-53	Ø	SW
F-250/350 Super Duty	Except Cab & Chassis	99-10	56005	30153	56005-53	Ø	
F-250/350 Super Duty	Except Cab & Chassis	11-16	56016	30153	56016-53	Ø	
F-250/350 Super Duty	Except Cab & Chassis	17-20	56017	30153	56017-53	Ø	
F-450 Super Duty	Except Cab & Chassis	08-10	56005	30153	56005-53	Ø	
F-450 Super Duty	Except Cab & Chassis	11-16	56016	30153	56016-53	Ø	
F-450 Super Duty	Except Cab & Chassis	17-20	56017	30153	56017-53	Ø	

SW = Do not install on a truck with less than a 6' long bed unless the trailer is equipped with a Sidewinder pin box coupler #SW16K or #SW19K

**UNIVERSAL INDUSTRY STANDARD
RAIL INSTALLATION KITS**



- Installation kits for full-size trucks
- Quick and easy installation with full truck bed access
- For use on all fifth wheel hitches except Elite™ Series
- May require additional kit - see application guide



Rails and Installation Kit - 30035

Part Number	Description	Packaging	Master Carton
30035	Fifth Wheel Rails and Installation Kit, Includes Brackets and Hardware, 10-Bolt Design	Boxed	1
30035-040	Fifth Wheel Rails and Installation Kit, Includes Brackets and Hardware, 10-Bolt Design	Boxed (40 Pack)	1

UNIVERSAL INDUSTRY STANDARD RAIL KIT APPLICATION GUIDE

Make/Model	Style	Years	Rail	Required Adapter	Footnote
CHEVROLET/GMC					
C/K Series		73-00	30035		
Silverado/Sierra 1500	(Classic)	99-07	30035		
Silverado/Sierra 1500	LD (Old Body Style) Except High Desert Package	07-19	30035		
Silverado/Sierra 1500 HD	(Classic)	01-07	30035		
Silverado/Sierra 2500		99-04	30035		
Silverado/Sierra 2500 HD	Except with OEM HD Towing Prep Package	01-19	30035		
Silverado/Sierra 3500	(Classic)	01-07	30035		
Silverado/Sierra 3500 HD	Except with OEM HD Towing Prep Package	07-19	30035		
DODGE/RAM					
D Series		73-93	30035		
Dakota		94-04	30035		
Ram 1500		94-01	30035		
Ram 1500		02-08	30035	58023	
Ram 1500		09-12	30035	58386	SW
Ram 1500	Except w/Air Suspension or w/ECODiesel Engine (Classic)	13-20	30035	58386	MB, SW
Ram 1500	Except w/Air Suspension (Classic)	14-20	30035	58523	MB, SW
Ram 2500		94-02	30035		
Ram 2500	Except w/Overload Springs	03-13	30035	58023	
Ram 2500	w/Overload Springs	03-12	30035	58186	
Ram 2500		14-20	30035	58522	
Ram 3500		94-02	30035		
Ram 3500	Except w/Overload Springs	03-12	30035	58023	
Ram 3500	w/Overload Springs	03-12	30035	58186	
Ram 3500		13-20	30035	58520	
FORD					
F-100		75-83	30035		
F-150		75-96	30035		
F-150	Styleside, Except SuperCrew	97-03	30035		
F-150		04-14	30035	58426	
F-150	Except Raptor	15-20	30035	58531	
F-150 Heritage	Styleside	04-04	30035		
F-250/350		75-96	30035		
F-250/350	Heavy Duty	77-97	30035		
F-250/350	Styleside	97-99	30035		
F-250/350 Super Duty	Except Cab & Chassis	99-16	30035		
F-450 Super Duty	Except Cab & Chassis	08-16	30035		
NISSAN					
Titan		04-15	30035	58405	SW
TOYOTA					
Tundra	Regular Cab 8 ft. Bed	00-06	30035	58197	
Tundra		07-19	30035		SW

MB = Will not fit models equipped with air suspension package

SW = Do not install on a truck with less than a 6' long bed unless the trailer is equipped with a Sidewinder pin box coupler #SW16K or #SW19K

FIFTH WHEEL HITCH VERTICAL ADJUSTMENT

Part Number	Description	Minimum (in.)	Maximum (in.)
30047	16K	13-1/2	17
30093	16K	12-1/2	16-1/2
30075	16K with Round Tube Slider	15-1/2	17-3/4
30051	16K with Square Tube Slider	14 3/4	17
30094	16K with Square Tube Slider	14	16-3/4
30142	18K Elite	14-1/2	18-1/4
30144	18K Elite with Slider	16-1/2	19
30890	20K M5	14	18
30081	20K	13-1/4	17
30119	20K	13-1/2	17

Part Number	Description	Minimum (in.)	Maximum (in.)
30083	20K with Round Tube Slider	15-1/4	17 3/4
30084	20K with Square Tube Slider	14-3/4	17-1/4
30121	20K with Square Tube Slider	14-3/4	17-1/4
30160	20K Ram Drop In	14-1/4	18
30033	22K	13	17
30862	25K	13-1/4	16-3/4
30143	25K Elite	14-1/2	17
30871	26.5K Elite	15	17-1/2
30054	30K Low Profile	9-1/2	12-1/2

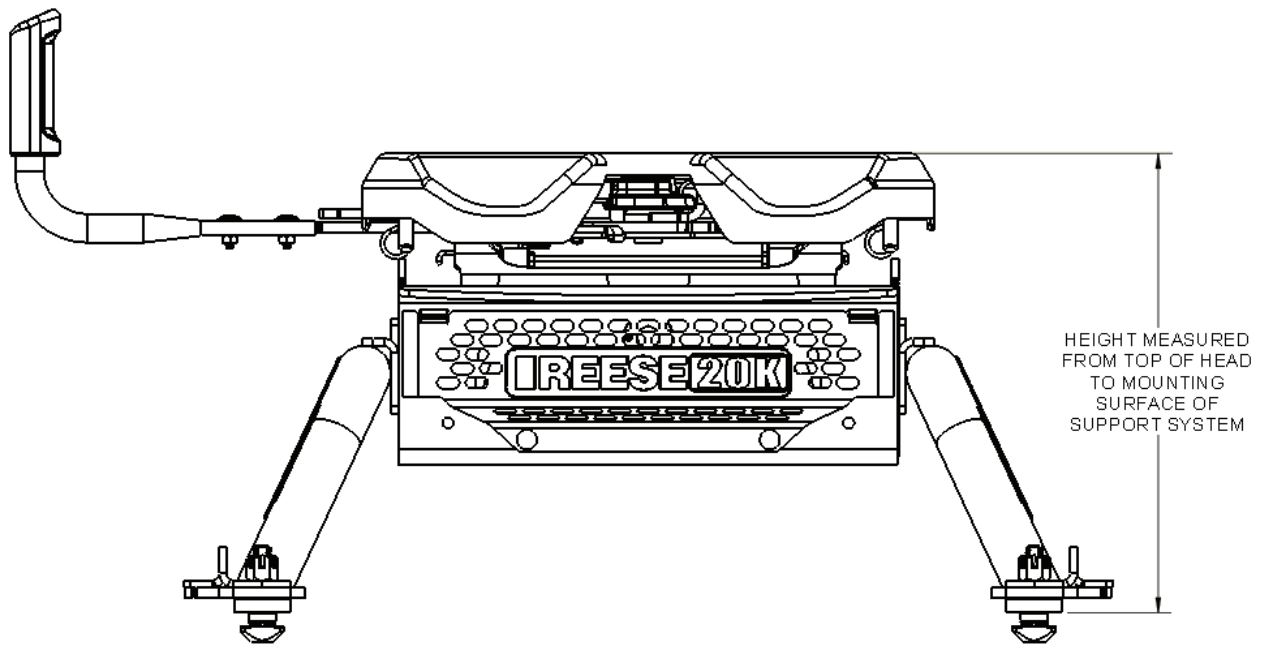

FIFTH WHEEL MOUNTING RAIL HEIGHT

Part Number	Description	Height (in.)
58058	10-Bolt Inboard Rail	1
30153	10-Bolt Outboard Rail	1-3/4
30126	Elite Rail Kit, Ford	0
30868	Elite Rail Kit, GM	0
30852	Elite Rail Kit, Dodge	0

FIFTH WHEEL RAIL KIT ADAPTER HEIGHT

Part Number	Description	Height (in.)
30156	Ford OE / Elite Rail Kit Adapter	3-1/4
30154	RAM OE Rail Kit Adapter	2-3/4

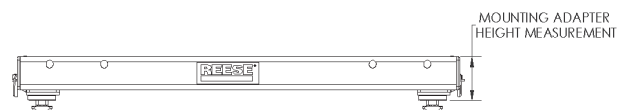
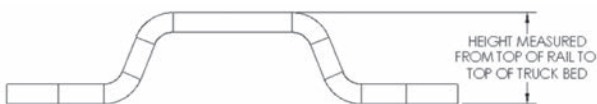

REPLACEMENT PARTS

ELITE™ SERIES 18K FIFTH WHEEL HITCH

• Part Number: 30142†

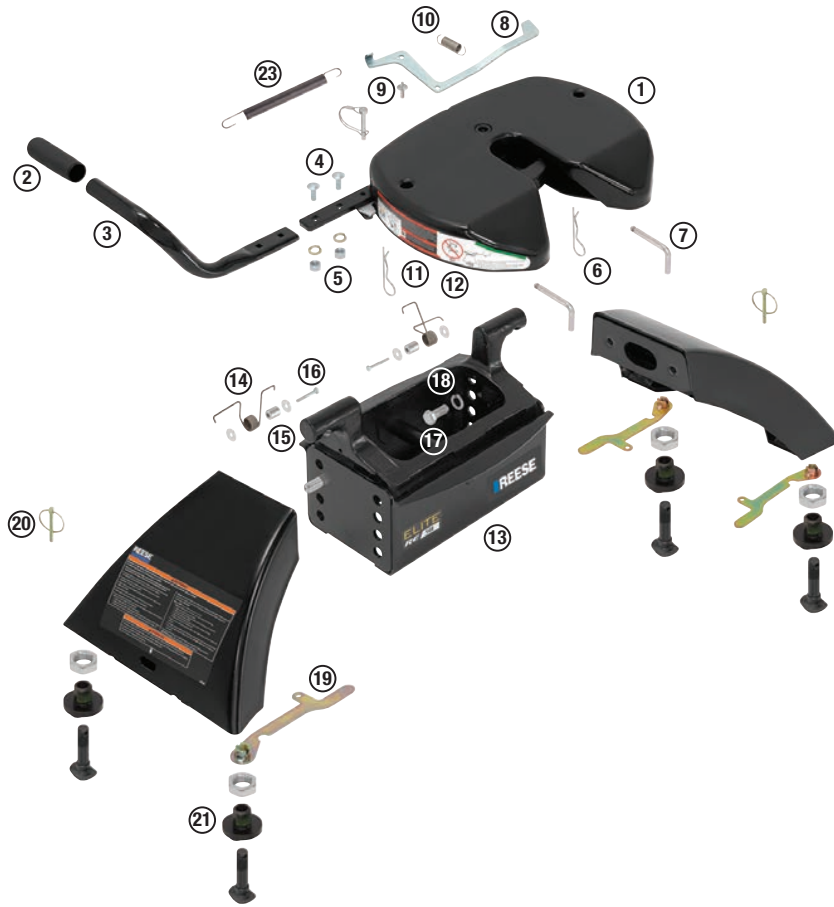

† = Available While Supplies Last

Part Number	Ref.	Qty.	Description
117300			18K Head Kit
	1	1	18K Head
	2	2	Grip, Vinyl
	3	1	Handle Tube
	4	2	3/8 Carriage Bolt
	5	2	Nut, 3/8
	8	1	Indicator Flag
	9	1	Drive Rivet
	10	1	Spring, 1.75"
	11	1	Label, Op. Warning
	12	1	Label, Pinch Pt.
58215			Handle Kit
	2	1	Grip, Vinyl
	3	1	Handle Tube
	4	2	Carriage Bolt, 3/8
	5	2	Nut, 3/8
58240			Pull Pin Kit, (90 Degree)
	6	2	Clip
	7	2	Pull Pin, (90 Degree)

Part Number	Ref.	Qty.	Description
58216			Indicator Flag Kit
	8	1	Indicator Flag
	9	1	Drive Rivet
	10	1	Spring, 1.75"
58225	13	1	18K Center Section with Bumpers
58229			Head Pivot Springs
	14	2	Torsion Spring
	15	2	Tube Spacer
	16	2	Thumb Screw
111428	20	1	Lynch Pins
58419	21	4	Foot Assembly Kit Foot Assembly, A&B
58230	23	1	Jaw Spring
58255†	17	1	Pointed Bolt Kit
58276	19	1	Wrench
58514	18	1	Center Section Shim Kit

ELITE™ SERIES 26.5K FIFTH WHEEL HITCH

• Part Number: 30871†

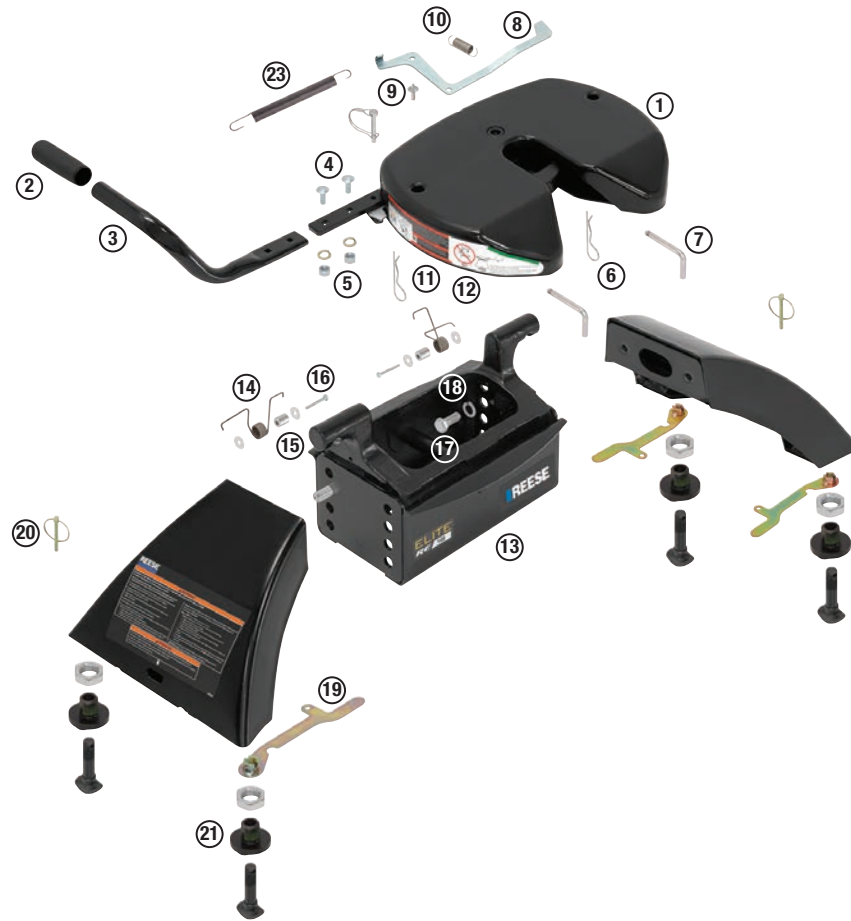

† = Available While Supplies Last

Part Number	Ref.	Qty.	Description
117300			18K Head Kit
	1	1	18K Head
	2	2	Grip, Vinyl
	3	1	Handle Tube
	4	2	3/8 Carriage Bolt
	5	2	Nut, 3/8
	8	1	Indicator Flag
	9	1	Drive Rivet
	10	1	Spring, 1.75"
	11	1	Label, Op. Warning
	12	1	Label, Pinch Pt.
	58215		
2		1	Grip, Vinyl
3		1	Handle Tube
4		2	Carriage Bolt, 3/8
5		2	Nut, 3/8
58240			Pull Pin Kit, (90 Degree)
	6	2	Clip
	7	2	Pull Pin, (90 Degree)

Part Number	Ref.	Qty.	Description
58216			Indicator Flag Kit
		1	Indicator Flag
		1	Drive Rivet
		1	Spring, 1.75"
58541	13	1	26.5K Center Section with Bumpers
58229			Head Pivot Springs
	14	2	Torsion Spring
	15	2	Tube Spacer
	16	2	Thumb Screw
111428	20	1	Lynch Pins
58419			Foot Assembly Kit
			Foot Assembly, A&B
58230	23	1	Jaw Spring
58542	17	1	Pointed Bolt Kit
58276	19	1	Wrench
58514	18	1	Center Section Shim Kit
58543	24	2	26.5K Wheel Base Arch

REPLACEMENT PARTS

20K FIFTH WHEEL HITCH

• Part Number: 30081†

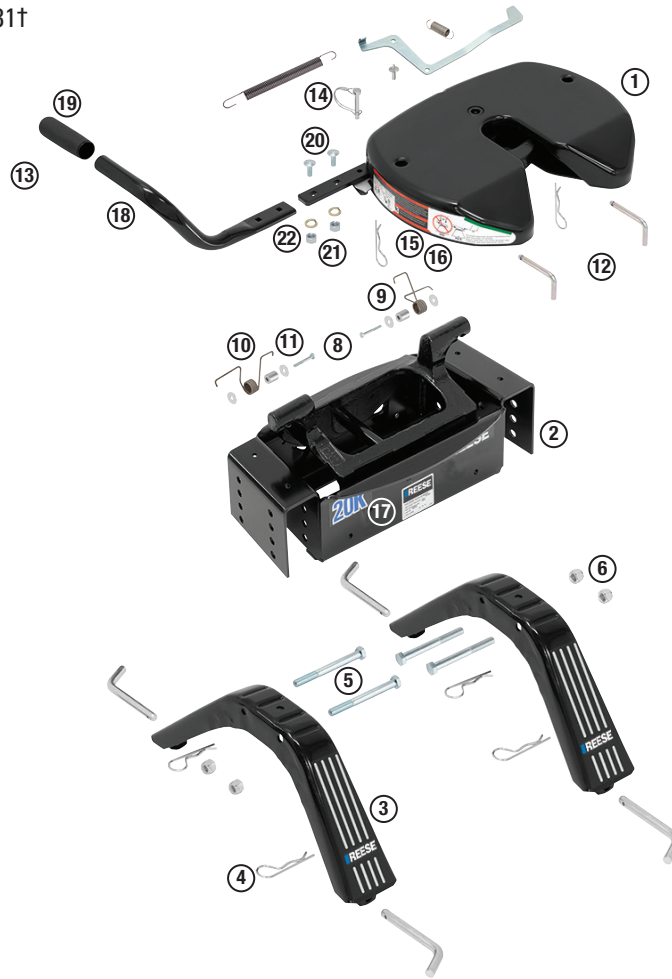

† = Available While Supplies Last

Part Number	Ref.	Qty.	Description
30727			Service Kit Arches (2x Legs)
	3	2	Arches
58215			Handle Kit
	18	1	Handle Tube
	19	1	Handle Grip
	20	2	Carriage Bolt 3/8"
	21	2	Nut 3/8"
	22	2	Lockwasher 3/8"
58216			Indicator Flag Kit
58229			Head Pivot Springs
	8	2	1/4" - 20 x 1.5 Hex Head Bolt
	9	2	Tube Spacer
	10		LH and RH Torsion Spring
	11	4	1/4" Washer
58230			Jaw Springs
58240			Pull Pin Kit (90 Degree)
			Head -Pull Pin Service Kit
	4	2	Clip
	12	2	Pull Pin (90 Degree)

Part Number	Ref.	Qty.	Description
58293			20K Service Kit Center Section
	2		Weldment, 20K Center
	17	2	Label, 20K 5th Wheel
58296			Center Section Bolt Kit
	5	4	1/2-13 x 4.5 Grade 5 Bolt
	6	4	1/2-13 Lock Nut
117300			20K Head Service Kit
	1		20K Head Assembly
	13		Hang Tag
	14		Bail Pin with Lanyard
	15		Warning Label
	16		Head Warning Label
	18		Handle Tube
	19		Handle Grip
	20		Carriage Bolts
	21	2	3/8 Nut
	22	2	3/8 Lock Washer

16K FIFTH WHEEL HITCH

• Part Number: 30047

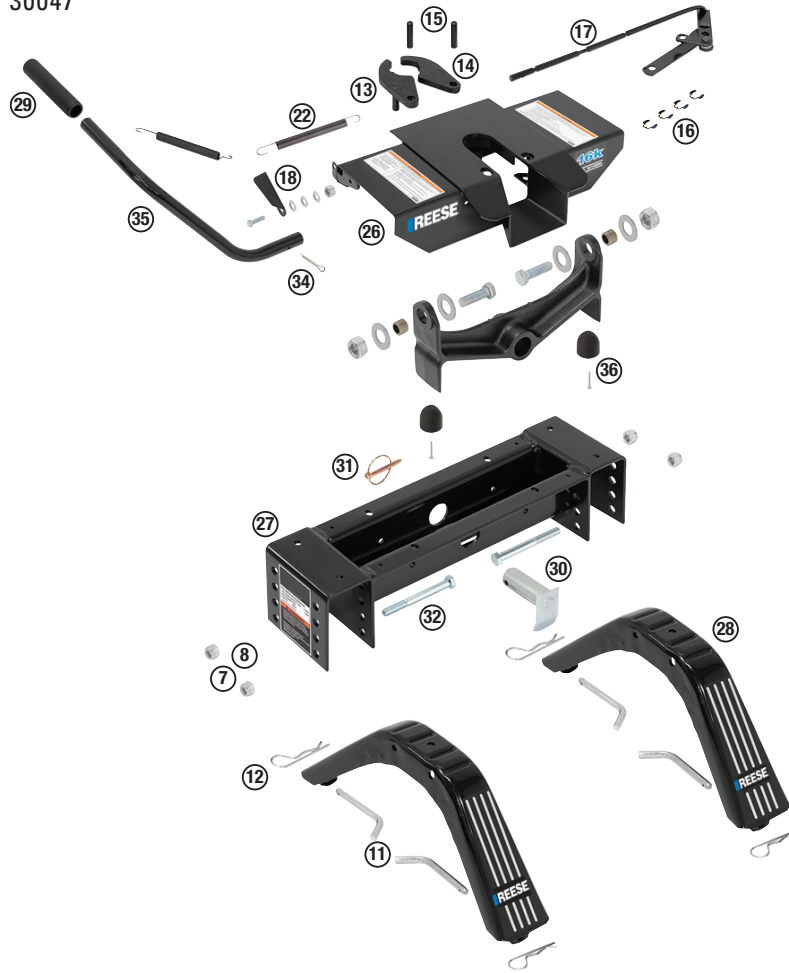

Part Number	Ref.	Qty.	Description
58146	26	1	16K Head Assembly
58147	27	1	16K Head Support
58053			Pull Pin Kit
	11	4	Pull Pins
	12	4	Spring Cotter Pins
58056			Jaw Kit
	13	1	Jaw LH (Weldment)
	14	1	Jaw RH (Weldment)
	15	2	Jaw Pivot Pins
	16	4	Klip Rings
58055			Handle Kit
	29	1	Cushion Grip
	34	1	Cotter Pin
	35	1	Handle Tube
58094	29	1	Cushion Grip
30579	17	1	Actuating Rod
58054			Klip Ring Kit
	16	10	Klip Rings

Part Number	Ref.	Qty.	Description
30776			Spring Kit
	22	1	Spring
58521			16K Head Assembly Hardware
	4		1/2" Nut
	34	1	Cotter Pin
	32	4	Hex Bolts, 1/2"-13 x4.5" HNCS
	2		Rubber Bumpers
	2		8-32 Nuts
	22	4	Spring Clips
	2		Machine Screws, 8-32 x 1
	4		Pull Pins
58484	30	1	Pivot Pin
55478	31	1	Klik Pin
30416	18	1	Locking Latch
30727	28	2	Legs Only
58089	36		Bumper Kit
	2		8-32x1 Screws
	2		8-32 Nuts
	2		Bumpers

REPLACEMENT PARTS

22K FIFTH WHEEL HITCH

• Part Number: 30033†

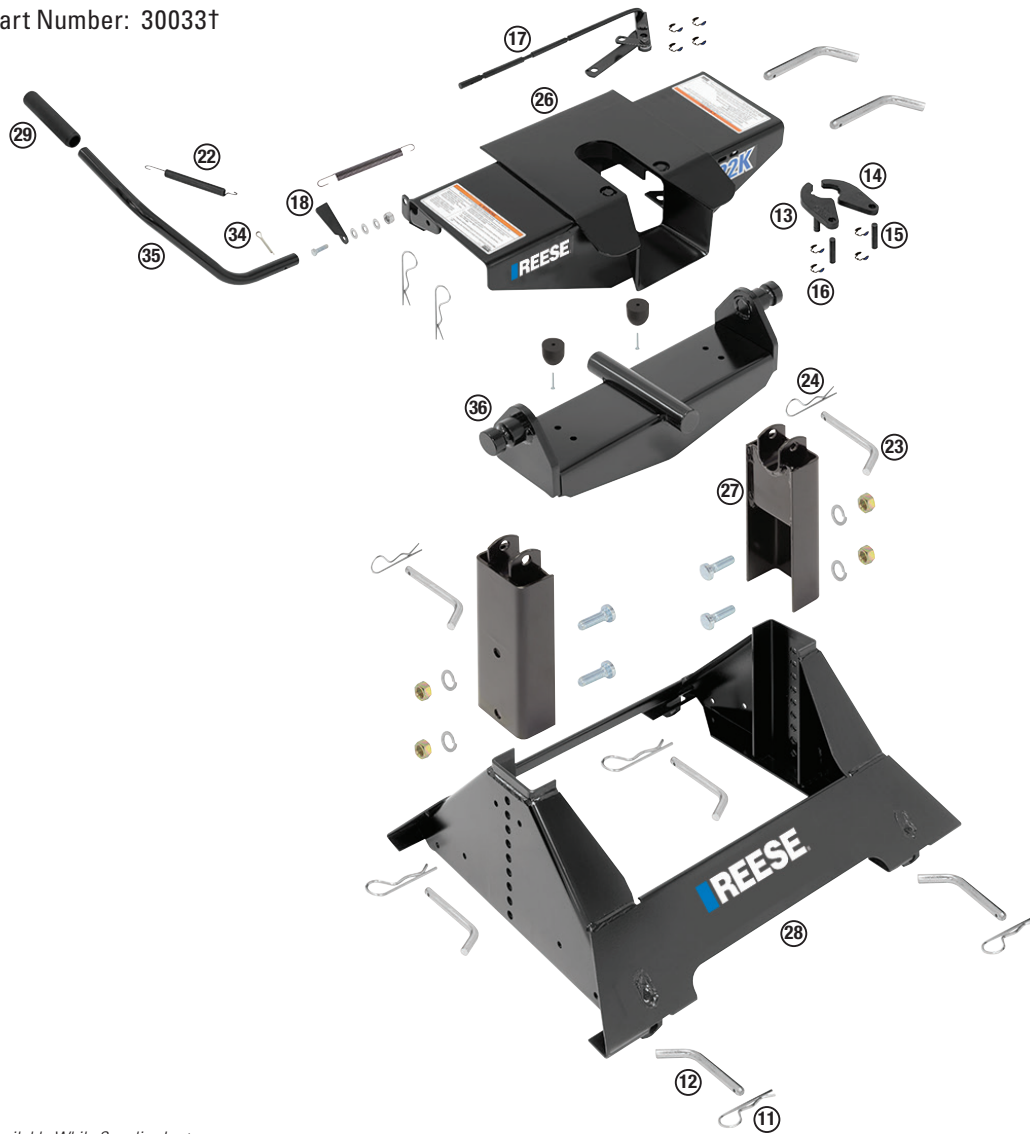

† = Available While Supplies Last

Part Number	Ref.	Qty.	Description
6020			Pull Pin Kit
	23	1	Pull Pin
	24	1	Spring Clip
30416	18	1	Locking Latch
30579	17	1	Actuating Rod
30730			Base with Adjustment Brackets
	27	2	Adjustment Brackets
	28	1	Base Assembly
30776			Spring Kit
	22	1	Spring
58053			Pull Pin Kit
	12	4	Pull Pins
	11	4	Spring Cotter Pins
58054	16		Klip Ring Kit
	10		Klip Rings

Part Number	Ref.	Qty.	Description
58055			Handle Kit
	29	1	Cushion Grip
	34	1	Cotter Pin
	35	1	Handle Tube
58056			Jaw Kit
	13	1	Jaw LH (Weldment)
	14	1	Jaw RH (Weldment)
	15	2	Jaw Pivot Pins
	16	4	Klip Rings
58094	29	1	Cushion Grip
58099	26	1	22K Head
	36	1	Pivot Beam

FIFTH WHEEL RAILS

• Part Number: 30035

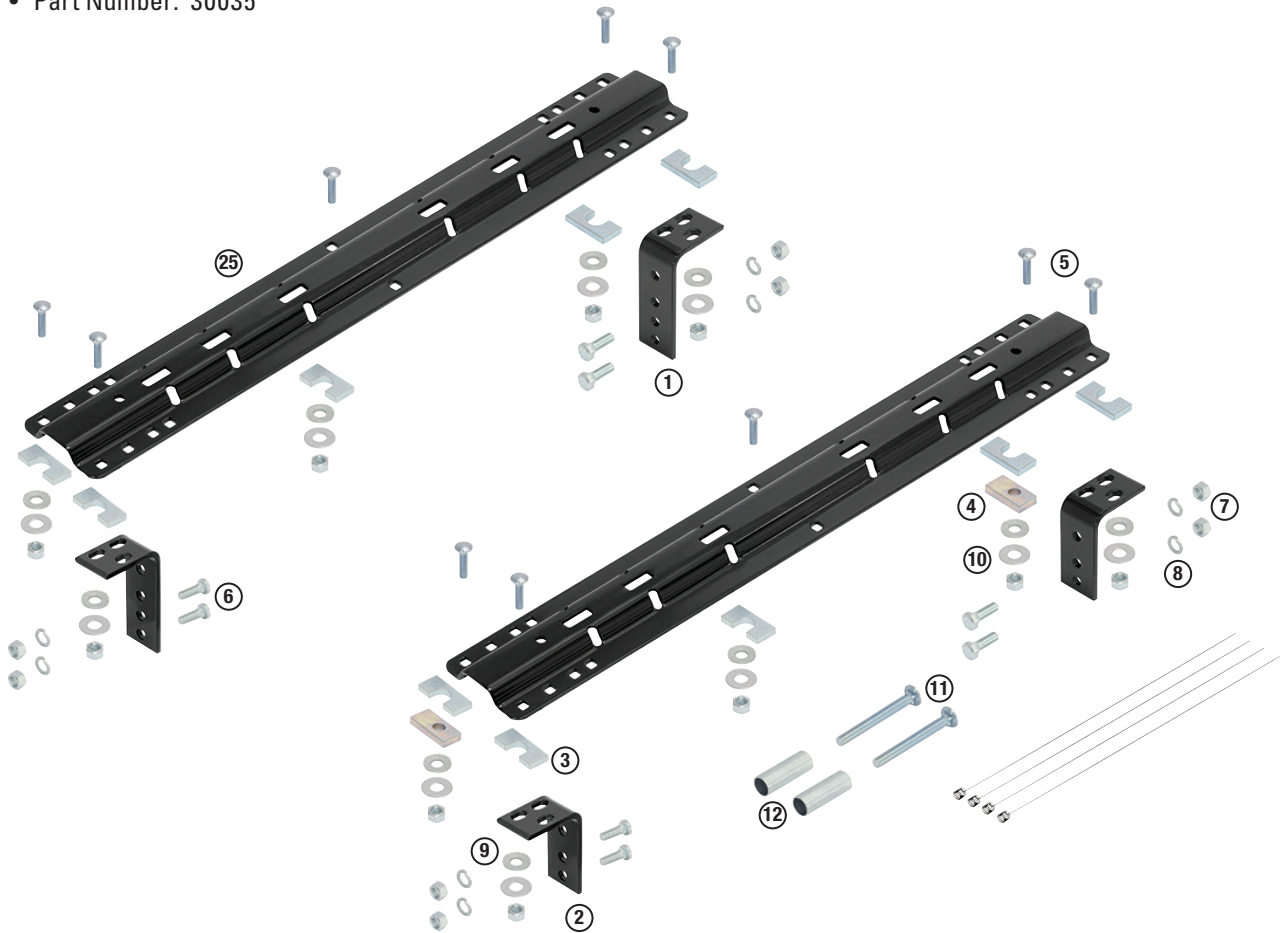

Part Number	Ref.	Qty.	Description
30439			Mounting Kit – Less Rails
	1	2	Brackets – Long
	2	2	Brackets – Short
	3	10	Spacer
	4	2	Spacers
	5	10	Carriage Bolts (1/2"-13 x 2")
	6	8	Knurl Bolts (1/2"-13 x 1-1/2")
	7	18	Hex Nut Heads (1/2"-13)
	8	18	Lock Washers (1/2")
	9	6	Conical Washers (1/2")
	10	4	Flat Washers (1/2")
	11	2	Carriage Bolts (1/2"-13 x 4")
	12	2	Bushings

Part Number	Ref.	Qty.	Description
58058	25		Base Rail Kit – Less Mounting Kit
		2	Base Rails
58166			Dodge Hardware Upgrade Kit (2002 Half-Ton Only)
	11	2	Carriage Bolts (1/2"-13 x 4")
	12	2	Bushings
58164		1	Rail Kit Hardware (Minus Mounting Brackets)
58314		1	Mounting Brackets (Minus Hardware)
55055	6	1	Knurl Bolt (1/2"-13 x 1-1/2")



30093†

16K FIFTH WHEEL HITCH

LAST CHANCE

Part Number	Description	Capacity (lbs.)	Substitute Part Number	Packaging	Master Carton
30099†	16K Fifth Wheel Head and Support	16,000	30047	Boxed	1
30093†	16K Fifth Wheel	16,000	30047	Boxed	1
30128†	16K Fifth Wheel Head, Support, Legs and Rails	16,000	30047	Boxed	1



30094†

16K FIFTH WHEEL HITCH WITH SQUARE TUBE SLIDER

LAST CHANCE

Part Number	Description	Capacity (lbs.)	Substitute Part Number	Packaging	Master Carton
30094†	16K Fifth Wheel Head, Support and Slider	16,000	30051	Boxed	1
30129†	16K Fifth Wheel Head, Support, Slider and Rails	16,000	30051	Boxed	1



30143†

ELITE™ SERIES FIFTH WHEEL HITCHES

LAST CHANCE

Part Number	Description	Capacity (lbs.)	Substitute Part Number	Packaging	Master Carton
30142†	18K Elite Series Fifth Wheel, Pre-Assembled	18,000	30928	Boxed	1
30144†	18K Elite Series Fifth Wheel with Slider, Pre-Assembled	18,000	30928	Boxed	1
30143†	25K Elite Series Fifth Wheel, Pre-Assembled	25,000	30929	Boxed	1
30871†	26.5K Elite Series Fifth Wheel, Pre-Assembled	26,500	30929	Boxed	1



30081†

20K FIFTH WHEEL HITCH WITH ELITE™ SERIES HEAD

LAST CHANCE

Part Number	Description	Capacity (lbs.)	Substitute Part Number	Packaging	Master Carton
30081†	20K Fifth Wheel	20,000	30928	Boxed	1
30083†	20K Fifth Wheel with Round Tube Slider	20,000	30928	Boxed	1
30084†	20K Fifth Wheel with Square Tube Slider	20,000	30928	Boxed	1



30121†

20K FIFTH WHEEL HITCH WITH SQUARE TUBE SLIDER

LAST CHANCE

Part Number	Description	Capacity (lbs.)	Substitute Part Number	Packaging	Master Carton
30121†	20K Fifth Wheel Head, Support and Slider	20,000	30928	Boxed	1
30133†	20K Fifth Wheel Head, Support, Slider and Rails	20,000	30928	Boxed	1



30033†

22K FIFTH WHEEL HITCH

LAST CHANCE

Part Number	Description	Capacity (lbs.)	Substitute Part Number	Packaging	Master Carton
30033†	22K Fifth Wheel	22,000	30929	Boxed	1



30862†

25K FIFTH WHEEL HITCH

LAST CHANCE

Part Number	Description	Capacity (lbs.)	Substitute Part Number	Packaging	Master Carton
30862†	25K Fifth Wheel	25,000	30929	Boxed	1



30092†

SQUARE TUBE SLIDER

LAST CHANCE

Part Number	Description	Capacity (lbs.)	Substitute Part Number	Packaging	Master Carton
30092†	Square Tube Slider	20,000	30048	Boxed	1

† = Available while supplies last



GOOSENECK HITCHES

Draw-Tite® gooseneck hitches are offered in a few types of configurations. They are designed to be mounted above or below the pickup bed. Either design (above or below) allows for minimal obstruction when the ball is not in the towing position. This permits full use of the pick-up bed.

GOOSENECK COUPLER FOR RVs

16K Goose Box	G-2
20K Goose Box	G-2
Goose Box Accessories	G-2

ELITE™ SERIES GOOSENECK HITCH SYSTEMS

Complete Under-Bed System	G-3
Complete Under-Bed System Application Guide	G-3
Pop-In™ Ball Kit	G-4

DRAW-TITE® GOOSENECK HITCH SYSTEMS

Hide-A-Goose™	G-5
Fold-Down	G-6
Remov-A-Ball®	G-6
Draw-Tite® Gooseneck Application Guide	G-7
Installation Tools	G-7

ABOVE-BED GOOSENECK HITCH SYSTEMS

Hi-Rise™ Conversion Hitch	G-4
Elite™ Series	G-8
The Goose™	G-8
Standard Series	G-8

ACCESSORIES

Safety Chains	G-9
Hitch Balls	G-9
Replacement Parts	G-9

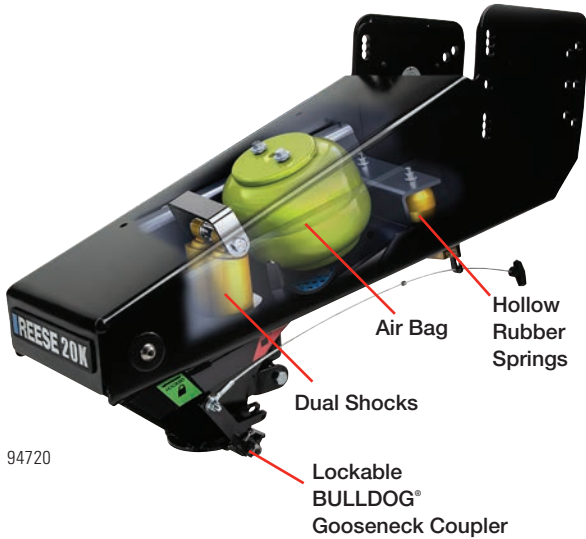

94720

20K



94716

16K

GOOSE BOX™ GOOSENECK COUPLER FOR RVs

Take the heavy equipment out of the truck bed!
The Goose Box™ gooseneck coupler is specifically designed for RV trailer owners who wish to tow with their gooseneck hitch.

- Replaces a traditional pin box so the RV works with a gooseneck hitch
- Step up to RV comfort and keep your gooseneck hitch
- Endorsed by Lippert Components, Inc. for their frame systems
- 5th Airborne™ technology for superior ride performance
- Lockable BULLDOG® gooseneck coupler
- Improved air bag, dual shocks and hollow rubber springs provide multi-directional shock absorption
- Increased height adjustment capability for today's taller truck beds
- Easy reach lanyard
- Onboard safety chain storage
- Air pressure relief valve prevents overfilling
- Rated for 16K and 20K lbs. capacity utilizing both CSA and SAE J2638 test standards
- Patented and patents pending
- Fits wing set make and model #'s:
 - Lippert #1621 - Lippert #1621 HD - Lippert #0719
 - Fabex PB-600 Series
- Spacer kit required for installation on:
 - Lippert #1716 - Lippert #1116 - Lippert #0115



Part Number	Description	Capacity (lbs.)	Packaging	Master Carton
94716	Goose Box For Lippert #1621 and #1716 Wing Sets	16,000	Boxed	1
94720	Goose Box For Lippert #1621 and #1716 Wing Sets	20,000	Boxed	1
Accessory Parts				
49150	Safety Chain Kit, Contains: (2) Grade 70, 5/16" x 44" with 5/16" Clevis Hook and Mounting Hardware	16,000	Barrel	1
49151	Safety Chain Kit, Contains: (2) Grade 70, 5/16" x 44" with 5/16" Clevis Hook and Mounting Hardware	20,000	Barrel	1
61301	Spacer Kit		Boxed	1
Replacement Part				
86007	Air System Service Kit		Boxed	1



Automatically locks when coupling



Lockable BULLDOG® coupler for added security



Increased height adjustment for taller truck beds

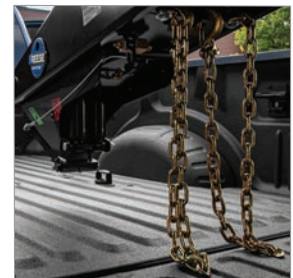

Safety chains with clevis hook and storage on unit

25K

ELITE™ SERIES UNDER-BED GOOSENECK HITCH



- Easy Under-Bed bolt-in installation
- Rated for 25,000 lbs. gross weight capacity*
- Passes SAE J2638, the toughest industry standard
- Pop-In™ Ball lever inside ball head activates ball bearing locking system, lift and turn lever to unlock and remove ball
- Fifth wheel ready using outer four holes to mount a fifth wheel hitch
- Two safety chain holders attach directly to rail system
- Hole cover keeps Pop-In™ Ball sleeve free of debris
- Includes storage bag
- Patented and Patents pending



30138-26 - Ford Application

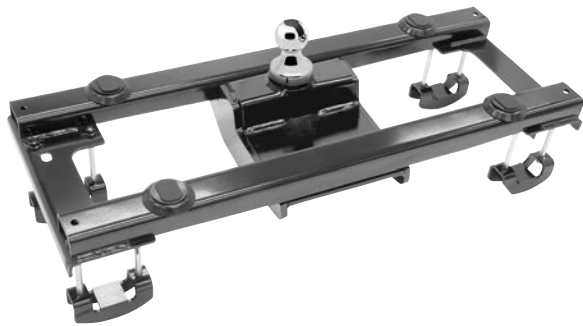

30158-52 - Dodge / RAM Application

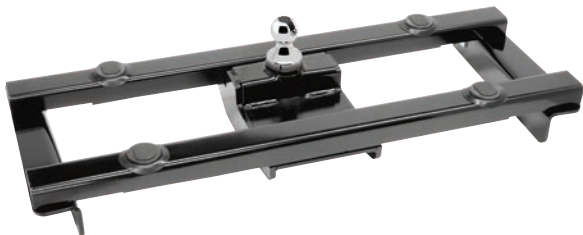

30158-68 - Chevrolet / GMC Application

Part Number	Description	Capacity (lbs.)	Packaging	Master Carton
30138-26	Elite Gooseneck Complete Hitch (Includes #30126 Rail and Pop-in Ball Kit)	25,000	Boxed	1
30138	Elite Gooseneck Head with Pop-In 2-5/16" Ball (Use with #30126 Rail Kit)	25,000	Boxed	1
30158-68	Elite Gooseneck Complete Hitch (Includes #30868 Rail and Pop-in Ball Kit)	25,000	Boxed	1
30158	Elite Gooseneck Head with Pop-In 2-5/16" Ball (Use with #30852 or #30868 Rail Kit)	25,000	Boxed	1
30158-52	Elite Gooseneck Complete Hitch (Includes #30852 Rail and Pop-in Ball Kit)	25,000	Boxed	1
30158	Elite Gooseneck Head with Pop-In 2-5/16" Ball (Use with #30852 or #30868 Rail Kit)	25,000	Boxed	1

**Your actual weight capacity is limited to the towing vehicle or gooseneck rail kit capacity*

ELITE™ SERIES UNDER-BED GOOSENECK HITCH APPLICATION GUIDE

Make / Model	Style	Years	Rail Part Number	Head Part Number	Combo Kit Part Number
CHEVROLET / GMC					
Silverado Sierra 2500 HD	Except with OEM HD Towing Prep Package	11-19	30868	30158	30158-68
Silverado Sierra 3500 HD	Except with OEM HD Towing Prep Package	11-19	30868	30158	30158-68
DODGE / RAM					
Ram 2500		10-12	30852	30158	30158-52
Ram 3500		10-12	30852	30158	30158-52
FORD					
F-250/350 Super Duty	Except Cab and Chassis	11-16	30126	30138	30138-26
F-450 Super Duty	Except Cab and Chassis	11-16	30126	30138	30138-26

30K

ELITE™ SERIES POP-IN™ BALL KIT



- Ball rated for 30,000 lbs. capacity*
- Pop-In™ Ball – lever inside ball head activates ball bearing locking system, lift and turn lever to unlock and remove ball
- Two safety chain holders



30888

*Your actual weight capacity is limited to the towing vehicle or gooseneck rail kit capacity



30135

19311

30136

Part Number	Description	Packaging	Master Carton
30137	Elite Pop-In Ball Kit, Includes: (1) 2-5/16" Pop-In Ball #19311, (1) Storage Bag, (2) Safety Chain Attachments and (1) Hole Cover	Boxed	1
30140	Elite Series Under-Bed Gooseneck Accessories Kit, RAM OEM Kit Only - Includes: 2-5/16" Pop-In Ball #19311, Storage Bag, Safety Chain Attachments and Hole Cover	Boxed	1
30888	Elite Pop-In Ball Kit- RAM OEM Kit Only, Includes: (1) 2 5/16" Pop-In Ball #19311, (1) Storage Bag, (2) Safety Chain Attachments #30887 and (1) Hole Cover	Boxed	1
Replacement Parts			
30134	Safety Chain Attachment for Elite Under-Bed Gooseneck Hitch	Boxed	1
58468	Safety Chain Attachment for Elite Under-Bed Gooseneck Hitch	Boxed	1
30887	Safety Chain Attachment for Under-Bed Gooseneck, RAM OEM Kit Only	Boxed	1
30145	Safety Chain Attachment for Elite Under-Bed Bolt-On Gooseneck, RAM OEM Kit Only	Poly Bag	1
30136	Hole Cover for Elite Under-Bed Gooseneck Hitch	Boxed	1
30135	Storage Bag for Elite Under-Bed Bolt-On Gooseneck 2-5/16" Pop-In Ball #19311	Poly Bag	1
19315	1" High Rise, 2-5/16" Pop-In Ball for Elite Under-Bed Gooseneck Hitch (Not for use with GM factory installed rail systems)	Boxed	1
19311	2-5/16" Pop-In Ball for Elite Under-Bed Gooseneck Hitch	Boxed	1
19314	3" Pop-In Ball for Elite Under-Bed Gooseneck Hitch	Boxed	1

HI-RISE™ CONVERSION HITCH

- Converts a gooseneck hitch into a fifth wheel hitch
- 18,000 lbs. capacity / 4,500 lbs. pin weight capacity
- 4-way pivoting head with self latching jaw design
- 4 degree side-to-side pivot for better control
- 2 bolts for bed height adjustments
- Offset legs enhance performance while braking
- Adjustable stabilizer strips fit bed corrugation pattern
- Lockable, extended length handle
- Only works with B&W gooseneck hitch and REESE® (94XX) series heads utilizing (44XX) series rails

18K



9480

Part Number	Description	Capacity (lbs.)	Vertical Adjustment (in.)	Packaging	Master Carton
9480	Hi-Rise Conversion Hitch	18,000	14-1/4 to 18	Boxed	1
Replacement Parts					
58438	Stabilizer Strips			Boxed	1
117300	Elite Fifth Wheel Head Kit			Boxed	1

NOTE: Not rated for use with Sidewinder

DRAW-TITE® GOOSENECK HITCH SYSTEMS

- Draw-Tite® has designed a number of Gooseneck Hitch Systems to meet your gooseneck towing needs. The secret of the system is in the rail kit. We've designed rail kits to fit your specific truck that can attach to your choice of: Hide-A-Goose™, Fold-Down or Remov-A-Ball® heads.
- Easy install, reliable service
- Same rail kit - 3 methods of head attachment (use fit guide on page G-7 and select your vehicle)
 - Option #1 Hide-A-Goose™ – ball stores in truck bed
 - Option #2 Fold-Down – ball folds down in truck bed
 - Option #3 Remov-A-Ball® – ball removes and is stored separately



30K



9460
9464



9465



9466



9467



9468



30K HIDE-A-GOOSE™ GOOSENECK HITCH HEAD

- Rated up to 30,000 lbs. gross trailer weight and 7,500 lbs. vertical load, tested to SAE J2638 Static and REESE® Dynamic Specs
- Allows full use of pick-up bed area when hauling cargo
- No alteration of OE exhaust systems required
- Accommodates all standard vehicle suspensions
- 2-5/16 in. high strength chrome plated ball standard, 3 in. ball optional
- Magnetic cover protects ball hole when not in use
- Dynamic Specs for 30,000 lbs. gross vehicle weight rating
- Rail kits to match manufacturer's vehicle weight ratings
- Spring loaded safety chain loops included
- Requires installation rail kit



Part Number	Description	Weight Rating (lbs.)	Pin Capacity (lbs.)	Packaging	Master Carton
9460	Hide-A-Goose Wide Hitch Head	30,000	7,500	Boxed	1
9465	Hide-A-Goose Narrow Hitch Head	30,000	7,500	Boxed	1
9464	Hide-A-Goose Wide Hitch Head	30,000	7,500	Boxed	1
9466	Hide-A-Goose Hitch Head for Ram 3500	30,000	7,500	Boxed	1
9467	Hide-A-Goose Hitch Head for Ram 2500	20,000	5,000	Boxed	1
9468	Hide-A-Goose Hitch Head for Ford Super Duty 17-19	32,500	7,500	Boxed	1

25K

25K FOLD-DOWN GOOSENECK HITCH HEAD

- Access Fold-Down design allows unrestricted use of the truck bed when not towing
- Platform and ball rated for 25,000 lbs. gross vehicle towing weight and 6,250 lbs. vertical load
- Takes only seconds to raise or lower the ball into position
- 2-5/16 in. high strength chrome plated ball standard
- Includes mounting hardware and integrated drop down spring loaded safety chain loops
- Oversize pull ring allows user to raise or lower the ball while wearing gloves
- Integrated grease fitting is visible and easily accessible
- Rail kits to match manufacturer's vehicle weight ratings
- No alteration of factory exhaust systems required
- Requires installation rail kit



8339



Part Number	Description	Weight Rating (lbs.)	Pin Capacity (lbs.)	Packaging	Master Carton
8339	Fold-Down Gooseneck Hitch Head	25,000	6,250	Boxed	1

30K

30K REMOV-A-BALL® GOOSENECK HITCH HEAD



- Allows full use of pick-up bed area when hauling cargo
- In-truck platform is rated for 30,000 lbs. gross trailer weight and 7,500 lbs. vertical load and tested to V.E.S.C.-19 specs for 30,000 lbs. gross vehicle weight rating
- No alteration of OE exhaust systems required
- Accommodates all standard vehicle suspensions
- 2-5/16 in. high strength zinc plated ball standard
- Spring loaded chrome sliding pin ensures positive ball lock
- Lockable to prevent ball theft (lock not included)
- Magnetic cover protects ball hole and activating lever slot when not in use
- In-truck platform may be used with rail kits or installed directly to any vehicle with adequate securing structure
- Rail kits are rated to match manufacturer's vehicle weight ratings
- Spring loaded safety chain loops included
- Requires installation rail kit



6300



Part Number	Description	Weight Rating (lbs.)	Pin Capacity (lbs.)	Packaging	Master Carton
6300	Remov-A-Ball Gooseneck Hitch	30,000	7,550	Boxed	1

DRAW-TITE® GOOSENECK HITCH SYSTEM APPLICATION GUIDE

Make/Model	Style	Years	Rail	FN	Head	Combo Kit	Fold-Down	Remov-A-Ball
CHEVROLET/GMC								
C/K Series	Except Crew Cab	88-00	4440	KE	9465	9465-40	8339	6300
Silverado/Sierra 1500	LD (Old Body Style) Does Not Fit MagneRide Magnetic Ride Suspension	99-19	4454	TV	9465	9465-54	8339	6300
Silverado/Sierra 1500 HD	(Classic)	01-07	4454		9465	9465-54	8339	6300
Silverado/Sierra 2500		99-04	4434		9465	9465-34	8339	6300
Silverado/Sierra 2500	6.6 ft. Bed	99-04	4454		9465	9465-54	8339	6300
Silverado/Sierra 2500 HD		01-10	4434		9465	9465-34	8339	6300
Silverado/Sierra 2500 HD	Except with OEM HD Towing Prep Package	11-19	4456	KH	9465	9465-56	8339	6300
Silverado/Sierra 3500	8 ft. Bed	01-07	4445		9465	9465-45	8339	6300
Silverado/Sierra 3500 HD		07-10	4434		9465	9465-34	8339	6300
Silverado/Sierra 3500 HD	Except with OEM HD Towing Prep Package	11-19	4456	KH	9465	9465-56	8339	6300
DODGE/RAM								
Ram 1500		94-01	4439		9460	9460-39	8339	6300
Ram 1500	Except Mega Cab	02-08	4438		9464	9464-38	8339	6300
Ram 1500	Mega Cab	06-08	4435	JR	9464	9464-35	8339	6300
Ram 1500		09-10	4446		9464	9464-46	8339	6300
Ram 1500	Except w/Air Suspension (Classic)	11-20	4446		9464	9464-46	8339	6300
Ram 2500		94-02	4439		9460	9460-39	8339	6300
Ram 2500		03-12	4435	JR	9464	9464-35	8339	6300
Ram 2500		10-13	4457	JR, TX	9464	9464-57	8339	6300
Ram 2500	Head Does Not Require Rail Kit	14-18	-		9467	-	-	-
Ram 3500		94-02	4439		9460	9460-39	8339	6300
Ram 3500		03-12	4435	JR, TX	9464	9464-35	8339	6300
Ram 3500		10-12	4457		9464	9464-57	8339	6300
Ram 3500	Head Does Not Require Rail Kit	13-18	-		9466	-	-	-
FORD								
F-150		04-14	4437		9465	9465-37	8339	6300
F-150	Except Raptor	15-20	4491		9465	9465-91	-	-
F-250/350 Super Duty	Except Cab & Chassis	99-16	4448		9460	9460-48	8339	6300
F-250/350 Super Duty	Except Cab & Chassis	99-16	4449		9460	9460-49	8339	6300
F-250/350 Super Duty	Except Cab & Chassis	17-20	4494	JR	9468	9468-94	8339	6300
F-450 Super Duty	Except Cab & Chassis	08-16	4449	JR	9460	9460-49	8339	6300
F-450 Super Duty	Except Cab & Chassis	17-20	4494	JR	9468	9468-94	8339	6300
TOYOTA								
Tundra		07-20	4436	JR, TV	9465	9465-36	-	-

JR = Exhaust must be temporarily lowered for installation
 KE = Does not fit 1988-91 4 Dr. Crew Cab models
 KH = Minor heat shield modification may be required
 TV = May require Offset Extension Ball #19308 on trucks with less than a 6 ft. long bed
 TX = This product has a higher load capacity

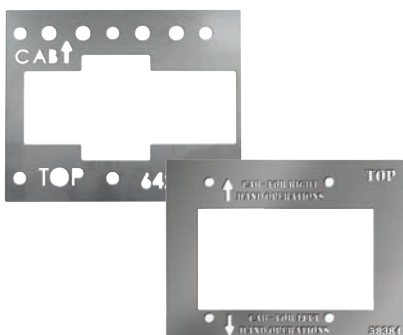

GOOSENECK INSTALLATION TOOLS

Part Number	Description	Packaging	Master Carton
6425	Fold-Down Gooseneck Installation Template for #8339	Bulk	25
58384	Fold-Down Gooseneck Installation Template for #83391 and #83399	Bulk	25
58381	3-1/2" Hole Saw	Bulk	25

25K



30845

ELITE™ SERIES ABOVE-BED GOOSENECK HITCH



- 25,000 lbs. capacity
- 2-5/16 in. high strength zinc plated ball
- Specifically designed for those who employs both fifth wheel and gooseneck trailers
- Mounts to all Elite™ Series Rail Kits
- Above-Bed Gooseneck can be easily removed for unobstructed use of the truck bed
- Weather resistant plastic covering provides protection from the elements and aesthetic appeal
- Built-in chain bracket to accommodate safety chain



Part Number	Description	Capacity (lbs.)	Pin Capacity (lbs.)	Packaging	Master Carton
30845	Elite Series Gooseneck Hitch	25,000	6,250	Boxed	1
Replacement Parts					
58419	Elite Series Gooseneck Service Kit when used on Elite Rail Kits and Ford OEM Under Bed			Boxed	1

NOTE: Will not fit trucks with flareside/stepside

25K



58079

THE GOOSE® ABOVE-BED GOOSENECK HITCH

- In-truck platform rated for 25,000 lbs. gross vehicle towing weight and 6,250 lbs. vertical load
- Easy installation and removal allows for full access to truck bed
- Utilizes same base rails as our fifth wheel hitches
- 2-5/16 in. high strength zinc plated ball
- Rails and installation kit sold separately (30035)



Part Number	Description	Capacity (lbs.)	Pin Capacity (lbs.)	Packaging	Master Carton
58079	The Goose Above-Bed Gooseneck Hitch	25,000	6,250	Boxed	1
58208	Chevrolet Composite Bed Kit for Gooseneck			Boxed	1

25K



49080

STANDARD ABOVE-BED GOOSENECK HITCH

- In-truck platform rated for 25,000 lbs. gross vehicle towing weight and 6,250 lbs. vertical load
- Easy installation and removal allows for full access to truck bed
- Utilizes same base rails as our fifth wheel hitches
- Ball is offset 2 in. to accommodate 6 ft. and 8 ft. truck beds
- 2-5/16 in. high strength zinc plated ball
- Rails and installation kit sold separately (30035)



Part Number	Description	Capacity (lbs.)	Pin Capacity (lbs.)	Packaging	Master Carton
49080	Above-Bed Gooseneck Hitch	25,000	6,250	Boxed	1
49080-024	Above-Bed Gooseneck Hitch, (24 Pack)	25,000	6,250	Boxed	1
58208	Chevrolet Composite Bed Kit for Gooseneck			Boxed	1

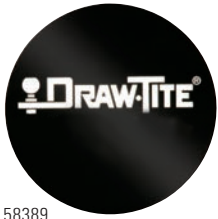

GOOSENECK REPLACEMENT COVERS

Part Number	Description	Packaging	Master Carton
58389	Round Magnetic Cover for Hide-A-Goose	Poly Bag	1
58524	Cover for Hide-A-Goose Gooseneck (Only Works with #9466 and #9467)	Poly Bag	1
5983	Rectangular Magnetic Cover for Remov-A-Ball	Poly Bag	1

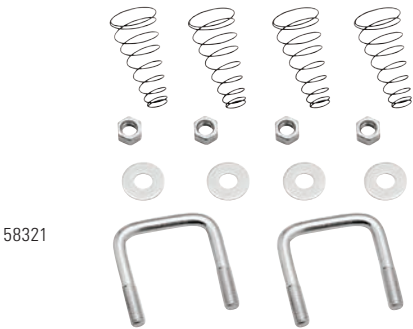

GOOSENECK REPLACEMENT SAFETY CHAIN KITS

Part Number	Description	Packaging	Master Carton
6308	U-Bolt Safety Chain Kit	Poly Bag	1
58312	Gooseneck Head U-Bolt Kit for 94XX Gooseneck Heads	Poly Bag	1
58321	Gooseneck Head U-Bolt Kit for Hide-A-Goose GM HD Gooseneck Heads	Poly Bag	1



GOOSENECK REPLACEMENT HITCH BALLS

Part Number	Description	Packaging	Master Carton
19306	2-5/16" Hitch Ball with 1" Rise for 9460, 9465, and 9464 Gooseneck Heads	Boxed	1
19307	3" Hitch Ball for 9460, 9465, and 9464 Gooseneck Heads	Boxed	1
19308	2-5/16" Hitch Ball with 5" Offset for 9460, 9465, and 9464 Gooseneck Heads	Boxed	1
19309	2-5/16" Hitch Ball for 9460, 9465, and 9464 Gooseneck Heads	Boxed	1
19310	2-5/16" Hitch Ball for Above-Bed Gooseneck	Boxed	1
5973	2-5/16" Hitch Ball for Remov-A-Ball	Boxed	1



GOOSENECK HITCH SYSTEMS

- Gooseneck Hitch Systems conveniently allow unrestricted use of the pickup bed. In-truck platforms support 2-5/16 in. and 3 in. hitch balls. All framework for Gooseneck Trailer Hitches reside under the bed of the truck with only the ball exposed above the bed of the truck. Stronger, and able to utilize the full suspension of the truck, Gooseneck Hitch Systems are rated up to full towing capacity of the vehicle as determined by the manufacturer. Draw-Tite Gooseneck Hitch Systems utilize a unique set of mounting rails, specific to each vehicle, that will accommodate any of the hitch heads.

HOW LARGE OF A TRAILER CAN I TOW?

- Each truck has a published Gross Combined Weight Rating GCWR. This is the maximum allowable tow rating in terms of the combined vehicle and trailer weight. When the Gross Vehicle Weight GVW is subtracted, the maximum Gross Trailer Weight is revealed.
- In this example, the maximum allowable trailer towing weight is 12,800 lbs. GTW. The rail kit for this vehicle has been tested to meet maximum vehicle tow capacity.

COMMON TERMINOLOGY

- **Base Curb Weight** - The nominal weight of a vehicle with standard equipment and a full tank of fuel. It does not include passengers, cargo or optional equipment.
- **Commercial Towing** - Any vehicle/trailer combination exceeding 26,000 lbs. Gross Combined Weight GCW.
- **Commercial Vehicle** - Any vehicle that exceeds 10,000 lbs. GVW.
- **Gross Vehicle Weight (GVW)** - The actual weight of the vehicle when fully loaded. It is the base curb weight plus the cargo weight.
- **Gross Vehicle Weight Rating (GVWR)** - The maximum allowable weight of the fully loaded vehicle.
- **Gross Combined Weight (GCW)** - The actual weight of the vehicle and trailer combined. This weight should always be obtained by weighing the vehicle and trailer together on a scale.
- **Gross Combined Weight Rating (GCWR)** - The maximum weight of the towing vehicle and the loaded trailer - including cargo and passengers.
- **Gross Axle Weight (GAW)** - The total weight supported by each axle (front or rear). To compute this weight for your vehicle and trailer combined, take the loaded vehicle and trailer to a scale. With the trailer attached, place the front wheels of the vehicle on the scale to obtain the front GAW. To obtain the rear GAW, weigh the towing vehicle with the trailer attached, but with just the four wheels of the vehicle on the scale. The rear GAW is determined by subtracting the front GAW from that amount.
- **Gross Axle Weight Rating (GAWR)** - The total weight each axle is capable of carrying. The total load on each axle must not exceed its GAWR.
- **Gross Trailer Weight (GTW)** - The weight of a trailer fully loaded.
- **Maximum Loaded Trailer Weight** - The maximum allowable fully loaded weight of the trailer. This weight is obtained by subtracting the towing vehicle's GVW from its GCWR.
- **Payload** - The combined maximum allowable weight of cargo, occupants and optional equipment that the vehicle is designed to carry. (Gross Vehicle Weight Rating minus the base curb weight.)
- **Rail Kit** - The components and hardware that mount the gooseneck hitch to the vehicle frame.

GCWR - GVW = MAX. GTW

2001 GMC Heavy Duty 2500, 4 Wheel Drive Extended Cab

Engine: Duramax 6600

Horsepower: 300 hp @ 3100 rpm

Torque: 520 ft. lbs. @ 1800 rpm

Transmission: Allison 5-speed Automatic

Axle Ratio: 3.73 to 1

GVW: 9,200 lbs. GCWR: 22,000 lbs.

22,000 lbs. GCWR - 9,200 lbs. GVW = 12,800 lbs. GTW



THE SAE INTERNATIONAL J2638 STANDARD FOR GOOSENECK & FIFTH WHEEL TRAILERS UNDER 30,000 LBS.

The Society of Automotive Engineers (SAE) is a non-profit educational and scientific organization dedicated to advancing mobility technology to better serve humanity. SAE has developed many standards, testing methods and procedures to measure the performance of vehicles and vehicle related products, including trailers. SAE J2638 addresses both gooseneck and 5th wheel trailers under 30,000 lbs. The testing methods for gooseneck are as follows:

Static Testing is a one time maximum load requirement for the three test conditions. The test is to be maintained for 5 Seconds.

- **Vertical** - tests the goosenecks ability with upward & downward pressure
 - 85% of GVW Pull Out (25K lbs. Gooseneck = 21,250 lbs.)
 - 50% of GVW Down (25K lbs. Gooseneck = 12,500 lbs.)
- **Longitudinal** - tests the goosenecks ability with front and back pressure
 - 75% of GVW Front and Back (25K lbs. Gooseneck = 18,750 lbs.)
- **Transverse** - tests the goosenecks ability with side to side pressure
 - 30% of GVW Each Side (25K lbs. Gooseneck = 7,500 lbs)

Dynamic Testing defines requirements for repetitive testing in the three test conditions.

- 300,000 Cycles in each test condition.
 - (Vertical, Longitudinal and Transverse)
- The same unit is used for all three tests.
 - (900,000 Cycles all together)
- The range of load requirements are based on GVW & Rated Coupler Load.

In order to assure safety and accountability for the products produced, SAE J2638 also requires:

- **Product Identification**
 - Manufacturer's Name
 - Rated Vertical Coupler Load
 - Maximum Trailer GVW
 - Ball Size
- **Testing**
 - Products are to be fixtured at the maximum stress conditions
 - There should be no loss of attachment during testing
 - When testing is completed, the coupler will be capable of being uncoupled and coupled

HORIZON GLOBAL COMMITMENT

Horizon Global understands the importance of the new SAE standard for Goosenecks and 5th Wheels. We are committed to providing products that meet or exceed these recommendations and our commitment is evident by our investment in people and facilities dedicated to testing our products.

In addition to being one of the only manufacturers with dedicated testing facilities, Horizon Global also has over 90 years of manufacturing experience to ensure our products are of the highest quality and reliability.

Because of the size of our organization we can provide the added benefits of high quality, unmatched reliability and proven strength, at a competitive price.



PIN BOXES

Founded in 1952, REESE® has become a household name in the heavy-duty towing industry. With proven designs that exceed the industry standards, REESE® has become the brand of choice when performance is the expectation.

REESE® provides the smoothest air-ride pin boxes on the market. Products engineered and designed by the long-time leader in the towing industry that automatically eliminates turning and clearance headaches.

GOOSENECK COUPLER FOR RVs

16K Goose Box™	H-3
20K Goose Box™	H-3
Goose Box™ Accessories	H-3

PIN BOX ACCESSORIES

Custom Wedges	H-6
---------------------	-----

DISCONTINUED PRODUCTS H-7

PIN BOXES

Sidewinder™	H-2
16K 5th Airborne™	H-4
21K 5th Airborne™	H-4
16K Elite™ Airborne™/Sidewinder™ Combo.	H-5

NEW

SIDEWINDER™

The ultimate short bed towing solution REESE® Sidewinder™ is the premium pin box designed specifically for today's short bed pickups. Patent pending design automatically eliminates turning and clearance headaches. Now you can make up to 90-degree plus turns without exiting the truck.

- Sidewinder's king pin locking mechanism moves the pivot position 22 in. rear of the pin box's attachment point. By moving the pivot rearward while keeping the load centered over the axles, the trailer automatically tracks more closely to the truck
- The pivoting pin box makes hook up possible at any angle
- With the towing position of the pin box arm locked in line with the truck, you can make full use of the truck bed space, giving you extra storage space for fuel tanks, toolboxes and cargo
- The C-channel design gives it more stability and strength than the standard pin box design. It also allows better load capacity and the ability to support heavier loads
- Tested for real world conditions, Sidewinder™ has cleared rigorous testing by BOSCH automotive proving grounds and exceeds all SAE/CSA Standard 20K ratings requirements for RVs
- New adjustable wedge, allows for easy adjustment into the funnel of the fifth-wheel
- Fits wing set make and model #'s:
 - Lippert #1621 - Lippert #1621 HD - Lippert #0719
 - Fabex PB 600 Series
- Spacer kit required for installation on:
 - Lippert #1716 - Lippert #1116 - Lippert #0115



68220



20K

Part Number	Description	Capacity (lbs.)	Packaging	Master Carton
68220	Sidewinder Pin Box	20,000	Boxed	1

NOTE: Not all tow vehicle and trailer combinations will allow 90-degree turn



NEW patent pending wedge allows for easy adjustment



Moving pivot point rearward keeps the load centered over the axles



Fits multiple wing set makes and models



Pivoting pin box makes hook up easy at any angle

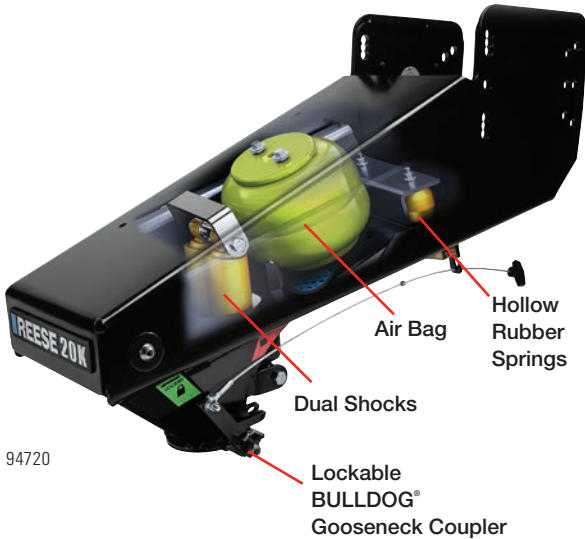

94720

20K



94716

16K

GOOSE BOX™ GOOSENECK COUPLER FOR RVs

Take the heavy equipment out of the truck bed!
The Goose Box™ gooseneck coupler is specifically designed for RV trailer owners who wish to tow with their gooseneck hitch.

- Replaces a traditional pin box so the RV works with a gooseneck hitch
- Step up to RV comfort and keep your gooseneck hitch
- Endorsed by Lippert Components, Inc. for their frame systems
- 5th Airborne™ technology for superior ride performance
- Lockable BULLDOG® gooseneck coupler
- Improved air bag, dual shocks and hollow rubber springs provide multi-directional shock absorption
- Increased height adjustment capability for today's taller truck beds
- Easy reach lanyard
- Onboard safety chain storage
- Air pressure relief valve prevents overfilling
- Rated for 16K and 20K lbs. capacity utilizing both CSA and SAE J2638 test standards
- Patented and patents pending
- Fits wing set make and model #'s:
 - Lippert #1621 - Lippert #1621 HD - Lippert #0719
 - Fabex PB 600 Series
- Spacer kit required for installation on:
 - Lippert #1716 - Lippert #1116 - Lippert #0115



Part Number	Description	Capacity (lbs.)	Packaging	Master Carton
94716	Goose Box For Lippert #1621 and #1716 Wing Sets	16,000	Boxed	1
94720	Goose Box For Lippert #1621 and #1716 Wing Sets	20,000	Boxed	1
Accessory Parts				
49150	Safety Chain Kit, Contains: (2) Grade 70, 5/16" x 44" with 5/16" Clevis Hook and Mounting Hardware	16,000	Barrel	1
49151	Safety Chain Kit, Contains: (2) Grade 70, 5/16" x 44" with 5/16" Clevis Hook and Mounting Hardware	20,000	Barrel	1
61301	Spacer Kit		Boxed	1



Automatically locks when coupling



Lockable BULLDOG® coupler for added security



Increased height adjustment for taller truck beds

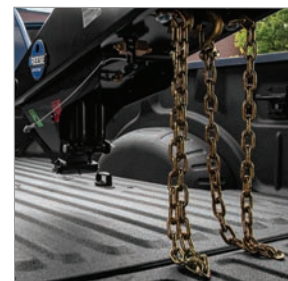

Safety chains with clevis hook and storage on unit

5TH AIRBORNE™

Make your next getaway a breeze. Your fifth wheel takes a lot of abuse from turbulence caused by potholes, section dividers, bridge decks and heavily worn interstate highways.

- The 5th Airborne™ premium fifth wheel air-ride pin box acts as a buffer between the tow vehicle and the trailer, minimizing the challenges in the road. This significantly reduces the negative impact of vertical shock and longitudinal chocking
- Protects your investments by relieving stress on your coach's frame, cabinets, mechanical, and support mechanisms
- Drivers and passengers also benefit from reduced fatigue and the improved safety provided by the 5th Airborne's smooth ride
- Engineered and developed by long-time veterans of the towing industry



21K

21K 5TH AIRBORNE™

5AB-S500-700



Part Number	Application	Capacity (lbs.)	Packaging	Master Carton
5AB-S500-700	- Fabex 500 Series STD - Lippert 1116 and 0115 - RBW 7019	21,000	Boxed	1
5AB-E510-710	- Fabex 500 Series EXT and 765 - Lippert 1716 - RBW 7028	21,000	Boxed	1
5AB-E1621-610	- Fabex 665 - M&M 665 - Lippert 1621, 61621 HD and 1621 HD	21,000	Boxed	1

5AB-E1621-610



⚠ WARNING

Check compatibility of your fifth wheel hitch with The Sidewinder or 5th Airborne Sidewinder. For Reese compatibility information visit our website at: REESEproducts. Refer to the specific product page for Sidewinder or 5th Airborne Sidewinder for up to date fifth wheel hitch compatibility or contact Technical Service.

16K

16K 5TH AIRBORNE™

5AB-E1621-16K



Part Number	Application	Capacity (lbs.)	Packaging	Master Carton
5AB-E1621-16K	-Lippert 1621*	16,000	Boxed	1

*Excluding HD models

ELITE™ AIRBORNE™/SIDEWINDER™ COMBO



The best of both worlds. The REESE® Elite™ Airborne™ combined with the Sidewinder™ is the ultimate pin box. It provides the smoothest ride on the market and automatically eliminates turning and clearance headaches.

- Provides all the benefits of the REESE® 5th Airborne™ air-ride technology and the REESE® Sidewinder™ pin box
- Enhances maneuverability and comfort
- Takes the worry out of traveling with a fifth wheel trailer
- Durable, lasting design for years of trouble free use
- 90-plus degree** turning with a short bed truck
- SAE/CSA rated 16K



16K



61412



61422



61452

Part Number	Application	Capacity (lbs.)	Packaging	Master Carton
Complete Kit				
61412	- Fabex 500 and 700 Series - Lippert 1116, 0115 and 1716 - RBW 7019 and 7028	16,000	Boxed	1
61422	- Fabex 600 Series - Lippert 0719, 1621 and 1621 HD* - M&M 663 and 665	16,000	Boxed	1
61452	- Venture CJ13515 and CJ13517 - Dexter 221-0033-00 and 221-0031-00	16,000	Boxed	1
ST400-5AS16K	- Leland 7910, 7920 and 7921	16,000	Boxed	1
Turret				
61300	- Fabex 500, 600 and 700 Series - Lippert 0719, 1116, 0115, 1716, 1621 and 1621 HD* - RBW 7019 and 7028 - M&M 663 and 665	16,000	Boxed	1
61302	- Venture CJ13515 and CJ13517 - Dexter 221-0033-00 and 221-0031-00	16,000	Boxed	1
ST400	- Leland 7910, 7920 and 7921	16,000	Boxed	1
Spacer Kit				
61301	- Fabex 500 and 700 Series - Lippert 1116, 0115 and 1716 - RBW 7019 and 7028	16,000	Boxed	1
Arm with King Pin				
5AS16K	- Fabex 500, 600 and 700 Series - Lippert 0719, 1116, 0115, 1716, 1621 and 1621 HD* - RBW 7019 and 7028 - M&M 663 and 665 - Venture CJ13515 and CJ13517 - Dexter 221-0033-00 and 221-0031-00 - Leland 7910, 7920 and 7921	16,000	Boxed	1
Rebuild Kit				
94316	- Fabex 500, 600 and 700 Series - Lippert 0719, 1116, 0115, 1716, 1621 and 1621 HD* - RBW 7019 and 7028 - M&M 663 and 665 - Venture CJ13515 and CJ13517 - Dexter 221-0033-00 and 221-0031-00 - Leland 7910, 7920 and 7921	16,000	Boxed	1

**Warning: Not all vehicles and trailer combinations will allow a 90-plus degree turn.

*Not to exceed 16K GTWR

CUSTOM WEDGES

- Designed to work with the Sidewinder™ and Elite™ Airborne™ / Sidewinder™
- Replacement wedge that is designed for specific fifth wheel hitches

Part Number	Description	Packaging	Master Carton
SWW-01	Custom Wedge for Elite Series and Reese 20K Fifth Wheels	Boxed	1
30850	Custom Wedge for Slide-Bar Style Fifth Wheels	Boxed	1
SWW-03	Custom Wedge for Reese 16K Fifth Wheels (Dual Jaw, Except Titan)	Boxed	1
30865	Custom Wedge for Reese Sidewinder and Reese Titan Fifth Wheels	Boxed	1
SWW-04	Custom Wedge for Original Husky Fifth Wheels	Boxed	1
SWW-05	Custom Wedge for Hi-Jacker Fifth Wheels	Boxed	1
SWW-06	Custom Wedge for B&W Fifth Wheels	Boxed	1
SWW-07	Custom Wedge for RBW and Newer Husky Fifth Wheels	Boxed	1
SWW-08	Custom Wedge for Colibert Fifth Wheels	Boxed	1
SWW-09	Custom Wedge for PullRite Fifth Wheels	Boxed	1
31016	Custom Wedge for Curt A16	Boxed	1
30861	Custom Wedge for Curt E16	Boxed	1



SIDEWINDER™

LAST CHANCE



61410†



61420†



61411†



61421†

Part Number	Description	Substitute Part Number	Packaging	Master Carton
16K Complete Kit				
61410†	- Fabex 500 and 700 Series - Lippert 1116, 0115 and 1716 - RBW 7019 and 7028	61412	Boxed	1
61420†	- Fabex 600 Series - Lippert 0719, 1621 and 1621 HD* - M&M 663 and 665	61422	Boxed	1
61450†	- Venture CJ13515 and CJ13517 - Dexter 221-0033-00 and 221-0031-00	61450	Boxed	1
ST400-SW16K†	- Leland 7910, 7920 and 7921	ST400-5AS16K	Boxed	1
19K Complete Kit				
61411†	- Fabex 500 and 700 Series - Lippert 1116, 0115 and 1716 - RBW 7019 and 7028	61412	Boxed	1
61421†	- Fabex 600 Series - Lippert 0719, 1621 and 1621 HD* - M&M 663 and 665	61422	Boxed	1
ST400-SW19K†	- Leland 7910, 7920 and 7921	ST400-5AS16K	Boxed	1
Spacer Kit for 16K and 19K				
61301†	- Fabex 500 and 700 Series - Lippert 1116, 0115 and 1716 - RBW 7019 and 7028	-	Boxed	1
Arm with King Pin				
SW16K†	- Fabex 500, 600 and 700 Series - Lippert 0719, 1116, 0115, 1716, 1621 and 1621 HD* - RBW 7019 and 7028 - M&M 663 and 665 - Venture CJ13515 and CJ13517 - Dexter 221-0033-00 and 221-0031-00 - Leland 7910, 7920 and 7921	-	Boxed	1
SW19K†	- Fabex 500, 600 and 700 Series - Lippert 0719, 1116, 0115, 1716, 1621 and 1621 HD* - RBW 7019 and 7028 - M&M 663 and 665 - Leland 7910, 7920 and 7921	-	Boxed	1
Rebuild Kit for SW16K and SW19K				
86005†	- Fabex 500, 600 and 700 Series - Lippert 0719, 1116, 0115, 1716, 1621 and 1621 HD* - RBW 7019 and 7028 - M&M 663 and 665 - Leland 7910, 7920 and 7921	-	Boxed	1

*Not to exceed GTWR

† = Available while supplies last



CARGO MANAGEMENT

ROLA® is your source for all things cargo management when you're "on the road". ROLA's selection of rugged yet stylish items help you transport gear on your vehicle's roof, hitch or inside the back, and always in style. For the best bike carriers, cargo baskets & bags, roof racks, luggage carriers, organizers and accessories, ROLA® has you covered. ROLA® - just add adventure™

UNIVERSAL ROOF RACKS I-3

ROOFTOP CARGO CARRIERS

V-Tex™ Cargo Basket.....	I-3
Atlas™ Cargo Basket.....	I-4
Rooftop Cargo Bags.....	I-4

HITCH MOUNTED CARGO CARRIERS

Adventure System®.....	I-5
Dart™ Cargo Tray.....	I-5
Vortex™ Cargo Tray.....	I-5 - I-6

CARGO BAGS

Wallaroo™ Cargo Bag.....	I-7
Tuffbak™ Cargo Bag.....	I-7

BIKE CARRIERS

Q-Slot™ Series.....	I-7
Convoy™ Modular.....	I-8
TX™ Series.....	I-8

WATERCRAFT CARRIERS

J-Rac Kayak Carrier.....	I-9
Hull-Hauler™.....	I-9

TRUCK RACKS

Van Racks.....	I-9
Truck Bed Racks.....	I-10
T3 Truck Bed Racks.....	I-10
Truck Bed Rack Accessories.....	I-10

CARGO SECURING

Light Duty Ratchet Straps.....	I-11
Standard Duty Ratchet Straps.....	I-11
Heavy Duty Ratchet Straps.....	I-11
Super Duty Ratchet Straps.....	I-12
Retractable Ratchet Straps.....	I-12
Cargo Nets.....	I-12
Marine Tie Downs.....	I-15

ACCESSORIES

Cargo Carrier Accessories.....	I-13
Vehicle Organizers.....	I-13
Tow Straps.....	I-14
Anchor Shackles.....	I-14
Tree Saver Strap.....	I-14
Aluminum Ramps.....	I-14

DISCONTINUED PRODUCTS..... I-16 - I-17

NEW

RATCHET STRAPS

Draw-Tite® high quality ratcheting tie downs provide strong holding power and precise tension adjustment. They are simple and easy to use. Just attach, pull the webbing tight and pump the handle. Quality designed for long life and increased safety.

- Up to 3,300 lbs. working load; 10,000 lbs. capacity
- Ideal for securing motorcycles, ATVs, and golf carts to lawn tractors, building materials and UTVs
- Constructed from rugged casted aluminum
- Vinyl coated steel hooks won't scratch or mar
- See page I-11 for additional information



FEATURED

RAMBLER™ CARGO CARRIERS

A hitch mounted cargo tray is an excellent way to create extra carrying capacity on your vehicle. Use it to carry sports gear, camping or lawn equipment, extra luggage and anything else you don't want taking up precious space inside your vehicle. Cargo trays are also great for hauling items that don't fit in your vehicle, like bulky coolers. REESE® manufactures a rust-resistant steel hitch mounted cargo tray that's easy to assemble using the included hardware. Best of all, they're easy to access, load and unload.

- Mounts to vehicle's receiver hitch
- 5-1/2 in. side rails
- Easy to access, load and unload
- Heavy-duty construction
- Black powder coat finish resists rust
- All hardware included
- See page I-6 for additional information



HELPFUL HINTS FOR TRANSPORTING GEAR ON YOUR ROOF

Know your vehicle's roof

- Cargo bags mount to raised side rails, cross bars or rooftop baskets
- Rooftop baskets require cross bars

Choose the proper cargo bag

- Everyday Protection – for wind, dust and sun
- Rainproof Protection – for rain, snow, wind, dust and sun
- Stormproof Protection – for heavy rain, snow, dust and sun

Try your bag before you travel

- Adjust strap length and placement on raised side rails and/or cross bars
- Make sure contents fit into bag without overstuffing

How to load your bag

- Attach cargo bag to rooftop first—then load
- Keep all valuables in vehicle's interior
- Do not exceed your vehicle's rated roof capacity

1390100



RBUS3

RBUSERIES UNIVERSAL ROOF RACK

- Built from super rugged, lightweight aluminum and expertly engineered for optimal aerodynamics to cut down on drag and wind noise
- Anodized aluminum crossbars, high strength molded nylon and stainless steel hardware
- Anti-theft locking covers for peace of mind
- Lockable accessory channel for T-bolt applications
- Quick and easy installation and removal
- Includes cross bars and end supports

Part Number	Cross Bar Length (in.)	Side Rail Fit Range (in.)	Packaging	Master Carton
RBUS43	43-3/8	30-7/8 to 40-7/8	Litho Box	1
RBUS47	47-1/4	34-3/4 to 44-3/4	Litho Box	1
RBUS53	53-1/8	40-5/8 to 50-5/8	Litho Box	1
RBUS60	61-5/8	49-1/8 to 59-1/8	Litho Box	1
Accessories				
59315	Roof Rack Lock Kit, (4 Pack)		Litho Box	1
59316	Roof Rack Lock Kit, (8 Pack)		Litho Box	1

V-TEX™ ROOFTOP CARGO BASKET

- Provides extra cargo capacity on vehicle rooftop
- Custom fit wind fairing improves aerodynamics and reduces wind noise
- Rough-coat finish protects against the elements and resists scratches
- Heavy-duty steel construction
- Adjustable brackets fit most cross bars



59504

Part Number	Description	Dimensions (in.)	Capacity (lbs.)	Packaging	Master Carton
59504	Steel Cargo Basket	48 x 37.5 x 5	130	Litho Box	1
59505	Steel Cargo Basket Extender	22.75 x 18.75	130	Litho Box	1



59043

ATLAS™ ROOFTOP CARGO BASKET

- Lightweight construction for easy handling and mounting
- 2 removable interior cross bars for mounting accessories
- Side rail tie down points to easily secure gear
- Custom wind fairing reduces wind noise
- Rust-resistant finish aluminum construction
- Mounting hardware included

Part Number	Description	Dimensions (in.)	Capacity (lbs)	Packaging	Master Carton
59043	Aluminum Cargo Basket	56 x 43.5 x 4	160	Litho Box	1

ROOFTOP CARGO BASKETS

- Provide extra cargo space
- Adjustable brackets fit most cross bar styles
- Rust-resistant finish
- Sleek, sporty styling
- Easy to assemble
- All hardware included



1391300

Part Number	Description	Dimensions (in.)	Capacity (lbs)	Packaging	Master Carton
1391300	Rooftop Cargo Basket, 3-Piece with Custom Air Deflector	44 x 35 x 4.25	125	Litho Box	1
1394400	Rooftop Cargo Basket, Low Profile	37.25 x 26.5 x 3.75	100	Litho Box	1

STORMPROOF ROOFTOP CARGO BAG

- Easily attaches to permanent roof racks
- Made of premium quality rainproof material with sonically welded seams
- 15 cubic ft. of storage space
- All installation straps included
- Padded structure helps maintain shape
- Storm flap protects zippers



1390100

Part Number	Description	Dimensions (in.)	Capacity (cu ft.)	Packaging	Master Carton
1390100	Stormproof Shield Rooftop Cargo Bag	40 x 38 x 23	15	Litho Box	2

ROOFTOP CARGO BAGS

- Increase your storage area and free up space in your vehicle
- Easily attach to raised side rails, cross bars and/or rooftop baskets
- Available in a variety of sizes and styles



1391800

Part Number	Description	Dimensions (in.)	Capacity (cu ft.)	Packaging	Master Carton
1391800	Expandable Rooftop Cargo Bag, Rainproof	40 x 38 x 13.5 to 22.5	12 to 16	Litho Box	2
1041000	Rooftop Cargo Bag	37 x 30 x 15.5	10	Litho Box	2
1041100	Rooftop Cargo Bag, Rainproof	38 x 38 x 18	15	Litho Box	2

HITCH MOUNTED CARGO TRAYS

TRANSPORT YOUR GEAR WITH A HITCH MOUNTED CARGO CARRIER

Know your vehicle's hitch size

- Cargo carriers are designed to fit 1-1/4 in. or 2 in. receivers

Determine how to best secure your cargo

- Cargo net
- Cargo tray bag
- Ratchet straps

Know the weight of the cargo you are carrying

- Cargo tray fitting a 1-1/4 in. receiver will hold up to 300 lbs.
- Cargo tray fitting a 2 in. receiver will hold up to 600 lbs.



59109

ADVENTURE SYSTEM®

- Provides 13 cu. ft. of extra cargo capacity
- Cargo tray can be used without pod
- Durable construction and locked lid protects gear
- Swing-away design provides rear of vehicle access without removing carrier
- Integrated lights provide stop, turn and tail light functions

Part Number	Description	Dimensions (in.)	Capacity (lbs.)	Packaging	Master Carton
59109	Swing-Away, Fits 2" Receiver	54 x 30 x 22.5	250	Litho Box	1
Replacement Parts					
59510	Latch Kit for Adventure System			Boxed	1



59550

DART™ CARGO TRAY

- Provides extra cargo capacity, using vehicle hitch
- Easy to reach release lever for folding carrier when not in use
- High-impact ABS skid and side plates
- Heavy-duty steel construction
- Rise shank design provides greater clearance

Part Number	Description	Dimensions (in.)	Capacity (lbs.)	Packaging	Master Carton
59550	Fits 2" Receiver	54 x 23 x 5.25	450	Litho Box	1



59502

VORTEX™ CARGO TRAY

- Provides extra cargo capacity, using vehicle hitch
- 5 in. side rails help secure cargo
- Reflectors improve visibility at night
- Heavy-duty steel construction
- Rough-coat finish protects against the elements and resists scratches
- Rise shank design provides greater clearance

Part Number	Description	Dimensions (in.)	Capacity (lbs.)	Packaging	Master Carton
59507	Fits 1-1/4" Receiver	56 x 23 x 5	300	Litho Box	1
59502	Fits 2" Receiver	56 x 23 x 5	600	Litho Box	1



6502

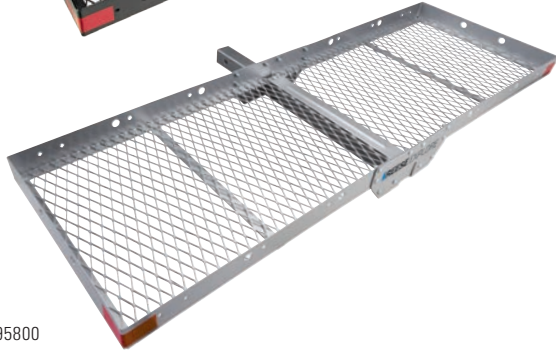

1395800

CARGO TRAY

- Provides extra cargo capacity, using vehicle hitch
- Heavy-duty construction
- Rust resistant finish
- Tilts up for compact storage and easier installation
- Leave on the vehicle without worry of parking
- All hardware included

Part Number	Description	Dimensions (in.)	Capacity (lbs.)	Packaging	Master Carton
6502	Fits 2" Receiver	48 x 20	500	Litho Box	1
1041500	Steel Cargo Tray, Fits 1-1/4" and 2" Receivers with Included Adapter	60 x 20	500	Litho Box	1
1394500	Steel Cargo Tray, Fits 2" Receivers	60 x 20	500	Litho Box	1
1395800	Aluminum Cargo Tray, Fits 2" Receivers	60 x 20	500	Litho Box	1



63153



63155

RAMBLER™ CARGO CARRIERS

- Great for carrying sports gear, lawn and garden supplies, and camping equipment
- Mounts to vehicle's receiver hitch
- 5-1/2 in. side rails
- Easy to access, load and unload
- Heavy-duty construction
- Black powder coat finish resists rust
- All hardware included

Part Number	Description	Dimensions (in.)	Capacity (lbs.)	Packaging	Master Carton
63153	Rambler Cargo Carrier, Bolt-Together, Fits 2" Receivers	60 x 24	500	Litho Box	1
63155	Rambler Cargo Carrier, Bolt-Together, Fits 1-1/4" Receivers	48 x 20	300	Litho Box	1

CARGO TRAY BAGS

- Perfect for hauling camping gear, sports equipment and tailgating supplies
- Rainproof storage for cargo trays
- Includes straps for secure attachment to most cargo trays
- Made with premium, quality materials
- Sonically welded construction
- Folds flat for easy storage



63604

Part Number	Description	Dimensions (in.)	Capacity (cu ft.)	Packaging	Master Carton
63604	Cargo Tray Bag	59 x 18.5 x 24	15	Litho Box	2
1043000	Cargo Tray Bag	54 x 20 x 21	13	Litho Box	2

59102



WALLAROO™ CARGO BAG

- Rainproof construction
- Protects cargo during transport
- Multiple zippers allow bag capacity to expand from 9.5 to 11.5 cu. ft.
- Expandable 18 in. to 22 in. height
- Storm flap conceals zipper
- 6 straps for secure attachment
- Perfect fit with ROLA® hitch mounted cargo trays

Part Number	Description	Dimensions (in.)	Capacity (lbs.)	Packaging	Master Carton
59102	Expandable Cargo Bag	48 x 19 x 18-22	9.5 - 11.5	Litho Box	1

59119



TUFFBAK™ CARGO BAG

- Rainproof construction
- Protects cargo during transport
- Extra large capacity fits 29 in. x 24 in. cargo carriers
- Storm flap conceals zipper
- 6 straps for secure attachment
- Perfect fit with ROLA® hitch mounted cargo trays

Part Number	Description	Dimensions (in.)	Capacity (lbs.)	Packaging	Master Carton
59119	Cargo Bag	59 x 24 x 24	20	Litho Box	1

63134



Q-SLOT™ BIKE CARRIERS

The Q-Slot™ steel hitch mount bike rack holds up to four bicycles. The platform design holds bikes in the upright position. The support tube with adjustable padded hooks support bikes by the frame. Rear wheels are secured with hook and loop straps. The rise shank provides greater ground clearance. The support tube folds down when not in use. Versatile design is available for both 1-1/4 in and 2 in. receivers with a max capacity of 140 lbs.

- Will not damage high-performance frames
- Fully adjustable wheel slots
- Carries most bikes regardless of the frame style
- Rise shank for extra road clearance
- Padded contact points
- Bolt-on 2 in. shank adapter (2 bike carrier only)
- Folds for compact storage
- Center post tilt for easy bike loading and unloading
- Rear reflectors for nighttime visibility

63138



Part Number	Description	Capacity (lbs.)	Packaging	Master Carton
63134	Q-Slot 2 Bike Carrier, Fits 1-1/4" and 2" Receivers	90	Litho Box	1
63138	Q-Slot 4 Bike Carrier, Fits 2" Receivers	140	Litho Box	1
Replacement Parts				
63135	Q-Slot Bike Carrier Hook and Loop Strap, (4 Pack)		Poly Bag	1

NEW!



CONVOY™ MODULAR BIKE CARRIER

- This new modular design allows you to determine how many bikes you want to carry (1, 2, 3 or 4 bikes). Simply add on to carry more than 1 bike.
- Securely holds a wide variety of bike styles and sizes with a ratcheting arm that can be positioned to hold bikes by the frame or the wheel
- Cradle accommodates road tires to fat tires up to 5 in. wide
- Holds bikes with up to 48 in. wheel base
- Ratcheting arm locks with included lock and key
- Anti-rattle pin dramatically reduces carrier movement in the receiver
- Tiered design for greater ground clearance and spacing between bikes
- Easy to store with its user-friendly design, allowing it to fold up when not in use or drop down for access to the rear of the vehicle
- Corrosion-resistant aluminum construction



Tiered "Add A Rack" Design



Lock and Key Included



Holds Tires up to 5 in. Wide



Holds up to 4 Bikes

Maximum Capacity Per Unit, Add-On Unit is Required to Carry Multiple Bikes							
Part Number	Description					Packaging	Master Carton
59308	Base Unit, Fits 2" Receiver	80 lbs.	75 lbs.	55 lbs.	45 lbs.	Litho Box	1
59307	Base Unit, Fits 1-1/4" Receiver	50 lbs.	50 lbs.	-	-	Litho Box	1
59310	Add-On Unit	-	75 lbs.	55 lbs.	45 lbs.	Litho Box	1



TX™ BIKE CARRIERS

- Versatile cradles fit most bike frames, styles and sizes
- Anti-sway rollers reduce bike movement
- Rack tilts providing access to rear of vehicle
- Integrated cable lock secures bikes
- Arms fold down when not in use
- Heavy-duty steel construction

Part Number	Description	Capacity (lbs.)	Packaging	Master Carton
59400	TX 2 Bike Carrier Fits 1-1/4" and 2" Receivers	80	Litho Box	1
59401	TX 4 Bike Carrier Fits 2" Receiver	100	Litho Box	1
Replacement Parts				
59405	TX Bike Carrier Strap, (2 Pack)		Poly Bag	1
59406	TX Bike Carrier Cradle		Poly Bag	1
59407	TX Bike Carrier Anti-Sway Cradle and Strap		Poly Bag	1



1394900

J-RAC KAYAK CARRIER

The J-Rac kayak carrier attaches to most crossbars and secures the kayak in an upright position. The carrier includes two J-Rac holders and securing straps and mounting hardware are included. It has a capacity of 165 lbs. Holds a single kayak in the upright position

- Heavy-duty powder coated steel construction
- Foam pads cradle and protect kayak during transport
- Universal hardware fits most crossbars
- Premium straps and bow/stern tie-downs included

Part Number	Description	Capacity (lbs.)	Packaging	Master Carton
1394900	J-Rac Kayak Carrier	165	Litho Box	1



59913

HULL-HAULER™ WATERCRAFT CARRIER

- Multi-pivot rubber saddle system adjusts and conforms to almost any kayak shape and size for a customized, secure fit every time
- Pivoting saddles make loading and unloading watercraft a total breeze
- Powder coated steel resists rust
- Hardware works with ROLA® and most other crossbars
- Premium heavy-duty straps and bow/stern tie-downs included

Part Number	Description	Capacity (lbs.)	Packaging	Master Carton
59913	Hull-Hauler Watercraft Carrier	-	Litho Box	1
Replacement Parts				
59300	Hull-Hauler Tie Down Kit		Litho Box	1
59302	Hull-Hauler Pivot Knob Assembly		Litho Box	1
59303	Hull-Hauler Bottom Mounting Bracket		Litho Box	1



59623

UNIVERSAL VAN RACK

- Heavy gauge steel construction; perfect for heavy duty and commercial use
- Easy, no drill installation
- Fits all vans with rain gutters; telescopic bars adjust from 37 in. to 62 in. to create the perfect fit
- Powder coated, hammered finish resists the elements, scratches, and rust

Part Number	Description	Capacity (lbs.)	Packaging	Master Carton
59622	V2 Universal Van Rack, Includes (2) Crossbars	300	Litho Box	1
59623	V3 Universal Van Rack, Includes (3) Crossbars	450	Litho Box	1



59742

TRUCK BED RACK

- Lightweight, durable aluminum construction
- Easy, no drill installation
- Powder-coated black uprights and graphite gray anodized cross bars
- Rubber buffer strips protect load from damage
- Compatible with ROLA® rooftop accessory carriers
- Includes 63 in. cross bars with locking end caps and 2 sets of upright supports
- Designed specifically for the Ford F150, Dodge Ram, GMC Sierra and Chevrolet Silverado

Part Number	Description	Capacity (lbs.)	Packaging	Master Carton
59742	Removable Truck Bed Rack	400	Litho Box	1



59799

T3 TRUCK BED RACK

- Lightweight, durable aluminum construction
- Easy, no drill installation
- Powder coated black uprights and stainless steel hardware to resist the elements, scratches, and rust
- Adjustable fore and aft; customizable placement
- Rubber buffer strips protect load from damage
- Locking covers for crossbar accessory channel and locking knobs for slide feature
- Kit includes cross bars with 63 in. maximum width, locking end caps, 2 sets of upright supports and installation hardware
- Designed specifically for the Nissan Titan, Toyota Tundra, and Toyota Tacoma bed rail systems

Part Number	Description	Capacity (lbs.)	Packaging	Master Carton
59799	Removable T3 Truck Bed Rack	800	Litho Box	1



59794

TRUCK BED RACK LOAD STOP KIT

- Ideal for transporting lumber and ladders
- Powder-coated to resist scratches, rust and the elements
- Durable lock-down knobs and stainless steel mounting hardware included

Part Number	Description	Packaging	Master Carton
59794	Truck Bed Rack Load Stop Kit, (4 Pack)	Litho Box	1



59796

TRUCK BED RACK EYE BOLT KIT

- Alloy steel construction is perfect for job site to campsite
- Powder-coated to resist the elements
- Stainless steel hardware included

Part Number	Description	Packaging	Master Carton
59796	Truck Bed Rack Eye Bolt Kit, (4 Pack)	Litho Box	1



LIGHT DUTY RATCHET STRAPS

- 300 lbs. working load; 900 lbs. capacity
- Vinyl coated steel secure hooks for easy attachment
- 1 in. wide webbing
- Secures light cargo for short trip transportation

Part Number	Description	Length (ft.)	Capacity (lbs.)	Packaging	Master Carton
94815DT	Light Duty Ratchet	10	300/900	Bulk PDQ	10
95108DT	Light Duty Ratchet, (4 Pack)	10	300/900	Plastic Shroud	3
94816DT	Light Duty Cambuckle	10	300/900	Bulk PDQ	10
94247DT	Light Duty Cambuckle, (4 Pack)	10	300/900	Plastic Shroud	3



STANDARD DUTY RATCHET STRAPS

- Up to 500 lbs. working load; 1,500 lbs. capacity
- Constructed from rugged casted aluminum
- Vinyl coated steel hooks won't scratch or mar
- 1 in. wide webbing
- Ideal for securing motorcycles, ATVs, generators, and more

Part Number	Description	Length (ft.)	Capacity (lbs.)	Packaging	Master Carton
94828DT	Standard Duty Ratchet with Grip Handle, (4 Pack)	10	500/1,500	Plastic Shroud	3
94853DT	Standard Duty Ratchet with Grip Handle	10	500/1,500	Bulk PDQ	4
95463DT	Standard Duty Ratchet, Endless	12	500/1,500	Bulk PDQ	8
94255DT	Standard Duty Ratchet, Retractable, (2 Pack)	6	500/1,500	Plastic Shroud	3
95111DT	Standard Duty Ratchet, (4 Pack)	12	400/1,200	Plastic Shroud	3



HEAVY DUTY RATCHET STRAPS

- 1,000 lbs. working load; 3,000 lbs. capacity
- Vinyl coated steel secure hooks for easy attachment
- 1 in. wide webbing
- Ideal for lawn tractors, UTVs, golf carts, lumber, and more

Part Number	Description	Length (ft.)	Capacity (lbs.)	Packaging	Master Carton
94260DT	Heavy Duty Ratchet with Comfort Handle, (2 Pack)	14	1,000/3,000	Plastic Shroud	4
94262DT	Heavy Duty Ratchet with Comfort Handle, (4 Pack)	14	1,000/3,000	Plastic Shroud	3
95142DT	Heavy Duty Ratchet with Comfort Handle	14	1,000/3,000	Bulk PDQ	4
94252DT	Heavy Cambuckle, (4 Pack)	14	1,000/3,000	Plastic Shroud	3
94273DT	Heavy Duty Ratchet with 2" Wide Webbing, Retractable	10	1,000/3,000	Bulk PDQ	4

NEW!



95466DT



94824DT

NEW!



94273DT

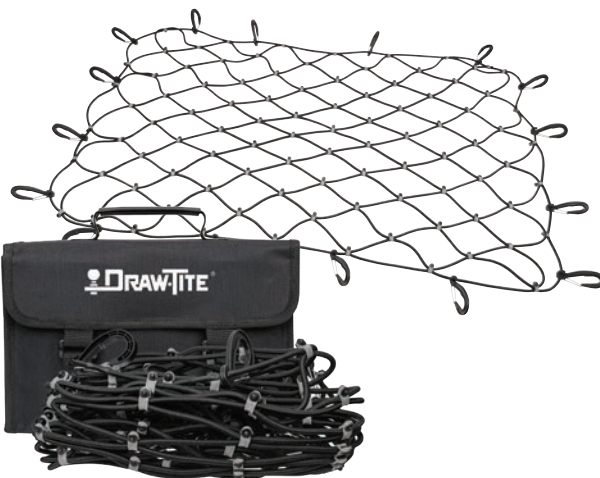

94241DT

SUPER DUTY RATCHET STRAPS

- Up to 3,300 lbs. working load; 10,000 lbs. capacity
- Super strong steel hooks
- Padded grip handle for complete control
- 2 in. wide webbing
- Ideal for heavy equipment, large loads, building materials, UTVs, and more

Part Number	Description	Length (ft.)	Capacity (lbs.)	Packaging	Master Carton
95466DT	Super Duty Ratchet with Flat Hooks and Webbing Keeper	30	3,300/10,000	Bulk PDQ	6
95120DT	Super Duty Ratchet with 1.5" Wide Webbing and Flat Hooks	30	1,830/5,500	Bulk PDQ	4
94824DT	Super Duty Ratchet with J-Hooks	30	3,300/10,000	Bulk PDQ	4
95118DT	Super Duty Ratchet with Camo Webbing and J-Hooks	30	3,300/10,000	Bulk PDQ	4

RETRACTABLE RATCHET STRAPS

- Strap winds into handle with the simple push of a button
- Eliminates mess and tangling of webbing
- Constructed from rugged casted aluminum
- Vinyl coated steel hooks won't scratch or mar

Part Number	Description	Length (ft.)	Capacity (lbs.)	Packaging	Master Carton
94255DT	Standard Duty Ratchet with 1" Wide Webbing, Retractable, (2 Pack)	6	500/1,500	Plastic Shroud	3
94273DT	Heavy Duty Ratchet with 2" Wide Webbing, Retractable	10	1,000/3,000	PDQ Tray	4

CARGO NETS

- Quickly secure complex loads
- Bungee material stretches to fit with rubber protectors
- Exclusive no-tangle hook design
- Rubber gear protectors throughout
- Heavy-duty storage bag included

Part Number	Description	Dimensions (in.)	Packaging	Master Carton
13937DT	Bungee Cargo Net	36 x 48	Litho Box	1
94241DT	Bungee Truck Bed Cargo Net	60 x 78	Litho Box	1
9424200	Universal Heavy Duty Truck Bed Cargo Net	55 x 78	Litho Box	1



59109

FAT STRAP CARGO NET

- Fits roof racks and baskets up to 36 in. x 48 in.
- Wide hook openings fit a variety of racks
- Added loops allow net to fit on any rack or carrier

Part Number	Description	Packaging	Master Carton
59200	Fat Strap Cargo Net, 36" x 48"	Litho Box	1



59516

LED LIGHT KIT

- Provides stop, turn and tail light functions
- Standard 4-Way connector ensures easy setup and use
- Bright, long-lasting 10-diode LED lights

Part Number	Description	Packaging	Master Carton
59516	LED Light Kit	Litho Box	1



20174

INCANDESCENT LIGHT KIT

- Provides stop, turn and tail light functions
- Standard 4-Way connector ensures easy setup and use
- Oval grommets keep the lights in place

Part Number	Description	Packaging	Master Carton
20174	Incandescent Light Kit	Litho Box	1



59904

BIKE MOUNT ADAPTER KIT

- Converts hitch mount cargo basket into a bike carrier
- Adjustable clamp fits most railed cargo baskets
- Includes rear stabilizer mount
- Use up to three mounts on a railed hitch cargo basket

Part Number	Description	Packaging	Master Carton
59904	Bike Mount Adapter Kit, 40 lbs. Capacity	Litho Box	1



59000

VEHICLE ORGANIZER

- Movable interior dividers accommodate a variety of gear
- Adjustable compartments to custom fit your gear
- Mesh outer pockets
- Lashing loops for securing
- Folds flat for convenient storage when not in use
- Rigid base with exclusive non-slip bottom

Part Number	Description	Dimensions (in.)	Packaging	Master Carton
59000	Small Interior Organizer	25 x 15 x 7	Litho Box	1



94623DT

95451DT

TOW STRAPS

- Super strong, flexible webbing
- Reflective, high visibility webbing
- Includes storage bag

Part Number	Description	Dimensions (in. x ft.)	Capacity (lbs.)	Packaging	Master Carton
94263DT	Tow Strap with Hook Ends	2 x 20	3,300/10,000	Sleeve	3
94264DT	Tow Strap with Loop Ends	2 x 20	5,660/17,000	Bulk PDQ	3
95451DT	Tow Strap with Loop Ends	3 x 30	10,000/30,000	Bulk PDQ	2
95167DT	Tree Saver Strap with Loop Ends	3 x 6	10,000/30,000	PDQ Tray	3



95235DT

ANCHOR SHACKLES

- Can be used with towing or recovery straps, ropes and even chains to provide a secure attachment point
- Threaded pin
- Rust-resistant and corrosion resistant

Part Number	Description	Packaging	Master Carton
95235DT	Anchor Shackle, 7/8"	Bulk	4
95236DT	Anchor Shackle, 3/4"	Bulk	4

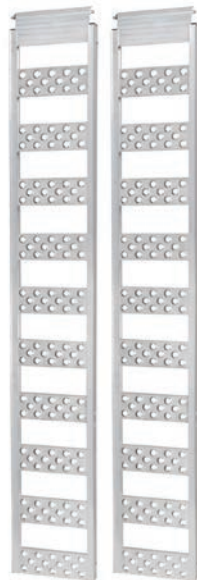

95151DT

ALUMINUM RAMPS

- Patented self-adjusting top plate, hinged top plate creates smooth transitions on and off ramp
- Molded top caps protect tailgate and loading surfaces
- Adjustable attachment straps
- Welded aluminum construction
- Rust-resistant and corrosion resistant

Part Number	Description	Dimensions (in. x ft.)	Capacity Per Pair (lbs.)	Packaging	Master Carton
95151DT	Straight Aluminum Ramp Pair	13 x 84	1,250	Boxed	1
74527DT	Arched Aluminum Ramp Pair	12 x 90	1,500	Boxed	1
95150DT	Arched Centerfold Aluminum Ramp Pair	12 x 90	1,500	Boxed	1



Straight



Arched



Arched Centerfold



2060266

TRANSOM RATCHET TIE DOWNS

- Strap retracts for easy storage and no tangling
- Easy bolt on function (hardware included)
- Some models available with stainless steel housing
- Vinyl coated J-hooks protect boats finish
- Provides super strong holding power

Part Number	Description	Dimensions (in.)	Capacity (lbs.)	Packaging	Master Carton
2060266	Transom Retractable Tie Down, Stainless Steel, (2 Pack)	2 x 43	600	Plastic Shroud	3
2061766	Transom Retractable Tie Down, Zinc	2 x 43	833	Plastic Shroud	24



2060466

TRANSOM SURELOK CAMBUCKLES

- Vinyl coated S-hooks protect boats finish
- Provides super strong holding power
- Locks in place to eliminate slippage
- Protective housing prevents scratches
- Provides super strong holding power

Part Number	Description	Dimensions (in.)	Capacity (lbs.)	Packaging	Master Carton
2060466	Transom Cambuckle Tie Down, Zinc, (2 Pack)	2 x 24	833	Plastic Shroud	3



2061366

2060866

GUNWALE RATCHET TIE DOWNS

- Strap retracts for easy storage and no tangling
- Easy bolt on function (hardware included)
- Vinyl coated J-hooks protect boats finish
- Provides super strong holding power
- Max grip comfort handle

Part Number	Description	Dimensions (in.)	Capacity (lbs.)	Packaging	Master Carton
2060866	Gunwale Tie Down with Max Grip Handle, Zinc	2 x 10	333	Plastic Shroud	3
2061366	Gunwale Tie Down with Max Grip Handle, Zinc	2 x 13	833	Plastic Shroud	3
2061566	Gunwale Tie Down with Max Grip Handle, Zinc	2 x 20	833	Plastic Shroud	3

59110†



ADVENTURE SYSTEM®

LAST CHANCE

Part Number	Description	Substitute Part Number	Packaging	Master Carton
59108†	Fixed, Fits 1-1/4" Receiver	59109	Litho Box	1
59110†	Fold-Up, Fits 2" Receiver	59109	Litho Box	1

ROOFTOP BASKET

LAST CHANCE

Part Number	Description	Substitute Part Number	Packaging	Master Carton
1040900†	Steel Rooftop Cargo Basket, 125 lbs. Capacity	59504	Litho Box	1

59318†



ESCAPE™ ROOFTOP CARGO BAG

LAST CHANCE

Part Number	Description	Substitute Part Number	Packaging	Master Carton
59318†	Expandable Rooftop Bag, 13-16 cu. ft. Capacity	-	Litho Box	1

59100†



PLATYPUS™ ROOFTOP CARGO BAG

LAST CHANCE

Part Number	Description	Substitute Part Number	Packaging	Master Carton
59100†	Expandable Rooftop Bag, 13-16 cu. ft. Capacity	-	Litho Box	1

63124†



ECLIPSE™ BIKE CARRIERS

LAST CHANCE

Part Number	Description	Substitute Part Number	Packaging	Master Carton
63120†	Eclipse 2 Bike Carrier, Fits 1-1/4" Receiver, 66 lbs. Capacity	59400	Litho Box	1
63123†	Eclipse 3 Bike Carrier, Fits 1-1/4" or 2" Receiver, 100 lbs. Capacity	59401	Litho Box	1
63124†	Eclipse 4 Bike Carrier, Fits 2" Receiver, 120 lbs. Capacity	59401	Litho Box	1
63148†	Eclipse Bike Carrier Cradle	59407	Litho Box	1

59403†

TX™ BIKE CARRIER

LAST CHANCE

Part Number	Description	Substitute Part Number	Packaging	Master Carton
59403†	TX 3 Bike Carrier, Fits 1-1/4" and 2" Receivers, 80 lbs. Capacity	59401	Litho Box	1

59306†

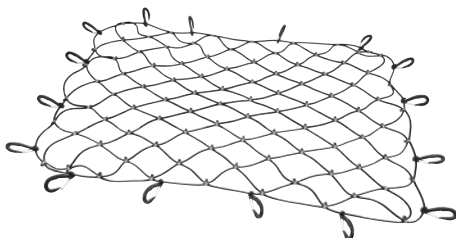

RATCHET CARGO BAR

LAST CHANCE

Part Number	Description	Substitute Part Number	Packaging	Master Carton
1390600†	Ratcheting Cargo Bar, 40" - 70"	-	Boxed	1

BUNGEE CARGO NET

LAST CHANCE

Part Number	Description	Substitute Part Number	Packaging	Master Carton
59306†	Bungee Cargo Net, 36" x 48"	13937DT	Litho Box	1

† = Available while supplies last



RE53†



59976†



59315†



R7001†



59550†



95473DT†

MODULAR ROOF RACKS **LAST CHANCE**

Part Number	Description	Substitute Part Number	Packaging	Master Carton
Cross Bars				
RE43†	Extreme Cross Bar Kit, 43"	RBU43	Boxed	1
RE47†	Extreme Cross Bar Kit, 47"	RBU47	Boxed	1
RE53†	Extreme Cross Bar Kit, 53"	RBU53	Boxed	1
RE60†	Extreme Cross Bar Kit, 60"	RBU60	Boxed	1
End Supports				
59970†	DFE End Support Kit, Door Frame Attachment	-	Boxed	1
59972 †	FPE End Support Kit, Fixed Point Attachment	-	Boxed	1
59976†	RBU End Support Kit, Raised Side Rail Attachment (Universal)	-	Boxed	1
R4000-1†	RBE End Support Kit, Flush Side Rail Attachment	-	Boxed	1
Lock Kits				
59315†	Lock Kit, (4 Pack)	59315	Boxed	1
59316†	Lock Kit, (8 Pack)	59316	Boxed	1

ROOF RACK FIT KITS **LAST CHANCE**

Part Number	Description	Substitute Part Number	Packaging	Master Carton
Direct Mount				
R7001†	Direct Mount Kit for Sheet Metal Surfaces	-	Boxed	1
R7002†	Direct Mount Kit for Fiberglass Surfaces	-	Boxed	1
Track Mount				
R7003†	Track Mount Adapter	-	Boxed	1
R7010†	Track Mount Kit for Sheet Metal Surfaces, 42"	-	Boxed	1
R7011†	Track Mount Kit for Sheet Metal Surfaces, 54"	-	Boxed	1
R7012†	Track Mount Kit for Fiberglass Surfaces, 60"	-	Boxed	1

RATCHET TIE DOWN **LAST CHANCE**

Part Number	Description	Substitute Part Number	Packaging	Master Carton
59305†	Aluminum Sport Handle Ratchet, 10 ft. Length, 1,800 lbs. Capacity	94828DT	Plastic Shroud	3

TRUCK BED RATCHET **LAST CHANCE**

Part Number	Description	Substitute Part Number	Packaging	Master Carton
95473DT†	Truck Bed Ratchet Strap, 9 ft., 400 lbs. capacity	-	Boxed	1

† = Available while supplies last



TRAILER JACKS

BULLDOG® and Fulton® are the unquestionable leaders in design, manufacturing and distribution of screw jacks for OEMs and consumers in the world. Safety and quality are at the fore front of every design, for every industry and every application. BULLDOG® leverages a Tough & Trusted™ heritage of quality and a well-earned reputation of reliability into becoming the preferred brand of industrial and agricultural OEMs and has helped to set the ISO standard and benchmark for jacks. Combining a best-in-class product selection, warranty and cycle life testing. Fulton® is the #1 choice for boaters, anglers, and marine trailer manufacturers. Fulton® leads the way for marine-focused high-quality performing products with innovative designs.

POWERED JACKS

4K Powered Jacks	J-3
3.5K Powered Jacks.....	J-4
2.5K Powered Jacks.....	J-5
Powered Fifth Wheel Landing Gear	J-5
Powered Marine Jacks	J-6
Velocity Series™ High Speed Jacks	J-21

MARINE AND RECREATIONAL JACKS

Powered Marine Jacks	J-6
XLT™ Series Marine Jacks.....	J-6
F2® Series Marine Jacks	J-7 - J-8

ROUND JACKS

Tubular Swivel Round Jacks.....	J-11
Weld-On Round Jacks.....	J-11 - J-13
A-Frame Round Jacks	J-12
Bolt-On Round Jacks.....	J-12
Pro Series™ Round Jacks.....	J-27 - J-28

SQUARE JACKS

5K Square Jacks.....	J-15 - J-16
8K Square Jacks.....	J-17
10K Square Jacks.....	J-18
12K Heavy Duty Jacks.....	J-19 - J-24

SPECIALTY JACKS

Landing Gear	J-5 / J-25
Ratchet Jacks	J-26
Farm Jacks.....	J-26
Rack and Gear Jacks.....	J-29

ACCESSORIES

Stabilizers and Drop Legs	J-30
Wheels and Footplates	J-31
Mounts and Pins.....	J-32
Cranks and Knobs.....	J-33 - J-34

DISCONTINUED PRODUCTS	J-35 - J-37
------------------------------------	--------------------

FEATURED

2-SPEED TANDEM LANDING GEAR

- AAR and TTMA rated (all values per pair):
 - 45,000 lbs. lifting capacity (@ 100 ft. lbs. input torque)
 - 90,000 lbs. static capacity
- Competitive cranking ratios:
 - Low speed gear 27.3 turns per in.
 - High speed gear 4.5 turns per in.
- High efficiency, double lead screw
- Heavy duty, self-leveling sand shoe
- Cross shaft sold separately
- Standard TTMA mount, mounted to inside of frame (bolt-on model, 500154)
- Heavy duty ban for added strength
- Ideal for horse, livestock and heavy duty trailers
- See page J-25 for additional information

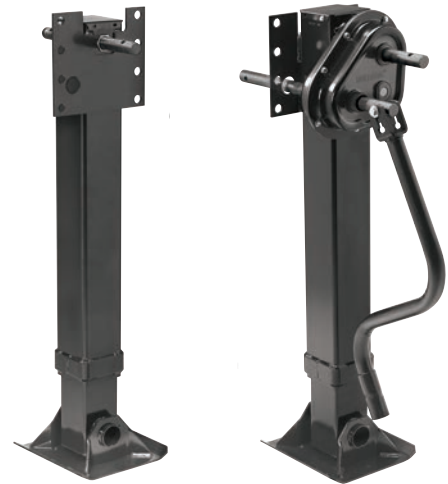

5K SQUARE JACKS

Compared to round jacks of similar capacities, the BULLDOG® 5,000 lbs. support capacity square jack dramatically improves side load strength while maintaining the economical benefits of lower capacity jacks. The extra side load capacity you need without the costs of increasing overall capacity.

- 12 gauge square tube is 70% stronger than 12 gauge round tube for more side load and support strength with the same lift capacity
- 4.62 in. outer tube overlap at full extension for additional side load strength
- Weather-resistant materials and coatings. Painted outer tubes, clear zinc inner tubes
- Proven, reliable mechanical elements provide dependable strength and long-lasting, durable performance
- Mounts included in this series of jacks
- See pages J-15 and J-16 for additional information



F2® MARINE AND RECREATIONAL JACKS

Fulton®, the industry leader for high performance marine jacks, is proud to introduce a revolution in trailer jack engineering. The F2®, designed for use with marine, recreational and utility trailers, continues the Fulton® heritage of innovation rethinking every feature and challenging industry conventions. The result is a re-engineered high quality product that will transform the industry.

- 35% faster lifting action than conventional jacks
- Ergonomic design - crank, release pin and integrated wheel wedge are made of strong, engineered plastic for a comfortable touch
- Stylish design - compliment your boat and customize your trailer's styling
- Twin track and wide track versions available
- Available in bolt-on and weld-on versions for up to 5 in. tongues
- Handle hold-up secures handle to jack tube when in stowed position
- See pages J-7 and J-8 for additional information



4K POWERED A-FRAME JACK

Tough and Trusted BULLDOG® presents a Powered Jack with all the capacity and features you want.

- Heavy duty 4,000 lbs. lift capacity
- Positions quickly with up to 22 in. of total travel
- Drop leg with spring loaded pull pin
- Makes setting up easier with a handy built-in level right where you need it most
- Deploys and hooks up easily at night with on-board LED courtesy light
- Works in case of power loss with emergency manual override capability, easily accessible from the top
- Manual override crank included
- Lasts for years with industry-leading BULLDOG® performance, known worldwide for unmatched strength, durability, and side load capacity
- Retains like-new appearance with corrosion-resistant surfaces
- 5-year limited warranty



500199



500200

4K

Part Number	Description	Lift Capacity (lbs.)	Travel (in.)	Retracted (in.)	Extended (in.)	Clearance (in.)	Packaging	Master Carton
500199	Black Cover, Includes Drop Leg	4,000	22.00	9.75	31.75	21.00	Litho Box	2
500200	White Cover, Includes Drop Leg	4,000	22.00	9.75	31.75	21.00	Litho Box	2
Replacement Parts								
500190	Drop Leg and Pin Kit						Litho Box	1
500193	Level Assembly and Screws						Poly Bag	25
500194	Manual Override Cover Kit						Poly Bag	25
500196	LED Light Assembly and Bulbs						Poly Bag	25
500203	Manual Override Crank						Poly Bag	24
500360	Black Cover with Mounting Screws						Boxed	1
500361	White Cover with Mounting Screws						Boxed	1
500362	Light Switch for #500187, #500188, #500199 and #500200						Poly Bag	25
500363	Extend/Retract Switch for #500187, #500188, #500199 and #500200						Poly Bag	25



On-Board LED Lighting



Single Axis Level



Spring Loaded Drop Leg Pull Pin



500187



500188

3.5K POWERED A-FRAME JACK

Tough and Trusted BULLDOG® presents a Powered Jack with all the capacity and features you want.

- Positions quickly with 14 in. of total travel
- 3,500 lbs. lift capacity
- Integrated gearbox and motor
- Drop leg
- Deploys and hooks up easily at night with on-board LED courtesy light, angled to illuminate coupler
- Works in case of power loss with emergency manual override capability, easily accessible from the top, crank included
- Manual override crank included
- Lasts for years with industry-leading BULLDOG® performance, known worldwide for unmatched strength, durability, and side load capacity
- Retains like-new appearance with corrosion-resistant surfaces
- 5-year limited warranty



3.5K

Part Number	Description	Lift Capacity (lbs.)	Travel (in.)	Retracted (in.)	Extended (in.)	Clearance (in.)	Packaging	Master Carton
500187	Black Cover, Includes Drop Leg	3,500	14.00	9.75	31.50	20.50	Litho Box	2
500188	White Cover, Includes Drop Leg	3,500	14.00	9.75	31.50	20.50	Litho Box	2
Replacement Parts								
500190	Drop Leg and Pin Kit						Litho Box	1
500201	Manual Override Cover						Poly Bag	25
500202	LED Light Assembly and Bulbs						Poly Bag	25
500203	Manual Override Crank						Poly Bag	24
500305	Black Cover with Mounting Screws						Boxed	1
500306	White Cover with Mounting Screws						Boxed	1
500362	Light Switch						Poly Bag	25
500363	Extend/Retract Switch						Poly Bag	25



LED Courtesy Light



3,500 lbs. Lift Capacity



Emergency Manual Override



500198

PRO SERIES™ 2.5K POWERED A-FRAME JACK

- Integrated circuit breaker
- 18 in. total travel
- Works in case of power loss with supplied manual override crank handle
- Gloss black painted outer tube and motor assembly, clear zinc inner tube
- 1-year limited warranty

Part Number	Description	Lift Capacity (lbs.)	Travel (in.)	Retracted (in.)	Extended (in.)	Packaging	Master Carton
500198	Jack, without Footplate	2,500	18.00	8.50	26.50	Litho Box	2
Replacement Parts							
500204	Drive Pin and Coupling					Poly Bag	1



500162

FIFTH WHEEL LANDING GEAR SYSTEM

- Traditional single drive system
- Heavy gauge 6 in. x 8 in. self-leveling foot plates with drain holes to prevent corrosion
- Spring loaded drop leg pin on 8,000 lbs. support capacity model
- Includes secondary gearbox
- 36 in. total travel
- Includes adjustable cross shaft
- Includes 4 mounting brackets and 4 sets of mounting hardware
- Motor, switch and harness must be obtained separately
- 5-year limited warranty



Part Number	Description	Support Capacity (lbs.)	Lift Capacity (lbs.)	Total Lift (in.)	Screw Travel (in.)	Packaging	Master Carton
500162	RV Landing Gear Assembly (Motor, Switch and Harness Must Be Obtained Separately)	8,000	4,000	36.00	18.00	Litho Box	1



500708

POWERED FIFTH WHEEL LANDING GEAR SYSTEM

- Includes: (2) RV landing legs with motors assembled, (1) control panel with two switches, (2) pull pin assemblies, (2) footplates with hardware, (4) mounting brackets with hardware and manual override socket adapter
- Improved motor stability
- Features the REESE® power drive, geared for high torque applications without sacrificing the operational speed of 9 in. of travel per minute
- Features an improved screw shaft
- Allows for independent control of each landing gear leg to assist in leveling the RV
- 6 in. x 8 in. self leveling foot plate
- Please note the motor cannot be inverted, however, the motor can rotationally be positioned in (4) 90-degree increments
- Manual override
- Spring loaded pull pin



Part Number	Description	Support Capacity (lbs.)	Lift Capacity (lbs.)	Total Lift (in.)	Screw Travel (in.)	Packaging	Master Carton
500708	RV Landing Gear Assembly	8,000	8,000	36.00	18.00	Boxed	1
Replacement Parts							
500359	Dual Output Motor					Boxed	1
500367	Drop Leg and Foot Plate					Boxed	1
500368	Control Switch					Boxed	1

141401



XLT™ POWERED MARINE JACK

- Patented spring-loaded drop leg pull pin positions quickly with 22 in. total travel
- Powered through 7-way or dedicated 12V DC battery
- Front and rear facing LED lights for low light conditions
- Corrosion resistant stainless steel internal ACME screw
- Easy to install - simply bolt to frame and hook up wiring
- Manual override using standard tools in case of power loss
- Includes mounting hardware for up to 5 in. high trailer tongues
- Premium Sharkskin™ finish:
 - Maximum corrosion resistance
 - Used in salt water environments and other demanding climate applications



Part Number	Description	Lift Capacity (lbs.)	Travel (in.)	Retracted (in.)	Extended (in.)	Clearance (in.)	Packaging	Master Carton
141401	Black Cover, Includes Drop Leg	2,500	22.00	9.75	31.75	21.00	Litho Box	2



Rear and Front LEDs



Spring Loaded Drop Leg Pull Pin



Fingertip Controls

141133



XLT™ MARINE AND RECREATIONAL JACK

- Patent pending TruTurn™ 360 system delivers best in class casting performance
- Raises and lowers 35% faster than the competition
- Patented inner and outer tube bushings provide a tight fit and lessen tube drag
- 20% more screw travel than conventional jacks
- Stylized handles with soft touch grips
- Grease fittings in key locations for easy lubrication
- Premium Sharkskin™ finish:
 - Maximum corrosion resistance
 - Used in salt water environments and other demanding climate applications



Part Number	Description	Lift Capacity (lbs.)	Handle Style	Travel (in.)	Retracted (in.)	Extended (in.)	Clearance (in.)	Packaging	Master Carton
141133	Bolt-On, Swing Away	1,500	Sidewind	12.00	15.00	27.00	15.50	Litho Box	2

Replacement Parts

500365	Pull Pin							Poly Bag	50
0933306S00	Service Kit, Includes: (2) Gears, (1) Pin, (1) Washer, (1) Spacer and (2) Flanged Bushings							Poly Bag	25

F2® MARINE AND RECREATIONAL JACKS

Fulton®, the industry leader for high performance marine jacks, is proud to introduce a revolution in trailer jack engineering. The F2®, designed for use with marine, recreational and utility trailers, continues the Fulton® heritage of innovation rethinking every feature and challenging industry conventions. The result is a re-engineered high quality product that will transform the industry. It's so strong and reliable that Fulton® is backing it with an unprecedented limited lifetime warranty.



- 35% faster lifting action than conventional jacks
- Ergonomic design - crank, release pin and integrated wheel wedge are made of strong, engineered plastic for a comfortable touch
- Stylish design - compliment your boat and customize your trailer's styling
- Twin track and wide track versions available
- Available in bolt-on and weld-on versions for up to 5 in. tongues
- Handle hold-up secures handle to jack tube when in stowed position
- Lifetime limited warranty



1413230134

F2® ADJUSTABLE SWIVEL JACK WITH FOOTPLATE

- Heavy duty articulating footplate - 7 in. diameter cast footplate provides superior stability
- Unique ball and socket connection between jack and footplate allows for whatever articulation is required to accommodate uneven surfaces

Part Number	Description	Lift Capacity (lbs.)	Handle Style	Screw Travel (in.)	Mount Travel (in.)	Pull Pin Diameter (in.)	Packaging	Master Carton
1413230134	Includes Handle Hold-Up Feature and Bolt-On Mounting Hardware for up to 5" Frames	2,000	Sidewind	10.00	13.00	9/16	Litho Box	2

F2® A-FRAME JACK AND COUPLER COMBINATION

- Fulton® expands the F2® family of trailer jacks with the adjustable height A-Frame jack and coupler combination



1413250334

44305F0317

Part Number	Description	Lift Capacity (lbs.)	Handle Style	Screw Travel (in.)	Packaging	Master Carton
1413250334	Adjustable Height A-Frame Jack, NOTE: Requires F2 Coupler	2,000	Sidewind	9.00	Bulk	25
44305F0317	Coupler, Class 4, 2-5/16" Ball, 10,000 lbs. Capacity Coupler				Bulk	50
Accessories						
500265	7" Twin Track Wheels, Includes Pull Pin Assembly (For use with Single Axle Trailers Only)				Poly Bag	25
500266	8" Wide Track Wheel, Includes Pull Pin Assembly (For use with Single Axle Trailers Only)				Poly Bag	25
500267	7" Round Articulating Footplate, Includes Pull Pin Assembly				Bulk	25
Replacement Parts						
500268	Mounting Hardware, Includes: Hex Head Bolt 3/8" - (3) 16 UNC and (3) Lock Washers 3/8"				Poly Bag	1
500134	Handle / Crank Kit, Includes: Handle Grip, Groove Pin and Mounting Hardware				Poly Bag	25
500129	Handle Holdup				Poly Bag	25
500135	Gearbox Cover Replacement Kit, Includes: (4) Mounting Screws				Poly Bag	25
500137	Bearing Replacement Kit, Includes: (2) Washers				Poly Bag	25
500314	Gear Kit, Includes: (1) Shim Washer 5/16", (1) Straight Pin 7/32" x 3/4", (1) Groove Pin 3/16" x 1-1/4", and (1) Washer 1/2" ID x 1-1/4" OD				Poly Bag	100

Twin Wheel US Patent D568,575 and Wide Wheel US Patent D570,072 and Handle US Patent D577,175



F2® WIDE TRACK JACK

- Includes handle hold-up feature, wheel wedge feature and bolt-on mounting hardware for 3 in. x 3 in. and 3 in. x 4 in. frames

Part Number	Description	Lift Capacity (lbs.)	Handle Style	Screw Travel (in.)	Mount Travel (in.)	Pull Pin Diameter (in.)	Packaging	Master Carton
1413040134	F2 Jack, Wide Track	1,600	Sidewind	10.00	8.00	9/16	Litho Box	2
1413140334	F2 Jack, Wide Track	1,600	Sidewind	10.00	8.00	9/16	Bulk	25

Twin Wheel US Patent D568,575 and Wide Wheel US Patent D570,072 and Handle US Patent D577,175

F2® TWIN TRACK JACK

- Includes handle hold-up feature, wheel wedge feature and bolt-on mounting hardware for 3 in. x 3 in. and 3 in. x 4 in. frames

Part Number	Description	Lift Capacity (lbs.)	Handle Style	Screw Travel (in.)	Mount Travel (in.)	Pull Pin Diameter (in.)	Packaging	Master Carton
1413020134	F2 Jack, Twin Track	1,600	Sidewind	10.00	8.00	9/16	Litho Box	2
1413120334	F2 Jack, Twin Track	1,600	Sidewind	10.00	8.00	9/16	Bulk	25

Twin Wheel US Patent D568,575 and Wide Wheel US Patent D570,072 and Handle US Patent D577,175



F2® JACK ACCESSORIES AND REPLACEMENT PARTS

Part Number	Description	Packaging	Master Carton
500134	Handle/Crank Kit, Includes Handle Grip, Groove Pin and Mounting Hardware	Poly Bag	25
500129	Handle Holdup	Poly Bag	25
500135	Gearbox Cover Replacement Kit, Includes (4) Mounting Screws	Poly Bag	25
500136	Pull Pin Replacement Kit, Includes Spring and Retaining Ring	Poly Bag	50
500137	Bearing Replacement Kit, Includes (2) Washers	Poly Bag	25
500276	4" x 5" Mount with Hardware	Poly Bag	25
500277	Weld-On Mounting Bracket and Hardware for 3" x 4" Pivot Housing	Poly Bag	25
500314	Gear Kit, Includes (1) Shim Washer 5/16", (1) Straight Pin 7/32" x 3/4", (1) Groove Pin 3/16" x 1-1/4" and (1) Washer 1/2" ID x 1-1/4" OD	Poly Bag	100
500320	XP to F2 Adapter Kit, For F2 Swivel Mount with 4" Frame	Clamshell	4
Twin Track Replacement Parts			
500130	Twin Track Wheel Replacement Kit, Includes (2) Wheels and Mounting Hardware	Boxed	100
500138	Twin Track Wheel Only	Boxed	25
500132	Twin Track Wheel Wedge Kit, Includes Mounting Hardware	Poly Bag	25
Wide Track Replacement Parts			
500131	Wide Track Wheel Replacement Kit, Includes Wheel and Mounting Hardware	Poly Bag	25
500133	Wide Track Wheel Wedge Kit, Includes Mounting Hardware	Poly Bag	25



XP15

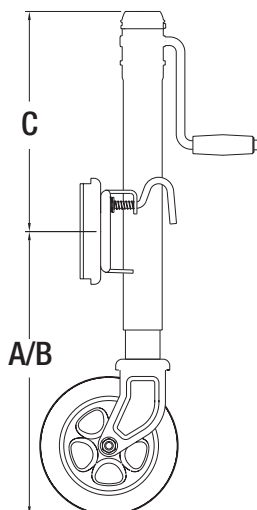

STANDARD ECONOMY MARINE AND RECREATIONAL JACKS

- Designed for use with marine and utility trailers, Fulton® brand tongue jacks are time- tested and application-proven
- Bolt-on versions include all necessary mounting hardware
- The Fulton® brand patented bolt-thru swivel mounts use 3-D formed heavy-gauge steel stampings and a proprietary bushing material for a mount with minimal deflection and maximum support
- Extensive choice of popular models, sidewind crank with round or square tubes
- Strong proprietary bushing materials
- Stable formed heavy-gauge steel construction
- Dependable design
- Lift capacity from 400 lbs. to 5,000 lbs.



• 600 hour salt spray rating per ASTM B117

BOLT-THRU SWIVEL JACKS

- Bolt-on
- 1/2 in. pull pin diameter
- Includes mounting hardware for up to 5 in. frames and handle and wheel (unassembled)

Part Number	Description	Lift Capacity (lbs.)	Handle Style	Travel (in.)	A Retracted (in.)	B Extended (in.)	C Clearance (in.)	Finish	Packaging	Master Carton
XP10 0101	6" Diameter Wheel	1,200	Sidewind	10.00	12.50	22.50	10.50	Z-Max 600	Litho Box	2
XP15 0101	8" Diameter Spoked Wheel	1,500	Sidewind	10.00	13.00	23.00	12.40	Z-Max 600	Litho Box	1
XP15L 0101	Additional 2" of Travel, 8" Diameter Spoked Wheel	1,500	Sidewind	12.00	13.00	25.00	14.40	Z-Max 600	Litho Box	2
XPD15L0101	Dual Wheel, Additional 2" of Travel, 6" Diameter Wheel	1,500	Sidewind	12.00	13.10	25.10	12.40	Z-Max 600	Litho Box	2

RETAINING RING SWIVEL JACKS

- Bolt-on
- 3/8 in. pull pin diameter
- Includes mounting hardware for up to 5 in. frames and handle and wheel (unassembled)

Part Number	Description	Lift Capacity (lbs.)	Handle Style	Travel (in.)	A Retracted (in.)	B Extended (in.)	C Clearance (in.)	Finish	Packaging	Master Carton
1410050149	Swiveling Trailer Stand, 6" Diameter Wheel, (1 Year Warranty)	400	-	-	14.50	-	4.50	Silver Powder Coat	Litho Box	2
TJ12000101	6" Diameter Wheel	1,200	Sidewind	10.00	12.70	22.70	11.40	Z-Max 600	Litho Box	2
EJ10000101	6" Diameter Wheel, (1 Year Warranty)	1,000	Sidewind	10.00	13.00	23.00	11.00	100 Hour Clear Zinc	Litho Box	1

SQUARE, FIXED MOUNT JACKS

- Bolt-on
- Includes mounting hardware for up to 6 in. frames and handle and wheel (unassembled)

Part Number	Description	Lift Capacity (lbs.)	Handle Style	Travel (in.)	A Retracted (in.)	B Extended (in.)	C Clearance (in.)	Finish	Packaging	Master Carton
HD25000101	3.8" x 7.5" Footplate, (Travel Includes Drop Leg)	2,500	Sidewind	28.00	7.00	35.50	19.25	Z-Max 600	Litho Box	2
HD50000101	6.0" x 8.0" Footplate, (Travel Includes Drop Leg)	5,000	Sidewind	28.00	6.50	35.00	18.50	Z-Max 600	Litho Box	1

MARINE AND RECREATIONAL JACK PARTS AND ACCESSORIES



500286

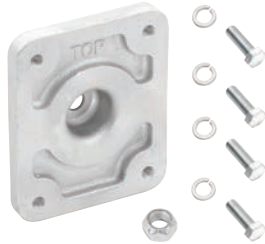

500320



0933301S00



6811S00



1400700340



1400750340

Part Number	Description	Packaging	Master Carton
Mounting Kits			
500286	Bolt-On Mounting Hardware Kit	Poly Bag	25
500349	Bolt on Mounting Kit for XP Series Jacks	Poly Bag	25
0933325S00	Mounting Hardware and Bushing for XP Bolt-Thru Swivel Mount	Poly Bag	25
Adapter Kits			
500320	Jack Accessory, XP to F2 Adapter Kit, For F2 Swivel Mount with 4" Frame	Clamshell	4
Handle Kits			
0933301S00	Includes (1) Handle Assembly with Plastic Handle Roller, (1) Groove Pin, and (1) Flanged Bushing TJ503/C, TJU503, PMJ53, TJ507/C, PMJ75, CS750, GR700/TJ712 , XP10/L/W/WC, XP100	Poly Bag	25
0933305S00	Includes (1) Handle Assembly with Plastic Handle Roller, (1) Groove Pin, and (1) Flanged Bushing TJ1055, TJ1057, TJ1222, TJ255, TJD125, TJ122F , XP15/L/W/WC, XP15L, HD2500	Poly Bag	25
Bevel Gear Kits			
0933302S00	Includes (2) Gears, (1) Groove Pin, (1) Pin, (1) Washer, and (1) Flanged Bushing TJ503 , XP10 (all 1,200 lbs. capacity)	Poly Bag	25
0933306S00	Includes (2) Gears, (1) Groove Pin, (1) Pin, (1) Washer, (1) Spacer, and (2) Flanged Bushings TJ1055, TJ1057, TJ1222, TJ1255, TJD125, TJ122F , XP15/L/W/WC, XPF15L, HD2500	Poly Bag	25
Plunger Pin Kit			
0933307S00	Includes (1) ½" Plunger Pin, (1) Plunger Pin Cap, (1) Washer, (1) Cotter Pin, and (1) Spring TJ1055, TJ1057, TJ1255, TJD125, TJ122F , XP15/L/W/WC, XPF15L XP10 (all 1,200 lbs. capacity)	Poly Bag	25
Wheel Repair Kit			
6811S00	All 6" Models Including TJ600T (Excluding TJD125, TJD103)	Poly Bag	25
0933323S00	All 8" Models	Poly Bag	25
Caps			
500325	End Cap for HD2500 Jack	Poly Bag	50
500322	End Cap for TJ1200 and EJ1000 Jacks	Poly Bag	100
500323	End Cap XP10 Jacks	Poly Bag	80
500324	End Cap for XP15 Jacks	Poly Bag	80

NOTE: RED part numbers indicate discontinued items

STANDARD ECONOMY ROUND JACK WHEEL AND FOOT OPTIONS

Part Number	Description	Packaging	Master Carton
1400700340	Removable Footplate, 2.10" Tall, Fits 2" Inner Tube, Includes Pull Pin Assembly, Clear Zinc Finish, 5,000 lbs. Capacity	Bulk	20
1400750340	Removable 6" Caster, Includes Pull Pin Assembly, Clear Zinc Finish, 1,200 lbs. Capacity	Bulk	8

ROUND JACKS

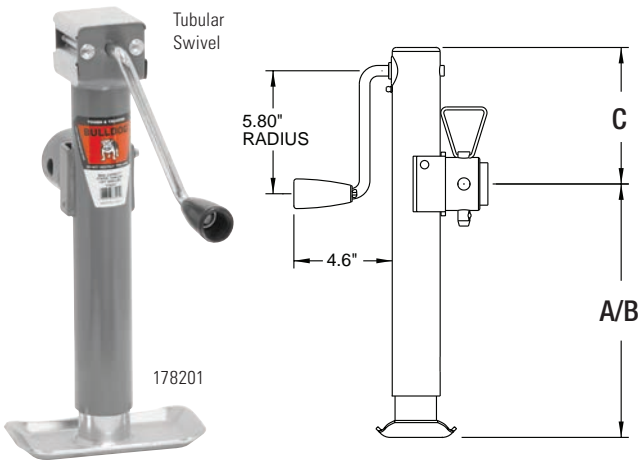

ROUND JACKS

- High-strength, heavy-duty design
- Unmatched strength, reliability, safety and value
- Precision fitted parts for extra stability
- A-Frame models listed have gray painted outer and inner tubes
- Most models have gray outer tube and zinc plated inner tube



THE CHOICE WHEN
APPLICATION REQUIRES
COMPLIANCE WITH
ASABE S485 STANDARDS

Travel and Clearance Diagram

A= Retracted

B= Extended

C= Clearance Height

WELD-ON TUBULAR SWIVEL ROUND JACKS

Part Number	Model Number	Description	Lift Capacity (lbs.)	Pin (in.)	Handle Style	Travel (in.)	A Retracted (in.)	B Extended (in.)	C Clearance (in.)	Packaging	Master Carton
158451 ◊	TWS 158 DTSF w/P&C	Includes Footplate and Male Mating Mount	2,000	9/16	Topwind	10.00	11.00	21.00	4.00	Bulk	150
158452 ◊	TWL 158 DTSF w/P&C	Includes Footplate and Male Mating Mount	2,000	9/16	Topwind	15.00	14.50	29.50	10.00	Bulk	100
150441	TWS 150 DTSFX w/P&C	Includes Footplate, Clear Zinc Finish	2,000	9/16	Topwind	10.00	11.00	21.00	4.00	Bulk	50
158488	TWL 150 DTSF w/P&C	Includes Footplate and Mating Mount, Clear Zinc Finish	2,000	9/16	Topwind	15.00	16.00	31.00	4.00	Bulk	50
158109	SWS 158 DTSF w/P&C	Includes Footplate and Male Mating Mount	2,000	9/16	Sidewind	10.00	10.80	20.80	6.40	Bulk	100
158151 ◊	SWL 158 DTSF w/P&C	Includes Footplate and Male Mating Mount	2,000	9/16	Sidewind	15.00	14.50	29.50	12.20	Bulk	100
1541150301	SWS 158 DTSF	No Foot or Mount	2,000	5/8	Sidewind	10.00	7.70	17.70	8.70	Bulk	50
1581510117	SWL 158 DTSP w/P&C	Includes Footplate and Male Mating Mount	2,000	9/16	Sidewind	15.00	14.50	29.50	12.20	Bulk	100
1581090301	N/A	Includes Footplate	2,000	5/8	Sidewind	10.00	10.80	20.80	6.30	Bulk	100
1501040301	TWL 150 DTSF w/P&C	Includes Footplate and Male Mating Mount, Clear Zinc Outer Tube and Inner Tube	3,000	5/8	Topwind	15.00	12.40	27.40	12.25	Bulk	50
610322	3 TMX-20-X	Includes Footplate, Clear Zinc Outer Tube and Inner Tube	3,000	5/8	Topwind	20.00	3.10	23.10	3.70	Bulk	50
178101 ◊	TWS 178 DTSF w/P&C	Includes Footplate and Male Mating Mount	5,000	9/16	Topwind	10.00	11.25	21.25	4.00	Bulk	50
178151	TWL 178 DTSF w/P&C	Includes Footplate and Male Mating Mount	5,000	9/16	Topwind	15.00	14.70	29.70	10.00	Bulk	50
178201 ◊	SWS 178 DTSF w/P&C	Includes Footplate and Male Mating Mount	5,000	5/8	Sidewind	10.00	10.40	20.40	6.40	Bulk	100
178203	SWL 178 DTSF w/P&C	Includes Footplate and Male Mating Mount	5,000	5/8	Sidewind	15.00	15.40	30.40	6.40	Bulk	100
198100	TWS 198 DTSM w/P&C	Includes Footplate and Female Mating Mount	7,000	5/8	Topwind	10.00	10.80	20.80	4.50	Bulk	25
198200	TWL 198 DTSM w/P&C	Includes Footplate and Female Mating Mount	7,000	5/8	Topwind	15.00	15.80	30.80	4.25	Bulk	25
198150 ◊	SWS 198 DTSM w/P&C	Includes Footplate and Female Mating Mount	7,000	5/8	Sidewind	10.00	11.00	21.00	6.40	Bulk	25
198250	SWL 198 DTSM w/P&C	Includes Footplate and Female Mating Mount	7,000	5/8	Sidewind	15.00	16.00	31.00	6.40	Bulk	25

◊ Denotes most popular

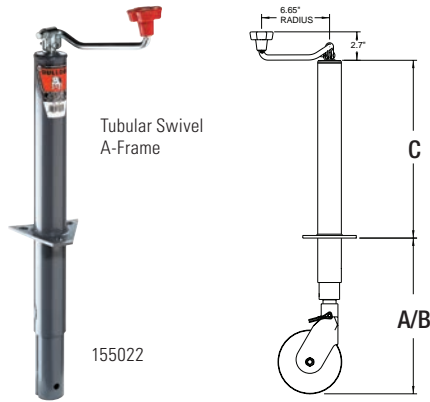

Travel and Clearance Diagram
A= Retracted
B= Extended
C= Clearance Height

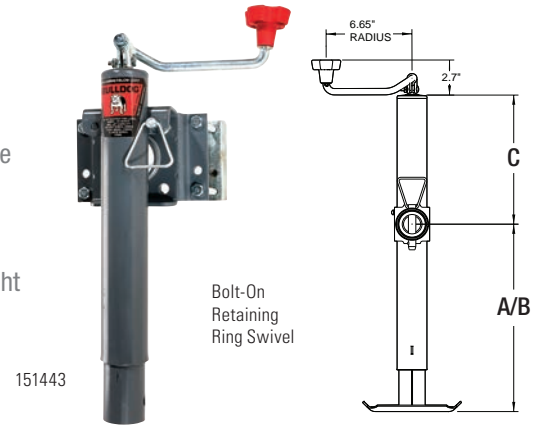

A-FRAME ROUND JACKS

Part Number	Model Number	Description	Lift Capacity (lbs.)	Handle Style	Travel (in.)	A Retracted (in.)	B Extended (in.)	C Clearance (in.)	Packaging	Master Carton
155022	TWL 155	Weld-On/Bolt-On Bracket	2,000	Topwind	15.00	8.80	23.80	12.20	Bulk	150
155028	TWL 155	Weld-On/Bolt-On Bracket, Clear Zinc Finish	2,000	Topwind	15.00	8.40	23.40	13.00	Bulk	50
155033	TWL 155X	Weld-On/Bolt-On Bracket	2,000	Topwind	15.00	5.40	20.40	16.00	Bulk	50
155100	N/A	7.5" Bracket to Ground Retracted, with Welded Disc Foot	2,000	Topwind	15.00	7.50	22.50	17.00	Bulk	50
155157	SWL 155X (RV)	External Gear Box, Handle to Front, Weld-On/Bolt-On Bracket	2,000	Sidewind	13.00	8.60	21.50	13.00	Bulk	150
1550100317	SWL 155 X	External Gear Box, Weld-On/Bolt-On Bracket	3,000	Sidewind	13.00	7.00	20.00	14.50	Bulk	150
1550101344	SWL 155 X	External Gear Box, Weld-On/Bolt-On Bracket, Clear Zinc Finish	3,000	Sidewind	13.00	7.00	20.00	14.50	Bulk	50
155032	TWL 155 HD	Weld-On/Bolt-On Bracket	5,000	Topwind	15.00	10.30	25.30	10.20	Bulk	100
1750290317	TWL 175	Weld-On/Bolt-On Bracket	5,000	Topwind	15.00	10.82	25.82	10.70	Bulk	50
1750290301	TWL 175	Weld-On/Bolt-On Bracket, Clear Zinc Finish	5,000	Topwind	15.00	10.82	25.82	10.70	Bulk	50
1700100317	SWL 175	Handle to Front, Weld-On/Bolt-On Bracket	5,000	Sidewind	15.00	8.60	23.60	12.75	Bulk	50
1700100301	SWL 175	Handle to Front, Weld-On/Bolt-On Bracket, Clear Zinc Finish	5,000	Sidewind	15.00	8.60	23.60	12.75	Bulk	50

BOLT-ON RETAINING RING SWIVEL ROUND JACKS

Part Number	Model Number	Description	Lift Capacity (lbs.)	Handle Style	Travel (in.)	A Retracted (in.)	B Extended (in.)	C Clearance (in.)	Packaging	Master Carton
151443	TWS 159 SX	Bracket Assembled with Mounting Hardware, 1/2" Diameter Plunger Pin, Without Base, Fits Tongue up to 3" x 4"	2,000	Topwind	10.00	11.00	21.00	4.00	Bulk	50

CENTERBOLT SWIVEL ROUND JACKS

Part Number	Model Number	Description	Lift Capacity (lbs.)	Handle Style	Travel (in.)	A Retracted (in.)	B Extended (in.)	C Clearance (in.)	Packaging	Master Carton
154102	SWS 154 DC	Centerbolt Swivel Jack	2,000	Sidewind	10.00	10.80	20.80	6.26	Bulk	50
154107	TWS 154 DCX	Includes 1/2" Diameter Plunger Pin and Footplate, Female Mating Mount Not Included	2,000	Topwind	10.00	11.00	21.00	4.00	Bulk	50
Mounts										
500349	Bolt-On Mounting Kit for Centerbolt Swivel Round Jacks								Poly Bag	25
500286	Bolt-On Mounting Hardware								Poly Bag	50
P9012-00	Weld-On Mounting Kit for Centerbolt Swivel Round Jacks								Poly Bag	25

ROUND JACKS

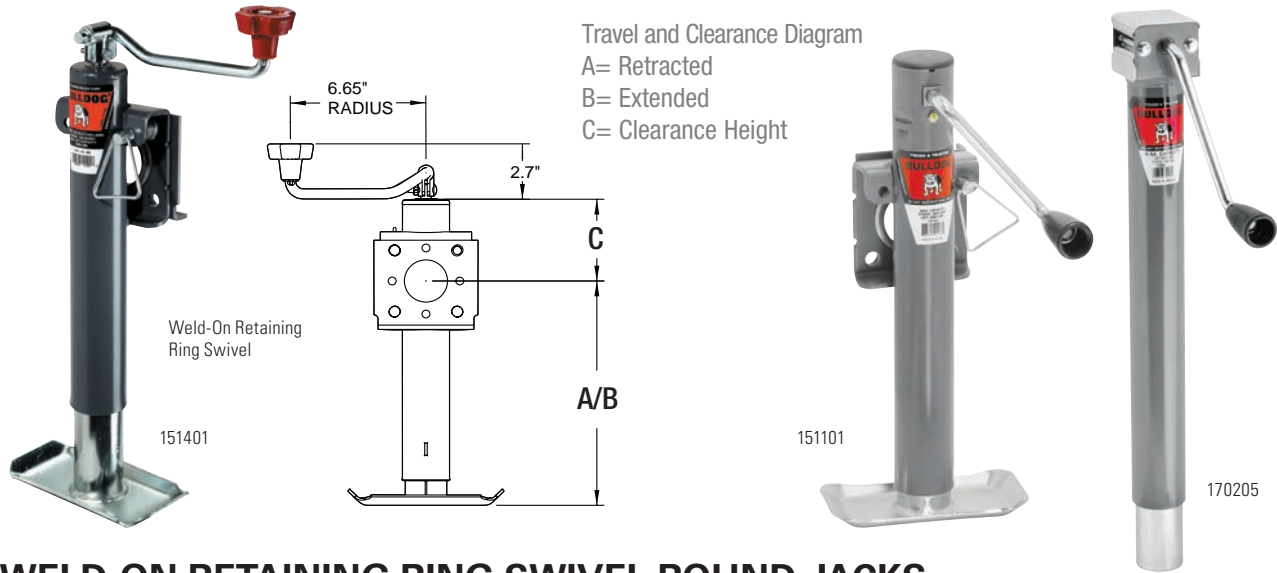

WELD-ON RETAINING RING SWIVEL ROUND JACKS

Part Number	Model Number	Description	Lift Capacity (lbs.)	Plunger Pin (in.)	Handle Style	Travel (in.)	A Retracted (in.)	B Extended (in.)	C Clearance (in.)	Packaging	Master Carton
151401 ◊	TWS 151 DS	L-Bend Swivel Bracket Assembled, Includes Footplate	2,000	1/2	Topwind	10.00	11.00	21.00	4.00	Bulk	150
151421	TWL 151 DS	L-Bend Swivel Bracket Assembled, Includes Footplate	2,000	1/2	Topwind	15.00	14.50	29.50	10.00	Bulk	100
151460	TWS 151 DS	Includes Footplate, Clear Zinc Finish, L-Bend Swivel Bracket Sold Separately	2,000	3/8	Topwind	10.00	11.00	21.00	4.00	Bulk	50
151464	TWL 151 DS	L-Bend Swivel Bracket Assembled, Includes Footplate	2,000	3/8	Topwind	15.00	16.00	31.00	4.00	Bulk	50
151101 ◊	SWS 151 DS	L-Bend Swivel Bracket Assembled, Includes Footplate	2,000	1/2	Sidewind	10.00	11.00	21.00	6.40	Bulk	100
151110	SWS 151 DSX	L-Bend Swivel Bracket Assembled, Includes Footplate	2,000	3/8	Sidewind	15.00	15.80	30.80	6.25	Bulk	50
151159	SWL 151 DS	L-Bend Swivel Bracket Assembled, Includes Footplate	2,000	1/2	Sidewind	15.00	14.50	29.50	12.20	Bulk	50
171401	TWS 171 DS	L-Bend Swivel Bracket Assembled, Includes Footplate	5,000	1/2	Topwind	10.00	11.25	21.25	4.00	Bulk	150
171412	TWL 171 DS	L-Bend Swivel Bracket Assembled, Includes Footplate	5,000	1/2	Topwind	15.00	14.50	29.50	10.00	Bulk	50

ROUND JACKS WITHOUT MOUNT

Part Number	Model Number	Description	Lift Capacity (lbs.)	Handle Style	Travel (in.)	A Retracted (in.)	B Extended (in.)	C Clearance (in.)	Packaging	Master Carton
150037	TWL 150 X	No Foot, No Mount, Painted Outer Tube, Zinc Inner Tube	2,000	Topwind	10.00	20.40	35.40	-	Bulk	50
150152	SWL 150	No Foot, No Mount, Painted Outer Tube, Zinc Inner Tube	2,000	Sidewind	15.00	26.60	41.60	-	Bulk	50
1500520317	SWL 150 X	No Foot, No Mount, Painted Outer Tube, Zinc Inner Tube	2,000	Sidewind	15.00	23.60	38.60	-	Bulk	50
150000	TWL 150	No Foot, No Mount, Painted Outer Tube, Zinc Inner Tube	2,000	Topwind	10.00	15.00	25.00	-	Bulk	50
1701480317	TWL 170	No Foot, No Mount, Painted Outer Tube, Zinc Inner Tube	5,000	Topwind	15.00	21.00	36.00	-	Bulk	50
170205	SWL 170	No Foot, No Mount, Painted Outer Tube, Zinc Inner Tube	5,000	Sidewind	15.00	19.20	34.20	-	Bulk	50

◊ Denotes most popular

ROUND JACK MOUNTING OPTIONS

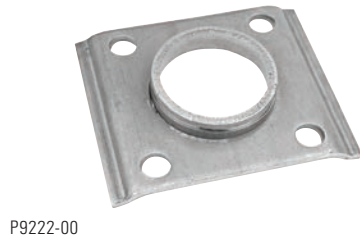

P9222-00



500105



500180

Part Number	Description	Packaging	Master Carton
P9222-00	Weld-On Retaining Ring Swivel Mount	Bulk	50
0050240300	Female, Weld-On, Tubular Swivel Mount, 5/8" Hole	Bulk	25
500239	Male, Weld-On, Tubular Swivel Mount, 9/16" Hole	Clamshell	8
500242	Weld-On, Swivel Bracket with L-Bend	Clamshell	10
0031350300	Weld-On, A-Frame Bottom Support Plate	Bulk	50

ROUND JACK HANDLE OPTIONS

Part Number	Description	Packaging	Master Carton
500256	Sidewind Crank Kit, Handle, 5-51/64" Radius Assembly and Gear for 2,000 lbs. Jacks	Clamshell	12
500105	Sidewind Crank Assembly for 170's with Black Knob	Clamshell	12
500180	Topwind Crank, 3-3/4" Radius with Red BULLDOG Knob for 750 - 5,000 lbs. Jacks	Clamshell	6
500148	Topwind Crank, 9" Radius with Black "Tear Drop" Knob for 7,000 lbs. Jacks	Clamshell	6
500171	Sidewind Crank Assembly for 190 Series, Black	Clamshell	6

ROUND JACK WHEEL / FOOT OPTIONS



017125



CE555 0301



0152790300

Part Number	Description	Packaging	Master Carton
017125	Removable Steel Caster. Reduces Overall Jack Capacity to 1,000 lbs.	Bulk	50
CE555 0101	Removable Polyolefin Caster. Reduces Overall Jack Capacity to 1,200 lbs.	Boxed	1
500244	Detachable Base, 2.1" Height, Fits 2" Tube	Clamshell	6
018098	Detachable Base, 6.2" Height, Fits 2" Tube	Bulk	50
500245	Removable 6" Caster with Pin. Fits Jacks with 2" Inner Tube	Clamshell	5
1400700340	Removable Footplate, 2.10" Tall, Fits 2" Inner Tube, Includes Pull Pin Assembly, Clear Zinc Finish, 5,000 lbs. Capacity	Bulk	20
1400750340	Removable 6" Caster, Includes Pull Pin Assembly, Clear Zinc Finish, 1,200 lbs. Capacity	Bulk	8

ROUND JACK TUBE MOUNTS

Part Number	Description	Packaging	Master Carton
0031550300	Female, Weld-On, 3/4" Pin for 190 Series	Bulk	25
0050050300	Male, Weld-On, 9/16" Pin	Poly Bag	50
0152710300	Female, Weld-On, 9/16" Pin, 2.5" O.D.	Poly Bag	50
0152730300	Male, Weld-On, 9/16" Pin for 150 and 170 Series	Poly Bag	50
0152790300	Male, Weld-On, 5/8" Pin, 2" O.D. for 170 Series	Bulk	50
0050240300	Female, Weld-On, 5/8" Pin for 190 Series	Bulk	25
7011800300	Male, Weld-On, 3/4" Pin for 190 Series	Bulk	10
005122	Female, Weld-On, 7/8" Pin for 182524 and 182374	Bulk	25
500315	Female, Weld-On, 5/8" Pin for 150, 170 and 190 Series	Poly Bag	25
PQM19-00	Male, Weld-On, 5/8" Pin, 2.5" O.D.	Bulk	25

5K SQUARE JACKS

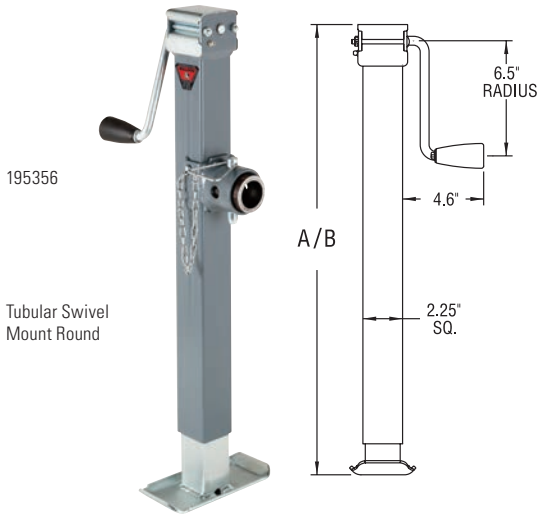

195356

Tubular Swivel
Mount Round

5K SQUARE JACKS

Compared to round jacks of similar capacities, the BULLDOG® 5,000 lbs. support capacity square jack dramatically improves side load strength while maintaining the economical benefits of lower capacity jacks. The extra side load capacity you need without the costs of increasing overall capacity.

- 12 gauge square tube is 70% stronger than 12 gauge round tube for more side load and support strength with the same lift capacity
- 4.6 in. outer tube overlap at full extension for additional side load strength
- Weather-resistant materials and coatings. Painted outer tubes, clear zinc inner tubes
- Proven, reliable mechanical elements provide dependable strength and long-lasting, durable performance
- Mounts included in this series of jacks



THE CHOICE WHEN
APPLICATION REQUIRES
COMPLIANCE WITH
ASABE S485 STANDARDS

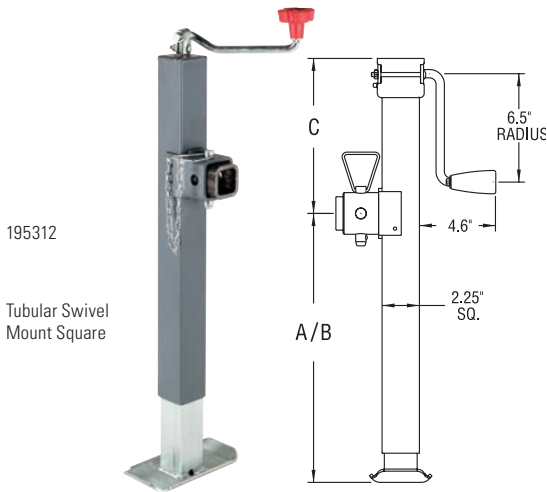

195312

Tubular Swivel
Mount Square

5K

Travel and Clearance Diagram

A= Retracted

B= Extended

C= Clearance Height

5K ROUND TUBULAR SWIVEL SQUARE JACKS

- Fixed leg with base with tubular swivel mount
- Includes male mating mount, pin and chain

Part Number	Model Number	Support Capacity (lbs.)	Lift Capacity (lbs.)	Handle Style	Travel (in.)	A Retracted (in.)	B Extended (in.)	C Clearance (in.)	Packaging	Master Carton
195306 ◊	TWL 195 DTSFQ	5,000	3,000	Topwind	15.00	15.20	30.20	7.00	Bulk	25
195356 ◊	SWL 195 DTSFQ w/P&C	5,000	3,000	Sidewind	15.00	15.10	30.10	9.25	Bulk	25

5K SQUARE TUBULAR SWIVEL SQUARE JACKS

- Fixed leg with base with square mount welded to outer tube
- Includes male mating mount, pin and chain

Part Number	Model Number	Support Capacity (lbs.)	Lift Capacity (lbs.)	Handle Style	Travel (in.)	A Retracted (in.)	B Extended (in.)	C Clearance (in.)	Packaging	Master Carton
195312 ◊	TWL 195 DTSXFQ w/P&C	5,000	3,000	Topwind	15.00	15.20	30.20	7.00	Bulk	25
195362	SWL 195 DTSXFQ w/P&C	5,000	3,000	Sidewind	15.00	15.10	30.10	9.25	Bulk	25

◊ Denotes most popular

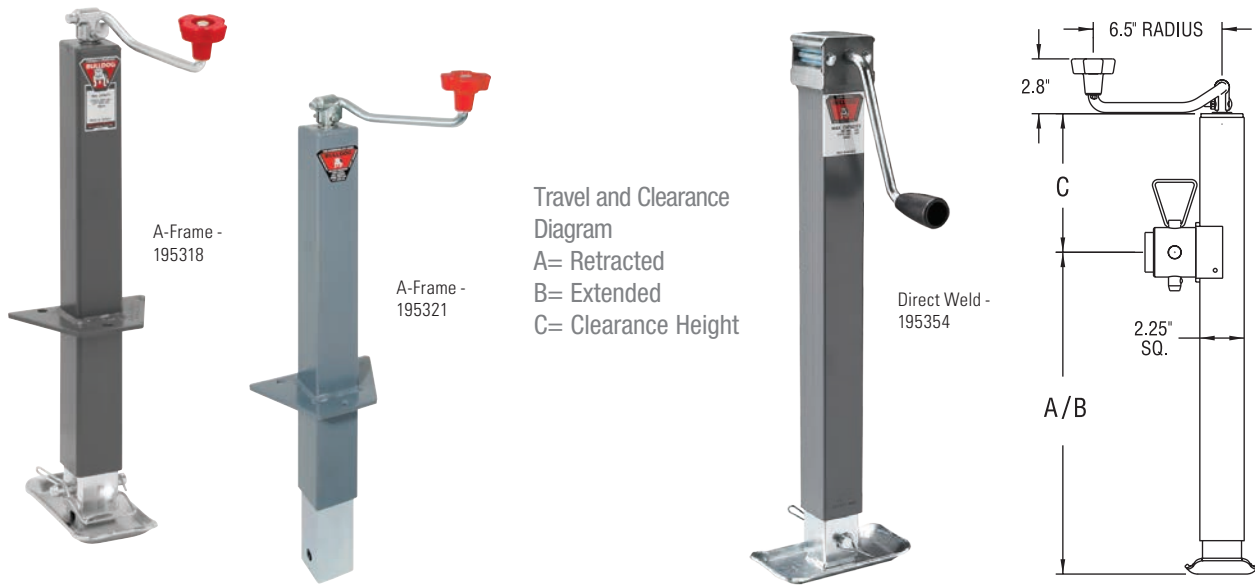

Travel and Clearance Diagram
 A= Retracted
 B= Extended
 C= Clearance Height

5K A-FRAME SQUARE JACKS

Part Number	Model Number	Description	Support Capacity (lbs.)	Lift Capacity (lbs.)	Handle Style	Travel (in.)	A Retracted (in.)	B Extended (in.)	C Clearance (in.)	Packaging	Master Carton
195318	TWL 195 DL-DFXQ	Drop Leg with Base, Drop Leg Offers 13.50" Additional Adjustment	5,000	3,000	Topwind	15.00	7.90	36.50	14.70	Bulk	25
195321 ◊	TWL 195 FL-FXQ	Fixed Leg Less Base	5,000	3,000	Topwind	15.00	7.40	22.40	14.70	Bulk	25

5K DIRECT WELD SQUARE JACKS

Part Number	Model Number	Description	Support Capacity (lbs.)	Lift Capacity (lbs.)	Handle Style	Travel (in.)	A Retracted (in.)	B Extended (in.)	C Clearance (in.)	Packaging	Master Carton
195301 ◊	TWL 195 DQ	Fixed Leg with Base	5,000	3,000	Topwind	15.00	22.20	37.20	-	Bulk	25
195304 ◊	TWL 195 DL-DXQ	Drop Leg with Base, Drop Leg Offers 13.50" Additional Adjustment	5,000	3,000	Topwind	15.00	22.60	51.20	-	Bulk	25
195319	TWL 195 FL-BXQ	Fixed leg with Caster Base	5,000	3,000	Topwind	15.00	22.30	37.30	-	Bulk	25
195320	TWL 195 FL-XQ	Fixed Leg Less Base	5,000	3,000	Topwind	15.00	22.10	37.10	-	Bulk	25
195351	SWL 195 DQ	Fixed Leg with Base	5,000	3,000	Sidewind	10.00	17.70	27.70	-	Bulk	25
195352	SWL 195 DQ	Fixed Leg with Base	5,000	3,000	Sidewind	15.00	24.40	39.40	-	Bulk	25
195354 ◊	SWL 195 DL-DXQ	Drop Leg with Base, Drop Leg Offers 13.50" Additional Adjustment	5,000	3,000	Sidewind	15.00	25.50	54.10	-	Bulk	25
195368	SWL 195 FL-XQ	Fixed leg with Caster Base	5,000	3,000	Sidewind	15.00	24.40	39.40	-	Bulk	25
195369	SWL 195 FL-XQ	Fixed Leg Less Base	5,000	3,000	Sidewind	15.00	24.20	39.20	-	Bulk	25

◊ Denotes most popular

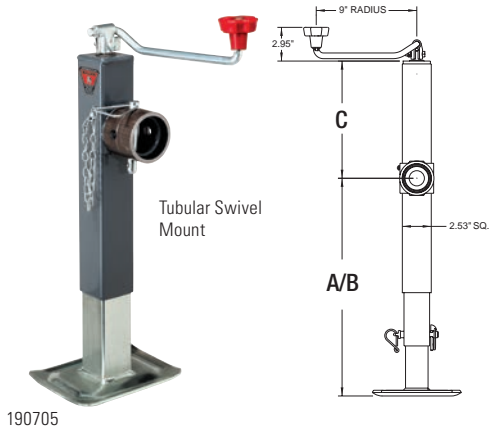

190705

8K

8K SQUARE JACKS

The BULLDOG® 8,000 lbs. support capacity square jack serves the agricultural, industrial, construction, horse/livestock trailer, and utility/cargo trailer markets. The compact design of these jacks makes them ideal for tight-fitting applications where 3 in. and 4 in. square tube jacks are too large.

- Use the painted outer tube as the final finish or primer
- Zinc-plated inner tube and drop leg
- 4.7 in. outer / inner tube overlap - results in optimal side load performance
- 5/8 in. screw stem - provides insurance against screw stem twisting off
- Patented screw nut stop - prevents screw and/or nut damage when jack is fully extended
- Topwind models - bushing in top cap, eagle claw grip
- Sidewind models - 1/4 in. cross pin connects gear train to screw stem - guards against shearing jack pin sidewind models - 1:1.33 gear ratio



Travel and Clearance Diagram

A= Retracted

B= Extended

C= Clearance Height

8K TUBULAR SWIVEL SQUARE JACKS

- Includes mating mount, pin and chain, (mating mount not included on 190724 and 190789, use 0031550300)

Part Number	Model Number	Description	Support Capacity (lbs.)	Lift Capacity (lbs.)	Handle Style	Travel (in.)	A Retracted (in.)	B Extended (in.)	C Clearance (in.)	Packaging	Master Carton
190705 ◊	TWS 190 FL-B TSMQ w/P&C	Fixed Leg with Heavy-Duty Base	8,000	5,000	Topwind	10.00	11.41	21.41	4.25	Bulk	25
190706	TWL 190 FL-B TSMQ w/P&C	Fixed Leg with Heavy-Duty Base	8,000	5,000	Topwind	15.00	12.16	27.16	10.25	Bulk	25
190708	TWL 190 DL-B TSMQ w/P&C	Drop Leg with Heavy-Duty Base, Drop Leg Offers 13.50" Additional Adjustment	8,000	5,000	Topwind	15.00	12.66	41.16	10.25	Bulk	25
190724	TWL 190 FL-DTS BQ	Fixed Leg with Heavy-Duty Base, without Mating Mount	8,000	5,000	Topwind	15.00	15.10	30.10	7.00	Bulk	25
190756 ◊	SWL 190 FL-B TSMQ w/P&C	Fixed Leg with Heavy-Duty Base	8,000	5,000	Sidewind	15.00	12.16	27.16	12.40	Bulk	25
190758	SWL 190 DL-B TSMQ w/P&C	Drop Leg with Heavy-Duty Base, Drop Leg Offers 13.50" Additional Adjustment	8,000	5,000	Sidewind	15.00	12.66	41.16	12.40	Bulk	25

8K DIRECT WELD SQUARE JACKS

- Drop leg with heavy-duty base offers 13.50 in. of additional adjustment

Part Number	Model Number	Support Capacity (lbs.)	Lift Capacity (lbs.)	Handle Style	Travel (in.)	A Retracted (in.)	B Extended (in.)	C Clearance (in.)	Packaging	Master Carton
190704 ◊	TWL 190 DL-BQ	8,000	5,000	Topwind	15.00	22.66	51.41	-	Bulk	25
190754 ◊	SWL 190 DL-BQ	8,000	5,000	Sidewind	15.00	25.06	53.56	-	Bulk	25
1907540176	SWL 190 DL-BQ	8,000	5,000	Sidewind	15.00	25.06	53.56	-	Boxed	20

◊ Denotes most popular

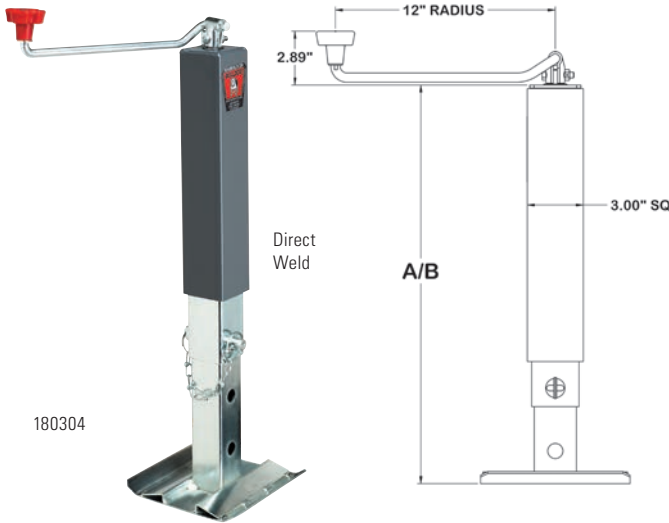

10K

10K SQUARE JACKS

The BULLDOG® 10,000 lbs. support capacity square jacks “fills the gap” between 8,000 lbs. and 12,000 lbs. square jack product offerings. If the existing 8,000 lbs. support capacity square jacks are too small or the 12,000 lbs. support capacity square jacks are too large, look no further – your application and pricing requirements have been met!

- Highest quality and best performing jack available in the marketplace today, a total balance between capacity, speed and effort
- Heavy-gauge 3 in. square tubing allows for direct weld mounting wherever the application allows – no burn through
- Use the painted outer tube as the final finish or primer
- Zinc-plated inner tube and drop leg
- Heavy-duty base, with reinforcement ribs, zero water retention
- Precision manufactured for long term reliability and smooth, easy cranking
- Grease zerk for easy lubrication as needed
- Oil-impregnated bushing for improved bearing and gear life
- Direct weld to outer tube is standard
- Sidewind models - 1:1.86 gear ratio



Travel and Clearance Diagram
 A= Retracted
 B= Extended
 C= Clearance Height

10K DIRECT WELD SQUARE JACKS

- Drop leg with heavy-duty base offers up to 13.50 in. of additional adjustment

Part Number	Model Number	Drop Leg Adjustment (in.)	Support Capacity (lbs.)	Lift Capacity (lbs.)	Handle Style	Travel (in.)	A Retracted (in.)	B Extended (in.)	Packaging	Master Carton
180304 ◊	TWS 180 DL-BQ	10.12	10,000	7,200	Topwind	10.00	18.18	38.31	Bulk	25
180354	TWL 180 DL-BQ	13.50	10,000	7,200	Topwind	15.00	22.93	51.43	Bulk	25
180405	SWS 180 DL-BQ	10.12	10,000	7,200	Sidewind	10.00	19.93	40.05	Bulk	25
180455 ◊	SWL 180 DL-BQ	13.50	10,000	7,200	Sidewind	15.00	25.67	54.17	Bulk	25

10K SQUARE TUBULAR SWIVEL SQUARE JACKS

- Fixed leg with base
- Square mount welded to outer tube
- Includes male mating mount, pin and chain

Part Number	Model Number	Support Capacity (lbs.)	Lift Capacity (lbs.)	Handle Style	Travel (in.)	A Retracted (in.)	B Extended (in.)	C Clearance (in.)	Packaging	Master Carton
180587	SWL 180 FT-BTSXQ	10,000	7,200	Sidewind	15.00	12.00	27.00	12.80	Bulk	25

◊ Denotes most popular

12K HEAVY DUTY SQUARE JACKS

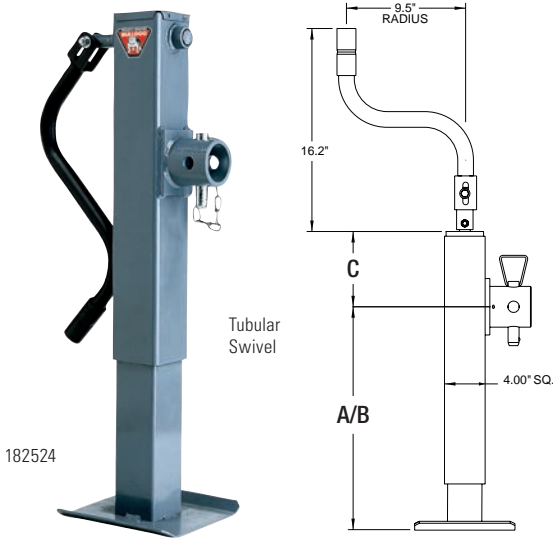

12K HEAVY DUTY SQUARE JACKS

Strong, durable, and sturdy, the BULLDOG® 12,000 lbs. support capacity square jack is the BIG reason why BULLDOG® has carried the load in agricultural, construction, heavy-duty utility, and horse/livestock trailer industries since 1923. All BULLDOG® 4 in. square jacks are rated for 12,000 lbs. support capacity and 10,000 lbs. lift capacity. The strength of the product, plus the wide variety of styles, makes this jack the best choice in its product class.

- 4 in. square tubing, 7-gauge superior alloy steel
- Painted outer tube, inner tube, and drop leg
- Drop leg option with 5 positioning holes
- Easy-access gear box with grease fitting for routine maintenance
- Spring return drop leg or non-spring return drop leg
- 12.5 in. screw travel, 13.5 in. of additional adjustment with drop leg
- Front facing drop leg plunger pin or side facing drop leg plunger pin
- Painted (with or without labels) or powder paint optional
- Sidewind models - 1:1.5 gear ratio
- Direct weld to outer tube is standard
- Sidewind models - 1:1.86 gear ratio



THE CHOICE WHEN APPLICATION REQUIRES COMPLIANCE WITH ASABE S485 STANDARDS

12K

12K DIRECT WELD, SPRING RETURN HEAVY DUTY SQUARE JACKS

- Drop leg with standard disc foot offers 13.50 in. of additional adjustment

Part Number	Model Number	Description	Support Capacity (lbs.)	Lift Capacity (lbs.)	Handle Style	Travel (in.)	A Retracted (in.)	B Extended (in.)	C Clearance (in.)	Packaging	Master Carton
182800 ◊	SWQ 180 DL-B-SR	Drop Leg Pull Pin to the SIDE, Crank Sold Separately	12,000	10,000	Sidewind	12.50	27.40	53.60	-	Bulk	25
182804	SWQ 180 DL-BC-SR	Drop Leg Pull Pin to the SIDE, Includes Crank	12,000	10,000	Sidewind	12.50	27.40	53.60	-	Bulk	20
182805	SWQ 180 DL-BX RH	Drop Leg Pull Pin to the SIDE, Crank Sold Separately Companion Jack to 182800, 182802, and 182804	12,000	10,000	Sidewind	12.50	27.40	53.50	-	Bulk	25
182815 ◊	SWQ 180 DL-BX	Drop Leg Pull Pin to the FRONT, Crank Sold Separately	12,000	10,000	Sidewind	12.50	28.60	54.60	-	Bulk	25

12KTUBULAR SWIVEL, NON-SPRING RETURN HEAVY DUTY SQUARE JACK

- Fixed leg with standard disc foot
- Includes crank
- 3.25 in. diameter tube mount with pin and chain
- Mating mount not included, (use 005122)

Part Number	Model Number	Support Capacity (lbs.)	Lift Capacity (lbs.)	Handle Style	Travel (in.)	A Retracted (in.)	B Extended (in.)	C Clearance (in.)	Packaging	Master Carton
182524	SWQ 180 TS-FL-BCX	12,000	10,000	Sidewind	12.50	17.00	29.60	10.10	Bulk	20

◊ Denotes most popular

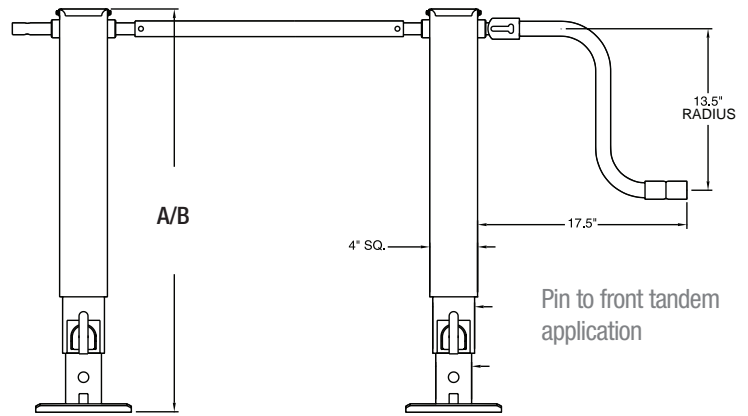
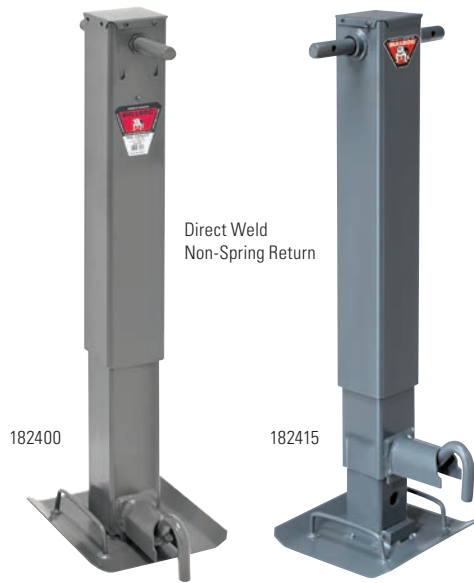

Travel and Clearance Diagram
 A= Retracted
 B= Extended
 C= Clearance Height

12K DIRECT WELD, NON-SPRING RETURN HEAVY DUTY SQUARE JACKS

- Drop leg with standard disc foot offers 13.50 in. of additional adjustment, (182500 has fixed leg)

Part Number	Model Number	Description	Support Capacity (lbs.)	Lift Capacity (lbs.)	Handle Style	Travel (in.)	A Retracted (in.)	B Extended (in.)	C Clearance (in.)	Packaging	Master Carton
182300	TWQ 180 DL-B	Crank Sold Separately	12,000	10,000	Topwind	12.50	23.40	49.40	-	Bulk	25
182304 ◊	TWQ 180 DL-BC	Crank Included	12,000	10,000	Topwind	12.50	23.40	49.40	-	Bulk	25
182400 ◊	SWQ 180 DL-B	Drop Leg Pull Pin to the SIDE, Crank Sold Separately	12,000	10,000	Sidewind	12.50	27.40	53.30	-	Bulk	25
182404	SWQ 180 DL-BC	Drop Leg Pull Pin to the SIDE, Crank Included	12,000	10,000	Sidewind	12.50	27.40	53.30	-	Bulk	20
182411	SWQ 180 DL-B	Drop Leg Pull Pin to the SIDE, Crank Sold Separately, Companion Jack to 182400 and 182404	12,000	10,000	Sidewind	12.50	27.40	53.50	-	Bulk	25
182415 ◊	SWQ 180 DL-BX	Drop Leg Pull Pin to the FRONT, Crank Sold Separately	12,000	10,000	Sidewind	12.50	28.60	54.60	-	Bulk	25
182500	SWQ 180 FL-B	Fixed Leg Jack with Standard Disc Foot, Crank Sold Separately	12,000	10,000	Sidewind	12.50	27.00	39.50	-	Bulk	25

12K SUPPORT CAPACITY JACK ACCESSORIES

Part Number	Description	Packaging	Master Carton
015181	Sidewind Crank Assembly with 13.50"Radius, Vertical Clevis, Mounting Hardware Included, Extends 17.50" from the Jack, Black Primed Finish	Bulk	400
800102	Sidewind Crank Assembly with 13.50"Radius, Horizontal Clevis, Mounting Hardware Included, Extends 17.50" from the Jack, Black Primed Finish	Bulk	100
800075	Topwind Crank Assembly with 9.50" Radius, Vertical Clevis, Mounting Hardware Included, Extends 15.50" from the Top of the Jack, Black Primed Finish	Bulk	400
800090	Sidewind Crank Assembly with 13.50" Radius, Horizontal Clevis, Mounting Hardware Included, Extends 17.50" from the Jack, Black Primed Finish	Bulk	25
701466	Removable Sidewind Crank with 13.5" Offset Radius, All Zinc-Plated Crank, Dual Handle Grips for Cranking and Shifting, For use with OEM Supplied Outboard Bushing or May be Attached Directly on Jack Gear box, Needs 012378 adapter with traditional Gear Box	Poly Bag	10
CS730300	Cross Shaft Extension Tube 72.75" to Connect Jacks in Tandem Application	Bulk	25
500312	Handle Clip	Bulk	100

◊ Denotes most popular



VELOCITY SERIES™ HIGH SPEED JACKS

- Fast, Powerful, Easy to Install
- OEM and Aftermarket Industrial, Horse and Livestock, and RV Applications
- Mounts without welding and requires no hydraulic oil, hoses, or pumps
- Fully Powered – 12,000 lbs. capacity per leg with Proprietary high-speed system
- 24 in. total travel
- Approximate travel speed and current draw
 - 31 in. per minute at no load, 15 amps
 - 30 in. per minute at 4,000 lbs., 40 amps
 - 26 in. per minute at 8,000 lbs., 65 amps
 - 21 in. per minute at 12,000 lbs., 100 amps
- Includes wired remote
- Resists corrosion with premium powder coat finish
- Optional wireless controller available (P/N 500527)
- Manual override in case of power loss
- 5-year limited warranty



12K

185400
185402



Part Number	Description	Lift Capacity (lbs.)	Packaging	Master Carton
185400	Velocity Series High Speed Jack (Includes Single Remote)	12,000	Boxed	6
185402	Velocity Series High Speed Jack (Remote Not Included)	12,000	Boxed	6
Replacement Parts				
500374	Foot Plate for Velocity Series Jack		Boxed	1
500375	Cover Kit for Velocity Series Jack		Boxed	6
500376	Contact Kit for Velocity Series Jack		Boxed	25
Accessories				
500527	Wireless Controller, 3-Pin for Velocity Series Jack		Clamshell	10
500372	Single Remote for Velocity Series Jack		Boxed	1
500379	Tandem Switch for Velocity Series Jack		Boxed	25
500380	3-Pin Connector for Velocity Series Jack		Poly Bag	50
500382	Single Switch for Velocity Series Jack		Bulk	10
500386	Single Remote for Velocity Series Jack		Poly Bag	25
500389	Adapter Kit for Velocity Series Jack		Boxed	25

500527



Wireless Controller, 3-Pin

500386



Single Remote

500379



Tandem Switch



1824200100

POWERED DRIVE KITS

- Designed for use with BULLDOG® 12,000 lbs. and Twin Cam™ jacks
- Lifts 50% more than competition
 - Lifts 3 in. per minute at typical working loads
 - Can be manually cranked in the event of power loss
- State of the art 12VDC electric motor
 - Quiet operation - 50% quieter than competitive units
 - Efficient use of electrical power - 60% more efficient than competitive units
 - Permanently lubricated to provide years of maintenance free use
- Custom designed wiring harness and rocker switch enclosed in a weather proof box
 - Utilizes a 25 amp circuit breaker with push button reset feature
- Can be used in both single and tandem jack applications Kit includes all necessary components for ease of installation
 - Powered drive assembly
 - Torque stop tube with energy absorption device
 - Terminal box, wiring harness and switch box
 - Hex coupling (not shown, required when using in a tandem jack application)
 - Weather resistant cover (not shown)

12K



1824200100

Part Number	Description	Lift Capacity (lbs.)	Packaging	Master Carton
1824200100	Electric Powered Kit	7,250	Boxed	2
1824180100	Electric Powered Kit, Only Compatible with 2-Speed Square BULLDOG Planetary Jacks	7,250	Boxed	1
Replacement Parts				
500370	Powered Single Speed Drive Motor for 1824200100 Only		Bulk	10



1824180100

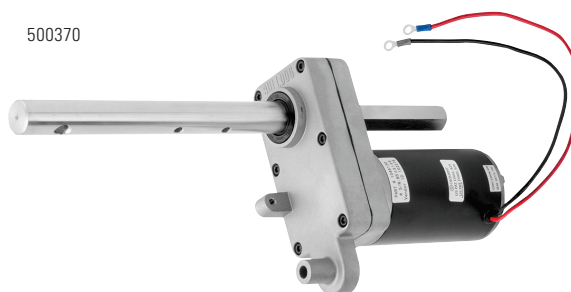

500370



TWIN CAM™ DROP LEG JACK

The industry's strongest drop leg jack. The BULLDOG® Twin Cam™ features a convenient, enclosed pin mechanism with "twin cam" action that will quickly make this heavy duty, drop leg jack the industry standard.

Twin Cam™ Drop Leg Mechanism:

- The BULLDOG® Twin Cam™ Drop Leg mechanism allows an increase in the vertical static capacity by using two 3/4 in. pins to transfer forces between the drop leg and inner tube of the jack
- The unique Twin Cam™ drop leg mechanism actuates the drop leg pins in both directions, giving the operator full control over engagement and disengagement of the drop leg pins
- The design does not rely on spring pressure alone to keep the pins in the locked position
- Patent pending
- The enclosed Twin Cam™ drop leg mechanism keeps dirt and debris from interfering with the engagement of the drop leg pins
- The Twin Cam™ drop leg mechanism maintains tighter alignment between the drop leg tube and inner tube by having engagement on both sides of the drop leg tube

Two-Speed Model (also includes):

- Convenient cranking ratios allow for fast operation under a wide range of loading conditions. Drop leg provides quick adjustment
- High speed cranking ratio of 9 turns per in. is convenient for loads up to 12,500 lbs.
- Low speed ratio of 29.5 turns per inch allows lifting loads up to 25,000 lbs.

Features:

- Easy access grease fittings allow for lubrication of internal jack gears and jack screw/nut
- Patented screw stop prevents screw and/or nut damage when the jack is fully extended, keeping the screw in good condition for maximum screw/nut cycle life
- Patented assembly design makes the gears, jack screw/nut, and other internal components easily serviceable
- 12.5 in. of screw travel
- Drop Leg features 5 positions with 13.5 in. of adjustment
- 10 in. x 10 in. heavy gauge steel foot plate
- Heavy duty 1 in. diameter steel input shaft
- Spring return and non-spring return drop legs available
- 10 in. x 10 in. heavy gauge steel foot plate
- Heavy duty 1 in. diameter steel input shaft
- Spring return and non-spring return drop legs available

Optional Accessory:

- Compatible with BULLDOG® Powered Drive electric motor system (reduces lift capacity to 7,500 lbs.)

† = Available while supplies last

182700†
Non
Spring
Return



183750†
Spring
Return



Travel and
Clearance
Diagram
A= Retracted
B= Extended

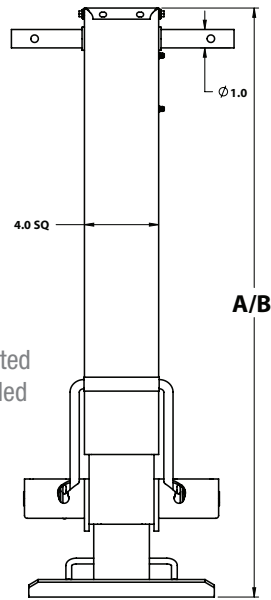

Configurations	Part Number	Static Capacity (lbs.)	Lift Capacity (lbs.)
1 Single-Speed Jack	182700† or 182701†	25,000	12,500
Pair of Single-Speed Jacks in Tandem	(2) 182700† or (2) 182701†	50,000	12,500
1 Two-Speed Jack	183749† or 183750†	25,000	25,000
Two-Speed and Single-Speed Jack in Tandem	182700† and 183749† or 182701† and 183750†	50,000	45,000

Part Number	Description	Handle Style	Screw Travel (in.)	Drop Leg Travel (in.)	A Retracted (in.)	B Extended (in.)	Packaging	Master Carton
182700†	Twin Cam Drop Leg, Non Spring Return, Crank Sold Separately	Sidewind	12.50	13.50	27.50	53.50	Bulk	20
182701†	Twin Cam Drop Leg, Spring Return, Crank Sold Separately	Sidewind	12.50	13.50	28.50	54.50	Bulk	20
183749†	Twin Cam Drop Leg, Non Spring Return, Crank Sold Separately	Sidewind Two-Speed	12.50	13.50	28.50	54.50	Bulk	10
183750†	Twin Cam Drop Leg, Spring Return, Crank Sold Separately	Sidewind Two-Speed	12.50	13.50	29.50	55.50	Bulk	10

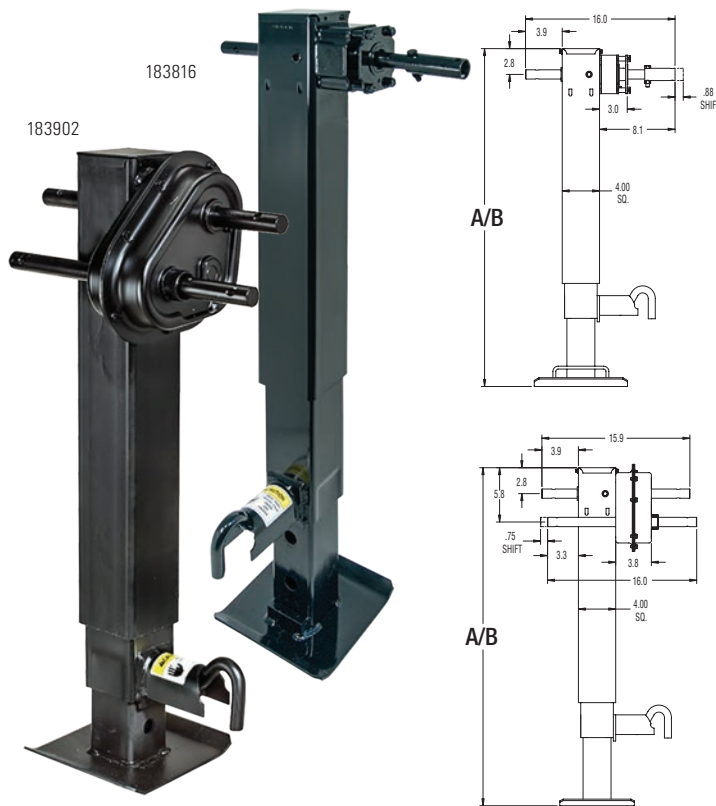

2-SPEED SQUARE JACKS

The First 2-Speed Gearbox

Designed with a Drop Leg Jack in Mind

The BULLDOG® 2-speed 12,000 lbs. support capacity square jack makes cranking easier when fully loaded and faster when unloaded. In low gear, the ratio delivers full lifting power at a super-smooth, easy-lifting 27 turns per 1 in. (planetary) and 29 turns per 1 in. (traditional) of travel. In high gear, the cranking ratio is a speedy 9 turns per 1 in. of travel, the fastest in its weight class.

- State of the art 2-speed gearbox with power and speed for the most effective and efficient jack at all loads
- Designed for today's standard agricultural, construction and industrial trailer applications.
- User friendly design makes operation smooth and easy
- Engineered alloys for enhanced strength, stability and side load capability
- Planetary gearbox fits within the width profile of the jack's outer tube, eliminating the need for spacers
- Painted outer tube, inner tube, and drop leg
- Crank sold separately
- Drop leg with standard disc foot offers 13.50 in. of additional adjustment

12K

Travel and Clearance Diagram

A= Retracted

B= Extended

C= Clearance Height

Part Number	Model Number	Support Capacity (lbs.)	Lift Capacity (lbs.)	Gearbox Style	Travel (in.)	A Retracted (in.)	B Extended (in.)	Pin Location	Companion	Packaging	Master Carton
Non-Spring Return											
183401	SWQ 183 DL-BX	12,000	10,000	Planetary	12.50	28.50	54.60	Side	182411	Bulk	20
183416	SWQ 183 DL-BX	12,000	10,000	Planetary	12.50	29.50	55.60	Front	182415	Bulk	20
183901	SWQ 180 DL-BX T	12,000	10,000	Traditional	12.50	29.50	55.60	Front	182415	Bulk	10
Spring Return											
183816	SWQ 183 DL-BX w/SR	12,000	10,000	Planetary	12.50	29.50	55.60	Front	182815	Bulk	20
183902	SWQ 180 DL-B w/SR T	12,000	10,000	Traditional	12.50	28.50	54.60	Side	182805	Bulk	10
183903	SWQ 180 DL-BX w/SR T	12,000	10,000	Traditional	12.50	29.50	55.60	Front	182815	Bulk	10
Replacement Parts											
500285	Planetary 2-Speed Sun Gear Kit									Poly Bag	25
500295	Traditional 2-Speed Gear Kit									Poly Bag	10
500330	Planetary Gearbox Kit									Boxed	1



500154
Bolt-On

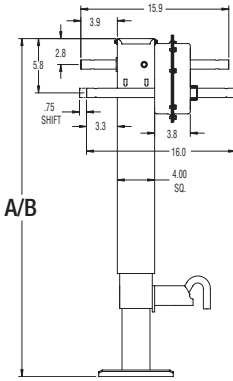
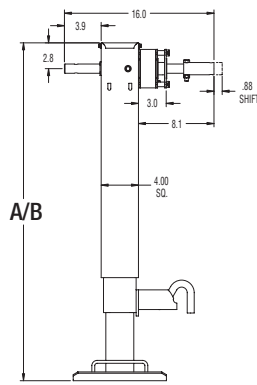

HEAVY DUTY 2-SPEED TANDEM LANDING GEAR

- AAR and TTMA rated (all values per pair):
 - 45,000 lbs. lifting capacity (@ 100 ft. lbs. input torque)
 - 90,000 lbs. static capacity
- Competitive cranking ratios:
 - Low speed gear 27.3 turns per in.
 - High speed gear 4.5 turns per in.
- High efficiency, double lead screw
- Heavy duty, self-leveling sand shoe
- Cross shaft sold separately
- Black painted finish
- Standard TTMA mount, mounted to inside of frame (bolt-on model, 500154)
- Heavy duty ban for added strength
- Ideal for horse, livestock and heavy duty trailers
- 5-year limited warranty



90K

Travel and Clearance Diagram

A= Retracted

B= Extended

C= Clearance Height

Part Number	Description	Tandem Capacity (lbs.)	Lift Capacity (lbs.)	Travel (in.)	A Retracted (in.)	B Extended (in.)	Packaging	Master Carton
500153	Tandem Non-Drop Leg Landing Gear - Set includes: Direct Weld 2-Speed and Single Speed Jacks and Crank, Cross Shaft Not Included	90,000	45,000	17.00	31.70	48.70	Bulk	10
500154	Tandem Non-Drop Leg Landing Gear - Set includes: TTMA Bolt-On Mount 2-Speed and Single Speed Jacks and Crank, Cross Shaft not included	90,000	45,000	17.00	31.70	48.70	Bulk	10
1839060383	2-Speed Jack, TTMA Bolt-On Mount, Crank Sold Separately	90,000	45,000	17.00	31.70	48.70	Bulk	10
1823050383	Single Speed Jack, Direct Weld, Crank Sold Separately	90,000	45,000	17.00	31.70	48.70	Bulk	10
Accessories								
8001090283	Crank, Mounting Hardware Included						Bulk	20
CS730300	72.75" Cross Shaft, Slotted Ends, Hardware Included						Bulk	25
500293	Tandem Landing Gear Jack 90K Gear Assembly, Includes: (1) Screw and Nut Assembly, (2) Retaining Pins, (1) Washer, (1) Bearing Bushing and (1) Thrust Bearing						Poly Bag	10
500294	Tandem Landing Gear Jack 90K Gear Assembly, Includes: (1) Grooved Pin, (1) Spring, (1) Chrome Steel Ball, (1) Spur Gear 32T, (1) Intermediate Spur Gear 32T/13T, (1) Input Spur Gear 32T/13T, (1) Woodruff Key and (1) 2-Speed Gearbox Gasket						Poly Bag	1

FARM JACKS

- Long handle for ease of use
- Removable handle and clamp
- Up to 8,000 lbs. capacity



Part Number	Description	Capacity (lbs.)	Height (in.)	Travel (in.)	Finish	Packaging	Master Carton
7060900	Farm Jack with Handle Holder	8,000	54.00	48.00	Red/Black	Boxed	1
7033400	Farm Jack	7,000	48.00	42.00	Red/Black	Boxed	1
7064200	Farm Jack	7,000	36.00	30.00	Red/Black	Boxed	1
Accessories							
7071300	ATV/UTV Universal Jack Mount Kit					Litho Box	1
7086500	Farm Jack Truck Box Mount Kit, Horizontal or Vertical Mount					Litho Box	4
7048400	Farm Jack Foot Plate, 10" x 10", 8,000 lbs. Capacity					Litho Box	2
7061520	Farm Jack Handle Holder, Durable PVC, Eliminates Rattle					Display Card	3
7088900	Farm Jack Carry Handle					Display Card	3
7064120	Farm Jack Maintenance Kit, Includes (2) Climbing Pins, (2) Climbing Pin Springs, (2) Cross Pins and (1) Handle Pin and Clip					Clamshell	6

RATCHET JACKS

BULLDOG® ratchet jacks are versatile tools for load bearing and lifting, height adjustment, three point hitch elevation, implement leveling, and wheel extension and retraction.

- 3/8 in. U-brackets tested to the endurance limit by a major OEM
- Stainless steel flat ratchet spring tested to 20 times the competition's life
- Reinforced steel assembly housing with user-friendly pawl
- Corrosion-resistant surfaces
- 2 zerk fittings, hexagonal jam nut
- Yellow zinc dichromate-plated 12 in. handle and cotter pin
- 1-1/8 in. - 5 yellow zinc dichromate-plated Acme screws
- U-bracket clevis ends with 1 in. holes
- Pins and clips included

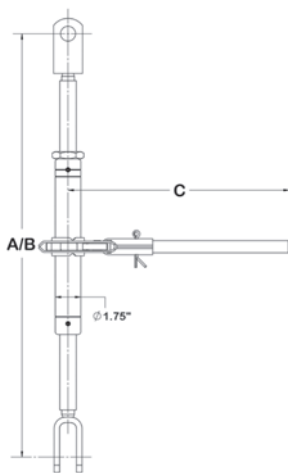

Travel and Clearance Diagram
 A= Retracted B= Extended
 C= Clearance Height

16K

Part Number	Description	Pull Capacity (lbs.)	Push Capacity (lbs.)	A Retracted (in.)	B Extended (in.)	C Clearance (in.)	Packaging	Master Carton
690020	Ratchet Mechanism Centered	16,000	10,000	20.00	28.00	15.10	Bulk	25
690071	Ratchet Mechanism Offset 3" to Right Side	16,000	10,000	20.00	28.00	15.10	Bulk	25

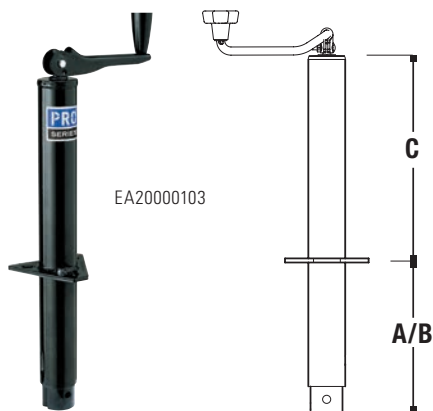

EA20000103

PRO SERIES™ ROUND JACKS

- Designed for use with recreational and utility trailers
- Bolt-on versions include all necessary mounting hardware
- Weld-on versions include mating mount and retaining ring
- A-frame models have black painted outer and inner tubes, all other models have black painted outer and clear zinc inner tubes

A-FRAME ROUND JACKS

- EA20000340 has clear zinc outer and inner tube

Part Number	Lift Capacity (lbs.)	Handle Style	Travel (in.)	A Retracted (in.)	B Extended (in.)	C Clearance (in.)	Packaging	Master Carton
RV20000103	2,000	Sidewind	14.00	9.00	23.00	13.00	Litho Box	96
RV20000303	2,000	Sidewind	14.00	9.00	23.00	13.00	Bulk	128
EA20000103	2,000	Topwind	14.00	8.00	22.00	11.00	Litho Box	112
EA20000303	2,000	Topwind	14.00	8.00	22.00	11.00	Bulk	220
EA20000340	2,000	Topwind	14.00	8.00	22.00	11.00	Bulk	220
1401000303	2,000	Topwind	15.00	5.50	20.50	16.00	Bulk	180
1400600303	5,000	Topwind	15.00	10.80	25.80	14.55	Bulk	112

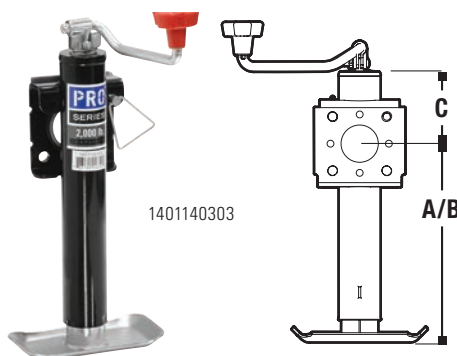

1401140303

RETAINING RING SWIVEL, BOLT-ON, ROUND JACKS WITH FOOTPLATE

- Mounting hardware included

Part Number	Lift Capacity (lbs.)	Handle Style	Travel (in.)	A Retracted (in.)	B Extended (in.)	C Clearance (in.)	Packaging	Master Carton
1400300303	2,000	Topwind	10.00	11.00	21.00	4.00	Bulk	96

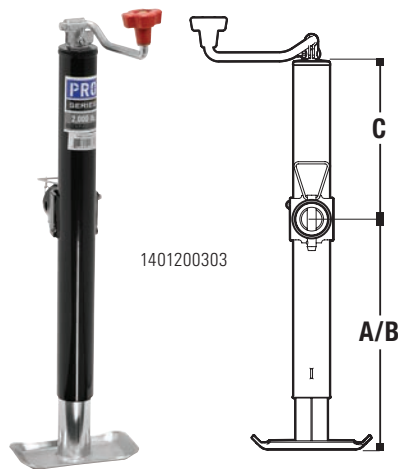

1401200303

RETAINING RING SWIVEL, WELD-ON, ROUND JACKS WITH FOOTPLATE

- Mating mount and retaining ring included

Part Number	Lift Capacity (lbs.)	Handle Style	Travel (in.)	A Retracted (in.)	B Extended (in.)	C Clearance (in.)	Packaging	Master Carton
1401140303	2,000	Topwind	10.00	11.00	21.00	4.00	Bulk	128
1401040303	2,000	Topwind	15.00	14.50	29.50	10.00	Bulk	64
1401020303	2,000	Sidewind	10.00	10.40	20.40	6.29	Bulk	96
1401030303	2,000	Sidewind	15.00	14.40	29.40	12.25	Bulk	80

TUBULAR SWIVEL, WELD-ON, ROUND JACKS WITH FOOTPLATE

- Mating mount and pull pin included

Part Number	Lift Capacity (lbs.)	Handle Style	Travel (in.)	A Retracted (in.)	B Extended (in.)	C Clearance (in.)	Packaging	Master Carton
1401060303	2,000	Sidewind	10.00	11.20	21.20	5.45	Bulk	100
1401080303	2,000	Sidewind	15.00	14.40	29.40	12.25	Bulk	64
1400400303	2,000	Topwind	10.00	11.00	21.00	4.00	Bulk	160
1401200303	2,000	Topwind	15.00	14.50	29.50	10.00	Bulk	96
1401420303	5,000	Sidewind	10.00	10.50	20.50	6.25	Bulk	100
1401440303	5,000	Sidewind	15.00	15.50	30.50	6.25	Bulk	96
1401460303	5,000	Topwind	10.00	11.20	21.20	4.00	Bulk	120
1401480303	5,000	Topwind	15.00	14.70	29.70	10.00	Bulk	96

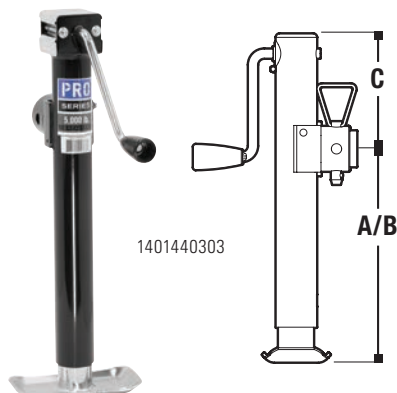

1401440303

PRO SERIES™ SQUARE JACKS

- Square jack dramatically improves side load strength
- Drop leg and fixed leg models available
- Tubular swivel models include mating mount and pull pin
- Direct weld to outer tube is standard
- Sidewind models - 1:1.86 gear ratio

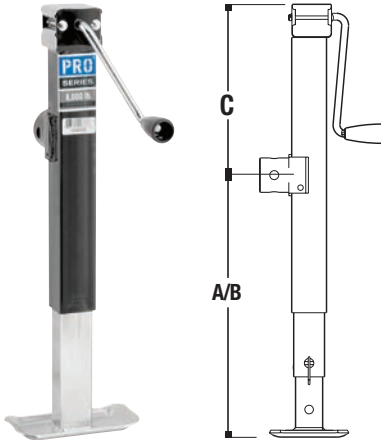

1400860383

WELD-ON, TUBULAR SWIVEL SQUARE JACK

- Black painted outer tube, clear zinc inner tube, fixed leg

Part Number	Support Capacity (lbs.)	Handle Style	Travel (in.)	A Retracted (in.)	B Extended (in.)	C Clearance (in.)	Packaging	Master Carton
1400860383	8,000	Sidewind	10.00	17.10	27.10	7.30	Bulk	25

DIRECT WELD SQUARE JACKS

- Adjustable drop leg with an additional 13.6 in. of travel

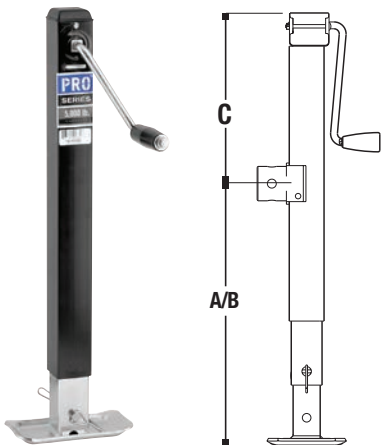

1401600383

Part Number	Support Capacity (lbs.)	Handle Style	Travel (in.)	A Retracted (in.)	B Extended (in.)	Inner Tube Finish	Packaging	Master Carton
1401600383	5,000	Sidewind	15.00	25.80	54.40	Clear Zinc	Bulk	25
1400800383	8,000	Topwind	15.00	22.90	51.50	Black	Bulk	25
1400850383	8,000	Sidewind	15.00	25.20	53.80	Black	Bulk	25

SPRING RETURN, DIRECT WELD SQUARE JACKS

- Adjustable spring return drop leg with an additional 13.5 in. of travel
- Crank included
- Black painted inner tube and drop leg

Part Number	Support Capacity (lbs.)	Handle Style	Travel (in.)	A Retracted (in.)	B Extended (in.)	Pin Location	Packaging	Master Carton
140094	12,000	Sidewind	12.50	27.25	53.25	Side	Bulk	50
1400950376	12,000	Sidewind	12.50	28.25	54.25	Side	Bulk	50
1400960376	12,000	Sidewind	12.50	28.25	54.25	Side	Bulk	50

NON-SPRING RETURN, DIRECT WELD SQUARE JACKS

- Adjustable spring return drop leg with an additional 13.5 in. of travel
- Crank included
- Black painted inner tube and drop leg

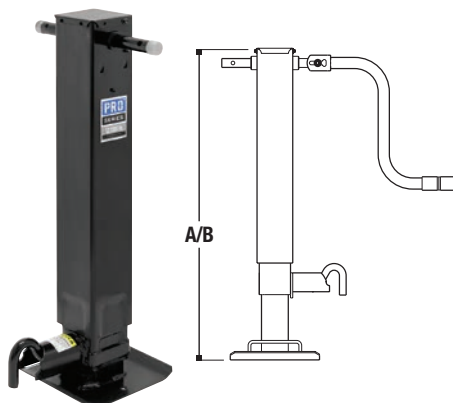

1400960376

Part Number	Support Capacity (lbs.)	Handle Style	Travel (in.)	A Retracted (in.)	B Extended (in.)	Pin Location	Packaging	Master Carton
1400980376	12,000	Sidewind	12.50	28.25	54.25	Side	Bulk	50
1400990376	12,000	Sidewind	12.50	28.25	54.25	Front	Bulk	50
1401010376	12,000	Sidewind	12.50	28.25	54.25	Side	Bulk	50
Accessory								
1400920383	12K Crank, Mounting Hardware and Clip, Black Painted Finish						Poly Bag	10

RACK / GEAR JACKS

750 lbs. A-Frame and Bolt-On

BULLDOG® experience and engineering know-how have produced a line of rack and gear jacks that are tough and trusted, the most preferred jacks used by trailer manufacturers in a variety of industries.

- Smooth-cranking 4 turns per in. of travel
- All-welded steel gear box with proven reliability for long term use at rated load
- Gray primer-painted steel wheel and gear box with weather-resistant clear zinc-plated rack post

1,200 lbs. Heavy-Duty

These heavy-duty rack jacks exemplify the BULLDOG® reputation for strength, providing additional lift capacity to a full 1,200 lbs.

Specially designed and manufactured to BULLDOG® unparalleled standards, they are ideal for heavier trailers and greater tongue weights.

- Powerful heavy-duty gear box with special steel alloy helical gear for extra lift capacity
- Extra heavy-duty gauge post for maximum side load strength
- Specially designed gusseted caster bracket for increased stability
- Red oxide primer-painted steel wheel and gear box with weather-resistant yellow zinc-plated rack post

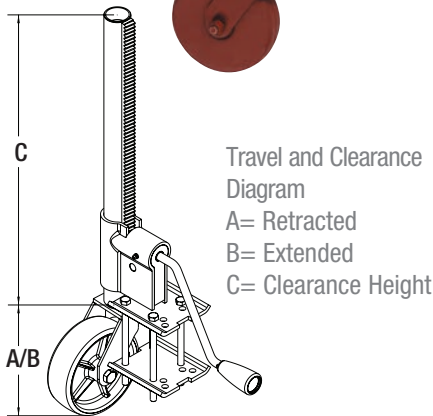

MOUNTING OPTIONS



165 Series - A-Frame, Welds or Bolts to Top of A-Frame Coupler



169 Series - Bolt-On, Fits up to 3" x 5" Rectangular Tongue



161 Series - Weld-On L-Bend Bracket, Welds to Side and Bottom of Tongue

Part Number	Model Number	Description	Lift Capacity (lbs.)	Includes		Travel (in.)	A Retracted (in.)	B Extended (in.)	C Clearance (in.)	Packaging	Master Carton
				*Gear Box	*Rack Post						
165411	HD 165 W	A-Frame 165 Series, Heavy-Duty Weld-On/Bolt-On Bracket, with Heavy-Duty 21" Long 1,200 lbs. Rack and Post, with Steel Wheel	1,200	0191410310	0190600324	16.00	7.50	23.50	20.30	Bulk	50
169201	169 RB	Rectangular, 169 Series, Bolt-On, Fits up to 3" x 5" Tongue, with Mounting Kit and Polyolefin Wheel with Black Finish	750	0181910378	0183080301	16.00	7.50	23.50	20.30	Bulk	50
Gear Boxes											
0181550317		165 Gear Box, A-Frame, Weld-On/Bolt-On Bracket, Long Side Crank for 160 Series								Bulk	50
0191410310		165 Gear Box, A-Frame, Weld-On/Bolt-On Bracket, Heavy Duty Long Side Crank for 165 Series								Bulk	50
0181610317		161 Gear Box, Weld-On L-Bend Bracket, Tight 90 Degree Side Crank for 160 Series								Bulk	50
Rack Posts											
0180060301		21" Post, 18" Rack with Steel Wheel for 160 Series								Bulk	50
0185100301		23.5" Post, 18" Rack, No Wheel, No Foot for 160 Series								Bulk	50
0185200301		23.5" Post, 18" Rack with Disc Foot for 160 Series								Bulk	50



STABILIZERS

Square tube stabilizers are fabricated from high strength, structural steel tubing, and are yellow zinc-plated for excellent corrosion-resistance. Common applications include cargo trailers, industrial implements, and equipment outriggers.

Part Number	Description	Static Capacity (lbs.)	A Range (in.)	Overall Length (in.)	Packaging	Master Carton
Stabilizer Kit						
SJL8 0300	Assembly Drop Leg and 1-1/2" Outer Tube, Includes Pin	2,000	8.00 to 27.00	20.00 Leg 8.00 Outer	Bulk	50
Stabilizer Tube and Drop Legs						
SJ1 0300	2" Square Outer Tube, Oil Finish, Pin Not Included	3,000	-	13.00	Bulk	100
SJ2 0324	Square Drop Leg with Adjustment Holes, Pin Not Included	3,000	25.00 to 37.00		Bulk	100
SJ3 0300	1-1/2" Square Outer Tube, Yellow Zinc Plated, Sleeve	3,000	-	8.00	Bulk	100
SJ4 0324	Square Drop Leg with Adjustment Holes, Pin Not Included	3,000	18.00 to 28.00	20.00	Bulk	100
SJ5 0324	Square Drop Leg with Adjustment Holes, Pin Not Included	3,000	0.50 to 19.50	20.00	Bulk	100
Stabilizer Lynch Pin						
LP516 0201	Service Kit, Pin 5/16" Diameter x 1-3/4" Long Lynch	-	-	-	Poly Bag	25



DROP LEGS

Part Number	Description	Packaging	Master Carton
DF35000324	For Square Jack, 1.71" Square Tube, Pin Included, 3,000 - 5,000 lbs. Rated	Bulk	25
500190	For Most 2,000 lbs. BULLDOG Round Jacks and BULLDOG Powered A-Frame Jacks, Pin Included, 5,000 lbs. Rated, Will Not Work with Pro Series Round Jacks and BULLDOG Round Jacks with Heavy Wall Inner Tubes	Boxed	112
500270	For Square Jack, 2.0" Square Tube, Pin Included, 8,000 lbs. Rated	Bulk	100
500329	Drop Leg and Pin	Bulk	100
500340	Replacement Part, Drop Leg Pull Pin Assembly, 7/8" x 2.25"	Bulk	50
500377	Drop Leg and Pin	Bulk	200

500190



CE555 0101

ACCESSORY WHEELS

Part Number	Description	Packaging	Master Carton
Poly Wheels			
CE555 0101	6" Caster with 2" Inside Diameter Fitting for 2" Jack Tube, 1,200 lbs. Rated	Boxed	1
500245	6" Caster with Pin 2" Inside Diameter Fitting for 2" Jack Tube, 1,200 lbs. Rated	Clamshell	5
Steel Wheels (Reduces Rated Capacities of any Jack)			
500282	Steel Wheel Kit	Boxed	1



0185640301

REMOVABLE FOOTPLATES

Part Number	Description	Packaging	Master Carton
0185640301	Removable Footplate with Pin. 2.1" Tall, Fits 2" Inner Tube, 2,000 - 5,000 lbs. Rated	Bulk	25
0181730324	Removable Footplate 6.2"	Bulk	50
018098	Removable Footplate with Pin. 6.2" Tall, Fits 2" Inner Tube, 2,000 - 5,000 lbs. Rated	Bulk	50
FP20000201	Foot with Hardware (Bolt Goes Trough 2" Jack Tube Holes), 2,000 lbs. Rated	Poly Bag	50
500244	Removable Footplate with Pin, Fits Jacks with 2" Inner Tube, (2.1" Tall)	Clamshell	6
F3500 0324	Removable Footplate with Pin, Fits Jacks with 2" SQUARE Inner Tube, (4.0" Tall)	Bulk	25
F2000 0301	Footpad for 2,000 - 5,000 lbs. Jacks	Bulk	50



FP20000201



FP2000 0301

TUBE MOUNTS

Part Number	Description	Packaging	Master Carton
Mounts			
500239	Male, Weld-On, For 9/16" Pin, 5,000 lbs. - Topwind Only, 150 Series, Topwind 170 Series	Clamshell	8
0050240300	Female, Weld-On, For 5/8" Pin, 3" O.D. for 190 Series	Bulk	25
0152790300	Male, Weld-On, For 5/8" Pin, 2" O.D for 170 Series	Boxed	50
0031550300	Female, Weld-On, 3/4" Pin for 190 Series	Boxed	25
0050050300	Male, Weld-On, 9/16" Pin	Poly Bag	50
0152710300	Female, Weld-On, 9/16" Pin, 2.5" O.D.	Poly Bag	50
0152730300	Male, Weld-On, 9/16" Pin for 150 Series and 170 Series	Poly Bag	50
7011800300	Male, Weld-On, 3/4" Pin for 190 Series	Bulk	10
005122	Female, Weld-On, 7/8" Pin for #182524 and #182374	Bulk	25
PQM19-00	Male, Weld-On, 5/8" Pin, 2.5" O.D.	Bulk	25
Retaining Ring Mounting Brackets			
P9222-00	Weld-On, Swivel Bracket, 1/2" Pin - 2,000 - 5,000 lbs. Rated	Bulk	50
P20520-00	Weld-On, Flat, Retaining Ring Swivel Plate for 3/8" Plunger Pin	Bulk	50
Swivel Trailer Mounts			
500339	Round Tube Male Weld-On U-Bracket for 5/8" Pull Pin	Bulk	50
500315	Weld-On, Swivel Trailer Mount, 5/8" Pin for 150 Series, 170 Series and 190 Series	Bulk	25



500239



P9222-00



500103



500177



500178



500337



500219



CA5550301



500326

PINS

Part Number	Description	Packaging	Master Carton
Pins			
500103	3/8" Plunger Pin Assembly, BULLDOG Only	Poly Bag	50
500310	3/4" Pull Pin (4.75" Long) with Chain without Drive Screw - 7,000 lbs.	Bulk	25
500341	7/8" Pin and Chain without Drive Screw	Poly Bag	50
Pin Kits			
500177	3/4" Drop Leg Plunger Pin Kit, 180 Series	Clamshell	12
500178	1/2" Plunger Pin Assembly Kit, 150 Series, 160 Series and 170 Series	Clamshell	12
500231	5/8" Pull Pin 3.5" Long with Chain and Drive Screw. 5,000 lbs. - Sidewind Only, Sidewind 170 Series, Crown 2,000/3,000/5,000 lbs.	Clamshell	12
500232	5/8" Pull Pin, 4.25" Long with Chain and Cotter Pin, 190 Series, Crown 7,000 lbs.	Clamshell	16
500243	9/16" Pull Pin 3.5" Long with Chain and Drive Screw, 5,000 lbs. - Topwind Only, 150 Series and Topwind 170 Series	Clamshell	12
Drop Leg Pins			
500337	Drop Leg Pull Pin Assembly, 3/4" x 3"	Bulk	4
500338	Drop Leg Pull Pin Assembly, 9/16" x 2.75"	Poly Bag	25
500340	Drop Leg Pull Pin Assembly, 7/8" x 2.25"	Bulk	50
0252010201	5/16" Snapper Pin, with Chain	Bulk	25
Lynch Pin Kit			
500219	Lynch Pin Kit, 0.563" Diameter	Poly Bag	25

SERVICE PARTS AND ACCESSORIES

Part Number	Description	Packaging	Master Carton
CA5550301	Caster Adapter Plate	Bulk	50
0031350300	A-Frame Support Plate, Forged Coupler	Bulk	50
SPB50 0300	Bottom Support Plate with 2.29" Diameter Hole, Cast and Stamped Couplers	Bulk	50
500326	2K Sidewind Jack Cap	Poly Bag	128



500223



500106



500241

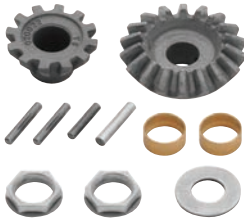

500212

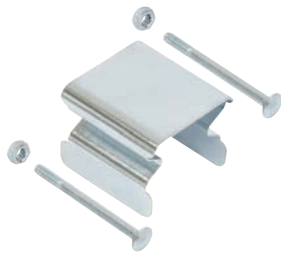

500205



500248



500246

ASSEMBLY KITS

Part Number	Description	Packaging	Master Carton
Bearing Kits			
500251	Bearing Kit for 2,000 lbs. Capacity Models, 150 Series	Clamshell	18
500223	Thrust Bearing for 5,000 lbs. Capacity Models, 170 Series, Crown 5,000 lbs.	Clamshell	18
500224	Thrust Bearing for 8,000 lbs. Capacity Models, 190 Series, Crown 7,000 lbs.	Clamshell	18
Gear Kits			
500106	Sidewind Gear Kit for up to and Including 5,000 lbs. Capacity Models, 139 Series and 159 Series and 170 Series, Crown 2,000/3,000/5,000 lbs.	Clamshell	18
500156	Sidewind Gear Kit for 8,000 lbs. Capacity Models, 190 Series, Crown 7,000 lbs. with 1/2" Inside Bottom Gear	Clamshell	10
5002581360	Sidewind Gear Kit, 190 Series, Crown 7,000 lbs. with 5/8" I.D. Bottom Gear	Poly Bag	50
800144	Service Kit Containing the Sidewind Crank 10.50", Bearing, Gears, Pins and Bushings for 10,000 lbs. Capacity 180 Series Sidewind Jacks	Poly Bag	25
500285	Sun Gear and Stub Shaft Assembly and Bushings for 12,000 lbs. Capacity Two Speed Planetary Gear Box	Poly Bag	25
500212	Gear Kit Including, Pins and Bushing – 12,000 lbs.	Poly Bag	50
Retaining Ring Kits			
500241	Swivel Retaining Ring, Fits Most Jack Capacities, 150 Series, 160 Series and 170 Series	Clamshell	10
Assembly Kit			
500217	Screw and Nut Assembly, Bearing, Support Washer and Retaining Pins for 12,000 lbs. Capacity BULLDOG Sidewind Jacks	Poly Bag	20
500250	Screw and Nut Assembly, Bearing, Support Washer and Retaining Pins for 12,000 lbs. Capacity BULLDOG Topwind Jacks	Poly Bag	10
Gear Box Cover			
500205	Gear Box Cover for 3,000 - 8,000 lbs. Capacity Sidewind Jacks, Includes Hardware	Poly Bag	50

KNOBS

Part Number	Description	Packaging	Master Carton
500248	Black Knob, Tear Drop, 139 Series, 159 Series, Sidewind 170 Series and 190 Series, Crown, 2,000 - 5,000 lbs.	Clamshell	12
500246	Red Knob, BULLDOG 150 Series, 160 Series and Topwind 170 Series, 2,000 - 5,000 lbs.	Clamshell	8

SIDEWIND CRANKS



Part Number	Description	Packaging	Master Carton
500256	Sidewind Crank with 5.80" Radius Assembly and Gear Kit, 150 Series with Plastic Cap, 2,000 lbs.	Clamshell	12
500105	Sidewind Crank with 6.50" Radius Assembly with Black Knob, 139 Series, 159 Series and 170 Series, Crown 2,000/3,000/5,000 lbs.	Clamshell	12
500171	Sidewind Crank with 8.50" Radius Assembly with Black Knob, 190 Series Square Jacks, Crown 7,000/8,000 lbs.	Clamshell	6
015181	Sidewind Crank, Vertical Clevis with 13.50" Radius, Black Primed Finish, Hardware Included	Bulk	400
800102	Sidewind Crank Assembly with 13.50" radius, Mounting Hardware Not Included, Extends 17.50" from the Jack, Black Primed Finish, Horizontal Clevis, Sidewind Handle	Bulk	100
701466	Removable Sidewind Crank with 13.5" Offset Radius, All Zinc-Plated Crank, Dual Handle Grips for Cranking and Shifting, For use with OEM Supplied Outboard Bushing or may be Attached Directly on Jack Gearbox	Poly Bag	10
800090	Sidewind Crank, Horizontal Clevis with 13.50" Radius, Black Primed Finish, Hardware Included	Bulk	25
8001090283	Sidewind Crank Assembly with 13.50" Radius, Mounting Hardware Included, Extends 20" from the Jack, Black Prime Finish, Vertical Clevis	Bulk	25
500312	Handle Clip	Bulk	100
800148	Sidewind Crank, 13.5" Radius with Soft Touch Handle Grip for 12,000 lbs. Jacks with 13/16" Hex Socket	Bulk	25
HDDS 0201	Shaft Handle, Hex Drive - Zinc for 800148	Bulk	25

TOPWIND CRANKS



Part Number	Description	Packaging	Master Carton
500180	Topwind Crank with 6.75" Radius, Assembly with Red Knob, Topwind 150 Series, 160 Series and 170 Series, 2,000 - 5,000 lbs.	Clamshell	6
500148	Topwind Crank with 9.00" Radius, Assembly with Black Knob, Topwind 190 Series, 7,000/8,000 lbs.	Clamshell	6
500344	Replacement Part, 12" Topwind Handle for 10K Square Jack	Poly Bag	25
800075	Topwind Crank 1" Tubing with 9.50" Radius, 12,000 lbs. Square	Bulk	400



500701†

500702†

4K JACK WITH POWERED DRIVE

LAST CHANCE

Part Number	Description	Substitute Part Number	Packaging	Master Carton
500701†	Black Cover, Includes Drop Leg, 4,000 lbs. Capacity	500199	Litho Box	1
500702†	White Cover, Includes Drop Leg, 4,000 lbs. Capacity	500200	Litho Box	1



500703†

500704†

4K JACK WITH POWERED DRIVE

LAST CHANCE

Part Number	Description	Substitute Part Number	Packaging	Master Carton
500703†	Black Cover, Includes Drop Leg, 3,500 lbs. Capacity	500187	Litho Box	1
500704†	White Cover, Includes Drop Leg, 3,500 lbs. Capacity	500188	Litho Box	1



500161†

POWERED FIFTH WHEEL LANDING GEAR

LAST CHANCE

Part Number	Description	Substitute Part Number	Packaging	Master Carton
500161†	RV Landing Gear Assembly, (2 Motors and Switches), 10,000 lbs. Capacity	500708	Boxed	1



183900†

2-SPEED SQUARE JACK

LAST CHANCE

Part Number	Description	Substitute Part Number	Packaging	Master Carton
183900†	Heavy-Duty 2-Speed Square Jack, Painted Outer Tube, Inner Tube and Drop Leg, 12,000 lbs. Support Capacity	183901	Bulk	10



190789†

SQUARE JACKS

LAST CHANCE

Part Number	Description	Substitute Part Number	Packaging	Master Carton
1401500383†	Direct Weld Square Jack, Topwind, 5,000 lbs. Capacity	1401600383	Bulk	25
1401520383†	Weld-On, Tubular Swivel Square Jack, Topwind, 5,000 lbs. Capacity	1400860383	Bulk	25
1401610383†	Weld-On, Tubular Swivel Square Jack, Sidewind, 5,000 lbs. Capacity	1400860383	Bulk	25
1400830383†	Weld-On, Tubular Swivel Square Jack, Topwind, 8,000 lbs. Capacity	1400860383	Bulk	25
190789†	Tubular Swivel Square Jack with Fixed Leg, without Mating Mount, Sidewind, 8,000 lbs. Capacity, (Model SWL 190 FL-BQ)	190756	Bulk	25
1907040176†	Tubular Swivel Square Jack with Drop Leg, Sidewind, 8,000 lbs. Capacity, (Model SWL 190 DL-BQ)	190704	Bulk	25



1823060383†

HEAVY DUTY TANDEM LANDING GEAR

LAST CHANCE

Part Number	Description	Substitute Part Number	Packaging	Master Carton
1839050383†	Heavy-Duty Tandem Landing Gear, Single Speed, Direct Weld Mount, 90,000 lbs. Tandem Capacity	500153	Bulk	10
1823060383†	Heavy-Duty Tandem Landing Gear, Single Speed, Bolt-On Mount, 90,000 lbs. Tandem Capacity	500154	Bulk	10



SJW 0324†

STABILIZER

LAST CHANCE

Part Number	Description	Substitute Part Number	Packaging	Master Carton
SJW 0324†	Stabilizer, Yellow Zinc	SJ2 0324	Bulk	100



165412†

RACK/GEAR JACKS

LAST CHANCE

Part Number	Description	Substitute Part Number	Packaging	Master Carton
165111†	A-Frame, Weld-On/Bolt-On Bracket with Disc Foot, 750 lbs. Capacity, (165 Series, Model 165 D)	165411	Bulk	50
165211†	A-Frame, Weld-On/Bolt-On Bracket, with Polyolefin Wheel, 750 lbs. Capacity, (165 Series, Model 165 R)	165411	Bulk	50
165311†	A-Frame, Weld-On/Bolt-On Bracket, with Steel Wheel, 750 lbs. Capacity, (165 Series, Model 165 W)	165411	Bulk	50
165412†	A-Frame, Heavy-Duty Weld-On/Bolt-On Bracket, with Heavy-Duty 21" Long 1,200 lbs. Rack and Post, with Steel Wheel, (165 Series, Model HD 165 WX)	165411	Bulk	50
162300†	L-Bend, Bolt-On with Steel Wheel, 750 lbs. Capacity, (162 Series, Model 162 W)	1623000117	Bulk	50
161300†	L-Bend, Weld-On with Steel Wheel, 750 lbs. Capacity, (161 Series, Model 162 W)	0180060301 0181610317	Bulk	50



0181640317†



0181620317†



0190600324†



018507†

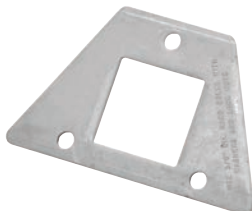

SPAQ500300†

GEAR BOXES

LAST CHANCE

Part Number	Description	Substitute Part Number	Packaging	Master Carton
0181910378†	169 Gear Box, Rectangular, Bolt-On Bracket for 169 Series	169201	Bulk	50
0181590317†	160 Gear Box, No Mounting Plate, 165 Series Crank	-	Bulk	50
0181620317†	162 Gear Box, Bolt-On L-Bend Bracket	-	Bulk	50
0181640317†	164 Gear Box, Stub Shaft, No Crank	-	Bulk	50
0181670317†	161S Gear Box, Weld-On L-Bend Retaining Ring Bracket Assembled for 160 Series	-	Bulk	50
0181710317†	160X Gear Box, No Bracket, Swivel Crank for 160 Series	-	Bulk	50
0181770317†	167 Gear Box, Weld-On Bracket for Round Tubing or Pipe, Long Side Crank for 160 Series	-	Bulk	50
0181890378†	169 Gear Box, Mounting Bracket Kit Included, Black	-	Bulk	50

RACK POSTS

LAST CHANCE

Part Number	Description	Substitute Part Number	Packaging	Master Carton
0180070301†	21" Post, 18" Rack with Poly Wheel for 160 Series	0180060301	Bulk	50
0190600324†	21" Post, 18" Rack, Heavy Duty, with Steel Wheel for 160 Series	0180060301	Bulk	50
0183080301†	21" Post, 18" Rack with Poly Wheel for 160 Series	0180060301	Bulk	50
0180340301†	34" Post, 30" Rack with Extra Long Steel Wheel for 160 Series	0180060301	Bulk	50
0185400301†	34" Post, 30" Rack, With Extra Long Disc Foot for 160 Series	0185200301	Bulk	50

STEEL CASTER

LAST CHANCE

Part Number	Description	Substitute Part Number	Packaging	Master Carton
018507†	Caster Assembly with 6" Steel Wheel for 155159 and 155300, 1,000 lbs. Rated	-	Poly Bag	25

SUPPORT PLATES

LAST CHANCE

Part Number	Description	Substitute Part Number	Packaging	Master Carton
SPAQ500300†	A-Frame Support Plate with 2.25" Square Hole	0031350300	Bulk	50
SPBQ500300†	Bottom Support Plate with 2.3" Square Hole	SPB50 0300	Bulk	50

† = Available while supplies last



TRAILER COUPLERS

BULLDOG® Collar Lok™ forged head couplers are the strongest in the industry and designed for the most rigorous and abusive application and user, "Tough and Trusted" since 1908. The design features of the **BULLDOG® Collar Lok™** coupler make it the only automatic and continuous tight ball fit in the industry and the distinctive and patented **Collar Lok™** appearance. The hinged ball socket design for easier alignment and hook-up, plus a clear visual indication of proper closure. The **BULLDOG® Collar Lok™** Couplers are in compliance with SAE standard J684.

Equally impressive is the **BULLDOG®** patented "Wedge-Latch®" cast coupler, which is offered in the heavy-duty A-frame design and in the adjustable coupler design. The adjustable coupler products can be adjusted up and down the channel to align best with the height of your tow vehicle. A level load helps the performance of both your tow vehicle and your trailer, making the most of your towing experience. **Wedge-Latch®** cast couplers are in compliance with SAE standard J864.

GOOSENECK COUPLERS

- BX1® Gooseneck Couplers K-3 - K-4
- Round Gooseneck Couplers K-5
- Square Gooseneck Couplers K-6
- Standard Round Gooseneck Couplers K-6
- King Pin Gooseneck Couplers K-7

HEAVY DUTY TRAILER COUPLERS

- Wedge-Latch™ Cast Couplers K-8
- Collar-Lok™ Round K-9
- Collar-Lok™ Square K-9
- Collar-Lok™ Adjustable K-10
- Collar-Lok™ A-Frame K-10

STAMPED COUPLERS

- A-Frame Stamped K-12
- Handwheel Stamped K-12
- Yoke Stamped K-12
- Fas-Lok® Straight Tongue Stamped K-10
- Adjustable Height Stamped K-12

LUNETTE RINGS K-6

FOLD-AWAY™ HINGE KITS K-11

FEATURED

BX1® GOOSENECK COUPLERS

The BULLDOG® BX1® coupler is the result of generations of design expertise and field experience. Incorporates innovative features that revolutionize the benefits available from a gooseneck coupler.

- **Allows shorter retracted length and less wasted length for trucks with high bed height via low-profile locking mechanism**
- Offers flexible mounting options with Next Generation locking plate coupler locking mechanism
- Easy hooking up, adjusting vertical height, and disconnecting
- Maintains smooth operation over time with grease fittings for every important operating part
- Continuous tight ball fit - ever-increasing cam tightening mechanism
- Protects against wear with enclosed locking pin mechanism
- Integrated feature to allow pad-locking the coupler to the ball (lock not included)
- Guides ball into socket more easily letting you miss by more than an inch with bottom locking plate 50% larger than competitors
- Lengthens life of locking mechanism with oil-impregnated bushings
- Fits ball better and reduces jarring through contour-formed edge on bottom locking plate
- Innovations that improve security, service life, and functionality
- New ball pocket design provides contact on both sides of the ball for substantially improved pull out strength - the only sliding-plate design that transfers part of the load to the top locking plate rather than only the bottom locking plate
- In compliance with SAE standard J2638 (outer tube must be installed and reinforced by the trailer manufacturer)
- See pages K-3 and K-4 for additional information



Square

Round

ADJUSTABLE CHANNEL MOUNT COUPLERS

- BULLDOG® couplers offer a wide variety of design, strength and function for all your adjustable coupler applications
- Channels sold separately



Collar Lok™
See page K-9

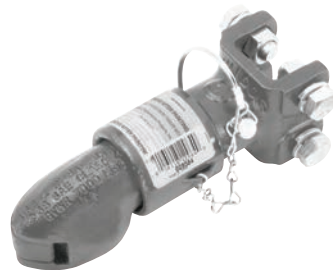

Rigid Mount
See page K-9



Cast Head
See page K-8



Stamped
See page K-12



BX1® ROUND GOOSENECK COUPLERS

The BULLDOG® BX1® coupler is the result of generations of design expertise and field experience. Incorporates innovative features that revolutionize the benefits available from a gooseneck coupler.



1289030300

1289070300

- **Allows shorter retracted length and less wasted length for trucks with high bed height via low-profile locking mechanism**
- Offers flexible mounting options with Next Generation locking plate coupler locking mechanism
- Easy hooking up, adjusting vertical height, and disconnecting
- Maintains smooth operation over time with grease fittings for every important operating part
- Continuous tight ball fit - ever-increasing cam tightening mechanism
- Protects against wear with enclosed locking pin mechanism
- Integrated feature to allow pad-locking the coupler to the ball (lock not included)
- Guides ball into socket more easily letting you miss by more than an inch with bottom locking plate 50% larger than competitors
- Lengthens life of locking mechanism with oil-impregnated bushings
- Fits ball better and reduces jarring through contour-formed edge on bottom locking plate
- Innovations that improve security, service life, and functionality
- New ball pocket design provides contact on both sides of the ball for substantially improved pull out strength - the only sliding-plate design that transfers part of the load to the top locking plate rather than only the bottom locking plate
- In compliance with SAE standard J2638 (outer tube must be installed and reinforced by the trailer manufacturer)

Patents Pending

Part Number	Description	Capacity (lbs.)	Retracted Height (in.)	Extended Height (in.)	Adjustment (in.)	Ball Size (in.)	Packaging	Master Carton
1289030300	BX1 Coupler, 4.5" Diameter x 20" Length Outer Tube, 4" Diameter x 27.2" Inner Tube, with BX1 Cast Coupler Head, 3/4" Load Bearing Pin, (2) Set Bolts, Raw, Labels Applied	20,000	27.50	35.50	8.00	2-5/16	Bulk	24
1289000300	BX1 Adjustable Gooseneck Coupler, 4.5" Diameter x 20" Length Outer Tube, 4" Diameter x 27.2" Inner Tube, with BX1 Cast Coupler Head, 3/4" Load Bearing Pin, (2) Set Bolts, Raw, Labels Applied	25,000	27.50	35.50	8.00	2-5/16	Bulk	24
Short Configuration								
1289070300	BX1 Coupler, 4.5" Diameter x 20" Length Outer Tube, 4" Diameter x 22.2" Inner Tube, with BX1 Cast Coupler Head, 3/4" Load Bearing Pin, (2) Set Bolts, Raw, Labels Loose	20,000	22.60	30.60	8.00	2-5/16	Bulk	24
1289080300	BX1 Coupler, 4.5" Diameter x 20.0" Length Outer Tube, 4" Diameter x 22.2" Inner Tube, with BX1 Cast Coupler Head, 3/4" Load Bearing Pin, (2) Set Bolts, Raw, Labels Loose	25,000	22.60	30.60	8.00	2-5/16	Bulk	24
1289040300	BX1 Coupler, 4.5" Diameter x 20.0" Length Outer Tube, 4" Diameter x 22.2" Inner Tube, with BX1 Cast Coupler Head, 3/4" Load Bearing Pin, (2) Set Bolts, Raw, Labels Loose	30,000	22.60	30.60	8.00	2-5/16	Bulk	24
Inner Tube Only								
1289170300	BX1 Coupler, 4" Diameter x 27.2" Inner Tube Only, with BX1 Cast Coupler Head, Raw, Labels Loose	20,000	-	-	-	2-5/16	Bulk	24
1289020300	BX1 Coupler, 4" Diameter x 27.2" Inner Tube Only, with BX1 Cast Coupler Head, Raw, Labels Loose	25,000	-	-	-	2-5/16	Bulk	24
1289050300	BX1 Coupler, Short Configuration, 4" Diameter x 22.2" Inner Tube Only, with BX1 Cast Coupler Head, Raw, Labels Loose	30,000	-	-	-	2-5/16	Bulk	24
Replacement Parts								
500289	BX1 Gooseneck Coupler Handle Replacement Kit for 20K, 25K and 30K						Poly Bag	8
500356	BX1 Gooseneck Coupler 5/16" Locking Pin						Bulk	50
0233100300	BX1 Gooseneck Coupler Outer Tube, 4.5" Diameter x 20" Length, Hole for 3/4" Load Bearing Pin, (2) Set Bolts						Bulk	24



1289130300

1289200300

Patents Pending

BX1® SQUARE GOOSENECK COUPLERS

The BULLDOG® BX1® coupler is the result of generations of design expertise and field experience. Incorporates innovative features that revolutionize the benefits available from a gooseneck coupler.

- **Allows shorter retracted length and less wasted length for trucks with high bed height via low-profile locking mechanism**
- Offers flexible mounting options with Next Generation locking plate coupler locking mechanism
- Easy hooking up, adjusting vertical height, and disconnecting
- Maintains smooth operation over time with grease fittings for every important operating part
- Continuous tight ball fit - ever-increasing cam tightening mechanism
- Protects against wear with enclosed locking pin mechanism
- Integrated feature to allow pad-locking the coupler to the ball (lock not included)
- Guides ball into socket more easily letting you miss by more than an inch with bottom locking plate 50% larger than competitors
- Lengthens life of locking mechanism with oil-impregnated bushings
- Fits ball better and reduces jarring through contour-formed edge on bottom locking plate
- Innovations that improve security, service life, and functionality
- New ball pocket design provides contact on both sides of the ball for substantially improved pull out strength - the only sliding-plate design that transfers part of the load to the top locking plate rather than only the bottom locking plate
- In compliance with SAE standard J2638 (outer tube must be installed and reinforced by the trailer manufacturer)

Part Number	Description	Capacity (lbs.)	Retracted Height (in.)	Extended Height (in.)	Adjustment (in.)	Ball Size (in.)	Packaging	Master Carton
1289130300	BX1 Coupler, 4.5" x 20" Square Outer Tube, 4" x 30.75" Square Inner Tube, with BX1 Cast Coupler Head, 3/4" Load Bearing Bolt, (2) Set Bolts, Raw, Labels Applied	25,000	30.80	38.80	8.00	2-5/16	Bulk	24
1289140300	BX1 Coupler, 4.5" x 20" Square Outer Tube, 4" x 30.75" Square Inner Tube, with BX1 Cast Coupler Head, 3/4" Load Bearing Bolt, (2) Set Bolts, Raw, Labels Applied	30,000	30.80	38.80	8.00	2-5/16	Bulk	24
1289200300	BX1 Coupler, 4.5" x 20" Square Outer Tube, 4" x 18.4" Square Inner Tube, with BX1 Cast Coupler Head, 3/4" Load Bearing Bolt, (4) Set Bolts, (2) Belly Bands, Raw, Labels Applied	40,000	22.00	24.60	2.60	3	Bulk	24
Short Configuration - Inner Tube Only								
1289210300	BX1 Coupler, 4" x 22.75" Square Inner Tube Only, with BX1 Cast Coupler Head, Raw, Labels Loose	25,000	-	-	8.00	2-2/16	Bulk	24
Accessories								
0233120300	Square Outer Tube, Weld On, 20" Length, 4-1/2" Tube, with Hex Head Bolt Hole, Dual Set Bolts and Labels, 20.6 lbs.						Bulk	24
Replacement Parts								
500289	BX1 Gooseneck Coupler Handle Replacement Kit for 20K, 25K and 30K						Poly Bag	8
500356	BX1 Gooseneck Coupler 5/16" Locking Pin						Bulk	50
500353	BX1 Gooseneck Coupler Repair Kit, Includes Handle Assembly, Locking Cam, Grease Fitting, Grooved Pin, Flanged Bushing and Torsion Spring						Bulk	24



ROUND GOOSENECK COUPLERS

BULLDOG® gooseneck couplers are quick and easy to engage and strong and secure on the road. Our unique, patented, extruded locking plate design and high-strength steel components make BULLDOG® gooseneck couplers 65% stronger than similar products.

- Easy-grip locking handle is accessible from any position, even while wearing a glove
- Self-centering locking plate lets you miss the ball by more than an inch
- Tight ball fit reduces jarring when changing speeds or on rough roads
- Heavy-duty construction provides unmatched strength
- User-friendly design is simple to use
- Quick to hook up and disconnect
- Easy vertical adjustment
- In compliance with SAE standard J2638

⚠ WARNING

Failure to close coupler securely before towing or failure to use with specified ball size may result in serious injury or death.

(outer tube must be installed and reinforced by the trailer manufacturer)

Part Number	Description	Capacity (lbs.)	Retracted Height (in.)	Adjustment (in.)	Ball Size (in.)	Packaging	Master Carton
Round Gooseneck Fixed Coupler							
0287690300	Fixed Base Coupler	20,000	33.00	-	2-5/16	Bulk	24
Round Gooseneck Adjustable Coupler							
0287600300	Adjustable Gooseneck Coupler, 4.5" Diameter x 20" Length Outer Tube, 4" Diameter x 27.2" Inner Tube, with Cast Locking Plates, 3/4" Load Bearing Pin, (1) Set bolt, Raw, Labels Applied	20,000	29.20	8.00	2-5/16	Bulk	24
0287620300	Adjustable Gooseneck Coupler, 4.5" Diameter x 20" Length Outer Tube, 4" Diameter x 27.2" Inner Tube, with Cast Locking Plates, 3/4" Load Bearing Pin, (1) Set bolt, Raw, Labels Applied, with Outer Tube Cap	20,000	29.30	8.00	2-5/16	Bulk	24
0287760300	Adjustable Gooseneck Coupler, 4.5" Diameter x 20" Length Outer Tube, 4" Diameter x 27.2" Inner Tube, with GN24 Coupler Head, 3/4" Load Bearing Pin, (1) Set bolt, Raw, Labels Applied	20,000	29.50	8.00	2-5/16	Bulk	24
0289340317	Adjustable Gooseneck Coupler, 4.5" Diameter x 20" Length Outer Tube, 4" Diameter x 27.2" Inner Tube, with GN24 Coupler Head, 3/4" Load Bearing Pin, (1) Set bolt, Primer Gray, Labels Applied	25,000	28.10	8.00	2-5/16	Bulk	24
0289250300	Adjustable Gooseneck Coupler, 4.5" Diameter x 20" Length Outer Tube, 4" Diameter x 27.2" Inner Tube, with Cast Locking Plates, 3/4" Load Bearing Pin, (1) Set bolt, Raw, Labels Applied	25,000	29.30	8.00	2-5/16	Bulk	24
0289500300	Adjustable Gooseneck Coupler, 4.5" Diameter x 20" Length Outer Tube, 4" Diameter x 27.2" Inner Tube, with Cast Locking Plates, 3/4" Load Bearing Pin, (2) Set bolts, Raw, Labels Applied	30,000	29.30	8.00	2-5/16	Bulk	24
Inner Tube Only							
0287610300	Adjustable Gooseneck Coupler, 4" Diameter x 27.2" Inner Tube Only, with Cast Locking Plates, Labels Applied	20,000	-	-	2-5/16	Bulk	24
0287650300	Adjustable Gooseneck Coupler, 4" Diameter x 27.2" Inner Tube Only, with GN24 Coupler Head, Labels Loose	20,000	-	-	2-5/16	Bulk	24
Outer Tube Only							
0233010300	Outer Tube Only, 20" Length, 4.5" Round Tube, with Hole for 3/4" Load Bearing Pin, (1) Set Bolt					Bulk	24
0233100300	Outer Tube Only, 20" Length, 4.5" Round Tube, with Hole for 3/4" Load Bearing Pin, (2) Set Bolts					Bulk	24
Gooseneck Coupler Head							
GN24 0200	Cast Steel Gooseneck Coupler Head, Fits 3" or 4" Diameter Tubing, Quick and Easy Latching Action Eliminates Need to be in Tow Vehicle for Hook-Up	24,000	-	-	2-5/16	Boxed	8
1542S01	Repair Kit for GN24 0200, Kit Includes Torsion Spring, Coupler Locking Shaft, Curved Handle Assembly, 3/4" Shaft Retaining Ring, Centerlock Nut 1/2-13					Poly Bag	25
Replacement Parts							
0287740300	Gooseneck Coupler Kit, Includes Coupler Assembly, Locking Pin Assembly, Locking Pin Cover, BULLDOG Label, and Warning Label, 2-5/16" Ball Size					Poly Bag	24
0233060301	Pin Kit, Includes Cotter Pin, 3/4" x 5-1/2" with Finger Loop					Boxed	10
500296	Gooseneck Couplers Bolt Kit, Includes (1) Jam Nut, (1) Set Screw and (1) Adjusting Nut					Poly Bag	10



028900

0289600300

SQUARE GOOSENECK COUPLERS

You won't find a coupler that's faster or easier to use than the square gooseneck from BULLDOG®. Its user-friendly design makes hookup and release swift and secure.

- Easy-grip locking handle is accessible from any position
- Self-centering locking plate lets you miss the ball by more than an inch
- Tight ball fit reduces jarring when changing speeds or on rough roads
- Heavy-duty high-strength fabricated steel components are as strong as heavy cast iron but lighter and less brittle
- User-friendly design enables quick, easy hookup and release
- Locking handle cover protects working parts
- Cam locking pin affords easy vertical adjustment
- Pinch bolt design
- In compliance with SAE standard J2638

(outer tube must be installed and reinforced by the trailer manufacturer)

⚠ WARNING

Failure to close coupler securely before towing or failure to use with specified ball size may result in serious injury or death.

Part Number	Description	Capacity (lbs.)	Retracted Height (in.)	Extended Height (in.)	Adjustment (in.)	Ball Size (in.)	Packaging	Master Carton
0289600300	Adjustable Gooseneck Coupler, 4.5" x 20" Length Square Outer Tube, 4" x 30.75" Square Inner Tube, with Cast Locking Plates, 3/4" Load Bearing Bolt, (1) Set bolt, Raw, Labels Applied	25,000	32.00	40.00	8.00	2-5/16	Bulk	24
028900	Adjustable Gooseneck Coupler, 4.5" x 20" Length Square Outer Tube, 4" x 30.75" Square Inner Tube, with Cast Locking Plates, 3/4" Load Bearing Bolt, (2) Set Bolts, Raw, Labels Applied	30,000	32.00	39.00	7.00	2-5/16	Bulk	24
0289800300	Topwind Crank Adjustable Gooseneck Coupler, 4.5" x 20" Length Square Outer Tube, 4" x 30.75" Square Inner Tube, with Cast Locking Plates, 3/4" Load Bearing Bolt, (1) Set Bolt, Raw, Labels Applied	30,000	32.00	40.00	8.00	2-5/16	Bulk	24
Inner Tube Only								
0288660300	Adjustable Gooseneck Coupler, 4.0" x 30.75" Square Inner Tube Only, with Cast Locking Plates, Raw, Labels Applied	25,000	-	-	-	2-5/16	Bulk	24



0287800300

0287820300

PRO SERIES™ ROUND GOOSENECK COUPLERS

- Dual set of bolts and labels
- Handle hold-open feature
- User-friendly design is simple to use
- Quick to hook up and disconnect
- Easy vertical adjustment
- Raw finish

⚠ WARNING

Failure to close coupler securely before towing or failure to use with specified ball size may result in serious injury or death.



Handle Hold-Open



Load Bearing Pin

Part Number	Description	Capacity (lbs.)	Retracted Height (in.)	Extended Height (in.)	Adjustment (in.)	Ball Size (in.)	Packaging	Master Carton
0287790300	Adjustable Gooseneck Coupler, 4.5" Diameter x 19" Length Outer Tube, 4" Diameter x 25.5" Inner Tube, with Cast Locking Plates, (2) Set Bolts, Raw, Labels Loose	20,000	26.70	34.70	8.00	2-5/16	Bulk	24
0287800300	Adjustable Gooseneck Coupler, 4.5" Diameter x 19" Length Outer Tube, 4" Diameter x 25.5" Inner Tube, with Cast Locking Plates, (2) Set Bolts, Raw, Labels Loose	25,000	26.70	34.70	8.00	2-5/16	Bulk	24
0287820300	Adjustable Gooseneck Coupler, 4.5" Diameter x 19" Length Outer Tube, 4" Diameter x 27.2" Inner Tube, with Cast Locking Plates, 3/4" Load Bearing Pin, (1) Set Bolt, Raw, Labels Loose	25,000	26.70	34.70	8.00	2-5/16	Bulk	24

KING PIN GOOSENECK COUPLERS



0289640300

0289590300

KING PIN GOOSENECK COUPLERS

- Allows gooseneck trailer to be towed with vehicles equipped with a fifth wheel hitch
- Features dual set bolts
- Round model features exclusive load bearing pin
- Square model features exclusive load bearing pinch bolt
- Available with or without outer tube
- In compliance with SAE standard J2638 (outer tube must be installed and reinforced by the trailer manufacturer)

WARNING

Failure to close coupler securely before towing or failure to use with specified ball size may result in serious injury or death.

Part Number	Description	Capacity (lbs.)	Retracted Height (in.)	Extended Height (in.)	Adjustment (in.)	Packaging	Master Carton
0289580300	King Pin Adjustable Gooseneck Coupler, 4.5" Diameter x 20" Length Outer Tube, 4" Diameter x 22.2" Inner Tube, 3/4" Load Bearing Pin, (2) Set Bolts, Raw, Labels Loose	25,000	23.30	31.30	8.00	Bulk	24
0289590300	King Pin Adjustable Gooseneck Coupler, 4.5" x 20" Length Square Outer Tube, 4" x 22.75" Square Inner Tube, 3/4" Load Bearing Bolt, (2) Set Bolts, Raw, Labels Loose	30,000	23.30	31.30	8.00	Bulk	24
Inner Tube Only							
0289640300	King Pin Adjustable Gooseneck Coupler, 4" Diameter x 22.2" Inner Tube Only, Raw, Labels Loose	25,000	23.30	31.30	8.00	Bulk	24
0289650300	King Pin Adjustable Gooseneck Coupler, 4" x 22.75" Square Inner Tube Only, Raw, Labels Loose	30,000	23.30	31.30	8.00	Bulk	12
Service Kit							
0289SB0140	Adjustable Gooseneck Pinch Bolt Kit					Poly Bag	10



63023



63060



1291020340

LUNETTE RINGS

- Designed with strength, durability and ease of use in mind
- Forged steel construction for high strength and wear resistance
- Simple bolt-on installation

Part Number	Description	Diameter (in.)	Capacity (lbs.)	Finish	Packaging	Master Carton
63023	4 Bolt Flange Lunette Ring	2-1/2	42,000	Black Paint	Litho Box	4
63022	1-1/2" Shank Lunette Ring	2-1/2	15,000	Black Paint	Litho Box	4
63036	Adjustable Lunette Ring with Hardware and Channel	3	24,000	Black Paint	Litho Box	4
63060	Adjustable Lunette Ring with Hardware	3	24,000	Black Paint	Litho Box	4
1291020383	Adjustable Lunette Ring	3	14,000	Black Paint	Bulk	288
1291020340	Adjustable Lunette Ring	3	14,000	Clear Zinc	Bulk	288
Accessories						
63033	Hardware Mounting Kit for 63023				Poly Bag	14
AC300 0300	Mounting Channel, 4 Hole, 3 Position, 8" Height				Bulk	-
AC500 0300	Mounting Channel, 6 Hole, 5 Position, 11-3/4" Height				Bulk	-
024202	Adjustable Height Lunette Ring Hardware Kit				Poly Bag	240

HEAVY DUTY CAST COUPLERS

Designed for utility, horse/livestock, cargo, and construction trailer applications, BULLDOG® couplers are the strongest in the industry. The patented cast head “Wedge-Latch®” coupler design is offered in heavy-duty, A-frame, and convenient adjustable height models. Adjustable couplers assure level operation for trailers when pulled by a variety of vehicles. The replaceable latching hardware allows for longer service life.

- Quick and easy to engage
- Strong and secure on the road
- Patented Wedge-Latch® ball clamp design
- Quick to hook up and disconnect
- In compliance with SAE standard J684

⚠ WARNING

Failure to close coupler securely before towing or failure to use with specified ball size may result in serious injury or death.



44150W0317

4425000317

Part Number	Description	Capacity (lbs.)	Overall Length (in.)	Latch	Ball Size (in.)	SAE Class	Packaging	Master Carton
Wedge-Latch Cast Head Couplers								
43805W0317	Round Jack Mount, 50° A-Frame	8,000	18.00	Wedge-Latch	2	IV	Bulk	25
44125W0317	Round Jack Mount, 50° A-Frame	12,500	18.00	Wedge-Latch	2-5/16	IV	Bulk	25
44150W0317	Round Jack Mount, 50° A-Frame	15,000	18.00	Wedge-Latch	2-5/16	IV	Bulk	25
44150WQ317	Square Jack Mount, 50° A-Frame	15,000	18.00	Wedge-Latch	2-5/16	IV	Bulk	25
44150WH301	Round Jack Mount, 50° A-Frame, for Bolt-On Applications	15,000	18.00	Wedge-Latch	2-5/16	IV	Bulk	25
Wedge-Latch Flat Mount Cast Head Couplers								
4420000317	Cast Head, 4-1/2" Mount Pattern, Gray Primer Coat	20,000	-	Wedge-Latch	2-5/16	-	Bulk	25
4425000317	Cast Head, 4-1/2" Mount Pattern, Gray Primer Coat	25,000	-	Wedge-Latch	2-5/16	-	Bulk	25
Accessory Part, Wedge-Latch Flat Mount Cast Head Coupler								
PL4 0201	Coupler Pin with Lanyard 5/16" with 4 Link Chain and Tab	-	-	-	-	-	Poly Bag	25
Wedge-Latch Adjustable Height Cast Head Couplers								
A200C 0317	Cast Head Includes Mounting Hardware, Adjustable Height	8,000	8.50	Wedge-Latch	2	IV	Bulk	25
A2003C0317	Cast Head Includes Bolts and 3-Position Channel, Adjustable Height	8,000	9.25	Wedge-Latch	2	IV	Bulk	25
A2005C0317	Cast Head Includes Bolts and 5-Position Channel, Adjustable Height	8,000	9.25	Wedge-Latch	2	IV	Bulk	25
A256C 0317	Cast Head Includes Mounting Hardware, Adjustable Height	14,000	9.25	Wedge-Latch	2-5/16	IV	Bulk	25
A2563C0317	Cast Head Includes Bolts and 3-Position Channel, Adjustable Height	14,000	9.50	Wedge-Latch	2-5/16	IV	Bulk	25
A2565C0317	Cast Head Includes Bolts and 5-Position Channel, Adjustable Height	14,000	9.50	Wedge-Latch	2-5/16	IV	Bulk	25
Accessories and Replacement Parts, Adjustable Height Channel Bracket								
AC300 0300	4-Hole, 3-Position Bracket, with 4" of Vertical Adjustment, Adjustable Height	-	8.00	-	-	-	Boxed	10
AC500 0300	6-Hole, 5-Position Bracket, with 8" of Vertical Adjustment, Adjustable Height	-	11.75	-	-	-	Boxed	5
66 0801	2" Ball Size Wedge-Latch Repair Kit, Includes Latch Lever, Ball Clamp, and Replacement Hardware	-	-	-	2	-	Poly Bag	12
67 0801	2-5/16" Ball Size Wedge-Latch Repair Kit, Includes Latch Lever, Ball Clamp, and Replacement Hardware	-	-	-	2-5/16	-	Poly Bag	12

NOTE: Other custom-made designs are available upon request



HEAVY DUTY COLLAR-LOK™ COUPLERS

- Designed for utility, horse/livestock, cargo, and construction trailer applications, BULLDOG® Collar-Lok™ are the strongest in the industry
- The BULLDOG® design features the only automatic and continuously tight ball fit in the industry
- A variety of coupler styles, tongue mounts, and latches allow configurations to match virtually any trailer
- Adjustable couplers assure level operation for trailers when pulled by a variety of different vehicles
- Strong in both static and dynamic loading conditions
- Hinged ball socket for easy hook up
- Clear, visual indication of proper closure
- In compliance with SAE standard J684

⚠ WARNING
 Failure to close coupler securely before towing or failure to use with specified ball size may result in serious injury or death.



ROUND TUBULAR MOUNT

- 2-1/4 in. outside diameter steel tubing
- 1-3/4 in. inside diameter steel tubing

Part Number	Model Number	Capacity (lbs.)	Overall Length (in.)	Latch	Ball Size (in.)	SAE Class	Packaging	Master Carton
028381	2B2H	5,000	10.75	High Profile	2	III	Bulk	50
028242	2B2M	5,000	10.75	Pin Style	2	III	Bulk	50
028461	4B2H	12,500	12.75	High Profile	2-5/16	-	Bulk	50
028442	4B2M	12,500	12.75	Pin Style	2-5/16	-	Bulk	50



SQUARE RECTANGULAR MOUNT

- High strength steel for 3 in. square or rectangular trailer tongues

Part Number	Model Number	Capacity (lbs.)	Overall Length (in.)	Latch	Ball Size (in.)	SAE Class	Packaging	Master Carton
028382 ◊	2B4H	5,000	16.25	High Profile	2	III	Bulk	50
028244	2B4M	5,000	16.25	Pin Style	2	III	Bulk	50
028387 ◊	3B4H	7,000	16.25	High Profile	2	IV	Bulk	50
028243	3B4M	7,000	16.25	Pin Style	2	IV	Bulk	50
028462 ◊	4B4H	12,500	16.50	High Profile	2-5/16	-	Bulk	50
028444	4B4M	12,500	16.50	Pin Style	2-5/16	-	Bulk	50

◊ Denotes Most Popular



ROUND STRAIGHT MOUNT

- High strength steel for 3-1/2 in. outside diameter round trailer tongues

Part Number	Model Number	Capacity (lbs.)	Overall Length (in.)	Latch	Ball Size (in.)	SAE Class	Packaging	Master Carton
028383	2B5H	5,000	16.25	High Profile	2	III	Bulk	50

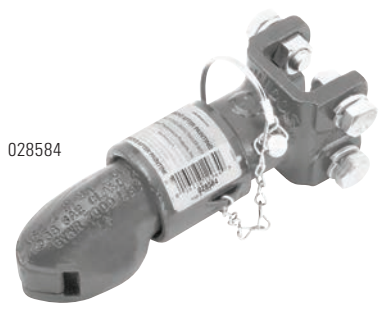

028584

RIGID MOUNT - ADJUSTABLE CHANNEL MOUNT

- Rigid anti-rattle design using 4 bolts
- Easy one tool installation
- Fits inside 3 in. wide channel

Part Number	Model Number	Capacity (lbs.)	Overall Length (in.)	Latch	Ball Size (in.)	SAE Class	Packaging	Master Carton
028584	3B6M	7,000	9.5	Pin Style	2	IV	Bulk	50
028585	4B6M	12,500	10.00	Pin Style	2-5/16	-	Bulk	50



028657

ADJUSTABLE CHANNEL MOUNT

- Fits inside 3 in. wide channel

Part Number	Model Number	Capacity (lbs.)	Overall Length (in.)	Latch	Ball Size (in.)	SAE Class	Packaging	Master Carton
028390 ◊	3B6M	7,000	9.50	Pin Style	2	IV	Bulk	50
028630 ◊	4B6M	12,500	10.00	Pin Style	2-5/16	-	Bulk	25
028657	5B6M	15,000	10.00	Pin Style	2-5/16	-	Bulk	25

◊ Denotes Most Popular



028288

A-FRAME MOUNT

- High strength steel for 50-degree trailer tongues
- Tapped mounting holes optional

Part Number	Model Number	Capacity (lbs.)	Overall Length (in.)	Latch	Ball Size (in.)	SAE Class	Packaging	Master Carton
028384	2B8H	5,000	16.00	High Profile	2	III	Bulk	50
028288 ◊	2B8L	5,000	16.00	Low Profile	2	III	Bulk	50
028386	3B8H	7,000	16.00	High Profile	2	IV	Bulk	50
028287 ◊	3B8L	7,000	16.00	Low Profile	2	IV	Bulk	50
028463	4B8H	12,500	16.50	High Profile	2-5/16	-	Bulk	50
028499 ◊	4B8L	12,500	16.50	Low Profile	2-5/16	-	Bulk	50

◊ Denotes Most Popular



028386

HEAVY DUTY A-FRAME MOUNT

- High strength steel for 50-degree trailer tongues
- Tapped mounting holes optional
- Black primed finish

Part Number	Model Number	Capacity (lbs.)	Overall Length (in.)	Latch	Ball Size (in.)	SAE Class	Packaging	Master Carton
028656	5B8H	15,000	16.50	High Profile	2-5/16	-	Bulk	50
028655	5B8L	15,000	16.50	Low Profile	2-5/16	-	Bulk	50



028656



028655

REPLACEMENT PARTS

Part Number	Description	Packaging	Master Carton
024200	Collar-Lok Coupler Kit, Includes High Profile Latch Handle, Latch Wire, Latch Pin, Push Nut, and Cotter Pin	Poly Bag	25
500354	Coupler Cap Spring	Poly Bag	25



STRAIGHT TONGUE STAMPED FAS-LOK® COUPLERS

- The most popular coupler mechanism ever developed, the Fas-Lok® originated as a Fulton® brand and is offered in a full line of SAE Class I through IV rated straight tongue stamped couplers
- The Fas-Lok® latching mechanism allows quick and easy trailer hook-up, and is factory adjusted for convenience



INDUSTRY LEADING CORROSION PROTECTION
• 600 hour salt spray rating per ASTM B117

Part Number	Description	Capacity (lbs.)	Ball Size (in.)	SAE Class	Finish	Label	Packaging	Master Carton
11200 0101	2" Wide Channel	2,000	1-7/8	I	100 Hr.	Labeled	Boxed	6
11250 0101	2-1/2" Wide Channel	2,000	1-7/8	I	Zinc	Labeled	Boxed	6
11300 0101	3" Wide Channel	2,000	1-7/8	I	100 Hr.	Labeled	Boxed	25
22200 0101	2" Wide Channel	3,500	2	II	Z-Max 600	Labeled	Boxed	6
22300 0101	3" Wide Channel	3,500	2	II	Zinc	Labeled	Bulk	100
34300 0301	3" Wide Channel	5,000	2	III	Z-Max 600	No Label	Bulk	50
34300 0317	3" Wide Channel	5,000	2	III	Primed	No Label	Bulk	50
34600 0301	3" Wide Channel, Cast Ball Clamp	6,000	2	IV	Z-Max 600	No Label	Bulk	50

FOLD-AWAY™ HINGE KITS

- Fulton® High Performance Series Fold-Away™ hinge kits are ideal for boat trailers that can be just a little too long to fit inside smaller garages. These high quality, precision engineered products provide options for solving this common problem
- Converts standard trailer tongues into fold-away configurations while preserving the existing coupler
- Delivers strength at the pivot point with precisely machined heavy duty hinges made from die cast steel
- Choose the Fold-Away™ product that fits your needs from among several varieties made to fit standard trailer tongue dimensions
- Features Z-Max™ 600 hour clear zinc finish
- Easy to install bolt-on application with complete instruction manual
- Includes all mounting hardware
- Only recommended for trailers with steel tongues

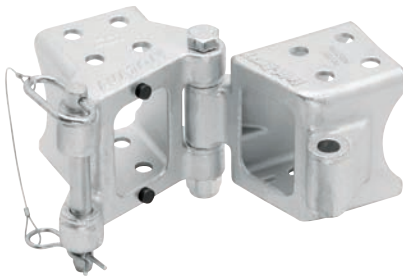

HDPB330101

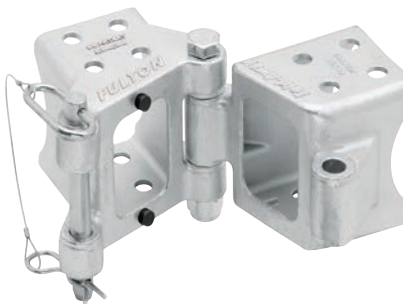

HDPB350101

Part Number	Description	Capacity (lbs.)	Pivot Length (in.)	Finish	Packaging	Master Carton
Bolt-On						
HDPB230101	2" x 3" Trailer Tongues	Up to 5,000	Up to 48	Z-Max 600	Boxed	2
HDPB330101	3" x 3" Trailer Tongues	Up to 5,000	Up to 48	Z-Max 600	Boxed	2
HDPB340101	3" x 4" Trailer Tongues	Up to 7,500	Up to 48	Z-Max 600	Boxed	2
HDPB350101	3" x 5" Trailer Tongues	Up to 9,000	Up to 48	Z-Max 600	Boxed	2
Replacement Parts						
500705	Pivot Bumpers, (4)				Poly Bag	100
500334	Pivot Pin, 5/8" x 4-1/2" with Cotter Pin and Lanyard for 3" x 3" Models				Poly Bag	40
500335	Pivot Pin, 5/8" x 5-1/2" with Cotter Pin and Lanyard for 3" x 4" Models				Poly Bag	40
500336	Pivot Pin, 5/8" x 6-1/2" with Cotter Pin and Lanyard for 3" x 5" Models				Poly Bag	40

A-FRAME STAMPED COUPLERS

- 50-degree A-frame

44305R0317



44314R0303



Part Number	Description	Capacity (lbs.)	Ball Size (lbs.)	SAE Class	Finish	Packaging	Master Carton
E333050303	Weld-On	5,000	2	III	Black E-Coat	Bulk	186
33305H0301	Bolt-On	5,000	2	III	Zinc	Bulk	186
E443050303	Weld-On, Low Profile Latch	10,000	2-5/16	IV	Black E-Coat	Bulk	186
44305R0317	Weld On, Wedge-Latch	10,000	2-5/16	IV	Gray Primer	Bulk	50
44305R0500	Weld On, Wedge-Latch	10,000	2-5/16	IV	Oily	Bulk	50
44311H0301	Bolt-On, Wedge-Latch	11,000	2-5/16	IV	Zinc	Bulk	186
44314R0303	Weld On, Wedge-Latch	14,000	2-5/16	IV	Black Paint	Bulk	50
Accessories							
CH 0701	Handi-Grip Coupler Handle					Clamshell	10
Replacement Parts							
64 0801	Coupler Repair Kit for 44305R Series Couplers					Poly Bag	12

HANDWHEEL STAMPED COUPLERS

3305H0301



Part Number	Description	Capacity (lbs.)	Ball Size (lbs.)	SAE Class	Finish	Packaging	Master Carton
308 0217	2-7/8" Channel, Handwheel Latch	5,000	2 to 2-1/8	III	Primed	Boxed	10
Accessories							
CH 0701	Handi-Grip Coupler Handle					Clamshell	10
Replacement Parts							
52 0801	Coupler Repair Kit for Handwheel Couplers					Poly Bag	12

YOKE STAMPED COUPLERS

- Round jack mount 50-degree A-frame
- Weld-on

E338050303



Part Number	Description	Capacity (lbs.)	Ball Size (lbs.)	SAE Class	Finish	Packaging	Master Carton
E338050303	Class III Coupler	5,000	2	-	Black Paint	Bulk	230
E438050303	Class IV Coupler	8,000	2	-	Black Paint	Bulk	230
Accessories							
CH 0701	Handi-Grip Coupler Handle					Clamshell	10

ADJUSTABLE HEIGHT STAMPED COUPLERS

- Patented Wedge-Latch® ball clamp design
- Mounting hardware included (mounting bracket sold separately)

A200S 0303



Part Number	Description	Capacity (lbs.)	Ball Size (lbs.)	SAE Class	Finish	Packaging	Master Carton
A200S 0303	Adjustable Coupler	8,000	2	-	Black Paint	Bulk	175
A256S 0303	Adjustable Coupler	14,000	2-5/16	-	Black Paint	Bulk	160
Mounting Brackets							
AC300 0300	3 Position, Raw Finish, Mounting Hardware Sold Separately, 8" Height					Boxed	10
AC500 0300	5 Position, Raw Finish, Mounting Hardware Sold Separately, 11.75" Height					Boxed	5
024202	Mounting Hardware					Poly Bag	240



WINCHES

Fulton® has produced the finest winches in the industry for over 50 years. The result of engineering innovation, superior materials, and rugged manufacturing, Fulton® Winches offer the greatest applications coverage for your unique needs. Ranging from the stylish and innovative F2® Winch to the wide variety of one-speed, two-speed winches and brake winches, Fulton® offers a style and capacity to meet virtually every need.

The Fulton® F2® Winch brings an innovative and attractive design that will update any marine trailer. Its clean, high-tech look is sleek and contemporary, and will complement the look of even high end boat and trailer combinations. Fulton® continues to evolve industry-changing improvements in both performance and style with the Fulton® F2® series of products.

TRAILER WINCHES

Powered Marine Winches	L-2
Winch Selection	L-3
F2® Series	L-4
XLT® Series	L-5
Single Speed	L-5
Two Speed	L-6
Brake Winches	L-7 - L-8
Brake Winch Specs	L-8

ELECTRIC WINCHES

ATV	L-9
Utility	L-9
Heavy Duty	L-10
Accessories	L-12

HOISTS

Hydraulic	L-11
Electric	L-11
Accessories	L-12

FEATURED



500621

Wireless Remote

XLT™ POWERED MARINE WINCHES

- Requires connection to a min. of a 650 CCA 12V DC battery
- Convenient wireless remote included
- Rugged strap includes swiveling hook to prevent twisting
- Power in / Power out and free spool
- 3-position guide so strap comes out straight
- Manual override using standard tools in case of power loss
- Easy to access light and winch control switches
- LED lights on back and bottom to help at dusk and dawn
- Patented E.I.S. Easy Install System - drop in bolts, apply lock ring, adjust bolts and tighten
- Premium Sharkskin™ finish:
 - Maximum corrosion resistance
 - Used in salt water environments and other demanding climate applications



Part Number	Description	Max Boat Weight (lbs.)	Max Boat Length (ft.)	Packaging	Master Carton
500620	7.0 XLT Powered Marine Winch and Wireless Remote	7,000	20	Litho Box	1
500621	10.0 XLT Powered Marine Winch and Wireless Remote	10,000	26	Litho Box	1



HOOK SWIVELS 360°



3-POSITION GUIDE



EASY FREE SPOOL



EASY INSTALL SYSTEM



LEDS ON BACK AND BOTTOM



WIRELESS REMOTE

SELECTING A PULLING WINCH

To Select Winch Capacity:

1. Minimum Winch Capacity = Maximum Weight of Boat, Including Motor, Fuel, Gear ÷ 2

Example:

- Boat, Motor, Fuel, Gear Weight = 2,800 lbs.
- $2,800 \div 2 = 1,400$ lbs.
- **Select 142200 winch rated at 1,500 lbs.**

2. If shallow water or steep inclined launches are expected to be used ÷ Maximum Weight by 1.5

Example:

- Boat, Motor, Fuel, Gear Weight = 3,100 lbs.
- $3,100 \div 1.5 = 2,067$ lbs.
- **Select 142410 winch rated at 2,600 lbs.**

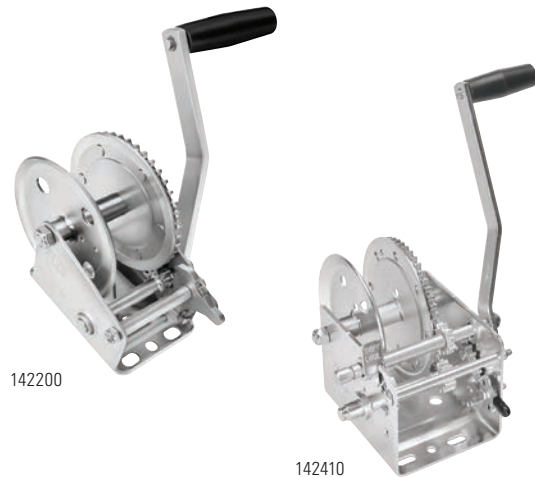

COMMON PULLING APPLICATION

SELECTING A LIFTING WINCH

To Select Winch Capacity:

1. Minimum Winch Capacity = Maximum Line Load

Example:

- Maximum Line Load = 1,450 lbs.
- **Select 143100 winch, rated at 1,500 lbs.**



COMMON LIFTING APPLICATIONS

NOTES:

1. Fulton brand two-speed winches are designed for boat trailer and other pulling applications, which require the freewheeling feature of ratchet type winches. If moving loads requiring vertical lifting, or positive load control in both directions, choose a Fulton brake winch.
2. All Fulton brand winches are rated on the first layer of recommended rope, strap, or cable. The winch load capacity must be derated as additional layers are used. Derate the capacity 10% per additional layer of rope, strap, or cable.
3. Fulton brand winches are NOT designed to be human hoists and should never be operated when there are persons on, around, or under the load being moved.

F2® SERIES TRAILER WINCHES

- The F2® Winch addresses the need for attractive design in every element of a marine trailer. It complements the look of even high end boat and trailer combinations and continues the industry changing improvements in both performance and style of the Fulton® F2® series of products.
- Attractive design to compliment the F2® jack series for a custom look
- Enclosed frame design for a sleek, strong stylish look to compliment your boat and customize your trailer
- Soft ergonomic adjustable handle
- Dual gear drum operates smoothly
- Features patented E.I.S. - "Easy Install System"
- Premium Sharkskin™ finish: - Maximum corrosion resistance - Used in salt water environments and other demanding climate applications
- Lifetime limited warranty



CE Compliant

1,600 lbs. Winch Model:

- Handle switches from left to right hand drive configuration

2,000 lbs. Winch Model:

- Handle switches from left to right hand drive configuration
- Center drive enclosed ratchet system
- User-friendly pull-turn knob to engage ratchet plunger pin

3,200 lbs. Winch Model:

- Center drive enclosed ratchet system
- User-friendly pull-turn knob to engage ratchet plunger pin
- Self-engaging one-hand system shifts from high to low speed



EASY INSTALL SYSTEM



FW16000101



FW20000101



FW32000101

Part Number	Capacity (lbs.)	Adjustable Handle Lengths (in.)	Gear Ratio	Mounting Hardware Included	Strap (ft. x in.)	Finish	Strap Included	Packaging	Master Carton
FW16000101	1,600	6 to 7	4.1:1	Yes	20 x 2	Sharkskin	Yes	Litho Box	4
FW20000101	2,000	6 to 9	5.1:1	Yes	20 x 2	Sharkskin	Yes	Litho Box	4
FW32000101	3,200	6 to 9	5.1:1 3.16:1	Yes	20 x 2	Sharkskin	Yes	Litho Box	4

Replacement Parts									
FW3200S01	2-Speed Sun Gear Kit							Poly Bag	6
500350	Top Cover for F2 Winches							Poly Bag	25
500351	Back Cover for FW2000 and FW3200							Poly Bag	32
0133313S00	Winch Handle Kit for FW1600							Poly Bag	10
1596S01	Ratchet Repair Kit for FW1600							Poly Bag	25
0133310S00	Ratchet Repair Kit for FW2000 and FW3200							Poly Bag	12
0133311S00	Winch Handle Kit for FW2000 and FW3200							Poly Bag	10
0133312S00	2-Speed Planetary Drive System Repair Kit for FW3200							Poly Bag	1
501135	Ratchet Pawl Spring for FW1600							Poly Bag	25
501136	Mounting Hardware for F2 Winches							Poly Bag	25
501137	6" to 7" Handle for F2 Winches							Poly Bag	10
501138	6" to 9" Handle for F2 Winches							Poly Bag	10

SINGLE SPEED TRAILER WINCHES

SINGLE SPEED TRAILER WINCHES

Our full line of Fulton® single speed winches are designed to meet your toughest pulling demands. Our winch's solid drum gear construction delivers smooth cranking and durability. All models feature ZMAX™ 600 clear zinc finish for superior corrosion resistance.

- The 1,100 lbs. to 1,800 lbs. capacity models feature a 2-way ratchet with neutral pawl
- For end user convenience, models are available with the strap and hook included
- Our XLT™ Series include stylized thermoplastic covers and come standard with the strap and hook included
- 5-year limited warranty



• 600 hour salt spray rating per ASTM B117

CE Compliant



142311 XLT



142305



142208

Part Number	Capacity (lbs.)	Handle Length (in.)	Max Mechanical Advance**	Rope (ft. x in.)	Strap (ft. x in.)	Recommended Strap Bolt Sizes (in.)	Strap Included	Packaging	Master Carton	
142001	900	7.00	39:1	36 x 1/4	15 x 2	1/4 x 2-1/2 Grade 5	No	Litho Box	6	
142006	900	7.00	39:1	36 x 1/4	15 x 2	1/4 x 2-1/2 Grade 5	Yes	Litho Box	6	
142100	1,100	7.00	43:1	30 x 5/16	20 x 2	1/4 x 2-1/2 Grade 5	No	Litho Box	6	
142102	1,100	7.00	43:1	30 x 5/16	20 x 2	1/4 x 2-1/2 Grade 5	Yes	Litho Box	6	
142103	1,300	8.00	49:1	30 x 5/16	20 x 2	1/4 x 2-1/2 Grade 5	No	Litho Box	6	
142311 (XLT)	1,500	8.00	43:1	-	20 x 2	5/16 x 2-1/2 Grade 5	Yes	Litho Box	4	
142200	1,500	8.00	49:1	20 x 5/16	20 x 2	1/4 x 2-1/2 Grade 5	No	Litho Box	6	
142203	1,500	8.00	49:1	20 x 5/16	20 x 2	1/4 x 2-1/2 Grade 5	Yes	Litho Box	6	
142208	1,500	8.00	49:1	20 x 5/16	20 x 2	1/4 x 2-1/2 Grade 5	Yes	Litho Box	6	
142300	1,800	8.00	62:1	20 x 7/16	20 x 2	3/8 x 2-3/4 Grade 5	No	Litho Box	4	
142305	1,800	8.00	62:1	20 x 7/16	20 x 2	3/8 x 2-3/4 Grade 5	Yes	Litho Box	4	
142314 (XLT)	1,800	8.00	62:1	-	20 x 2	3/8 x 2-3/4 Grade 5	Yes	Litho Box	3	
Accessories										
501103	Winch Handle, 6" Offset								Poly Bag	6
501107	Winch Handle, 7" Offset								Poly Bag	6
501106	Winch Handle, 8" Offset								Poly Bag	6
501109	Winch Handle, 9" Offset								Bulk	40
501108	Winch Handle, 10" Offset								Poly Bag	6
501101	Winch Handle, 11" Offset								Poly Bag	6
501202	Nylon Web Winch Strap with Hook, 2" x 20', 2,600 lbs, Maximum Working Load								Clamshell	6
501207	Nylon Web Winch Strap with Hook, 2" x 20', 3,200 lbs, Maximum Working Load								Clamshell	4
WS20HD0600	Heavy Duty Nylon Web Winch Strap with Hook, 2" x 20', 4,000 lbs, Maximum Working Load								Clamshell	4

**Maximum Mechanical Advance - Based on first layer of recommended line on the drum. For maximum efficiency, use only the amount of line required.

TWO SPEED TRAILER WINCHES

Make light work of heavy loads with Fulton® brand two-speed winches. One fast speed for quick pulling, a second low speed for increased mechanical advantage.

- Our shift lock design allows changing gears without moving the crank handle from shaft to shaft. Just lift the shift lock and slide the shaft into the desired gear position. Shift lock holds the shaft in gear.
- Neutral, free-wheel position allows quick line pay out without spinning the handle
- Optional handbrake kit (501201) purchased separately and available for all two-speed winches and can be installed after the winch is mounted
- Winch mounting hardware sold separately, refer to instruction sheet for recommended bolt size and grade
- 5-year limited warranty



INDUSTRY LEADING CORROSION PROTECTION
• 600 hour salt spray rating per ASTM B117

CE Compliant

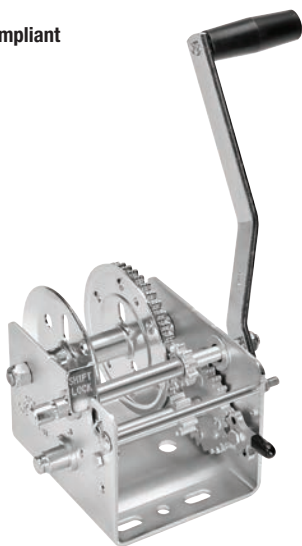

142400

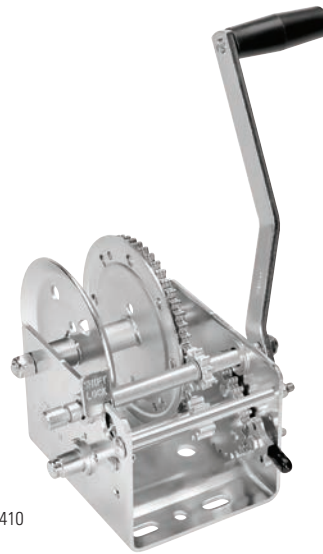

142410

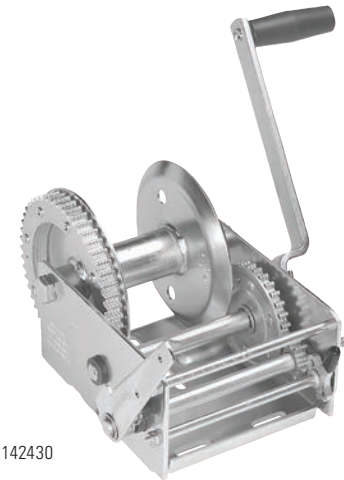

142430

Part Number	Capacity (lbs.)	Handle Length (in.)	Max Mechanical Advance**	Cable (ft. x in.)	Strap (ft. x in.)	Recommended Strap Bolt Sizes (in.)	Hub Size (in.)	Hand Brake***	Strap Included	Cable Included	Packaging	Master Carton
142400	2,000	10.00	87:1	-	20 x 2	3/8 x 2-3/4 Grade 5	1.00	501210	No	-	Litho Box	3
142410	2,600	10.00	108:1	-	20 x 2	3/8 x 2-3/4 Grade 5	1.00	501210	No	-	Litho Box	3
142415	2,600	10.00	108:1	-	20 x 2	3/8 x 2-3/4 Grade 5	1.00	501210	Yes	-	Litho Box	3
142411	2,600	10.00	108:1	-	20 x 3	3/8 x 3-1/2 Grade 5	1.00	Included	No	-	Litho Box	3
142420	3,200	10.00	79:1	100 x 7/32	-	Cable Only	1.75	501210	-	No	Litho box	3
142430	3,700	10.00	102:1	140 x 7/32	-	Cable Only	1.75	Included	-	No	Litho Box	2

Accessories

501108	Winch Handle, 10" Offset										Poly Bag	6
501110	Winch Handle, 10" Removable, for 3,700 lbs. Capacity Models										Poly Bag	6
501202	Nylon Web Winch Strap with Hook, 2" x 20', 2,600 lbs. Maximum Working Load										Clamshell	6
501207	Nylon Web Winch Strap with Hook, 2" x 20', 3,200 lbs. Maximum Working Load										Clamshell	4
WS20HD0600	Heavy Duty Winch Strap with Hook, 2" x 30', 4,000 lbs. Maximum Working Load										Clamshell	4
WC325 0100	Galvanized Winch Cable and Hook, 3/16" x 25', 4,200 lbs. Break Strength										Clamshell	4
WC750 0100	Galvanized Winch Cable and Hook, 7/32" x 50', 5,600 lbs. Break Strength										Poly Bag	6

Replacement Parts

501132	Ratchet Repair Kit for 2,000 - 3,200 lbs. Capacity Models										Poly Bag	10
501134	Input Shaft Kit for 2,000 - 3,200 lbs. Capacity Models										Poly Bag	10
501210	Hand Brake Kit for all 2-Speed Models										Poly Bag	10
501133	Ratchet Repair Kit for 3,700 lbs. Capacity Models										Poly Bag	10
501135	Ratchet Spring for all 2-Speed Models										Poly Bag	10

**Maximum Mechanical Advance - Based on first layer of recommended line on the drum. For maximum efficiency, use only the amount of line required.

***Brake Kit 501210 available as option not furnished. Only winches that are shown to accommodate steel cable should be used with steel cable. Cable keeper kits are included with the winches specifying steel cable. Winches rated for steel cable have a larger drum hub to reduce or lessen chance of kinking or fraying.

BRAKE WINCHES

- Fulton® self-activating automatic brake winches hold the load securely when the crank handle is released
- Drum hubs are 10 times the recommended cable size to maximize cable life
- Popular applications include construction light towers, grain augers, manual fork lifts, and boat lifts
- For especially demanding applications select models feature covered drums and gear trains, along with a dual ratchet system
- 5-year limited warranty



INDUSTRY LEADING CORROSION PROTECTION
• 600 hour salt spray rating per ASTM B117

CE Compliant

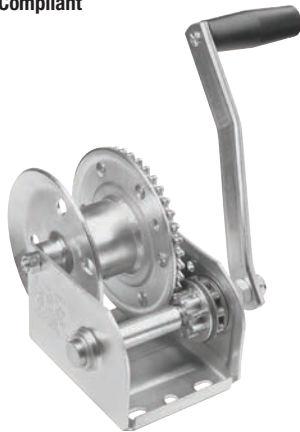

143001

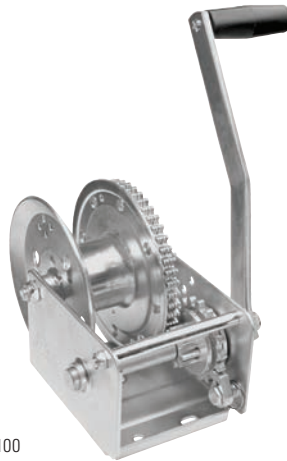

143100

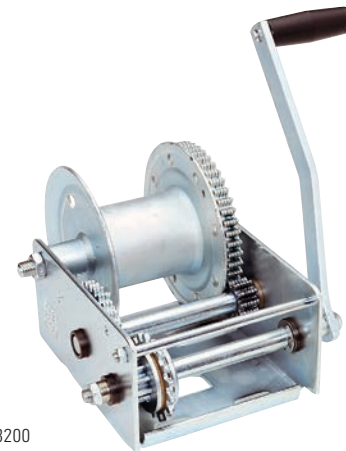

143200

Part Number	Max Rated Line Pull		Max Cable Size Data (7 x 9 Galvanized Aircraft Cable)			Mechanical Data					Packaging	Master Carton
	1st Layer (lbs.)	Full Drum (lbs.)	Diameter (in.)	Drum Storage (ft.)	Test Strength (lbs.)	Gear Ratio	Handle Length (in.)	Drum Hub Diameter (in.)	Covered Gears	Cable Included		
143001	1,000 (454 kg)	500 (227 kg)	7/32 (5.5 mm)	50 (15 m)	5,600 (2540 kg)	4:1	11 (27.9 cm)	2-1/4 (57 mm)	No	No	Litho Box	6
143005	1,000 (454 kg)	500 (227 kg)	7/32 (5.5 mm)	50 (15 m)	5,600 (2540 kg)	4:1	11 (27.9 cm)	2-1/4 (57 mm)	Yes	No	Litho Box	6
143100	1,500 (680 kg)	700 (318 kg)	1/4 (6 mm)	70 (21 m)	7,000 (3175 kg)	5:1	11 (27.9 cm)	2-1/2 (63 mm)	No	No	Litho Box	4
143104	1,500 (680 kg)	700 (318 kg)	1/4 (6 mm)	70 (21 m)	7,000 (3175 kg)	5:1	11 (27.9 cm)	2-1/2 (63 mm)	Yes	No	Litho Box	4
143200	2,500 (1134 kg)	1,500 (680 kg)	5/16 (8 mm)	70 (21 m)	9,800 (4445 kg)	15.8:1	11 (27.9 cm)	3-1/8 (79 mm)	No	No	Litho Box	2
Accessories												
501101	Winch Handle, 11" Offset										Poly Bag	6
WC325 0100	Galvanized Cable and Hook, 3/16" x 25', 4,200 lbs. Break Strength										Clamshell	4
WC750 0100	Galvanized Cable and Hook, 7/32" x 50', 5,600 lbs. Break Strength										Poly Bag	6
Replacement Parts												
501124	Gear Cover for 1,000 lbs. Capacity Models										Poly Bag	5
501130	Gear Cover for 1,500 lbs. Capacity Models										Poly Bag	5
501122	Friction Disc for 1,000 lbs. Capacity Models										Poly Bag	5
501115	Friction Disc for 1,500 lbs. Capacity Models										Poly Bag	5
501118	Pinion Shaft Kit for 1,500 lbs. Capacity Models										Poly Bag	5
501121	Pinion Shaft Kit for 2,500 lbs. Capacity Models										Poly Bag	5
501131	Intermediate Shaft Kit for 2,500 lbs. Capacity Models										Poly Bag	5
501125	Ratchet Repair Kit for 1,000 lbs. Capacity Models										Poly Bag	5
501117	Ratchet Repair Kit for 1,500 lbs. and 2,500 lbs. Capacity Models										Poly Bag	5
501001	Cable Keeper for all Models										Clamshell	12

STANDARD ECONOMY BRAKE WINCHES

- Self activating automatic brake
- Solid drum gear construction
- Covered braking system
- Enlarged drum size to extend cable life
- 8 in. handle length
- Passes all applicable SAE and ASAE standards

 Compliant



KR10000301

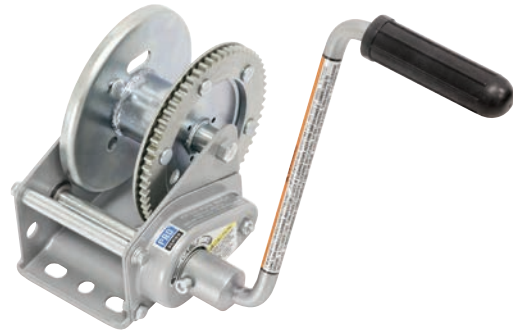

KR15000301

Part Number	Capacity (lbs.)	Handle Length (in.)	Gear Ratio	Cable Capacity (ft. x in.)	Covered Gears	Cable Included	Packaging	Master Carton
KR10000301	1,000	8.00	3:5:1	50 x 7/32	No	No	Boxed	6
KR15000301	1,500	8.00	5:1:1	50 x 7/32	No	No	Boxed	6
Accessories								
WC325 0100	Galvanized Cable and Hook, 3/16" x 25', 4,200 lbs. Break Strength						Clamshell	4
WC750 0100	Galvanized Cable and Hook, 7/32" x 50', 5,600 lbs. Break Strength						Poly Bag	6
Replacement Parts								
500357	Handle Kit for Standard Economy Brake Winches						Poly Bag	30
500366	Cable Keeper for Standard Economy Brake Winches						Poly Bag	50

BRAKE WINCH DIMENSIONS

- Dimensions not intended for Standard Economy Brake Winches

Brake Winch Dimensions							
Capacity (lbs.)	A (in.)	B (in.)	C (in.)	D (in.)	E (in.)	F (in.)	
1,000	5.25	7.46	3.69	5.89	1.90	11.00	
1,500	6.56	9.23	4.39	7.08	2.46	11.00	
2,500	8.63	11.13	5.60	7.13	2.08	11.00	

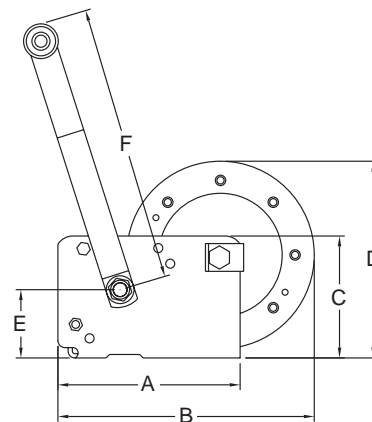

NOTES:

1. Winch mounting hardware sold separately. Refer to instruction sheet for recommended bolt size and grade.
2. Fulton brand two-speed winches are designed for boat trailer and other pulling applications, which require the freewheeling feature of ratchet type winches. If moving loads requiring vertical lifting, or positive load control in both directions, choose a Fulton brake winch.
3. All Fulton brand winches are rated on the first layer of recommended rope, strap, or cable. The winch load capacity must be derated as additional layers are used. Derate the capacity 10% per additional layer of rope, strap, or cable.
4. Fulton brand winches are NOT designed to be human hoists and should never be operated when there are persons on, around, or under the load being moved.
5. Only winches that are shown to accommodate steel cable should be used with steel cable. Cable keeper kits are included with the winches specifying steel cable. Winches rated for steel cable have a larger drum hub to reduce or lessen chance of kinking or fraying.

ATV WINCHES

BULLDOG™ ATV/Utility Winches are compact, lightweight, and flexible, yet they're sturdy tools ready for action when you need them most.

- Power in and power out for powerful retraction and rapid rope payout
- High-torque motor for a higher pull at a lower amp
- 3-stage planetary gearbox for reliable performance in tough conditions
- Includes roller fairlead, hand-held wired remote control, handle bar remote control, snatch block, and mounting bracket



500630

Part Number	Motor	Rated Line Pull (lbs.)	Rope Diameter (in.)	Winch Weight (lbs.)	Gross Weight (lbs.)	Rope Length (ft.)	Rope Included	Remote Included	Packaging	Master Carton
500630	12V DC, 0.8 KW, 1.1 HP	2,500 (1134 kg)	3/16 (4.8 mm)	20.5 (9.3 kg)	24.4 (11.1 kg)	46 (14.02 m)	Yes	Yes	Boxed	1
500631	12V DC, 1.0 KW, 1.3 HP	3,500 (1587 kg)	3/16 (4.8 mm)	22.0 (10.0 kg)	25.2 (11.4 kg)	46 (14.02 m)	Yes	Yes	Boxed	1
500632	12V DC, 1.1 KW, 1.4 HP	4,500 (2041 kg)	15/64 (6.0 mm)	33.3 (15.1 kg)	36.3 (16.5 kg)	48 (14.63 m)	Yes	Yes	Boxed	1

UTILITY WINCHES

BULLDOG™ Utility Duty Winches are compact, lightweight, and flexible, yet they're sturdy tools capable of handling a wide variety of applications with ease. They're always reliable and ready for action when you need to load a trailer, position cargo, or move a vehicle.

- Power in and power out for powerful retraction and rapid rope payout
- High-torque permanent magnet motor for a higher pull at a lower amp
- 3-stage planetary gearbox for reliable performance in tough conditions
- Lift or lower clutch lever for easy transition between gear engagement and free spooling
- Dual brakes include both automatic load-holding mechanical brake and slip-free motor dynamic brake for sure, confident control without slippage
- Integrated contactor assembly
- Circuit breakers automatically shut off the winch to prevent motor overheating



500400



500600

Part Number	Motor	Rated Line Pull (lbs.)	Rope Diameter (in.)	Winch Weight (lbs.)	Gross Weight (lbs.)	Rope Length (ft.)	Rope Included	Remote Included	Packaging	Master Carton
500400	12V DC, 600 W, 0.8 HP	2,500 (1133 kg)	3/16 (4.8 mm)	27.44 (12.0 kg)	37.2 (16.0 kg)	50 (15.24 m)	Yes	Yes	Litho Box	1
500401	12V DC, 900 W, 1.2 HP	3,500 (1587 kg)	7/32 (5.5 mm)	27.44 (12.0 kg)	37.2 (16.0 kg)	50 (15.24 m)	Yes	Yes	Litho Box	1
500402	12V DC, 1200 W, 1.6 HP	4,500 (2041 kg)	1/4 (6.3 mm)	27.44 (12.0 kg)	37.2 (16.0 kg)	50 (15.24 m)	Yes	Yes	Litho Box	1
500600**	12V DC, 4.63 KW, 5.8 HP	9,000 (4082 kg)	21/64 (8.3 mm)	84.40 (38.3 kg)	88.85 (40.3 kg)	95 (28.96 m)	Yes	Yes	Boxed	1
500601**	12V DC, 5.40 KW, 7.2 HP	12,000 (5443 kg)	13/32 (10.2 mm)	96.60 (43.8 kg)	101.00 (45.8 kg)	84 (25.60 m)	Yes	Yes	Boxed	1

*Limited lifetime warranty on mechanical parts. One year warranty on electrical components.

**Limited 1 year warranty



HEAVY DUTY WINCHES

BULLDOG™ Heavy Duty Winches are the right choice for big jobs and unforgiving conditions. They're fast, powerful, and tough. Built to BULLDOG™ Tough and Trusted standards using tough aluminum alloy housings, silver-alloy contact pads, and thick copper buss bars, they're weather resistant, and backed by a limited lifetime warranty covering all mechanical components.



- Patented automatic, full load Cone Brake Structure (CBS) uses "brake outside the drum" technology to rapidly disperse heat, protecting the winch and the rope
- Rugged, quiet, hardened steel 3-stage planetary gear train for reliable, durable performance in tough conditions and maximum mechanical efficiency
- Heavy duty sealed contactor for sound, waterproof protection
- Heavy duty motor is extremely durable and delivers superior torque output and faster line speed
- Thermometric sensor provides overheating indication
- Industrial grade waterproof remote includes LED overheating indicator
- Pull-and-turn T-handle clutch lever for easy transition between gear engagement and free spooling
- SAE J706 Compliant

Part Number	Motor	Rated Line Pull (lbs.)	Gear Ratio	Drum Size (in.)	Rope Diameter (in.)	Winch Weight (lbs.)	Gross Weight (lbs.)	Rope Length (ft.)	Rope Included	Remote Included	Packaging	Master Carton
500423	12V DC, 2390 W, 3.2 HP	6,000 (2722 kg)	216:1	2.5 x 4.9 (635 mm x 125.5 mm)	9/32 (7.1 mm)	33.2 (15.1 kg)	44 (20.0 kg)	70 (21.3 m)	Yes	No	Litho Box	1
500403	12V DC, 2390 W, 3.2 HP	6,000 (2722 kg)	216:1	2.5 x 4.9 (635 mm x 125.5 mm)	9/32 (7.1 mm)	33.2 (15.1 kg)	44 (20.0 kg)	-	No	No	Boxed	1
500424	12V DC, 3430 W, 4.6 HP	9,000 (4082 kg)	156:1	2.5 x 9.0 (63.5 mm x 229 mm)	3/8 (9.5 mm)	53 (24.1 kg)	78 (35.5 kg)	82 (24.9 m)	Yes	No	Litho Box	1
500404	12V DC, 3430 W, 4.6 HP	9,000 (4082 kg)	156:1	2.5 x 9.0 (63.5 mm x 229 mm)	3/8 (9.5 mm)	53 (24.1 kg)	78 (35.5 kg)	-	No	No	Boxed	1
500426	12V DC, 3430 W, 4.6 HP	12,000 (5443 kg)	211:1	2.5 x 9.0 (63.5 mm x 229 mm)	3/8 (9.5 mm)	59 (26.8 kg)	88 (40.0 kg)	88 (26.8 m)	Yes	No	Litho Box	1
500405	12V DC, 3430 W, 4.6 HP	12,000 (5443 kg)	211:1	2.5 x 9.0 (63.5 mm x 229 mm)	3/8 (9.5 mm)	59 (26.8 kg)	88 (40.0 kg)	-	No	No	Boxed	1
500406	12V DC, 4180 W, 5.6 HP	12,000 (5443 kg)	261:1	3.5 x 8.1 (89 mm x 206 mm)	3/8 (9.5 mm)	88 (40.0 kg)	118 (53.6 kg)	-	No	No	Boxed	1
500407	12V DC, 4180 W, 5.6 HP	15,000 (6804 kg)	315:1	3.5 x 8.1 (89 mm x 206 mm)	7/16 (11.1 mm)	90 (41.0 kg)	120 (54.5 kg)	-	No	No	Boxed	1
500408	24V DC, 4474 W, 6.0 HP	18,000 (8181 kg)	315:1	3.5 x 7.6 (89 mm x 192 mm)	1/2 (12.7 mm)	93 (42.3 kg)	124 (56.4 kg)	-	No	No	Boxed	1
Replacement Parts												
500532	Tie Rod Kit for 6K Winches										Poly Bag	1
500533	Tie Rod Kit for 9K and 12K Winches										Poly Bag	1
500534	Tie Rod Kit for 12K, 15K and 18K Winches										Poly Bag	1
500545	Contactor Kit for 6K Winches										Boxed	1
500546	Contactor for 9K, 12K and 15K Winches										Boxed	1

*Limited lifetime warranty on mechanical parts. One year warranty on electrical components.

NOTE: All BULLDOG Electric Winches are CE compliant with Machinery Directive 2006/42/EC and Electromagnetic Compatibility Directive 2004/108/EC





500413



500415

HYDRAULIC WINCHES

BULLDOG™ Hydraulic Winches are cost effective, extremely powerful, reliable, lightweight, and flexible winches designed for professional and commercial use. They're hard-working winches ready for rescue and recovery operations in tough situations.



- Fast and variable recovery speeds save time
- Efficient, high-torque motor provides consistent power
- 2-stage planetary gear train delivers greater pulling force
- Ergonomic pull-and-turn T-handle clutch lever for easy transition between gear engagement and free spooling
- Dual brakes include both drag brake and over-center valve for sure, confident control
- EN 14492-1 supported: 10:1 D/d ratio and 2:1 wire rope strength for high-demand use
- SAE J706 Compliant

Part Number	Motor	Rated Line Pull (lbs.)	Gear Ratio	Drum Size (in.)	Rope Diameter (in.)	Winch Weight (lbs.)	Gross Weight (lbs.)	Strap Included	Rope Included	Remote Included	Packaging	Master Carton
500413	4.7 in ³ / rev 77.8 cm ³ / rev	8,000 (3630 kg)	16:1	3.5 (90 mm)	3/8 (9.5 mm)	82.7 (37.5 kg)	99.9 (45.3 kg)	No	No	No	Boxed	1
500414	7.6 in ³ / rev 125.0 cm ³ / rev	12,000 (5440 kg)	16:1	4.0 (102 mm)	1/2 (12.7 mm)	81.4 (37.0 kg)	102.5 (72.0 kg)	No	No	No	Boxed	1
500415	7.6 in ³ / rev 125.0 cm ³ / rev	15,000 (6800 kg)	19:4:1	4.0 (102 mm)	1/2 (12.7 mm)	158.7 (72.0 kg)	194.0 (88.0 kg)	No	No	No	Boxed	1

*Limited lifetime warranty on mechanical parts. One year warranty on electrical components.

NOTE: All BULLDOG Hydraulic Winches are CE compliant with Machinery Directive 2006/42/EC and EN 14492-1:2006 Power Driven Winches



500410



500411

ELECTRIC HOISTS

BULLDOG™ Electric Hoists are cost effective, extremely powerful, reliable, lightweight, and flexible. Designed for professional and commercial use, ready for lowering and lifting the heaviest loads.



- Lightweight and compact design
- Sealed permanent magnet motor
- Equipped with patented mechanical cone brake with permanent dynamic motor brakes for controlled lowering and lifting
- Full metal 3-stage planetary gear train
- Submersible sealed contactor handles high amps and allows for longer duty cycle
- SAE J706 Compliant

Part Number	Motor	Rated Line Pull (lbs.)	Gear Ratio	Drum Size (in.)	Rope Diameter (in.)	Winch Weight (lbs.)	Gross Weight (lbs.)	Strap Included	Rope Included	Remote Included	Packaging	Master Carton
500410	12V DC, 800 W, 1.0 HP	625 (295 kg)	138:5:1	2.4 x 3.0 (61 mm x 76 mm)	9/64 (3.6 mm)	17.0 (7.7 kg)	25.6 (11.6 kg)	No	No	Switch	Boxed	1
500411	12V DC, 800 W, 1.0 HP	800 (362 kg)	191:1	2.7 x 4.7 (69 mm x 119 mm)	5/32 (4.0 mm)	18.3 (8.3 kg)	26.9 (12.2 kg)	No	No	Switch	Boxed	1
500412	12V DC, 900 W, 1.2 HP	1,200 (544 kg)	216:1	3.5 x 2.9 (89 mm x 74 mm)	3/16 (4.8 mm)	33.7 (15.3 kg)	44.5 (20.0 kg)	No	No	Switch	Boxed	1
Replacement Part												
500545	Contactor Kit										Boxed	1

*Limited lifetime warranty on mechanical parts. One year warranty on electrical components.

NOTE: All BULLDOG Electric Hoists are CE compliant

ATV / UTILITY WINCH ACCESSORIES



500527



500554



500517



500603



500540



500553

Part Number	Description	Packaging	Master Carton
500527	3-Pin Wireless Remote	Clamshell	10
500529	Wired Remote	Poly Bag	10
500539	Roller Fairlead, 63mm	Boxed	24
500549	Recovery Dampener	Poly Bag	20
500554	Tree Saver Kit, Includes: (1) Tree Saver Strap, (1 Pair) Gloves, (1) Snatch Block and (1) Clevis, 9K	Boxed	5
500602	Snatch Block, 9K	Boxed	20
500604	Bow Clevis, 4.75 Ton	Boxed	25
500605	"D" Clevis, 4.75 Ton	Boxed	25
500606	Quick Disconnect, 50 amp	Boxed	100
500607	Quick Disconnect, 175 amp	Boxed	50
500608	Synthetic Rope, 10mm x 100'	Display Bag	6
500609	Synthetic Rope, 6mm x 50'	Display Bag	25
500520	Galvanized Aircraft Wire Rope, A7 x 19, 3/8" x 82'	Bulk	3
6495	Winch Mounting Plate, 9K	Bulk	1
500553	Winch Mount, 9K	Litho Box	1

HEAVY DUTY / HYDRAULIC WINCH AND HOIST ACCESSORIES

Part Number	Description	Packaging	Master Carton
500526	6-Pin Wireless Remote	Clamshell	10
500527	3-Pin Wireless Remote	Clamshell	10
500528	3-Pin Wired Remote	Poly Bag	10
500530	6-Pin Wired Remote	Poly Bag	10
500516	Wire Rope, 5/16" x 70'	Bulk	4
500517	Synthetic Rope, 8mm x 80'	Poly Bag	5
500608	Synthetic Rope, 10mm x 100'	Poly Bag	6
500520	Galvanized Aircraft Wire Rope, A7 x 19, 3/8" x 82'	Bulk	3
500522	Galvanized Aircraft Wire Rope, A7 x 19, 3/8" x 125'	Bulk	3
500524	Hawse Fairlead, 112mm	Poly Bag	26
500525	Hawse Fairlead, 184mm	Poly Bag	29
500536	Cable Tensioner	Boxed	2
500540	Roller Fairlead, 190mm	Boxed	6
500541	Roller Fairlead, 210mm	Boxed	3
500542	Roller Fairlead, 180mm	Boxed	3
500549	Recovery Dampener	Poly Bag	15
500554	Tree Saver Kit, Includes: (1) Tree Saver Strap, (1 Pair) Gloves, (1) Snatch Block and (1) Clevis, 9K	Boxed	5
500602	Snatch Block, 9K	Boxed	20
500603	Snatch Block, 15K	Boxed	10
500604	Bow Clevis, 4.75 Ton	Boxed	25
500605	"D" Clevis, 4.75 Ton	Boxed	25
500607	Quick Disconnect, 175 amp	Boxed	50
6495	Winch Mounting Plate, 9K	Bulk	1
500553	Winch Mount, 9K	Litho Box	1



TRAILER LIGHTING

In 1934 the Wesbar® family of vehicle lighting and electrical products made its debut. Since that time, the brand has been a key ingredient to the success of some of the world's most legendary agricultural and industrial manufacturers. With offerings of both incandescent and LED lighting for vehicles and trailers, plus an extensive line of 12 volt electrical connection products, Wesbar® has continued to provide an all-encompassing selection of options for agricultural, industrial, marine, recreation and utility manufacturers. Wesbar® products are made waterproof, sealed, submersible and shock-resistant; everything you would expect when working in extreme environments.

LED TAIL LIGHTS

- LED Tail Light Module Kits M-3
- LED Single Tail Lights M-4
- LED Narrow Tail Lights M-4
- LED Double Tail Lights M-5 - M-6
- LED Triple Tail Lights M-5 - M-7
- Waterproof LED Tail Lights M-8 - M-12
- Submersible LED Tail Lights M-11 - M-12

TAIL LIGHTS

- Single Tail Lights M-13
- Double Tail Lights M-14
- Triple Tail Lights M-15
- Surface Mount Tail Lights M-16
- Combination Tail Lights M-17 - M-18
- Pedestal Mount Tail Lights M-17
- Magnetic Tow Light Kits M-18
- Waterproof Tail Lights M-19 - M-21
- Submersible Tail Lights M-21 - M-22

LED CLEARANCE/SIDE MARKER LIGHTS

- LED Waterproof Courtesy Lights M-23
- Waterproof LED Side Marker Lights M-23 - M-26
- LED Fender Lights M-24
- LED Side Marker Lights M-27 - M-29

CLEARANCE/SIDE MARKER LIGHTS

- Waterproof Courtesy Lights M-22 - M-23
- Waterproof Side Marker Lights M-29 - M-32
- Side Marker Lights M-33 - M-36
- Dual Bulb Side Marker Lights M-35

ID LIGHT BARS

- Waterproof ID Light Bars M-38 - M-39
- LED ID Light Bars M-38

AUXILIARY LIGHTS

- License Plate Lights M-39 - M-41
- Reflectors M-41 - M-42
- Utility Lights M-42 - M-43
- Interior Lights M-43 - M-44
- LED Work Lights M-12
- Bulbs M-44

AGRICULTURAL LIGHTS

- LED Heavy Duty AG Lights M-46
- LED Economy AG Lights M-47
- LED Pedestal Mount AG Lights M-47
- Heavy Duty AG Light Kits M-48
- Economy AG Light Kits M-49

FEATURED

LED SURFACE MOUNT DOUBLE TAIL LIGHTS #84 / #85 SERIES

- These LED double lights are available for surface mounting in vertical or horizontal applications
- Stylish bases with radius corners come in either black or chrome plated finish
- All lenses meet FMVSS/CMVSS 108 requirements
- Reflex is included on backup lens
- Pre-wired (supply and ground) for easy installation
- See page M-5 for additional information



WATERPROOF LED OVER 80 IN. WRAP-AROUND TAIL LIGHTS

- Waterproof surface mount tail lights
- Wrap-around design eliminates the need for rear side marker
- These lights meet FMVSS/CMVSS 108 requirements
- Plug-in 12 in. harness with 2-Way flat connector and ring terminal ground wire
- Stainless steel mounting hardware included
- See page M-8 for additional information



WATERPROOF/SEALED RECESSED TAIL LIGHTS #06 SERIES

- Oval design allows for installation in narrower channels
- Hermetically sealed lens prevents corrosion from salt and rain
- Structurally immune to extreme heat and cold
- Lenses meet FMVSS/CMVSS 108 requirements
- 6-1/2 in. x 2-1/4 in. x 2-3/8 in. depth
- Cutout: 6-3/4 in. x 2-1/2 in.
- See page M-21 for additional information





LED MODULE KITS #84/85/86 SERIES TAIL LIGHTS

- LED module kit for existing #84 series tail lights
- Remove the bulb and lens, replace with new LED module and instantly have LED red stop/tail/turn lights, amber turn lights, clear backup lights or clear backup with reflex lights
- Installation can be completed in minutes with only a screwdriver required

Part Number	Description	Brand	Packaging	Master Carton
42-84-410	LED Stop/Tail/Turn Light Lens Module Red with Bulb Socket Plug	Bargman	Clamshell	6
47-84-410	LED Stop/Tail/Turn Light Lens Module Red with Bulb Socket Plug	Bargman	Display Bag	25
42-84-412	LED Turn Light Lens Module Amber with Bulb Socket Plug	Bargman	Clamshell	6
47-84-412	LED Turn Light Lens Module Amber with Bulb Socket Plug	Bargman	Display Bag	25
47-84-026	LED Backup Light Lens Module Clear with Bulb Socket Plug, Lens Mounted Vertical	Bargman	Bulk	50

ENHANCED HEIGHT INCANDESCENT LENS #84/85/86 SERIES TAIL LIGHTS

- Enhanced height incandescent backup lens only for #84/85/86 series tail lights



Part Number	Description	Brand	Packaging	Master Carton
47-84-711	Enhanced Height Incandescent Backup Lens Only, Red Reflex with Clear Center, Red Border	Bargman	Bulk	100
48-84-711	Enhanced Height Incandescent Backup Lens Only, Red Reflex with Clear Center, Red Border	Bargman	Display Bag	25
47-85-711	Enhanced Height Incandescent Backup Lens Only, Red Reflex with Clear Center, Chrome Border	Bargman	Bulk	100
47-84-712	Enhanced Height Incandescent Lens Only, Red Reflex with Red Center, Red Border	Bargman	Bulk	100

LED MODULE KIT #86 SERIES WRAP-AROUND CLEARANCE/SIDE MARKER LIGHTS

- LED module kit for existing #86 series wrap-around clearance/side marker lights
- Remove and discard only the wedge base socket and bulb, replace with a new LED module and instantly have LED clearance/side marker lights

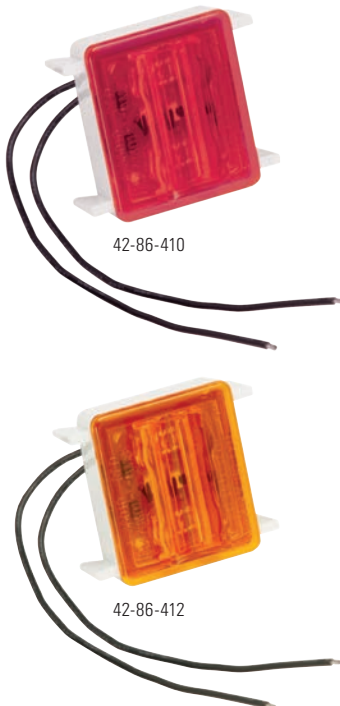

Part Number	Description	Brand	Packaging	Master Carton
42-86-410	LED Wrap-Around Clearance Light Module, Red	Bargman	Clamshell	12
42-86-412	LED Wrap-Around Clearance Light Module, Amber	Bargman	Clamshell	12

NOTE: Tail Lights, Clearance/Side Marker Lights and ID Light Bars approved for trailer accessory and towing application use. Contact your Horizon Global Representative for details.



LED SINGLE TAIL LIGHT #86 SERIES

- Meets FMVSS/CMVSS 108 requirements
- All include 16 gauge supply and ground wiring
- 5-13/16 in. x 4-3/8 in. x 2-7/8 in.

Part Number	Description	Brand	Packaging	Master Carton
47-86-101	LED Stop/Tail/Turn with Black Base	Bargman	Bulk	10
42-86-101	LED Stop/Tail/Turn with Black Base	Bargman	Clamshell	6
48-86-101	LED Stop/Tail/Turn with Black Base	Bargman	Bulk	40
Replacement Parts				
47-84-420	LED Stop/Tail/Turn Light Lens Module Red with Wires	Bargman	Display Bag	25

LED NARROW TAIL LIGHT #54 SERIES

- Designed for narrow rail surface mounting, 3 diodes
- Built-in reflex reflectors and mounting holes with stainless steel grommets
- Meets FMVSS/CMVSS 108 requirements
- Pre-wired (supply and ground) for easy installation
- 15.84 in. x 2.29 in. - mounting holes on 14.49 in. centers



Part Number	Description	Brand	Packaging	Master Carton
47-54-001	Red Stop/Tail/Turn	Bargman	Bulk	50

LED NARROW RED TAIL LAMP

- Meets FMVSS/ CMVSS 108 requirements
- 14.1 in. x 1 in.



Part Number	Description	Brand	Packaging	Master Carton
54200-015	Narrow Red LED Low and High Function Tail Light	Wesbar	Bulk	100
54200-016	Chrome Bezel for #54200-015	Wesbar	Bulk	60

BARGMAN #84/85/86 LED LIGHTS

LED Tail Lights and Module Kit for the most popular RV Tail Light in the World! Purchase as fully-assembled complete tail lights for installation or purchase a LED Upgrade Module. The Module Kit will allow you to quickly and easily field upgrade your installed Bargman Model #84/85/86 Tail Lights or Model #86 Wrap-Around Marker/Clearance lights from Incandescent to LED.

MODULE KITS:

These kits are designed to allow RV and Trailer owners to upgrade their Bargman #84/ 85/86 Tail Lights or #86 Wrap-Around Marker/Clearance lights from Incandescent to LED - quickly and safely. Due to the many configurations of these Bargman light models, upgrade modules are sold to upgrade only one module at a time.

NOTE: For regulatory purposes, installation of any competitive LED Upgrade Module designed for the Bargman #84/85/86 Tail Lights will immediately void all warranty on the entire Bargman tail light.

#84 SERIES TAIL LIGHTS LED UPGRADE MODULES

The end-user will simply count the number of red stop/tail/turn lights, amber turn lights or backup lights on the vehicle and order the appropriate number of the desired LED upgrade modules. Then simply remove the incandescent lens and bulb and plug the LED module (LED circuit board with connector and lens) into the existing bulb socket and mount, with the existing screws, to the holes in the existing light base.

#86 SERIES MARKER LIGHT LED UPGRADE MODULE

The end-user will simply count the number of wrap-around clearance/side marker lights on the vehicle and order the appropriate number of the desired LED upgrade kits. Then simply remove the lens and bulb and plug the LED module (LED circuit board) into the existing bulb socket and re-install the existing lens.

HOW TO ORDER

Fully assembled units:

Fully assembled LED versions of the Bargman #84/85/86 tail lights and #86 wrap-around clearance/side marker lights are listed. For convenience and consistency, we have listed them in the same manner that we list the incandescent models. Please note that the part numbers for all LED versions begin with 42/47/48.

WARNING: All Bargman #84/85/86 Tail Lights and #86 Wrap-Around Marker/Clearance lights meet FMVSS/CMVSS 108 requirements. WHEN UPGRADING EXISTING LIGHTS FROM INCANDESCENT TO LED, TO RETAIN FMVSS/ CMVSS 108 REQUIREMENTS, SPECIAL CARE MUST BE GIVEN TO REPLACE EXISTING LENS (OR TO ASSEMBLE MODULE) WITH A LED MODULE THAT WILL PERFORM THE EXACT SAME FUNCTION.



47-84-610



47-85-611

LED SURFACE MOUNT DOUBLE TAIL LIGHTS #84/85 SERIES

- Available for surface mounting in vertical or horizontal applications
- Stylish bases with radius corners come in either black or chrome plated finish
- All lenses meet FMVSS/CMVSS 108 requirements
- Reflex is included on backup lens
- Pre-wired (supply and ground) for easy installation
- 10-1/4 in. x 7-1/4 in. x 1-7/8 in.

Part Number	Description	Brand	Packaging	Master Carton
47-84-610	LED Red Stop/Tail/Turn, LED Red Stop/Tail/Turn with Black Base	Bargman	Bulk	5
47-85-611	LED Red Stop/Tail/Turn, LED Red Stop/Tail/Turn with Chrome Base	Bargman	Bulk	20
Replacement Parts				
47-84-420	LED Stop/Tail/Turn Light Lens Module Red with Wires	Bargman	Display Bag	25

NOTE: Tail Lights, Clearance/Side Marker Lights and ID Light Bars approved for trailer accessory and towing application use. Contact your Horizon Global Representative for details.



47-84-103

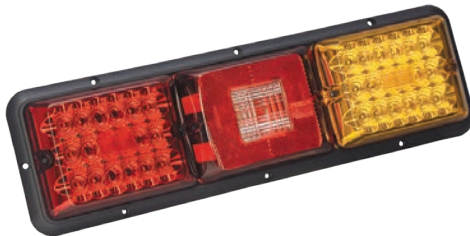

47-84-104



47-84-420

LED RECESSED TRIPLE LONG TAIL LIGHTS #84/85 SERIES

- Incorporates all of the features of the LED Recessed Triple Tail Light #84/85 series with a special lens placement that allows the light to be utilized for a narrow mounting
- Cutout: 16-1/8 in. x 3-5/8 in.
- Overall: 18 in. x 5-5/16 in. x 1-1/4 in. with 1 in. depth

Part Number	Description	Brand	Packaging	Master Carton
47-84-103	LED Red Stop/Tail/Turn, Incandescent Backup, LED Red Stop/Tail/Turn with Black Base	Bargman	Bulk	10
47-84-104	LED Red Stop/Tail/Turn, Incandescent Backup, LED Amber Turn with Black Base	Bargman	Bulk	10
Replacement Parts				
47-84-420	LED Stop/Tail/Turn Light Lens Module Red with Wires	Bargman	Display Bag	25
47-84-711	Enhanced Height Incandescent Backup Lens Only, Red Reflex with Clear Center, Red Border	Bargman	Bulk	100
48-84-711	Enhanced Height Incandescent Backup Lens Only, Red Reflex with Clear Center, Red Border	Bargman	Display Bag	25
47-84-712	Enhanced Height Incandescent Lens Only, Red Reflex with Red Center, Red Border	Bargman	Bulk	100

LED RECESSED DOUBLE TAIL LIGHTS #84/85 SERIES

- LED double lights for either vertical or horizontal mounting
- Radius corners
- Black, white and colonial white bases
- Clear LED or incandescent backup light lenses are surrounded by a Class "A" red reflex lens. Incandescent lens, red with red insert, is for clearance/side marker application only
- All lenses meet FMVSS/CMVSS 108 requirements
- Pre-wired (supply and ground) for easy installation
- Cutout: 8-7/16 in. x 5-1/2 in.
- Overall: 9-13/16 in. x 6-15/16 in. x 2-5/16 in. with 1 in. depth

47-84-527



47-84-001



47-84-540



47-84-008



47-84-529



47-84-808



Part Number	Description	Brand	Packaging	Master Carton
47-84-527	LED Red Stop/Tail/Turn, LED Red Stop/Tail/Turn with Black Base	Bargman	Bulk	5
48-84-527	LED Red Stop/Tail/Turn, LED Red Stop/Tail/Turn with Black Base	Bargman	Display Bag	5
47-84-001	LED Red Stop/Tail/Turn, Incandescent Backup with Colonial White Base	Bargman	Bulk	5
47-84-540	LED Red Stop/Tail/Turn, Incandescent Backup with White Base	Bargman	Bulk	5
47-84-008	LED Red Stop/Tail/Turn, Incandescent Backup with Black Base	Bargman	Bulk	5
48-84-008	LED Red Stop/Tail/Turn, Incandescent Backup with Black Base	Bargman	Display Bag	5
47-84-529	LED Red Stop/Tail/Turn, Incandescent Red with Red Insert (Clearance/Side Marker Application Only) with Black Base	Bargman	Bulk	5
47-84-808	LED Red Stop/Tail/Turn, Incandescent Backup with Black Base, 12" 4/Conductor Cord with 4-Way Square Connector	Bargman	Bulk	20
Replacement Parts				
47-84-420	LED Stop/Tail/Turn Light Lens Module Red with Wires	Bargman	Display Bag	25
47-84-711	Enhanced Height Incandescent Backup Lens Only, Red Reflex with Clear Center, Red Border	Bargman	Bulk	100
48-84-711	Enhanced Height Incandescent Backup Lens Only, Red Reflex with Clear Center, Red Border	Bargman	Display Bag	25
47-84-712	Enhanced Height Incandescent Lens Only, Red Reflex with Red Center, Red Border	Bargman	Bulk	100

NOTE: Tail Lights, Clearance/Side Marker Lights and ID Light Bars approved for trailer accessory and towing application use. Contact your Horizon Global Representative for details.



47-84-530



47-84-009



47-85-002



47-84-005



47-85-004

LED RECESSED TRIPLE TAIL LIGHTS #84/85 SERIES

- LED triple lights for either vertical or horizontal mounting
- Radius corners
- Bases in black, white, colonial white and chrome plated finish
- Clear LED or incandescent backup light lenses surrounded by a Class "A" red reflex lens
- Incandescent lens, red with red insert, for clearance/side marker application only
- Lenses meet FMVSS/CMVSS 108 requirements
- Pre-wired (supply and ground) for easy installation
- Cutout: 12-11/16 in. x 5-1/2 in.
- Overall: 14-1/16 in. x 6-15/16 in. x 1-1/4 in. with 1 in. depth

Part Number	Description	Brand	Packaging	Master Carton
47-84-530	LED Red, LED Red Stop/Tail/Turn, Incandescent Backup with White Base	Bargman	Bulk	5
48-84-009	LED Red, LED Red Stop/Tail/Turn, Incandescent Backup with Black Base	Bargman	Display Bag	5
47-84-009	LED Red, LED Red Stop/Tail/Turn, Incandescent Backup with Black Base	Bargman	Bulk	5
47-85-002	LED Red, LED Red Stop/Tail/Turn, Incandescent Backup with Chrome Base	Bargman	Bulk	5
47-84-005	LED Red Stop/Tail/Turn, LED Amber Turn, Incandescent Backup with Black Base	Bargman	Bulk	5
47-85-004	LED Red Stop/Tail/Turn, LED Amber Turn, Incandescent Backup with Chrome Base	Bargman	Bulk	10
Replacement Parts				
47-84-420	LED Stop/Tail/Turn Light Lens Module Red with Wires	Bargman	Display Bag	25
47-84-711	Enhanced Height Incandescent Backup Lens Only, Red Reflex with Clear Center, Red Border	Bargman	Bulk	100
48-84-711	Enhanced Height Incandescent Backup Lens Only, Red Reflex with Clear Center, Red Border	Bargman	Display Bag	25
47-84-712	Enhanced Height Incandescent Lens Only, Red Reflex with Red Center, Red Border	Bargman	Bulk	100

NOTE: Tail Lights, Clearance/Side Marker Lights and ID Light Bars approved for trailer accessory and towing application use. Contact your Horizon Global Representative for details.



271574



271575



407540

WATERPROOF LED OVER 80 IN. 3X8 LOW PROFILE TAIL LIGHTS



- Meets FMVSS/CMVSS 108 requirements for trailers over 80 in. wide when properly mounted
- Includes stainless steel mounting hardware
- Includes 3-Wire plug-in harness with 12 in. wire leads and 7 in. ring terminal ground
- Kit comes complete with two low profile tail lights, 25 ft. trailer wiring harness cable with molded 4-Way plug, 4 ft. 4-Wire car wiring harness cable with molded 4-Way plug and license plate bracket
- 8 in. x 3.5 in. x 3 in.

Part Number	Description	Brand	Packaging	Master Carton
271574	7-Function, Right/Curbside	Wesbar	Bulk	24
407530	7-Function, Right/Curbside	Wesbar	Bulk	24
271575	8-Function, Left/Roadside	Wesbar	Bulk	24
407535	8-Function, Left/Roadside	Wesbar	Bulk	24
31-407540	Trailer Light Kit	Bargman	Bulk	12
407540	Trailer Light Kit	Wesbar	Clamshell	3
Replacement Parts				
40-00-004	3 Wire 90° Pigtail with 12" Wire Lead	Bargman	Poly Bag	100
719063	3 Wire 90° Pigtail with 12" Wire Lead	Wesbar	Poly Bag	12
003201	License Plate Bracket	Wesbar	Bulk	200
003211	License Plate Bracket	Wesbar	Display Bag	24
54504-001	Protective Tail Light Bracket	Wesbar	Bulk	36
002301	4' Wiring Harness with 4-Way Flat Car End	Wesbar	Bulk	300
707275	4' Wiring Harness with 4-Way Flat Car End	Wesbar	Clamshell	6
108825	25' Wiring Harness with 4-Way Flat Trailer End	Wesbar	Bulk	50
707261	25' Wiring Harness with 4-Way Flat Trailer End	Wesbar	Clamshell	6



271594



271595



WATERPROOF LED OVER 80 IN. WRAP-AROUND TAIL LIGHTS



- Waterproof surface mount tail lights
- Wrap-around design eliminates the need for rear side marker
- Meets FMVSS/CMVSS 108 requirements
- Plug-in 12 in. harness with 2-Way flat connector and ring terminal ground wire
- Stainless steel mounting hardware included
- 7.53 in. x 3.48 in. x 3.13 in.

Part Number	Description	Brand	Packaging	Master Carton
271594	7-Function, Right/Curbside	Wesbar	Bulk	12
281594	7-Function, Right/Curbside	Wesbar	Clamshell	6
271595	8-Function, Left/Roadside	Wesbar	Bulk	12
281595	8-Function, Left/Roadside	Wesbar	Clamshell	6
281500	Wrap-Around Trailer Light Kit with 25' Wire Harness	Wesbar	Litho Box	2
Replacement Parts				
54504-001	Protective Tail Light Bracket	Wesbar	Bulk	36



WATERPROOF LED OVER 80 IN. 4X6 LOW PROFILE TAIL LIGHTS

- Unique, compact size and shape allows these waterproof lights to fit where space is limited
- Meets FMVSS/CMVSS 108 requirements for trailers over 80 in. wide when properly mounted
- Includes stainless steel mounting hardware
- Kit comes complete with two low profile tail lights, 25 ft. trailer wiring harness cable with molded 4-flat plug, 4 ft. 4-Wire car wiring harness cable with molded 4-flat plug and license plate bracket
- 6 in. x 3-1/2 in. x 2-1/4 in.

271584



271585



407560

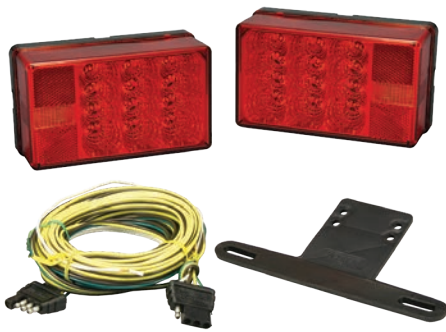

Part Number	Description	Brand	Packaging	Master Carton
271584	7-Function, Right/Curbside	Wesbar	Bulk	12
271584-01	7-Function, Right/Curbside with 3 Wire Pigtail	Wesbar	Bulk	12
407550	7-Function, Right/Curbside with 3 Wire 90° Pigtail	Wesbar	Clamshell	3
271585	8-Function, Left/Roadside	Wesbar	Bulk	12
271585-01	8-Function, Left/Roadside with 3 Wire Pigtail	Wesbar	Bulk	12
407555	8-Function, Right/Curbside with 3 Wire 90° Pigtail	Wesbar	Clamshell	3
31-407560	Trailer Light Kit	Bargman	Bulk	12
407560	Trailer Light Kit	Wesbar	Clamshell	3
Replacement Parts				
40-00-004	3 Wire 90° Pigtail with 12" Wire Lead	Bargman	Poly Bag	100
719063	3 Wire 90° Pigtail with 12" Wire Lead	Wesbar	Poly Bag	12
003201	License Plate Bracket	Wesbar	Bulk	200
003211	License Plate Bracket	Wesbar	Display Bag	24
54504-001	Protective Tail Light Bracket	Wesbar	Bulk	36
002301	4' Wiring Harness with 4-Way Flat Car End	Wesbar	Bulk	300
707275	4' Wiring Harness with 4-Way Flat Car End	Wesbar	Clamshell	6
108825	25' Wiring Harness with 4-Way Flat Trailer End	Wesbar	Bulk	50
707261	25' Wiring Harness with 4-Way Flat Trailer End	Wesbar	Clamshell	6

47-01-031



54200-012



54200-018



WATERPROOF LED 4 IN. ROUND TAIL LIGHTS



- Meets FMVSS/CMVSS 108 requirements

Part Number	Description	Brand	Packaging	Master Carton
47-01-031	Red Stop/Tail/Turn Light with Grommet with Pigtail	Bargman	Display Bag	25
54200-012	Clear Lens LED Tail Lamp with Mounting Flange	Bargman	Bulk	100
54200-013	Clear Lens LED Tail Lamp with Mounting Flange	Bargman	Blister Card	36
54200-018	Amber Lens LED Turn Lamp	Wesbar	Bulk	10
Replacement Parts				
47-01-001	Stop/Tail/Turn Light 4" Round Red	Bargman	Bulk	10
40-00-006	Pigtail	Bargman	Bulk	100
40-01-020	4" Round Grommet	Bargman	Bulk	50

54004



50-767751



40-767758



WATERPROOF LED 6 IN. OVAL SURFACE FLANGE MOUNT TAIL LIGHTS

- Featuring LED Technology
- Waterproof
- Meets FMVSS/CMVSS 108 requirements
- Surface mounting with pre-wired supply and ring terminal ground for easy installation
- 7.50 in. x 3.28 in. x 0.82 in.



Part Number	Description	Brand	Packaging	Master Carton
54004	Red Stop/Tail/Turn with Black Flange with Chrome Trim Snap Ring	Wesbar	Clamshell	6
50-767751	Red Stop/Tail/Turn with Black Flange	Bargman	Bulk	10
50-767752	Red Supplemental Center High Mount Stop Lamp with Black Flange	Bargman	Bulk	10
40-767758	Amber Turn with Black Flange	Wesbar	Bulk	10
Replacement Parts				
85-767010	Chrome Trim Snap Ring	Bargman	Bulk	20

NOTE: Tail Lights, Clearance/Side Marker Lights and ID Light Bars approved for trailer accessory and towing application use. Contact your Horizon Global Representative for details.

47-06-034



47-06-004



401591



108119



WATERPROOF LED 6 IN. OVAL GROMMET MOUNT TAIL LIGHTS

- Featuring LED Technology
- Waterproof
- Meets FMVSS/CMVSS 108 requirements
- Lights are mounting-orientation specific
- Mounting bracket of 11 gauge steel available separately
- 6-1/2 in. x 2-5/16 in. x 7/8 in.



Part Number	Description	Brand	Packaging	Master Carton
47-06-034	Red Stop/Tail/Turn Light Horizontal Mount with Grommet with 90° Pigtail	Bargman	Display Bag	25
Replacement Parts				
47-06-004	Red Stop/Tail/Turn Light Horizontal Mount	Bargman	Bulk	100
47-06-404	Red Stop/Tail/Turn Light Horizontal Mount	Bargman	Display Bag	25
401584	Red Stop/Tail/Turn Light Horizontal Mount	Wesbar	Clamshell	3
40-00-003	3 Wire Pigtail with 12" Wire Lead	Bargman	Bulk	200
40-00-004	3 Wire 90° Pigtail with 12" Wire Lead	Bargman	Bulk	200
719063	3 Wire 90° Pigtail with 12" Wire Lead	Wesbar	Poly Bag	12
40-06-020	6" Oval Grommet	Bargman	Bulk	100
416088	6" Oval Grommet	Wesbar	Poly Bag	12
108119	6" Oval Mounting Bracket	Wesbar	Bulk	20
106873	6" Oval Mounting Bracket	Wesbar	Display Bag	12
401591	6" Oval Grommet and 3 Wire 90° Pigtail	Wesbar	Display Bag	24



Wet Location Lighting Products



SUBMERSIBLE LED UNDER 80 IN. COMBINATION TAIL LIGHTS

- Ideal for boat and PWC trailers less than 80 in. wide
- Meets FMVSS/CMVSS 108 requirements
- Stud mounted using 2 in. O.C. industry standard stud configuration
- Pre-wired (supply and ground) for easy installation, 5.12 in. x 4.50 in. x 1.85 in. with 0.86 in. depth
- Kit comes complete with two low profile tail lights, 25 ft. trailer wiring harness cable with molded 4-flat plug, 4 ft. four wire car wiring harness cable with molded 4-Way plug and license plate bracket

273006

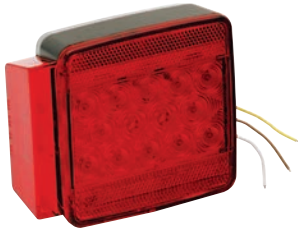

273056

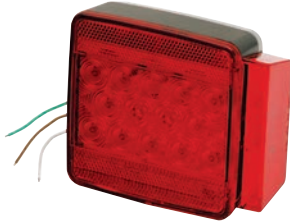

287512



Part Number	Description	Brand	Packaging	Master Carton
273006	7-Function, Left/Roadside	Wesbar	Bulk	50
283006	7-Function, Left/Roadside	Wesbar	Boxed	2
273056	6-Function, Right/Curbside	Wesbar	Bulk	50
283056	6-Function, Right/Curbside	Wesbar	Boxed	2
287512	Trailer Light Kit with 25' Wire Harness	Wesbar	Boxed	2
Replacement Parts				
54504-001	Protective Tail Light Bracket	Wesbar	Bulk	36

NOTE: Tail Lights, Clearance/Side Marker Lights and ID Light Bars approved for trailer accessory and towing application use. Contact your Horizon Global Representative for details.

WATERPROOF LED 6 IN. OVAL GROMMET MOUNT TAIL LIGHTS



- Featuring LED Technology
- 10 diodes
- Waterproof
- Meets FMVSS/CMVSS 108 requirements
- Approved for vertical or horizontal mounting
- Grommet, 3 prong wiring pigtail and 11 gauge steel mounting bracket available separately, 6.42 in. x 2.28 in. x 1 in.

54006



273561



273564



273565



Part Number	Description	Brand	Packaging	Master Carton
54006	Red Stop/Tail/Turn Light with Grommet with 3 Wire 90° Pigtail	Wesbar	Clamshell	6
273561	Red Stop/Tail/Turn Light	Wesbar	Bulk	20
283561	Red Stop/Tail/Turn Light	Wesbar	Clamshell	6
273564	Amber Turn Light	Wesbar	Bulk	20
283564	Amber Turn Light	Wesbar	Clamshell	6
273565	White Backup Light	Wesbar	Bulk	20
283565	White Backup Light	Wesbar	Clamshell	6
Replacement Parts				
40-00-003	3 Wire Pigtail with 12" Wire Lead	Bargman	Bulk	200
40-00-004	3 Wire 90° Pigtail with 12" Wire Lead	Bargman	Poly Bag	12
719063	3 Wire 90° Pigtail with 12" Wire Lead	Wesbar	Bulk	200
40-06-020	6" Oval Grommet	Bargman	Bulk	100
416088	6" Oval Grommet	Wesbar	Poly Bag	12
108119	6" Oval Mounting Bracket	Wesbar	Bulk	20
106873	6" Oval Mounting Bracket	Wesbar	Bulk	12
401591	6" Oval Grommet and 3 Wire 90° Pigtail	Wesbar	Bulk	100



SUBMERSIBLE LED OVER 80 IN. COMBINATION TAIL LIGHTS

- Ideal for boat and PWC trailers
- Meets FMVSS/CMVSS 108 requirements for trailers over 80 in. wide when properly mounted
- Stud mounted using 2 in. O.C. industry standard stud configuration
- Pre-wired (supply and ground) for easy installation, 5.48 in. x 4.50 in. x 1.85 in. with 0.86 in. depth

273008



273058



Part Number	Description	Brand	Packaging	Master Carton
273008	8 Function Left/Roadside	Wesbar	Bulk	6
273058	7 Function Right/Curbside	Wesbar	Bulk	6
283008	8 Function Left/Roadside	Wesbar	Boxed	2
283058	7 Function Right/Curbside	Wesbar	Boxed	2
283500	Trailer Light Kit with 25' Wire Harness	Wesbar	Boxed	2
Replacement Parts				
54504-001	Protective Tail Light Bracket	Wesbar	Bulk	36

LED WORK LIGHTS

- Perfect for exterior use in AG, horse, livestock, RV, industrial and racing applications
- Environmentally sealed design with aluminum housing and stainless steel mounting stud
- High power, true white 9-36V, 10W light emission
- Rectangular version with 10 LED diodes, circular model has 8 LED diodes
- Circular: 4.5 in. diameter x 1.50 in. depth
- Rectangular: 4 in. x 4 in. x 1.50 in. depth

54209-001



54209-025



Part Number	Description	Brand	Packaging	Master Carton
54209-001	Circular LED Light, 8 Diodes	Wesbar	Boxed	24
54209-002	Rectangular LED Light, 10 Diodes	Wesbar	Boxed	24
54209-025	Rectangular LED Light, 10 Diodes with Molded 2-Flat Plug	Wesbar	Boxed	24

LED WORK LIGHTS WITH COILED CORD AND MAGNETIC BASE

- Perfect for exterior use in AG, horse, livestock, RV, industrial and racing applications
- Environmentally sealed design with 19 ft. extended coiled cord
- Magnetic base, with protective film, secures in high vibration conditions in a vertical or horizontal position
- Power adapter for 12V outlet with separate on/off switch
- High power, true white 9-36V, 10W light emission
- Rectangular version with 10 LED diodes, circular model has 8 LED diodes
- Circular: 4.5 in. diameter x 1.875 in. depth
- Rectangular: 4 in. x 4 in. x 1.75 in. depth

54209-017



54209-018



Part Number	Description	Brand	Packaging	Master Carton
54209-017	Circular LED Light, with Cord, Magnetic Base, 8 Diodes	Wesbar	Boxed	2
54209-018	Rectangular LED Light, with Cord, Magnetic Base, 10 Diodes	Wesbar	Boxed	2

30-86-101



30-86-103



30-86-107

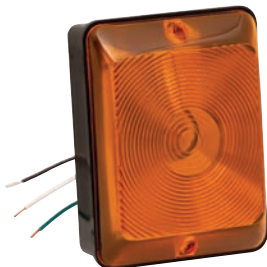

30-86-005



34-86-202



34-86-203



SINGLE SERIES TAIL LIGHTS #86 SERIES

- Meets FMVSS/CMVSS 108 requirements
- Backup light has a clear lens surrounded by a Class “A” reflector
- Bases are available in either white or black
- All include J-slot bayonet sockets for dependable flicker-free operation and 16 gauge supply and ground wiring
- 5-13/16 in. x 4-3/8 in. x 2-7/8 in.
- Cutout: 5-7/8 in. x 5-1/2 in.

Part Number	Description	Brand	Packaging	Master Carton
30-86-101	Red Stop/Tail/Turn with Black Base	Bargman	Bulk	10
31-86-101	Red Stop/Tail/Turn with Black Base	Bargman	Clamshell	6
34-86-101	Red Stop/Tail/Turn with Black Base	Bargman	Display Bag	25
30-86-103	Backup Vertical Mount with Black Base	Bargman	Bulk	10
31-86-103	Backup Vertical Mount with Black Base	Bargman	Clamshell	6
30-86-107	Amber Turn with Black Base	Bargman	Bulk	40
Replacement Parts				
30-90-156	Bulb #1156, Single Filament	Bargman	Bulk	1,000
30-84-057	Bulb #2057, Double Filament	Bargman	Bulk	1,000
31-84-010	Lens Red	Bargman	Clamshell	6
34-84-010	Lens Red	Bargman	Display Bag	25
31-84-016	Lens Amber	Bargman	Clamshell	6
34-84-016	Lens Amber	Bargman	Display Bag	25
31-84-700	Lens Backup - Lens Mounted Vertical	Bargman	Clamshell	6
34-84-700	Lens Backup - Lens Mounted Vertical	Bargman	Display Bag	25
31-84-711	Lens Backup - Lens Mounted Horizontal	Bargman	Clamshell	6
34-84-711	Lens Backup - Lens Mounted Horizontal	Bargman	Display Bag	25
30-84-075	Tail Light Lens Screw	Bargman	-	-

NOTE: Tail Lights, Clearance/Side Marker Lights and ID Light Bars approved for trailer accessory and towing application use. Contact your Horizon Global Representative for details.

WRAP-AROUND CLEARANCE/SIDE MARKER LIGHTS #86 SERIES

- Meets lighting requirements for side markers and clearance lights and doubles as a Class “A” side-reflex reflector
- The light meets FMVSS/CMVSS 108 requirements
- Bases are available in either white or black
- The molded socket with two wires protects bulb from road shock and the molded grommet protects the wiring
- 5-3/4 in. x 4-3/8 in. x 2-3/16 in.

Part Number	Description	Brand	Packaging	Master Carton
30-86-005†	Red with Colonial White Base	Bargman	Bulk	20
34-86-202	Red with Black Base	Bargman	Display Bag	5
34-86-203	Amber with Black Base	Bargman	Display Bag	5
Replacement Parts				
34-86-711	Lens #86 Red Wrap Around	Bargman	Display Bag	25
34-86-712	Lens #86 Amber Wrap Around	Bargman	Display Bag	25
30-84-075	Tail Light Lens Screw	Bargman	-	-

† = Available while supplies last

RECESSED DOUBLE TAIL LIGHTS

#84 SERIES

- Available for vertical or horizontal mounting
- Comes in black, white and colonial white
- Clear backup light lenses are surrounded by a Class "A" red reflex lens
- All lenses meet FMVSS/CMVSS 108 requirements
- All include J-slot bayonet sockets for dependable flicker-free operation and 16 gauge supply and ground wiring
- Cutout: 8-7/16 in. x 5-1/2 in.
- Overall: 9-13/16 in. x 6-15/16 in. x 1-1/4 in. with 1 in. depth

30-84-001



30-84-540



30-84-008



30-84-508



30-84-547



30-84-527



Part Number	Description	Brand	Packaging	Master Carton
30-84-001	Horizontal Mount with Red Stop/Tail/Turn, Backup Lens with Colonial White Base	Bargman	Bulk	20
30-84-540	Horizontal Mount with Red Stop/Tail/Turn, Backup Lens with White Base	Bargman	Bulk	20
30-84-008	Horizontal Mount with Red Stop/Tail/Turn, Backup Lens with Black Base	Bargman	Bulk	20
34-84-008	Horizontal Mount with Red Stop/Tail/Turn, Backup Lens with Black Base	Bargman	Display Bag	5
30-84-508	Vertical Mount with Red Stop/Tail/Turn, Backup Lens with Black Base	Bargman	Bulk	20
30-84-547	Red/Red Stop/Tail/Turn with White Base	Bargman	Bulk	20
30-84-527	Red/Red Stop/Tail/Turn with Black Base	Bargman	Bulk	20
34-84-527	Red/Red Stop/Tail/Turn with Black Base	Bargman	Display Bag	5
30-84-529	Red Stop/Tail/Turn, with Red Insert (Clearance/Side Marker Application Only) with Black Base	Bargman	Bulk	20
Replacement Parts				
30-90-156	Bulb #1156, Single Filament	Bargman	Bulk	1,000
30-84-057	Bulb #2057, Double Filament	Bargman	Bulk	1,000
31-84-010	Lens Red	Bargman	Clamshell	6
34-84-010	Lens Red	Bargman	Display Bag	25
31-84-016	Lens Amber	Bargman	Clamshell	6
34-84-016	Lens Amber	Bargman	Display Bag	25
31-84-700	Lens Backup - Lens Mounted Vertical	Bargman	Clamshell	6
34-84-700	Lens Backup - Lens Mounted Vertical	Bargman	Display Bag	25
31-84-711	Lens Backup - Lens Mounted Horizontal	Bargman	Clamshell	6
34-84-711	Lens Backup - Lens Mounted Horizontal	Bargman	Display Bag	25
34-85-750	Lens Red with Red Insert (Clearance/Side Marker Application Only)	Bargman	Display Bag	25
30-84-075	Tail Light Lens Screw	Bargman	-	-

NOTE: Tail Lights, Clearance/Side Marker Lights and ID Light Bars approved for trailer accessory and towing application use. Contact your Horizon Global Representative for details.

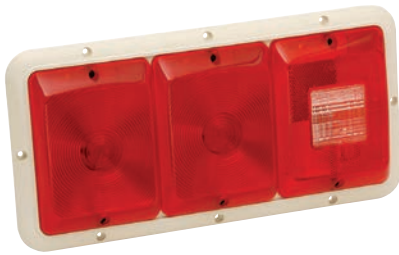

30-84-002

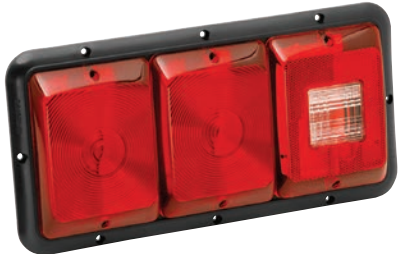

30-84-009

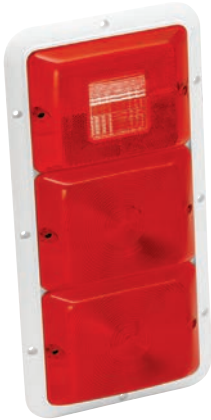

30-84-523



30-84-103



30-84-104

RECESSED TRIPLE TAIL LIGHTS #84/85 SERIES

- Available for either vertical or horizontal mounting
- Clear backup light lenses are surrounded by a Class "A" red reflex lens
- All lenses meet FMVSS/CMVSS 108 requirements
- All include J-slot bayonet sockets for dependable flicker-free operation and 16 gauge supply and ground wiring
- Cutout: 12-11/16 in. x 5-1/2 in.
- Overall: 14-1/16 in. x 6-15/16 in. x 1-1/4 in. with 1 in. depth

Part Number	Description	Brand	Packaging	Master Carton
30-84-002	Horizontal Mount with Red, Red Stop/Tail/Turn, Backup with Colonial White Base	Bargman	Bulk	20
30-84-009	Horizontal Mount with Red, Red Stop/Tail/Turn, Backup with Black Base	Bargman	Bulk	20
34-84-009	Horizontal Mount with Red, Red Stop/Tail/Turn, Backup with Black Base	Bargman	Display Bag	5
30-85-002	Horizontal Mount with Red, Red Stop/Tail/Turn, Backup with Chrome Base	Bargman	Bulk	20
30-84-523	Vertical Mount with Red, Red Stop/Tail/Turn, Backup with White Base	Bargman	Bulk	20
30-84-509	Vertical Mount with Red, Red Stop/Tail/Turn, Backup with Black Base	Bargman	Bulk	5

RECESSED TRIPLE LONG TAIL LIGHTS #84/85 SERIES

- Incorporates all of the features of the Recessed Triple Tail Light #84 Series / #85 Series with a special lens placement that allows the light to be utilized for a narrow mounting
- Cutout: 16-1/8 in. x 3-5/8 in.
- Overall: 18 in. x 5-5/16 in. x 1-1/4 in. with 1 in. depth

Part Number	Description	Brand	Packaging	Master Carton
30-84-103	Horizontal Mount Red Stop/Tail/Turn, Backup, Red Stop/Tail/Turn with Black Base	Bargman	Bulk	20
30-84-104	Horizontal Mount Red Stop/Tail/Turn, Backup, Amber Turn with Black Base	Bargman	Bulk	20
30-84-554	Vertical Mount Red Stop/Tail/Turn, Backup, Amber Turn with Black Base	Bargman	Bulk	20

Replacement Parts

30-90-156	Bulb #1156, Single Filament	Bargman	Bulk	1,000
30-84-057	Bulb #2057, Double Filament	Bargman	Bulk	1,000
31-84-010	Lens Red	Bargman	Clamshell	6
34-84-010	Lens Red	Bargman	Display Bag	25
31-84-016	Lens Amber	Bargman	Clamshell	6
34-84-016	Lens Amber	Bargman	Display Bag	25
31-84-700	Lens Backup - Lens Mounted Vertical	Bargman	Clamshell	6
34-84-700	Lens Backup - Lens Mounted Vertical	Bargman	Display Bag	25
31-84-711	Lens Backup - Lens Mounted Horizontal	Bargman	Clamshell	6
34-84-711	Lens Backup - Lens Mounted Horizontal	Bargman	Display Bag	25
34-85-750	Lens Red with Red Insert (Clearance/Side Marker Application Only)	Bargman	Display Bag	25
30-84-075	Tail Light Lens Screw	Bargman	-	-

SURFACE MOUNT TAIL LIGHTS #92 SERIES

- Available with or without backup lens
- Maximum design and replacement flexibility
- White or black bases
- All include automotive corrosion resistant bulb sockets and 16 gauge supply and ground wiring
- These lights meet FMVSS/CMVSS 108 requirements
- Easy installation and long life
- Designed for horizontal, surface mounting only
- 8-9/16 in. x 4-9/16 in. x 2-1/8 in.



30-92-106

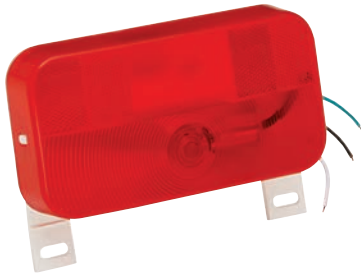

30-92-003



30-92-108



30-92-002

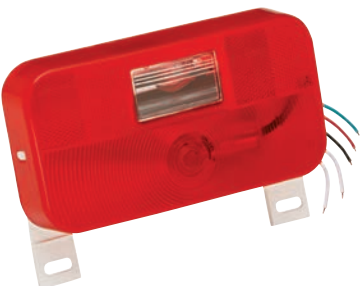

30-92-004



30-92-109

Part Number	Description	Brand	Packaging	Master Carton
30-92-001	Stop/Tail/Turn Light Surface Mount #92 with White Base	Bargman	Bulk	12
31-92-001	Stop/Tail/Turn Light Surface Mount #92 with White Base	Bargman	Clamshell	10
34-92-001	Stop/Tail/Turn Light Surface Mount #92 with White Base	Bargman	Display Bag	5
30-92-106	Stop/Tail/Turn Light Surface Mount #92 with Black Base	Bargman	Bulk	12
30-92-003	Stop/Tail/Turn Light Surface Mount #92 with License Light and Bracket with White Base	Bargman	Bulk	48
31-92-003	Stop/Tail/Turn Light Surface Mount #92 with License Light and Bracket with White Base	Bargman	Clamshell	10
34-92-003	Stop/Tail/Turn Light Surface Mount #92 with License Light and Bracket with White Base	Bargman	Display Bag	25
30-92-108	Stop/Tail/Turn Light Surface Mount #92 with License Light and Bracket with Black Base	Bargman	Bulk	12
30-92-002	Stop/Tail/Turn Light Surface Mount #92 with Backup with White Base	Bargman	Bulk	12
34-92-002	Stop/Tail/Turn Light Surface Mount #92 with Backup with White Base	Bargman	Display Bag	25
30-92-107	Stop/Tail/Turn Light Surface Mount #92 with Backup with Black Base	Bargman	Bulk	12
30-92-004	Stop/Tail/Turn Light Surface Mount #92 with Backup with License Light and Bracket with White Base	Bargman	Bulk	12
30-92-109	Stop/Tail/Turn Light Surface Mount #92 with Backup with License Light and Bracket with Black Base	Bargman	Bulk	12
30-92-044	Tail Light 15 Degree Wedge Base for #92 Series, White #7, 9" x 5 1/8" x 1 1/2"	Bargman	Bulk	25
Replacement Parts				
30-90-156	Bulb #1156, Single Filament	Bargman	Bulk	1,000
30-84-057	Bulb #2057, Double Filament	Bargman	Bulk	1,000
30-92-012	Lens for 30-92-001, 106	Bargman	Bulk	20
34-92-012	Lens for 30-92-001, 106	Bargman	Display Bag	25
30-92-704	Lens for 30-92-002, 107	Bargman	Bulk	20
34-92-704	Lens for 30-92-002, 107	Bargman	Display Bag	25
30-92-708	Lens for 30-92-003, 108	Bargman	Bulk	20
34-92-708	Lens for 30-92-003, 108	Bargman	Display Bag	25
30-92-713	Lens for 30-92-004, 109	Bargman	Bulk	20
34-92-713	Lens for 30-92-004, 109	Bargman	Display Bag	25

NOTE: Tail Lights, Clearance/Side Marker Lights and ID Light Bars approved for trailer accessory and towing application use. Contact your Horizon Global Representative for details.



2423293



2423294

COMBINATION OVER 80 IN. TAIL LIGHTS #80 SERIES

- Universal 2 in. on center stud mounting
- Screw-on main and side marker lens allow for easy bulb replacement
- Meets FMVSS/CMVSS 108 requirements for trailers over 80 in. wide when properly mounted
- Wiring uses the quick connect and disconnect feature
- 6.09 in. x 4.59 in. x 2.87 in.

Part Number	Description	Brand	Packaging	Master Carton
2423293	8-Function, Left/Roadside	Wesbar	Bulk	10
2823293	8-Function, Left/Roadside	Wesbar	Clamshell	6
2423294	7-Function, Right/Curbside	Wesbar	Bulk	10
2823294	7-Function, Right/Curbside	Wesbar	Clamshell	6
Replacement Parts				
108891	Bulb #193	Wesbar	Bulk	5,000
30-90-157	Bulb #1157, Double Filament	Wesbar	-	-
2423286	Lens, Tail Light	Wesbar	Bulk	100
2423287	Lens, Red, Clearance/Side Marker	Wesbar	Bulk	100
54504-001	Protective Tail Light Bracket	Wesbar	Bulk	36

NOTE: Tail Lights, Clearance/Side Marker Lights and ID Light Bars approved for trailer accessory and towing application use. Contact your Horizon Global Representative for details.



2423273



2423274



2423275

PEDESTAL MOUNT TAIL LIGHTS

- Requires a 1/2 in. hole for stud mounting
- All mounting hardware included
- For easy installation the lights feature pre-wired supply wires and are self-grounding
- Red or amber snap-on acrylic lens and black acrylic cover
- Meets FMVSS/CMVSS 108 requirements and meets ASABE 4 Candle Power to the side amber light requirements
- 4.28 in. diameter x 2.16 in.

Part Number	Description	Brand	Packaging	Master Carton
2423273	Double Face, Amber Marker/Turn, Amber Marker/Turn	Wesbar	Bulk	10
2423274	Double Face, Red Stop/Tail/Turn, Amber Marker/Turn	Wesbar	Bulk	10
2423275	Single Face, Red Stop/Tail/Turn, Black	Wesbar	Bulk	10
Replacement Parts				
30-90-156	Bulb #1156, Single Filament	Wesbar	Bulk	1,000
30-90-157	Bulb #1157, Double Filament	Wesbar	-	-



2423283



2423284



2823285

COMBINATION UNDER 80 IN. TAIL LIGHTS #80 SERIES

- Universal 2 in. on center stud mounting
- Screw-on main and side marker lens allow for easy bulb replacement
- Designed for a variety of under 80 in. light-duty trailers
- Wiring uses the quick connect and disconnect feature
- Meets FMVSS/CMVSS 108 requirements
- 4-3/4 in. x 4-1/2 in. x 2-9/16 in.
- Complete kit with two tail lights, two amber clearance/side marker lights with reflex lens, 20 ft. or 25 ft. trailer wiring harness cable with molded 4-Way flat prong plug, 4 ft. car wiring harness cable with molded 4-Way flat prong plug plus license plate bracket

Part Number	Description	Brand	Packaging	Master Carton
2423283	7-Function, Left/Roadside	Wesbar	Bulk	10
2823283	7-Function, Left/Roadside	Wesbar	Clamshell	6
2423284	6-Function, Right/Curbside	Wesbar	Bulk	10
2823284	6-Function, Right/Curbside	Wesbar	Clamshell	6
31-2823285	Trailer Light Kit with 25' Wire Harness, with Rectangular Clearance/Side Marker Lights	Bargman	Clamshell	6
2823285	Trailer Light Kit with 25' Wire Harness, with Rectangular Clearance/Side Marker Lights	Wesbar	Bulk	60
407500	Trailer Light Kit with 20' Wire Harness, without Clearance/Side Marker Lights	Wesbar	Clamshell	4
Replacement Parts				
108891	Bulb #193	Wesbar	Bulk	5,000
30-90-157	Bulb #1157, Double Filament	Wesbar	-	-
2423286	Lens, Tail Light	Wesbar	Bulk	100
2423297	Lens, Red, Clearance/Side Marker	Wesbar	Bulk	100
003201	License Plate Bracket	Wesbar	Bulk	200
003211	License Plate Bracket	Wesbar	Bulk	500
54504-001	Protective Tail Light Bracket	Wesbar	Bulk	36
002301	4' Wiring Harness with 4-Way Flat Car End	Wesbar	Bulk	300
707275	4' Wiring Harness with 4-Way Flat Car End	Wesbar	Clamshell	6
002220	20' Wiring Harness with 4-Way Flat Trailer End	Wesbar	Bulk	50

NOTE: Tail Lights, Clearance/Side Marker Lights and ID Light Bars approved for trailer accessory and towing application use. Contact your Horizon Global Representative for details.

MAGNETIC TOW LIGHT KIT

- Easy attachment magnetic mounting base
- Use with RVs, cars, boats, tow trucks and trailers
- Features standard 4-Flat plug in connector
- Long 20 ft. cord reach
- Red Lenses
- Rugged durable construction
- Snap on lens
- Has replaceable 1157 bulbs



73864

Part Number	Description	Brand	Packaging	Master Carton
73864	Magnetic Tow Light Kit	Wesbar	Clamshell	2

WATERPROOF/SEALED RECESSED TAIL LIGHTS #01 SERIES

- Hermetically sealed lens prevents corrosion contributed by salt and rain
- Structurally immune to extreme heat and cold
- Lenses meet FMVSS/CMVSS 108 requirements
- Rubber grommet and three wire pigtail can be purchased separately or as a kit
- 4-1/4 in. diameter x 2-1/16 in. depth
- Cutout:
 - 1) 4-9/16 in. +/- 1/32 in. with grommet when using steel 16 gauge or thicker steel
 - 2) 4-1/2 in. +/- 1/32 in. with grommet when using fiberglass or 18 gauge or thinner steel



44-01-031



40-01-003

Part Number	Description	Brand	Packaging	Master Carton
44-01-031	Red Stop/Tail/Turn Light with Grommet with Standard Pigtail	Bargman	Display Bag	25
Replacement Parts				
40-01-001	Red Stop/Tail/Turn Light	Bargman	Bulk	100
40-01-003	Clear Backup Light	Bargman	Bulk	100
40-00-003	3 Wire Pigtail with 12" Wire Lead	Bargman	Bulk	200
40-00-004	3 Wire 90° Pigtail with 12" Wire Lead	Bargman	Bulk	200
719063	3 Wire 90° Pigtail with 12" Wire Lead	Bargman	Bulk	200
40-01-020	4" Round Grommet	Bargman	Bulk	100

NOTE: Tail Lights, Clearance/Side Marker Lights and ID Light Bars approved for trailer accessory and towing application use. Contact your Horizon Global Representative for details.

SUBMERSIBLE OVER 80 IN. TAIL LIGHTS

- Ideal for boat and PWC trailers over 80 in. wide
- Fully gasketed, screw on main and side marker lenses allow for easy bulb replacement
- Universal 2 in. on-center stud mount
- Meets FMVSS/CMVSS 108 requirements for trailers over 80 in. wide when properly mounted
- Pre-wired for easy installation
- 6.29 in. x 4.66 in. x 3.76 in. overall height



2423058



2423008

Part Number	Description	Brand	Packaging	Master Carton
2423058	7-Function, Right/Curbside	Wesbar	Bulk	50
2523074	7-Function, Right/Curbside	Wesbar	Litho Box	2
2423008	8-Function, Left/Roadside	Wesbar	Bulk	50
2523024	8-Function, Left/Roadside	Wesbar	Litho Box	2
2423500	Trailer Light Kit with 25' Wire Harness	Wesbar	Litho Box	2
Replacement Parts				
108891	Bulb #193	Wesbar	Bulk	5,000
30-90-157	Bulb #2057, Double Filament	Wesbar	-	-
2423286	Lens Red, Tail Light	Wesbar	Bulk	100
54001	Lens Red, Tail Light with Screws	Wesbar	-	-
2423287	Lens Red, Clearance/Side Marker	Wesbar	Bulk	100
54003	Lens Red, Clearance/Side Marker with Screws	Wesbar	-	-



WATERPROOF OVER 80 IN. 3X8 LOW PROFILE TAIL LIGHTS

- Reliable waterproof design
- Bulb replaceable capsule protects the bulbs from corrosion and thermal shock, but still allows for easy access for bulb replacement
- Meets FMVSS/CMVSS 108 requirements for trailers over 80 in. wide when properly mounted
- 8.03 in. x 2.94 in. x 2.83 in.
- The kit comes complete with two tail lights, two sealed amber surface mount clearance/side marker lights with reflex lens, 25 ft. trailer wiring harness cable with molded four prong plug, 4 ft. four wire car wiring harness cable with molded 4-Flat plug plus license plate bracket



Part Number	Description	Brand	Packaging	Master Carton
006554	7-Function, Right/Curbside, Two Supply Wires and Ring Terminal Ground	Wesbar	Bulk	12
403076	7-Function, Right/Curbside, Two Supply Wires and Ring Terminal Ground	Wesbar	Bulk	12
006504	8-Function, Left/Roadside, Two Supply Wires and Ring Terminal Ground	Wesbar	Bulk	12
403026	8-Function, Left/Roadside, Two Supply Wires and Ring Terminal Ground	Wesbar	Bulk	12
106411	7-Function, Right/Curbside, Trailer Ground Connection with Molded 2-Way Plug and Ring Terminal Ground	Wesbar	Bulk	12
106410	8-Function, Left/Roadside, Trailer Ground Connection with Molded 2-Way Plug and Ring Terminal Ground	Wesbar	Bulk	12
007539	Trailer Light Kit with 25' Wire Harness	Wesbar	Bulk	12
007509	Trailer Light Kit with 25' Wire Harness	Wesbar	Bulk	12
Replacement Parts				
108891	Bulb #193	Wesbar	Bulk	5,000
30-84-057	Bulb #2057, Double Filament	Wesbar	Bulk	1,000
90-03-336	Lens Set Red, (2) Tail Light and (2) Clearance/Side Marker with Screws	Wesbar	Display Bag	12
403336	Lens Set Red, (2) Tail Light and (2) Clearance/Side Marker with Screws	Wesbar	Clamshell	12
003101	Clearance Light Amber with Black Stud Mount Base	Wesbar	Bulk	100
203111	Clearance Light Amber with Black Stud Mount Base	Wesbar	Clamshell	12
003201	License Plate Bracket	Wesbar	Bulk	200
003211	License Plate Bracket	Wesbar	Bulk	500
002301	4' Wiring Harness with 4-Way Flat Car End	Wesbar	Bulk	300
707275	4' Wiring Harness with 4-Way Flat Car End	Wesbar	Clamshell	6
108825	25' Wiring Harness with 4-Way Flat Trailer End	Wesbar	Bulk	5
707261	25' Wiring Harness with 4-Way Flat Trailer End	Wesbar	Clamshell	6

NOTE: Tail Lights, Clearance/Side Marker Lights and ID Light Bars approved for trailer accessory and towing application use. Contact your Horizon Global Representative for details.



WATERPROOF/SEALED RECESSED TAIL LIGHTS #06 SERIES



413560



401591



2423056



2423006



2527511

- Oval design allows for installation in narrower channels
- Hermetically sealed lens prevents corrosion from salt and rain
- Structurally immune to extreme heat and cold
- Lenses meet FMVSS/CMVSS 108 requirements
- 6-1/2 in. x 2-1/4 in. x 2-3/8 in. depth
- Cutout: 6-3/4 in. x 2-1/2 in.

Part Number	Description	Brand	Packaging	Master Carton
413560	Red Stop/Tail/Turn Light with Grommet and Standard Pigtail	Wesbar	Poly Bag	12
403080	Red Stop/Tail/Turn Light with Grommet and Standard Pigtail	Wesbar	Bulk	100
44-06-031	Red Stop/Tail/Turn Light with Grommet and Standard Pigtail	Bargman	Display Bag	25
Replacement Parts				
40-06-001	Red Stop/Tail/Turn Light	Bargman	-	-
44-06-001	Red Stop/Tail/Turn Light	Bargman	Display Bag	25
403085	Red Stop/Tail/Turn Light	Wesbar	Clamshell	6
40-00-003	3 Wire Pigtail with 12" Wire Lead	Bargman	Bulk	200
40-00-004	3 Wire 90° Pigtail with 12" Wire Lead	Bargman	Bulk	200
719063	3 Wire 90° Pigtail with 12" Wire Lead	Wesbar	Bulk	200
40-06-020	6" Oval Grommet	Bargman	Bulk	100
416088	6" Oval Grommet	Wesbar	Poly Bag	12
108119	6" Oval Mounting Bracket	Wesbar	Boxed	20
106873	6" Oval Mounting Bracket	Wesbar	Poly Bag	12
401591	6" Oval Grommet and 3 Wire 90° Pigtail	Wesbar	Bulk	100

SUBMERSIBLE UNDER 80 IN. TAIL LIGHTS



- Ideal for boat and PWC trailers less than 80 in. wide
- Fully gasketed, screw on lens allow for easy bulb replacement
- Universal 2 in. on-center stud mount
- 5.25 in. x 4.66 in. x 3.76 in. overall height
- The kit comes with two tail lights, two sealed amber surface mount clearance/side marker lights with reflex lens, 25 ft. trailer wiring harness cable with molded four prong plug, 4 ft. four wire car wiring harness cable with molded 4-Way plug plus license plate bracket

Part Number	Description	Brand	Packaging	Master Carton
2423056	6-Function, Right/Curbside	Wesbar	Bulk	50
2523073	6-Function, Right/Curbside	Wesbar	Litho Box	2
2423006	7-Function, Left/Roadside	Wesbar	Bulk	50
2523023	7-Function, Left/Roadside	Wesbar	Litho Box	2
2527511	Trailer Light Kit with 25' Wire Harness	Wesbar	Litho Box	2
Replacement Parts				
108891	Bulb #193	Wesbar	Bulk	5,000
30-90-157	Bulb #1157, Double Filament	Wesbar	-	-
2423286	Lens, Tail Light	Wesbar	Bulk	100
2423287	Lens, Red, Clearance/Side Marker	Wesbar	Bulk	100
54001	Lens Red, Tail Light with Screws	Wesbar	Poly Bag	24
54002	Lens Red, Clearance/Side Marker with Screws	Wesbar	Poly Bag	24



SUBMERSIBLE OVER 80 IN. 4X6 LOW PROFILE TAIL LIGHTS

- Unique, compact size and shape allows these lights to fit where space is limited
- The lens is sonically-sealed to the base providing a “bell jar,” making this lamp fully submersible with easily replaceable bulbs
- Meets FMVSS/CMVSS 108 requirements for trailers over 80 in. wide when properly mounted
- Pre-wired with 2-Way molded plugs and ring terminal ground for easy installation
- 6 in. x 3-1/2 in. x 2-1/4 in.
- The kit comes complete with two tail lights, two amber clearance/side marker lights with reflex lens, 20 ft. trailer wiring harness cable with molded four prong plug, 4 ft. four wire car wiring harness cable with molded 4-flat plug plus license plate bracket

423075



423025



417515



Part Number	Description	Brand	Packaging	Master Carton
423075	6-Function, Right/Curbside	Wesbar	Bulk	25
403075	6-Function, Right/Curbside	Wesbar	Bulk	25
423025	7-Function, Left/Roadside	Wesbar	Bulk	25
403025	7-Function, Left/Roadside	Wesbar	Bulk	25
417515	Trailer Light Kit with 20' Wire Harness	Wesbar	Bulk	25
407515	Trailer Light Kit with 20' Wire Harness	Wesbar	Clamshell	4
Replacement Parts				
108891	Bulb #193	Wesbar	Bulk	5,000
30-90-157	Bulb #2057, Double Filament	Wesbar	-	-
223117	Clearance/Side Marker, Amber, Stud Mount with Reflex	Wesbar	Bulk	100
203117	Clearance/Side Marker, Amber, Stud Mount with Reflex	Wesbar	Clamshell	12
003328	Lens Amber, Clearance/Side Marker	Wesbar	Bulk	875
90-03-328	Lens Amber, Clearance/Side Marker with Screw	Bargman	Display Bag	12
003338	Lens Amber, Clearance/Side Marker with Screw	Wesbar	Poly Bag	24
003201	License Plate Bracket	Wesbar	Bulk	200
003211	License Plate Bracket	Wesbar	Bulk	500
002301	4' Wiring Harness with 4-Flat Car End	Wesbar	Bulk	200
707275	4' Wiring Harness with 4-Flat Car End	Wesbar	Clamshell	6
002220	20' Wiring Harness with 4-Flat Car End	Wesbar	Bulk	500

NOTE: Tail Lights, Clearance/Side Marker Lights and ID Light Bars approved for trailer accessory and towing application use. Contact your Horizon Global Representative for details.

WATERPROOF COURTESY LIGHTS



- Sealed lights with #193 bulbs
- Ideal for a variety of interior and exterior applications
- Lens and base are constructed of extra-tough polycarbonate to resist damage
- 2.15 in. x 1.125 in. x 1.035 in. with 0.70 in. depth

003232



Part Number	Description	Brand	Packaging	Master Carton
003232	Courtesy Light with Self-Grounding Stud Mount, Single Wire with Molded Barrel	Wesbar	Bulk	100

54005



273560



401591



WATERPROOF LED 6 IN. OVAL GROMMET MOUNT COURTESY LIGHT

- Waterproof 10 diode courtesy/utility light
- Horizontal and vertical mount applications
- LED provides longer life, brighter more focused illumination and less current draw than incandescent lamps
- Grommet and 3 prong wiring pigtail available separately
- 6.42 in. x 2.25 in. x 1.00 with 0.77 in. depth



Part Number	Description	Brand	Packaging	Master Carton
54005	LED Oval Courtesy Light Clear with Grommet with 3 Wire 90° Pigtail	Wesbar	Bulk	20
273560	LED Oval Courtesy Light Clear	Wesbar	Bulk	20
Replacement Parts				
40-00-003	3 Wire Pigtail with 12" Wire Lead	Bargman	Bulk	200
40-00-004	3 Wire 90° Pigtail with 12" Wire Lead	Bargman	Bulk	200
719063	3 Wire 90° Pigtail with 12" Wire Lead	Wesbar	Bulk	200
40-06-020	6" Oval Grommet	Bargman	Bulk	100
416088	6" Oval Grommet	Wesbar	Poly Bag	12
108119	6" Oval Mounting Bracket	Wesbar	Boxed	20
106873	6" Oval Mounting Bracket	Wesbar	Poly Bag	12
401591	6" Oval Grommet and 3 Wire 90° Pigtail	Wesbar	Bulk	100

NOTE: Tail Lights, Clearance/Side Marker Lights and ID Light Bars approved for trailer accessory and towing application use. Contact your Horizon Global Representative for details.

WATERPROOF LED CLEARANCE/SIDE MARKER LIGHTS WITH REFLEX LENS

- Waterproof "tongue" lights
- Excellent for boat trailer tongue lighting
- Snap-on lens with black or white bases
- Two wire construction with either notched wires or molded single bullet and barrel
- Tested to FMVSS/CMVSS 108 requirements, P2 rated
- 2.62 in. x 1.83 in. x 0.83 in.



47-222012

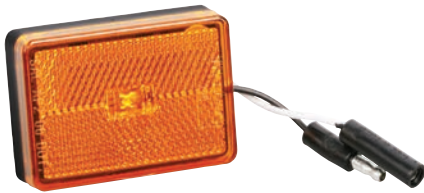

47-222014



47-222015



Part Number	Description	Brand	Packaging	Master Carton
47-222012	Clearance Light LED Amber with Reflex with Black Base, Bullet Supply, Barrel Ground	Wesbar	Bulk	100
47-222014	Clearance Light 1 Diode LED Red with Reflex with White Base, Notched Supply and Ground Wires	Wesbar	Bulk	100
47-222015	Clearance Light 1 Diode LED Amber with Reflex with White Base, Notched Supply and Ground Wires	Wesbar	Bulk	100
47-222017	Clearance Light LED Amber with Reflex with Black Base, Notched Supply and Ground Wires	Wesbar	Litho Box	4
Replacement Parts				
222012	Lens, Amber (Will Increase the Dimension of Existing Unit by 1/4")	Wesbar	Bulk	100

WATERPROOF LED CLEARANCE/SIDE MARKER LIGHTS



47-203667



47-203668

- One piece, waterproof
- Designed for grommet mounting
- Two wire pigtail features 6 in. or 18 in. wire leads with supply wire and ring terminal ground
- Pigtail and grommet available separately
- P2 rated
- 2.61 in. x 1.22 in. x 0.79 in.

Part Number	Description	Brand	Packaging	Master Carton
47-203667	Clearance Light Module LED Amber	Wesbar	Bulk	100
47-203668	Clearance Light Module LED Red	Wesbar	Bulk	100
Replacement Parts				
221588	Grommet, Rectangular	Wesbar	Bulk	200
40-00-002	2 Wire Pigtail with 6" Wire Lead	Bargman	Bulk	400
44-00-002	2 Wire Pigtail with 6" Wire Lead	Bargman	Display Bag	25
108663	2 Wire Pigtail with 18" Wire Lead	Wesbar	Bulk	100
34-108663	2 Wire Pigtail with 18" Wire Lead	Bargman	Display Bag	25

NOTE: Tail Lights, Clearance/Side Marker Lights and ID Light Bars approved for trailer accessory and towing application use. Contact your Horizon Global Representative for details.

WATERPROOF LED CLEARANCE/SIDE MARKER LIGHTS



47-106851



47-107043

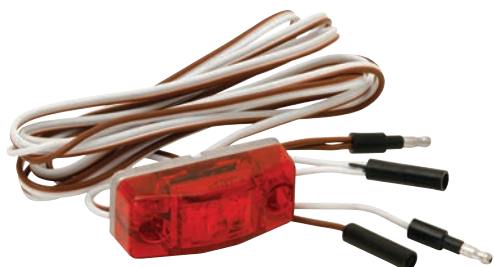

47-107046

- One piece design with thru-lens mounting holes
- Single stud on base, 1/4 in. hole required, provides self-ground
- Features wire harness with either one or two wire configurations that includes notched wires or molded single bullets and/or barrels
- P2/P3 rated
- 2.64 in. x 1.14 in. x 0.97 in. with 0.43 in. depth
- Mounting: (2) 0.25 diameter hole - 1.90 in. centers

Part Number	Description	Brand	Packaging	Master Carton
47-106851	Clearance Light LED Amber with Self-Ground Stud, 12" Brown Wire	Wesbar	Bulk	50
42-99-402	Clearance Light LED Amber with Self-Ground Stud, 12" Brown Wire	Bargman	Clamshell	12
47-99-402	Clearance Light LED Amber with Self-Ground Stud, 12" Brown Wire	Bargman	Display Bag	25
47-107043	Clearance Light LED Red with Self-Ground Stud, 12" Brown Wire	Wesbar	Bulk	50
42-99-401	Clearance Light LED Red with Self-Ground Stud, 12" Brown Wire	Bargman	Clamshell	12
47-99-401	Clearance Light LED Red with Self-Ground Stud, 12" Brown Wire	Bargman	Display Bag	25
47-106852	Clearance Light LED Amber with Self-Ground Stud, 162" Brown Bullet Pigtail	Wesbar	Bulk	50
47-106857	Clearance Light LED Amber with Self-Ground Stud, 162" Brown Bullet/White Barrel Pigtail	Wesbar	Bulk	50
47-107044	Clearance Light LED Red with Self-Ground Stud, 96" Brown Bullet/Brown Barrel Pigtail	Wesbar	Bulk	50
47-107046	Clearance Light LED Red with Self-Ground Stud, 96" Brown Bullet and Barrel/White Bullet and Barrel Pigtail	Wesbar	Bulk	50



54201-006



54201-007

WATERPROOF LED HI INTENSITY MICRO CLEARANCE/SIDE MARKER LIGHTS



- Red and amber lights are FMVSS-108 PC rated
- The clear style is ideal for auxiliary and decorative lighting
- Self contained grommet and pre-wired with sealed 12 in. wire pigtail
- 0.75 in. light diameter x 0.50 in. height, 1 in. diameter with grommet
- Recommended hole size is 0.75 in. and the recommended material thickness is between 0.0625 in. and 0.125 in.

Part Number	Description	Brand	Packaging	Master Carton
54201-006	Hi Intensity Micro Clearance Light LED Amber	Bargman	Bulk	600
54201-007	Hi Intensity Micro Clearance Light LED Red	Bargman	Bulk	600
54201-008	Hi Intensity Micro Clearance Light LED Clear	Bargman	Bulk	600

NOTE: Tail Lights, Clearance/Side Marker Lights and ID Light Bars approved for trailer accessory and towing application use. Contact your Horizon Global Representative for details.



54201-014

LED FENDER CLEARANCE LIGHTS

- Compact and waterproof
- Durable polycarbonate construction with rubber gasket
- European marketplace approved, P2 Rated
- 11.8 in. wire leads
- Dimensions: 1-1/2 in. tall x 5-1/4 in. long

Part Number	Description	Brand	Packaging	Master Carton
54201-011	LED Fender Clearance Light Left Side	Bargman	Bulk	50
54201-013	LED Fender Clearance Light Right Side	Bargman	Bulk	50
54201-014	LED Fender Clearance Light Kit	Bargman	Bulk	50



47-106853



47-106854



47-107047

WATERPROOF LED CLEARANCE/SIDE MARKER LIGHTS



- FMVSS/CMVSS 108 compliant
- Waterproof with 2 diodes
- One piece design with thru-lens mounting holes
- 18 in. two wire construction
- P2/P3 rated
- 2.60 in. x 1.10 in. x 0.75 in. height
- Mounting: (2) 0.25 in. diameter hole - 1.90 in. centers

Part Number	Description	Brand	Packaging	Master Carton
47-106853	Clearance Light LED Amber	Wesbar	Bulk	50
54201-001	Clearance Light LED Amber with Chrome Bezel	Wesbar	Clamshell	6
47-106854	Clearance Light LED Clear Lens with Amber Diodes	Wesbar	Bulk	50
47-107047	Clearance Light LED Red	Wesbar	Bulk	50
54201-002	Clearance Light LED Red with Chrome Bezel	Wesbar	Clamshell	6
47-107048	Clearance Light LED Clear Lens with Red Diodes	Wesbar	Bulk	50
Replacement Parts				
47-106020	Chrome Bezel, 3.23" x 1.73" x 0.47" height	Wesbar	Bulk	100

WATERPROOF LED CLEARANCE/SIDE MARKER LIGHTS #37 SERIES



- Easy installation, snap lock base mount
- Tested and certified to FMVSS/CMVSS 108 clearance/side marker light requirements, P2 rated
- Module Only: 2.60 in. x 1.20 in. x 1.03 in. overall height
- Module with Base: 2-7/8 in. x 1-1/2 in. x 1 in.

401581



401580



401566



401565



Part Number	Description	Brand	Packaging	Master Carton
47-37-031	Clearance Light LED #37 Red with Black Base	Bargman	Display Bag	25
401581	Clearance Light LED #37 Red with Black Base	Wesbar	Bulk	100
47-37-032	Clearance Light LED #37 Amber with Black Base	Bargman	Display Bag	25
401580	Clearance Light LED #37 Amber with Black Base	Wesbar	Bulk	100
47-37-005	Clearance Light Module LED #37 Red, PC Rated When Properly Mounted	Bargman	Bulk	400
47-37-006	Clearance Light Module LED #37 Amber, PC Rated When Properly Mounted	Bargman	Bulk	400
Replacement Parts				
47-37-001	Clearance Light Module LED #37 Red	Bargman	Bulk	400
42-37-401	Clearance Light Module LED #37 Red	Bargman	Clamshell	12
47-37-401	Clearance Light Module LED #37 Red	Bargman	Bulk	100
47-37-002	Clearance Light Module LED #37 Amber	Bargman	Bulk	400
42-37-402	Clearance Light Module LED #37 Amber	Bargman	Clamshell	12
47-37-402	Clearance Light Module LED #37 Amber	Bargman	Bulk	100
40-37-020	Black 2" Snap-Lock Base, Self-Grounding with Single Black Wire	Bargman	Bulk	400
106289	Black 2" Snap-Lock Base, Self-Grounding	Wesbar	Bulk	400
108297	Black 2" Snap-Lock Base, Open Back	Wesbar	Bulk	200
106293	Chrome 2" Snap-Lock Base, Self-Grounding	Wesbar	Bulk	400
221588	Grommet Rectangular	Wesbar	Bulk	200
40-00-002	2 Wire Pigtail with 6" Wire Lead	Bargman	Bulk	400
44-00-002	2 Wire Pigtail with 6" Wire Lead	Bargman	Display Bag	25
108663	2 Wire Pigtail with 18" Wire Lead	Wesbar	Bulk	100
34-108663	2 Wire Pigtail with 18" Wire Lead	Bargman	Bulk	100

WATERPROOF LED CLEARANCE/SIDE MARKER LIGHTS #99 SERIES



- Single wire, 12 in. minimum
- Self-grounding stud mounting with 1/4 in. required hole
- Includes type 302 stainless steel hardware
- Meets FMVSS/CMVSS 108 requirements
- PC rated when properly mounted
- 2.16 in. x 1.16 in. x 1.03 in. with 0.72 in. depth

Part Number	Description	Brand	Packaging	Master Carton
47-99-005	Clearance Light LED #99 Red	Bargman	Bulk	100
401566	Clearance Light LED #99 Red	Wesbar	Clamshell	12
47-99-006	Clearance Light LED #99 Amber	Bargman	Bulk	100
401565	Clearance Light LED #99 Amber	Wesbar	Clamshell	12

LED CLEARANCE/SIDE MARKER LIGHTS #38 SERIES

- Snap lock base mount
- Easy installation
- Fully tested and certified to FMVSS/CMVSS 108 side marker/clearance light requirements
- P2 rated
- Module Only: 3.93 in. x 1.22 in. x 1.02 in. overall height
- Fender mount module only: 3.95 in. x 1.24 in. x 1.038 in. overall height



42-38-033

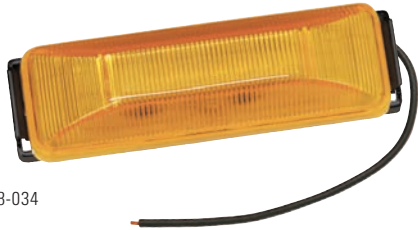

42-38-034



47-38-004



47-58-031



47-58-032

Part Number	Description	Brand	Packaging	Master Carton
42-38-033	Clearance Light LED #38 Red with Black Base with Pigtail	Bargman	Clamshell	12
47-38-033	Clearance Light LED #38 Red with Black Base with Pigtail	Bargman	Display Bag	25
401583	Clearance Light LED #38 Red with Black Base with Pigtail	Wesbar	Clamshell	12
42-38-034	Clearance Light LED #38 Amber with Black Base with Pigtail	Bargman	Clamshell	12
47-38-034	Clearance Light LED #38 Amber with Black Base with Pigtail	Bargman	Display Bag	25
401582	Clearance Light LED #38 Amber with Black Base with Pigtail	Wesbar	Clamshell	12
47-38-004	Clearance Light LED #38 Red/Amber	Bargman	Bulk	50
Replacement Parts				
47-38-001	Clearance Light Module LED #38 Red	Bargman	Bulk	500
47-38-401	Clearance Light Module LED #38 Red	Bargman	Display Bag	25
47-38-002	Clearance Light Module LED #38 Amber	Bargman	Bulk	500
47-38-402	Clearance Light Module LED #38 Amber	Bargman	Display Bag	25
40-38-020	Black Base with Wire Assembly, Self-Grounding with Single Black Wire	Bargman	Bulk	100
40-38-025	Black Base with 2 Wires	Bargman	Bulk	100

NOTE: Tail Lights, Clearance/Side Marker Lights and ID Light Bars approved for trailer accessory and towing application use. Contact your Horizon Global Representative for details.

LED CLEARANCE/SIDE MARKER LIGHT KITS #58 SERIES

- Snap lock base mount
- 4 in. x 2 in. x 1 in.

Part Number	Description	Brand	Packaging	Master Carton
47-58-031	Clearance Light LED #58 Red with Pigtail, with White Base	Bargman	Display Bag	25
47-58-032	Clearance Light LED #58 Amber with Pigtail, with White Base	Bargman	Display Bag	25
47-58-001	Clearance Light LED #58 Red with White Base	Bargman	Bulk	200
401586	Clearance Light LED #58 Red with White Base	Wesbar	Clamshell	12
47-58-002	Clearance Light LED #58 Amber with White Base	Bargman	Bulk	200
401585	Clearance Light LED #58 Amber with White Base	Wesbar	Clamshell	12
Replacement Parts				
40-00-005	Pigtail	Bargman	Bulk	800

LED CLEARANCE/SIDE MARKER LIGHTS 2-1/2 IN. ROUND

- Surface mount design
- 2-Wire construction simplifies grounding
- These lights meet FMVSS-108 and CMVSS-108 requirements for P2 and PC side marker clearance functions when properly mounted

54201-015



54201-017



Part Number	Description	Brand	Packaging	Master Carton
54201-015	LED Red Clearance Light with Mounting Flange	Bargman	Bulk	50
54201-016	LED Red Clearance Light with Mounting Flange	Bargman	Bulk	144
54201-017	LED Amber Clearance Light with Mounting Flange	Bargman	Bulk	50
54201-018	LED Amber Clearance Light with Mounting Flange	Bargman	Bulk	144

LED CLEARANCE/SIDE MARKER LIGHTS #59 SERIES WITH REFLEX LENS

- Rugged ABS base with LED light engine assembled directly into reflectorized acrylic lens
- LED light engine consists of 2 LED lights that are mounted into a circuit board that is then potted and sealed to protect against water and other elements
- 4 in. x 2 in. x 1-1/32 in. with 5/8 in. depth

42-59-401



42-59-402



Part Number	Description	Brand	Packaging	Master Carton
47-59-001	Clearance Light LED #59 Red with White Base with Pigtail	Bargman	Bulk	100
42-59-401	Clearance Light LED #59 Red with White Base with Pigtail	Bargman	Clamshell	12
47-59-401	Clearance Light LED #59 Red with White Base with Pigtail	Bargman	Display Bag	25
47-59-002	Clearance Light LED #59 Amber with White Base with Pigtail	Bargman	Bulk	100
42-59-402	Clearance Light LED #59 Amber with White Base with Pigtail	Bargman	Clamshell	12
47-59-402	Clearance Light LED #59 Amber with White Base with Pigtail	Bargman	Display Bag	25

LED MODULE UPGRADE KITS #59 SERIES

- Designed to convert Bargman #59 Incandescent Clearance/Side Marker Lights to LED WITHOUT having to remove the base
- Simply remove the lens and the incandescent bulb and plug in the LED light engine (lens and LED lights)

42-59-410



42-59-412



Part Number	Description	Brand	Packaging	Master Carton
47-59-010	Upgrade Kit, Lens Module LED #59 Red	Bargman	Bulk	100
42-59-410	Upgrade Kit, Lens Module LED #59 Red	Bargman	Clamshell	25
47-59-410	Upgrade Kit, Lens Module LED #59 Red	Bargman	Display Bag	25
47-59-012	Upgrade Kit, Lens Module LED #59 Amber	Bargman	Bulk	100
42-59-412	Upgrade Kit, Lens Module LED #59 Amber	Bargman	Clamshell	25
47-59-412	Upgrade Kit, Lens Module LED #59 Amber	Bargman	Display Bag	25



47-86-202

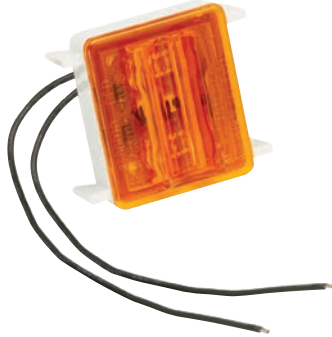

42-86-412



42-86-410



44-30-031



401589

LED WRAP-AROUND CLEARANCE/SIDE MARKER LIGHTS #86 SERIES

- Meets lighting requirements for side markers and clearance lights and doubles as a Class "A" side-reflex reflector
- Meets FMVSS/CMVSS 108 requirements
- 5-3/4 in. x 4-3/8 in. x 2-3/16 in.

Part Number	Description	Brand	Packaging	Master Carton
47-86-202	LED Stop/Tail/Turn Light Lens Module Red with Bulb Socket Plug	Bargman	Bulk	20
48-86-202	LED Stop/Tail/Turn Light Lens Module Red with Bulb Socket Plug	Bargman	Display Bag	5
Replacement Parts				
42-86-410	LED Wrap-Around Clearance Light Module Red	Bargman	Clamshell	12
42-86-412	LED Wrap-Around Clearance Light Module Amber	Bargman	Clamshell	12
30-86-711	Lens #86 Red Wrap-Around	Bargman	Bulk	20
34-86-711	Lens #86 Red Wrap-Around	Bargman	Display Bag	25
30-86-712	Lens #86 Amber Wrap-Around	Bargman	Bulk	20
34-86-712	Lens #86 Amber Wrap-Around	Bargman	Display Bag	25
30-84-075	Marker Light Lens Screw	Bargman	-	-

WATERPROOF/SEALED CLEARANCE/SIDE MARKER LIGHTS #30 SERIES



- Designed for quick and easy installation
- Rugged ABS base that has the acrylic lens sonic welded to the base
- Flush mount rubber grommet and two wire pigtail can be purchased separately or as a kit
- 2 in. diameter x 3/4 in., 2-3/4 in. diameter with grommet
- Cutout: 2-5/16 in. diameter

Part Number	Description	Brand	Packaging	Master Carton
44-30-031	Clearance Light #30 Red with Grommet with 6" Pigtail	Bargman	Bulk	200
Replacement Parts				
40-30-001	Clearance Light Module #30 Red	Bargman	Bulk	400
41-30-001	Clearance Light Module #30 Red	Bargman	Clamshell	12
44-30-001	Clearance Light Module #30 Red	Bargman	Display bag	25
203381	Clearance Light Module #30 Red	Wesbar	Clamshell	12
40-30-002	Clearance Light Module #30 Amber	Bargman	Bulk	400
41-30-002	Clearance Light Module #30 Amber	Bargman	Clamshell	12
44-30-002	Clearance Light Module #30 Amber	Bargman	Display Bag	25
203380	Clearance Light Module #30 Amber	Wesbar	Clamshell	12
40-00-002	2 Wire Pigtail with 6" Wire Lead	Bargman	Bulk	400
44-00-002	2 Wire Pigtail with 6" Wire Lead	Bargman	Display Bag	25
108663	2 Wire Pigtail with 18" Wire Lead	Wesbar	Bulk	100
34-108663	2 Wire Pigtail with 18" Wire Lead	Bargman	Bulk	100
40-30-020	2" Round Grommet	Bargman	Bulk	400
44-30-020	2" Round Grommet	Bargman	Display Bag	25
401589	2" Round Grommet and 2 Wire Pigtail with 6" Wire Lead	Wesbar	Display Bag	6

WATERPROOF/SEALED CLEARANCE/SIDE MARKER LIGHTS #37 SERIES



- Compact rectangular light with the polycarbonate lens sonic welded to the base
- Offers easy installation with self grounding base on metallic surfaces
- Snap lock tabs on the lens housing secures light to base to complete the fast installation
- Complies with FMVSS/CMVSS 108 requirements for combination clearance/marker light when mounted properly
- 2-1/2 in. x 1-1/4 in.



44-37-031



44-37-032



203295



203294



40-37-020

Part Number	Description	Brand	Packaging	Master Carton
41-37-031	Clearance Lens #37 Red with Black Base with Wire	Bargman	Clamshell	12
44-37-031	Clearance Lens #37 Red with Black Base with Wire	Bargman	Display Bag	25
203293	Clearance Lens #37 Red with Black Base with Wire	Wesbar	Clamshell	12
41-37-032	Clearance Lens #37 Amber with Black Base with Wire	Bargman	Clamshell	12
44-37-032	Clearance Lens #37 Amber with Black Base with Wire	Bargman	Display Bag	25
203292	Clearance Lens #37 Amber with Black Base with Wire	Wesbar	Clamshell	12
203294	Clearance Lens #37 Amber with Chrome Base with Wire	Wesbar	Clamshell	12
203295	Clearance Lens #37 Red with Chrome Base with Wire	Wesbar	Clamshell	12
Replacement Parts				
40-37-001	Clearance Light Module #37 Red	Bargman	Bulk	50
203396	Clearance Light Module #37 Red	Wesbar	Clamshell	12
40-37-002	Clearance Light Module #37 Amber	Bargman	Bulk	50
203395	Clearance Light Module #37 Amber	Wesbar	Clamshell	12
40-37-020	Black 2" Snap-Lock Base, Self-Grounding with Single Black Wire	Bargman	Bulk	400
106289	Black 2" Snap-Lock Base, Self-Grounding	Wesbar	Bulk	400
108297	Black 2" Snap-Lock Base, Open Back	Wesbar	Bulk	100
106293	Chrome 2" Snap-Lock Base, Self-Grounding	Wesbar	Bulk	400
221588	Grommet Rectangular	Wesbar	Bulk	200
106334	Single Plug for Snap-Lock Base	Wesbar	Bulk	144
40-00-002	2 Wire Pigtail with 6" Wire Lead	Bargman	Bulk	400
44-00-002	2 Wire Pigtail with 6" Wire Lead	Bargman	Display Bag	25
108663	2 Wire Pigtail with 18" Wire Lead	Wesbar	Bulk	100
34-108663	2 Wire Pigtail with 18" Wire Lead	Bargman	Bulk	100

NOTE: Tail Lights, Clearance/Side Marker Lights and ID Light Bars approved for trailer accessory and towing application use. Contact your Horizon Global Representative for details.



Wet Location Lighting Products

WATERPROOF/SEALED CLEARANCE/SIDE MARKER LIGHTS #38 SERIES



- Double bulb rectangular light with the polycarbonate lens sonic welded to the base
- Easy installation with self grounding base on metallic surfaces
- Snap-lock tabs on the lens housing secures light to base to complete the fast installation
- Complies with FMVSS/CMVSS 108 requirements for combination clearance/marker light when mounted properly
- P2 rated
- 3-13/16 in. x 1-1/4 in.



44-38-031



44-38-032



40-38-004

Part Number	Description	Brand	Packaging	Master Carton
41-38-031	Clearance Lens #38 Red with Black Base with Wire Assembly	Bargman	Clamshell	12
44-38-031	Clearance Lens #38 Red with Black Base with Wire Assembly	Bargman	Display Bag	12
41-38-032	Clearance Lens #38 Amber with Black Base with Wire Assembly	Bargman	Clamshell	12
44-38-032	Clearance Lens #38 Amber with Black Base with Wire Assembly	Bargman	Display Bag	12
40-38-004	Fender Mount Clearance Light Module #38 Red/Amber	Bargman	Bulk	50
Accessory				
40-40-120	Fender Mount Black Base for Two Lights	Bargman	-	-
Replacement Parts				
40-38-001	Clearance Light Module #38 Red	Bargman	Bulk	400
40-38-002	Clearance Light Module #38 Amber	Bargman	Bulk	400
40-38-020	Black Base with Wire Assembly, Self-Grounding with Single Black Wire	Bargman	Bulk	100
40-38-025	Black Base with 2 Wires	Bargman	Bulk	100

SONICALLY-SEALED WATERPROOF CLEARANCE/SIDE MARKER LIGHTS



- Break-resistant polycarbonate lens
- Available in either stud-mount or ear-mount styling
- Features a pre-installed 15 in. pigtail
- Meets FMVSS/CMVSS 108 requirements for clearance/marker lights when properly mounted
- Stud: 2-1/8 in. x 1-1/8 in. x 1-1/16 in.
- Ear: 3-5/16 in. x 1-5/16 in. x 1 in.



003239



003231



003230

Part Number	Description	Brand	Packaging	Master Carton
003273	Clearance Light Red, White Ear-Mount Base	Wesbar	Bulk	100
203286	Clearance Light Red, White Ear-Mount Base	Wesbar	Clamshell	12
003231	Clearance Light Red, White Stud-Mount Base	Wesbar	Bulk	100
203234	Clearance Light Red, White Stud-Mount Base	Wesbar	Clamshell	12
003239	Clearance Light Red, Black Stud-Mount Base	Wesbar	Bulk	100
003272	Clearance Light Amber, White Ear-Mount Base	Wesbar	Bulk	100
203285	Clearance Light Amber, White Ear-Mount Base	Wesbar	Clamshell	12
003230	Clearance Light Amber, White Stud-Mount Base	Wesbar	Bulk	100
203233	Clearance Light Amber, White Stud-Mount Base	Wesbar	Clamshell	12
003238	Clearance Light Amber, Black Stud-Mount Base	Wesbar	Bulk	100

WRAP-AROUND CLEARANCE/SIDE MARKER LIGHTS #86 SERIES

- Meets lighting requirements for side markers and clearance lights and doubles as a Class "A" side-reflex reflector
- Meets FMVSS/CMVSS 108 requirements
- 5-3/4 in. x 4-3/8 in. x 2-3/16 in.

30-86-202



30-86-203



Part Number	Description	Brand	Packaging	Master Carton
30-86-202	Clearance Light #86 Red with Black Base	Bargman	Bulk	20
34-86-202	Clearance Light #86 Red with Black Base	Bargman	Display Bag	5
30-86-203	Clearance Light #86 Amber with Black Base	Bargman	Bulk	20
34-86-203	Clearance Light #86 Amber with Black Base	Bargman	Display Bag	5
Replacement Parts				
30-86-711	Lens #86 Red Wrap-Around	Bargman	Bulk	20
34-86-711	Lens #86 Red Wrap-Around	Bargman	Display Bag	5
30-86-712	Lens #86 Amber Wrap-Around	Bargman	Bulk	20
34-86-712	Lens #86 Amber Wrap-Around	Bargman	Display Bag	5
30-84-075	Marker Light Lens Screw	Bargman	-	-

NOTE: Tail Lights, Clearance/Side Marker Lights and ID Light Bars approved for trailer accessory and towing application use. Contact your Horizon Global Representative for details.

CLEARANCE/SIDE MARKER LIGHTS #59 SERIES WITH REFLEX LENS

- Rugged ABS base and acrylic snap-on reflex lens
- Molded socket protects bulb from road shock and has two wires to eliminate surface ground
- Molded grommet extends through the skin to protect the wiring
- 4 in. x 2 in. x 1-1/32 in. with 5/8 in. depth

30-59-001



30-59-002



30-59-003



30-59-004



Part Number	Description	Brand	Packaging	Master Carton
30-59-001	Clearance Light #59 Red with White Base	Bargman	Bulk	100
31-59-001	Clearance Light #59 Red with White Base	Bargman	Clamshell	12
34-59-001	Clearance Light #59 Red with White Base	Bargman	Display Bag	25
30-59-003	Clearance Light #59 Red with Black Base	Bargman	Bulk	100
30-59-002	Clearance Light #59 Amber with White Base	Bargman	Bulk	100
31-59-002	Clearance Light #59 Amber with White Base	Bargman	Clamshell	12
34-59-002	Clearance Light #59 Amber with White Base	Bargman	Display Bag	25
30-59-004	Clearance Light #59 Amber with Black Base	Bargman	Bulk	100
Replacement Parts				
30-58-702	Wedge Base Socket with #194 Bulb	Bargman	Bulk	-
30-59-010	Lens #59 Red	Bargman	Bulk	100
31-59-010	Lens #59 Red	Bargman	Clamshell	12
34-59-010	Lens #59 Red	Bargman	Display Bag	25
30-59-012	Lens #59 Amber	Bargman	Bulk	100
31-59-012	Lens #59 Amber	Bargman	Clamshell	12
34-59-012	Lens #59 Amber	Bargman	Display Bag	25
30-58-024	White Base	Bargman	Bulk	100
30-59-054	Gasket, Foam	Bargman	Bulk	-

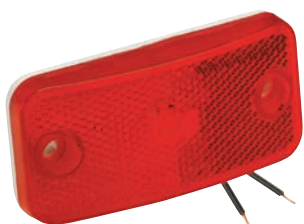

30-17-814



30-17-815

CLEARANCE/SIDE MARKER LIGHTS #178 SERIES WEATHER-TIGHT WITH REFLEX LENS

- Low profile, one-piece construction
- Radius styling
- ABS base and acrylic reflex lens
- Two wire design eliminates surface ground
- 3-7/8 in. x 1-7/8 in. x 3/4 in. with 3/4 in. depth

Part Number	Description	Brand	Packaging	Master Carton
30-17-814	Clearance Light #178 Red with White Base with 14" Wires	Bargman	Bulk	100
34-17-808	Clearance Light #178 Red with White Base with 14" Wires	Bargman	Display Bag	25
30-17-815	Clearance Light #178 Amber with White Base with 14" Wires	Bargman	Bulk	100
34-17-809	Clearance Light #178 Amber with White Base with 14" Wires	Bargman	Display Bag	25
Replacement Parts				
30-58-702	Wedge Base Socket with #194 Bulb	Bargman	-	-
30-17-034	Gasket-Foam	Bargman	Bulk	-
34-17-034	Gasket-Foam	Bargman	Display Bag	25

NOTE: Tail Lights, Clearance/Side Marker Lights and ID Light Bars approved for trailer accessory and towing application use. Contact your Horizon Global Representative for details.



30-58-001



30-58-002



30-58-007†

CLEARANCE/SIDE MARKER LIGHTS #58 SERIES

- Rugged ABS base and acrylic snap-on lens
- Molded socket protects bulb from road shock and has two wires to eliminate surface ground
- Molded grommet extends through the skin to protect the wiring
- 4 in. x 2 in. x 1-1/32 in. with 5/8 in. depth

Part Number	Description	Brand	Packaging	Master Carton
30-58-001	Clearance Light #58 Red with White Base	Bargman	Bulk	100
34-58-001	Clearance Light #58 Red with White Base	Bargman	Display Bag	25
30-58-002	Clearance Light #58 Amber with White Base	Bargman	Bulk	100
34-58-002	Clearance Light #58 Amber with White Base	Bargman	Display Bag	25
54201-010†	Clearance Light #58 Amber with Black Base	Bargman	Bulk	100
30-58-007†	Utility Light #58 Clear with White Base	Bargman	Bulk	100
Replacement Parts				
30-58-702	Wedge Base Socket with #194 Bulb	Bargman	Bulk	-
30-58-010	Lens #58 Red	Bargman	Bulk	100
34-58-010	Lens #58 Red	Bargman	Display Bag	25
30-58-012	Lens #58 Amber	Bargman	Bulk	100
34-58-012	Lens #58 Amber	Bargman	Display Bag	25
30-58-024	White Base	Bargman	Bulk	100
30-59-054	Gasket, Foam	Bargman	Bulk	-

† = Available while supplies last

CLEARANCE/SIDE MARKER LIGHTS 2-3/4 IN. ROUND

- Surface mount design
- Two wire construction simplifies grounding
- Meets FMVSS-108 and CMVSS-108 requirements for P2 and PC side marker clearance functions when properly mounted

30-073833



30-073834



Part Number	Description	Brand	Packaging	Master Carton
30-073833	Clearance Light Red Round with Two Wire Construction	Bargman	Bulk	-
30-073834	Clearance Light Amber Round with Two Wire Construction	Bargman	Bulk	-
Replacement Parts				
108891	Bulb #193	Wesbar	Bulk	5,000

DUAL BULB CLEARANCE/SIDE MARKER LIGHTS

- Specifically designed for both heavy-duty and industrial use
- Polycarbonate lens
- Pre-wired with a 6 in. supply lead and are self-grounding
- 4 in. x 2 in. x 1-1/8 in.

003441



003440



Part Number	Description	Brand	Packaging	Master Carton
003441	Clearance Light Red	Wesbar	Bulk	50
32-003441	Clearance Light Red	Bargman	Clamshell	12
003440	Clearance Light Amber	Wesbar	Bulk	50
32-003440	Clearance Light Amber	Bargman	Clamshell	12
Replacement Parts				
108891	Bulb #193	Wesbar	Bulk	5,000

CLEARANCE/SIDE MARKER LIGHTS #99 SERIES WITH REFLEX LENS

- Acrylic snap-on reflex lens
- Ready for mounting on a flat surface with quick connect wiring installation for supply and ground wires
- 4-1/16 in. x 1-3/8 in. x 1 in.

31-99-001



31-99-002



Part Number	Description	Brand	Packaging	Master Carton
30-99-001	Clearance Light #99 Red	Bargman	Bulk	100
31-99-001	Clearance Light #99 Red	Bargman	Clamshell	12
34-99-001	Clearance Light #99 Red	Bargman	Display Bag	25
30-99-002	Clearance Light #99 Amber	Bargman	Bulk	100
31-99-002	Clearance Light #99 Amber	Bargman	Clamshell	12
34-99-002	Clearance Light #99 Amber	Bargman	Display Bag	25
Accessory				
40-40-120	Two Light Fender Mount Bezel	Bargman	-	-
Replacement Parts				
30-99-010	Lens #99 Red, Clearance Light	Bargman	Bulk	200
34-99-010	Lens #99 Red, Clearance Light	Bargman	Display Bag	25
30-99-012	Lens #99 Amber, Clearance Light	Bargman	Bulk	200
34-99-012	Lens #99 Amber, Clearance Light	Bargman	Display Bag	25

CLEARANCE/SIDE MARKER LIGHTS WITH REFLEX LENS

- Stud mount
- Reflex lens and 18 in. wire lead
- Includes a tapered base for easy installation
- 2-3/4 in. x 2 in. x 1 in.

203116



223117

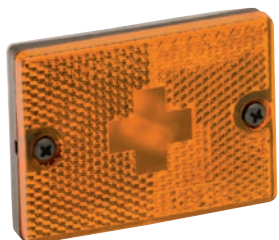

Part Number	Description	Brand	Packaging	Master Carton
203116	Clearance Light Red	Wesbar	Clamshell	12
223117	Clearance Light Amber	Wesbar	Bulk	100
203117	Clearance Light Amber	Wesbar	Clamshell	12
Replacement Parts				
108891	Bulb #193	Wesbar	Bulk	5,000
003327	Lens Red, Clearance Light	Wesbar	Bulk	875
90-03-327	Lens Red, Clearance Light with Screws	Bargman	Display Bag	12
003337	Lens Red, Clearance Light with Screws	Wesbar	Display Bag	24
003328	Lens Amber, Clearance Light	Wesbar	Bulk	875
90-03-328	Lens Amber, Clearance Light with Screws	Bargman	Display Bag	12
003338	Lens Amber, Clearance Light with Screws	Wesbar	Display Bag	24

NOTE: Tail Lights, Clearance/Side Marker Lights and ID Light Bars approved for trailer accessory and towing application use. Contact your Horizon Global Representative for details.

CLEARANCE / SIDE MARKER LIGHTS WITH REFLEX LENS

- Featuring reflex lens and quick connect wiring installation
- Available with stud-mount or ear-mount styling
- 3-1/8 in. x 2-3/8 in. x 1 in.

003103



003101

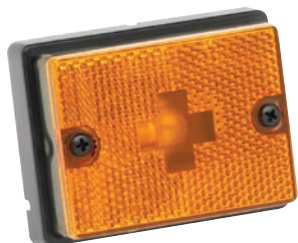

003123



003121



Part Number	Description	Brand	Packaging	Master Carton
003103	Clearance Light Red with Black Stud-Mount Base	Wesbar	Bulk	100
203113	Clearance Light Red with Black Stud-Mount Base	Wesbar	Clamshell	12
003123	Clearance Light Red with Black Ear-Mount Base	Wesbar	Bulk	100
203133	Clearance Light Red with Black Ear-Mount Base	Wesbar	Clamshell	12
003101	Clearance Light Amber with Black Stud-Mount Base	Wesbar	Bulk	100
203111	Clearance Light Amber with Black Stud-Mount Base	Wesbar	Clamshell	12
003121	Clearance Light Amber with Black Ear-Mount Base	Wesbar	Bulk	100
203131	Clearance Light Amber with Black Ear-Mount Base	Wesbar	Clamshell	12
Replacement Parts				
003327	Lens Red, Clearance Light	Wesbar	Bulk	875
90-03-327	Lens Red, Clearance Light with Screws	Bargman	Display Bag	12
003337	Lens Red, Clearance Light with Screws	Wesbar	Display Bag	24
003328	Lens Amber, Clearance Light	Wesbar	Bulk	875
90-03-328	Lens Amber, Clearance Light with Screws	Bargman	Display Bag	12
003338	Lens Amber, Clearance Light with Screws	Wesbar	Display Bag	24

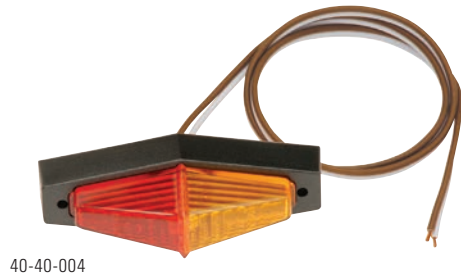

40-40-004

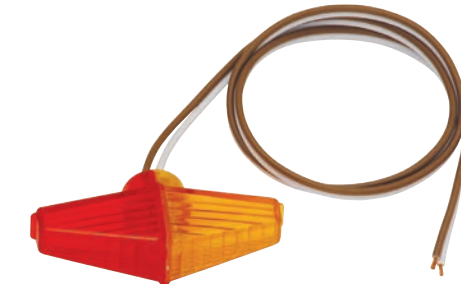

40-40-104

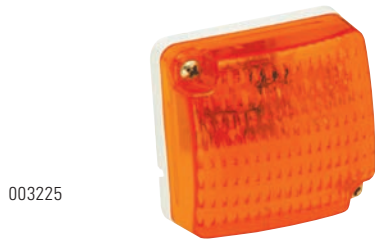

003225



003330



47-06-005



40-06-020

CLEARANCE/SIDE MARKER LIGHTS FENDER MOUNT #40 SERIES

- Dual function red/amber light for use on fender mount applications
- Bulb is protected by the lens on all sides
- Two wire design (24 in. supply and ground) eliminates surface ground
- Light with black base, stainless steel mounting screws: 3.65 in. x 1.25 in. x 1.45 in. with 0.50 in. depth
- Light only: 2.75 in. x 1 in. x 0.85 in. with 0.50 in. depth
- Fender mount bezel only: 7.20 in. x 4.85 in. x 0.85 in.

Part Number	Description	Brand	Packaging	Master Carton
40-40-004	Fender Mount Clearance Light #40 Red/Amber with Lexan® Black Base, Includes Stainless Steel Mounting Screws	Bargman	Bulk	-
44-40-004	Fender Mount Clearance Light #40 Red/Amber with Lexan® Black Base, Includes Stainless Steel Mounting Screws	Bargman	Display Bag	25
40-40-104	Fender Mount Clearance Light Red/Amber	Bargman	Bulk	100
Replacement Parts				
40-40-115	Fender Mount Bezel	Bargman	Bulk	-

CLEARANCE/SIDE MARKER LIGHT

- Featuring quick connect wiring installation with stud mounting
- Meets FMVSS/CMVSS 108 requirements for clearance/marker lights when properly mounted, PC rated
- 2-1/4 in. x 2-1/4 in. x 1-1/4 in.

Part Number	Description	Brand	Packaging	Master Carton
003225	Clearance Light Amber	Wesbar	Bulk	100
203235	Clearance Light Amber	Wesbar	Clamshell	12
Replacement Parts				
003330	Lens Amber, Clearance Light	Wesbar	Bulk	720
003340	Lens Amber, Clearance Light	Wesbar	Display Bag	24

LED 6 IN. OVAL MID-TURN LIGHT

- Certified to SAE J914 for side turn signal
- Meets FMVSS/CMVSS 108 requirements for intermediate side marker and side reflex on vehicles over 30 ft. long
- Grommet and pigtail available separately
- 6.48 in. x 2.30 in. x 2.71 in. overall height
- 2 in. depth with pigtail, 1.35 in. height

Part Number	Description	Brand	Packaging	Master Carton
47-06-005	6" Oval Mid-Turn Amber Light	Bargman	Bulk	10
Replacement Parts				
40-00-003	3 Wire Pigtail with 12" Wire Lead	Bargman	Bulk	200
40-00-004	3 Wire 90° Pigtail with 12" Wire Lead	Bargman	Bulk	200
719063	3 Wire 90° Pigtail with 12" Wire Lead	Wesbar	Display Bag	12
40-06-020	6" Oval Grommet	Bargman	Bulk	100
416088	6" Oval Grommet	Wesbar	Display Bag	12
108119	6" Oval Mounting Bracket	Wesbar	Bulk	20
106873	6" Oval Mounting Bracket	Wesbar	Display Bag	12
401591	6" Oval Grommet and 3 Wire 90° Pigtail	Wesbar	Display Bag	24

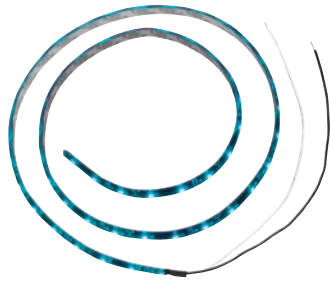

54205-011



54205-015



54205-020



54205-021



54205-024



54205-023

LED LIGHT STRIPS

- Available in 5 different colors
- Cut to length and easy termination of wires
- Offered in 36 in. strips or reel of 16 ft.
- Weather resistant
- Backed with 3m adhesive
- Operates with 12v power supply
- Pre-wired with a 12 in. supply lead and are self-grounding

Part Number	Description	Brand	Packaging	Master Carton
Strip - 36 in.				
54205-010	LED Light Strip Red, 54 Diodes Per Strip	Wesbar	Blister Card	12
54205-011	LED Light Strip Blue, 54 Diodes Per Strip	Wesbar	Blister Card	12
54205-012	LED Light Strip Amber, 54 Diodes Per Strip	Wesbar	Blister Card	12
54205-013	LED Light Strip Green, 54 Diodes Per Strip	Wesbar	Blister Card	12
54205-014	LED Light Strip Clear, 54 Diodes Per Strip	Wesbar	Blister Card	12
Reel - 16 ft.				
54205-015	LED Light Strip Red, 16' Per Reel	Wesbar	Reel	50
54205-016	LED Light Strip Blue, 16' Per Reel	Wesbar	Reel	50
54205-017	LED Light Strip Amber, 16' Per Reel	Wesbar	Reel	50
54205-018	LED Light Strip Green, 16' Per Reel	Wesbar	Reel	50
54205-019	LED Light Strip Clear, 16' Per Reel	Wesbar	Reel	50

LED MULTI-FUNCTIONAL STROBE LIGHTS

- 7 optional flashing modes
- Available in amber or clear
- Dirt and moisture resistant
- Suitable for multiple OE wiring applications

Part Number	Description	Brand	Packaging	Master Carton
54205-020	LED Multi-Functional Strobe Light - Amber	Wesbar	Boxed	20
54205-021	LED Multi-Functional Strobe Light - Clear	Wesbar	Boxed	20

LED STROBE LIGHTS WITH CORD AND MAGNETIC BASE

- Dirt and moisture resistant
- Single mode only
- Available in amber, clear or purple
- Magnetic base
- 13 ft. cord
- 12 volt power adapter included

Part Number	Description	Brand	Packaging	Master Carton
54205-022	LED Strobe Light - Amber	Wesbar	Boxed	10
54205-023	LED Strobe Light - Clear	Wesbar	Boxed	10
54205-024	LED Strobe Light - Purple	Wesbar	Boxed	10

WATERPROOF LED ID LIGHT BARS



- Three waterproof red lights
- Stainless steel base with stud mounting
- 14-1/4 in. x 1-3/16 in. x 1-1/16 in.



47-99-004

Part Number	Description	Brand	Packaging	Master Carton
47-99-004	Light Bar LED with Red Lens	Bargman	Bulk	100
47-99-034	Light Bar LED with Red Lens	Bargman	Display Bag	25
401567	Light Bar LED with Red Lens	Wesbar	Display Bag	12
Replacement Parts				
47-99-005	Clearance Light LED #99 Red	Bargman	Bulk	100
401566	Clearance Light LED #99 Red	Wesbar	Clamshell	6

WATERPROOF LED ID LIGHT BARS



- Waterproof LED low profile red light bar
- Meets FMVSS/CMVSS 108 requirements for vehicles 80 in. wide or wider
- Pre-wired, single bullet supply and ring terminal ground, with 60" harness for easy installation
- P2 rated
- 13.54 in. x 1.313 in. x .787 in.



47-106858

Part Number	Description	Brand	Packaging	Master Carton
47-106858	Light Bar LED with Red Lens	Wesbar	Bulk	-
42-106858	Light Bar LED with Red Lens	Wesbar	Litho Box	3

WATERPROOF LED ID LIGHT BARS



- Submersible design with black poly-carbonate base incorporates LED #37 series clearance/marker modules
- Pre-wired (supply and ring terminal ground) for easy installation
- FMVSS/CMVSS 108 P2 compliant for use to meet over 80 in. rear clearance marking requirements
- 17 in. x 1.46 in. x 1.69 in.



42-99-215

Part Number	Description	Brand	Packaging	Master Carton
47-99-215	Light Bar LED with Red Lens	Bargman	Bulk	25
42-99-215	Light Bar LED with Red Lens	Bargman	Blister Card	12
Replacement Parts				
47-37-001	Clearance Light Module LED #37 Red	Bargman	Bulk	400
42-37-401	Clearance Light Module LED #37 Red	Bargman	Clamshell	12
47-37-401	Clearance Light Module LED #37 Red	Bargman	Display Bag	25



47-54-002

LED ID LIGHT BARS WITH REFLEX LENS

- Designed for narrow rail surface mounting
- Features include built-in reflex reflectors and stainless steel grommeted mounting holes
- Pre-wired supply and ground for easy installation
- 15.84 in. x 2.29 in.
- Mounting holes on 14.49 in. centers



47-54-003

Part Number	Description	Brand	Packaging	Master Carton
47-54-002	Light Bar LED with Red Lens	Bargman	Bulk	50
47-54-003	Light Bar LED with Amber Lens	Bargman	Bulk	50



31-99-215

WATERPROOF ID LIGHT BARS



- Submersible design with black poly-carbonate base incorporates incandescent #37 series clearance/marker modules
- FMVSS/CMVSS 108 P2 compliant for use to meet over 80 in. rear clearance marking requirements
- 17 in. x 1.46 in. x 1.69 in.

Part Number	Description	Brand	Packaging	Master Carton
31-99-215	Red ID Bar Incandescent, Mounting Holes Outboard of Lights	Bargman	Blister Card	12
Replacement Parts				
40-37-001	Clearance Light Module #37 Red	Bargman	Bulk	50
203396	Clearance Light Module #37 Red	Wesbar	Blister Card	12



003305



003306

WATERPROOF ID LIGHT BARS



- Sonically-sealed, impact-resistant polycarbonate lens and housing ensure a waterproof module
- Meet or exceed all applicable state and federal regulations specified for vehicles 80 in. wide or wider
- Sealed polycarbonate lamps on 6 in. centers lead to a stainless steel base, completing the best line-up of waterproof light bars available today
- #003305 and #003306 are pre-wired with 60 in. leads and can be mounted in protected areas because of their low profile
- 14-1/2 in. x 1-1/8 in. x 1 in.

Part Number	Description	Brand	Packaging	Master Carton
003305	Light Bar with Red Waterproof Modules and White Bases	Wesbar	Bulk	50
203315	Light Bar with Red Waterproof Modules and White Bases	Wesbar	Display Bag	12
003306	Light Bar with Red Waterproof Modules and Black Bases	Wesbar	Bulk	50

NOTE: Tail Lights, Clearance/Side Marker Lights and ID Light Bars approved for trailer accessory and towing application use. Contact your Horizon Global Representative for details.

WATERPROOF LICENSE PLATE LIGHT



- Waterproof, sealed license plate light with #193 bulb for a variety of mounting applications
- Pigtail available separately
- Meets FMVSS/CMVSS 108 requirements



223210



106310

Part Number	Description	Brand	Packaging	Master Carton
223210	License Light with Bracket White	Wesbar	Bulk	100
Accessories				
40-00-002	2 Wire Pigtail with 6" Wire Lead	Bargman	Bulk	400
44-00-002	2 Wire Pigtail with 6" Wire Lead	Bargman	Display Bag	25
108663	2 Wire Pigtail with 18" Wire Lead	Wesbar	Bulk	100
34-108663	2 Wire Pigtail with 18" Wire Lead	Bargman	Display Bag	25
Replacement Parts				
106310	License Light Module Clear	Wesbar	Bulk	200

30-62-103



34-62-002



LICENSE PLATE LIGHTS #62 SERIES

- ABS body construction
- Can be purchased with or without separate 18-gauge galvanized steel license bracket
- Molded socket protects bulb from road shock and has two wires to eliminate surface ground
- 4 in. x 1-1/2 in. x 2-5/8 in.

Part Number	Description	Brand	Packaging	Master Carton
30-62-003	License Light with Bracket White	Bargman	Bulk	25
34-62-003	License Light with Bracket White	Bargman	Display Bag	25
30-62-103	License Light Less Bracket White	Bargman	Bulk	50
34-62-103	License Light Less Bracket White	Bargman	Display Bag	25
30-62-002	License Light with Bracket Black	Bargman	Bulk	25
34-62-002	License Light with Bracket Black	Bargman	Display Bag	25
30-62-102	License Light Less Bracket Black	Bargman	Bulk	50
34-62-102	License Light Less Bracket Black	Bargman	Display Bag	25
Replacement Parts				
30-62-030	License Plate Bracket	Bargman	Bulk	50
34-62-030	License Plate Bracket	Bargman	Display Bag	25

30-62-000



54206-001

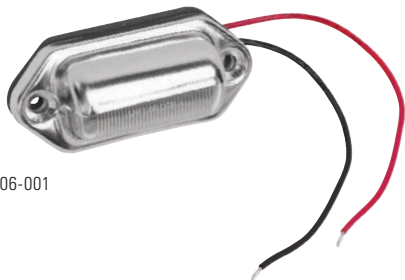

MINI COMPACT LICENSE PLATE LIGHTS

- Illuminators are dirt and moisture resistant
- Housing is chrome plated steel with half shaded white lens
- Mini compact lights feature two wire construction, mounting gasket and screw
- Bullet snap-in light with self-grounding single wire construction
- 2-5/8 in. x 1-1/4 in. x 1 in. - mini compact / LED mini compact
- 1 in. cutout - bullet snap-in

Part Number	Description	Brand	Packaging	Master Carton
30-62-000	Mini Compact Light	Bargman	Bulk	400
34-62-000	Mini Compact Light	Bargman	Display Bag	25
54206-001	LED Mini Compact Light	Bargman	Bulk	144

60-50-001

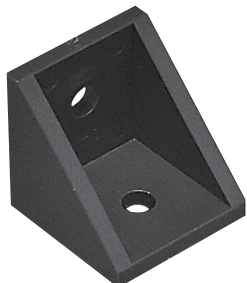

MOUNTING BRACKET

- Dark brown thermo-plastic corner bracket
- .20 in. diameter mounting holes accept up to #10 screws
- 1 in. x 1 in. x 1 in.
- 45° angled

Part Number	Description	Brand	Packaging	Master Carton
60-50-001	Support Mounting Bracket	Bargman	Bulk	1,000



30-62-030



003201

LICENSE PLATE BRACKETS

Part Number	Description	Brand	Packaging	Master Carton
30-62-030	License Plate Bracket 18 Gauge, Galvanized Steel	Bargman	Bulk	50
34-62-030	License Plate Bracket 18 Gauge, Galvanized Steel	Bargman	Display Bag	25
30-72-100	License Plate Bracket 16 Gauge, Zinc Plated	Bargman	-	-
34-72-100	License Plate Bracket 16 Gauge, Zinc Plated	Bargman	Display Bag	25
003201	License Plate Bracket Plastic, Black	Wesbar	Bulk	200
003211	License Plate Bracket Plastic, Black	Wesbar	Bulk	500
003202	License Plate Bracket Plastic, White	Wesbar	Bulk	200
003213	License Plate Bracket Plastic, White	Wesbar	Bulk	500

OBLONG REFLECTORS

- Class "A" acrylic reflector, hermetically sealed
- Two mounting holes
- Optional adhesive fiber back
- 4-3/8 in. x 1-7/8 in.



70-78-010

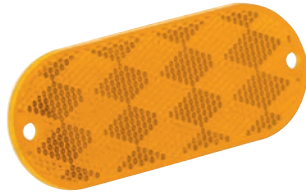

70-78-020

Part Number	Description	Brand	Packaging	Master Carton
70-78-010	Red with Mounting Holes and Adhesive Back	Bargman	Sleeve	25
71-78-010	Red with Mounting Holes and Adhesive Back	Bargman	Clamshell	12
74-78-010	Red with Mounting Holes and Adhesive Back	Bargman	Display Bag	25
70-78-050	Red with Mounting Holes Only	Bargman	Sleeve	25
70-78-020	Amber with Mounting Holes and Adhesive Back	Bargman	Sleeve	25
71-78-020	Amber with Mounting Holes and Adhesive Back	Bargman	Clamshell	12
74-78-020	Amber with Mounting Holes and Adhesive Back	Bargman	Display Bag	25
70-78-060	Amber with Mounting Holes Only	Bargman	Sleeve	25

RECTANGULAR REFLECTORS

- Class "A" acrylic reflector, hermetically sealed
- Adhesive fiber back for instant mounting
- 3-1/4 in. x 1-1/2 in.

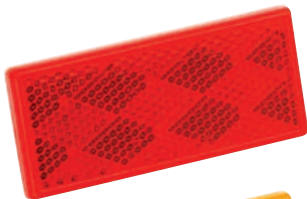

70-71-180



70-71-181

Part Number	Description	Brand	Packaging	Master Carton
70-71-180	Red with Adhesive Back	Bargman	Sleeve	25
74-71-180	Red with Adhesive Back	Bargman	Display Bag	25
003358	Red with Adhesive Back	Wesbar	Clamshell	24
70-71-181	Amber with Adhesive Back	Bargman	Sleeve	25
74-71-181	Amber with Adhesive Back	Bargman	Display Bag	25
003357	Amber with Adhesive Back	Wesbar	Clamshell	24
323357	Amber with Adhesive Back, with Mounting Holes, 4-3/8" x 1-1/4"	Wesbar	-	-
323356	Red with Adhesive Back, with Mounting Holes, 4-3/8" x 1-1/4"	Wesbar	-	-

ROUND REFLECTORS

- Class "A" acrylic reflector, hermetically sealed
- Center mounting hole or adhesive fiber back
- 3-3/16 in. and 2-3/16 in.

70-68-010



70-71-170



70-68-020



Part Number	Description	Brand	Packaging	Master Carton
70-68-010	3-3/16" Red with Center Mounting Hole	Bargman	Bulk	1,000
74-68-010	3-3/16" Red with Center Mounting Hole	Bargman	Display Bag	25
70-71-170	2-3/16" Red with Center Mounting Hole	Bargman	Bulk	1,000
74-71-170	2-3/16" Red with Center Mounting Hole	Bargman	Display Bag	25
70-68-020	3-3/16" Amber with Center Mounting Hole	Bargman	Bulk	1,000
74-68-020	3-3/16" Amber with Center Mounting Hole	Bargman	Display Bag	25
70-71-175	2-3/16" Amber with Center Mounting Hole	Bargman	Bulk	1,000
74-71-175	2-3/16" Amber with Center Mounting Hole	Bargman	Display Bag	25
70-38-010	3-3/16" Red with Adhesive Back	Bargman	Bulk	1,000
74-38-010	3-3/16" Red with Adhesive Back	Bargman	Display Bag	25
70-55-010	2-3/16" Red with Adhesive Back	Bargman	Bulk	1,000
74-55-010	2-3/16" Red with Adhesive Back	Bargman	Display Bag	25
70-38-020	3-3/16" Amber with Adhesive Back	Bargman	Bulk	1,000
74-38-020	3-3/16" Amber with Adhesive Back	Bargman	Display Bag	25
70-55-020	2-3/16" Amber with Adhesive Back	Bargman	Bulk	1,000
74-55-020	2-3/16" Amber with Adhesive Back	Bargman	Display Bag	25

CONSPICUITY REFLECTORS/TAPE

- Reflectors meet or exceed DOT-C and SAE J5941 for reflectivity marking on trucks and trailers
- Reflectors are comparable in light return to the 2 in. x 12 in. reflective tape and hermetically sealed
- 1.10 in. x 12 in.

74-72-040

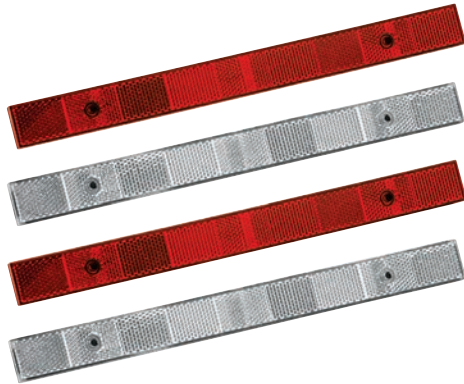

Part Number	Description	Brand	Packaging	Master Carton
74-72-040	Clear and Red with Adhesive Back	Bargman	Poly Bag	25
70-72-020	Clear with Adhesive Back	Bargman	Bulk	144
003387	Clear with Adhesive Back	Wesbar	Poly Bag	12
70-72-030	Red with Adhesive Back	Bargman	Bulk	144
003388	Red with Adhesive Back	Wesbar	Poly Bag	12

SECURITY/UTILITY LIGHTS

- 12 volt surface mounted light is designed to flood light in all directions
- Increased security features to any unit
- Features a 7 in. polycarbonate lens, two wire construction and stainless steel base to resist corrosion
- Designed for years of trouble-free service featuring a gasket between the lens and base, as well as a gasket for mounting
- 8-3/4 in. diameter

40-60-001



40-60-004



Part Number	Description	Brand	Packaging	Master Carton
40-60-001	Security/Utility Light	Bargman	Bulk	30
40-60-004	Security/Utility Light-White Painted Base	Bargman	Bulk	15
Replacement Parts				
30-90-156	Bulb #1156, Single Filament	Bargman	Bulk	1,000

PORCH/UTILITY LIGHTS #78 SERIES

- Compact design is surface mounted with either polypropylene or chrome plated ABS base and either a clear or amber snap-in lens
- A remote switch is required
- Two wire construction, supply and ground
- CSA approved
- 5-15/16 in. x 3-1/2 in. x 2 in.



Part Number	Description	Brand	Packaging	Master Carton
30-78-515	White with Clear Lens	Bargman	Bulk	50
31-78-531	White with Clear Lens	Bargman	Clamshell	6
34-78-515	White with Clear Lens	Bargman	Display Bag	25
30-78-522	Black with Clear Lens	Bargman	Bulk	50
30-78-600	Chrome with Clear Lens	Bargman	Bulk	50
30-78-516	White with Amber Lens	Bargman	Bulk	50
30-78-523	Black with Amber Lens	Bargman	Bulk	50
30-78-517	White with Switch with Clear Lens	Bargman	Display Bag	25
34-78-517	White with Switch with Clear Lens	Bargman	Display Bag	25
30-78-524	Black with Switch with Clear lens	Bargman	Bulk	50
30-78-518	White with Switch with Amber Lens	Bargman	Bulk	50
34-78-518	White with Switch with Amber Lens	Bargman	Display Bag	25
30-78-525	Black with Switch with Amber Lens	Bargman	Bulk	50
Replacement Parts				
30-78-021	Lens #78 Clear	Bargman	Bulk	190
34-78-021	Lens #78 Clear	Bargman	Display Bag	25
30-78-022	Lens #78 Amber	Bargman	Bulk	190
34-78-022	Lens #78 Amber	Bargman	Display Bag	25

INTERIOR LIGHTS #76 SERIES

- Single or double 12 volt interior light with diffused lens optics
- Double light is available with single or dual switch
- Two wire construction, supply and ground
- Features a polypropylene base
- CSA listed/ approved for ceiling mount and specific wall mounts
- Contact your Horizon Global Representative for the specific wall mount applications
- 7.28 in. x 4.33 in. x 1.78 in.
- 11.02 in. x 4.33 in. x 1.78 in.



Part Number	Description	Brand	Packaging	Master Carton
30-76-123	Single Light #76 with Switch	Bargman	Bulk	100
34-76-123	Single Light #76 with Switch	Bargman	Display Bag	25
30-76-223	Double Light #76 with Switch	Bargman	Bulk	100
34-76-223	Double Light #76 with Switch	Bargman	Display Bag	25
30-76-243	Double Light #76 with Dual Switch	Bargman	Bulk	100
34-76-243	Double Light #76 with Dual Switch	Bargman	Display Bag	25
Replacement Parts				
30-90-021	Bulb #921	Bargman	-	-
30-76-028	Lens #76	Bargman	Bulk	100
34-76-028	Lens #76	Bargman	Display Bag	25

INTERIOR DOME LIGHT 5 IN. ROUND WITH CHROME BASE

- Chrome plated steel base with clear polycarbonate lens
- Two wire construction (supply and ground) for easy installation
- Non UL/CSA, suitable for utility use in cargo trailers
- 6.43 in. diameter x 1.65 in.

30-60-004



30-60-005



Part Number	Description	Brand	Packaging	Master Carton
30-60-004	Interior Dome Light 5" Round with Chrome Base	Bargman	Bulk	12
30-60-005	Interior Dome Light 5" Round with Chrome Base with Switch	Bargman	Bulk	12
Replacement Parts				
30-90-156	Bulb #1156	Bargman	Bulk	1,000

BULB SPECIFICATION



30-90-156



30-90-157



108891



30-84-057



30-90-021

Part Number	Bulb Type	Mean Spherical	Rated Amps / Candle Power	Watts	Brand	Packaging	Master Carton
30-90-156	1156	32	2.10	26.880	Bargman	Bulk	1,000
30-90-157	1157	32/3	2.10/0.59	26.880/8.260	Bargman	Bulk	-
108891	193	2	0.33	4.620	Wesbar	Bulk	5,000
30-84-057	2057	32/2	2.10/0.48	26.880/6.720	Bargman	Bulk	1,000
30-90-021	921	21	1.40	17.920	Bargman	Bulk	-

LIGHTING TERMINOLOGY

"Over 80" Combination Tail Lights

These units meet seven or eight DOT-108 lighting requirements when properly mounted. Seven function units meet tail light, stop light, rear turn signal light, rear reflex reflector, rear side marker light, rear side reflex reflector and rear clearance light. The eighth function met is license plate light. Trailers over 80 inches wide require the addition of front Clearance Lights and Rear Identification (ID) Lights. Consult Title 49 – Code of Federal Regulations-Section 571.108 (USA) or Section 108 of the Motor Vehicle Safety Regulations (Canada) for additional compliance requirements.

"Under 80" Combination Tail Lights

These units meet six or seven DOT-108 lighting requirements when properly mounted. Six function units meet tail light, stop light, rear turn signal light, rear reflex reflector, rear side marker light and rear side reflex reflector. The seventh function met is license plate light. Consult Title 49 – Code of Federal Regulations-Section 571.108 (USA) or Section 108 of the Motor Vehicle Safety Regulations (Canada) for additional compliance requirements.

"PC" Rated Clearance/Side Marker Lights

A single unit meets DOT-108 lighting requirements and has been photometrically certified at a specific installation angle to provide both clearance light and side marker light. In most cases, the light will have to be mounted on a 45° angle, Consult Title 49 – Code of Federal Regulations-Section 571.108 (USA) or Section 108 of the Motor Vehicle Safety Regulations (Canada) for additional compliance requirements to meet both functions' requirements with just one unit.

LIGHTING TIPS AND FAQs

Do I have to use a light or can I use a reflector instead?

Lighting and conspicuity requirements are governed by FMVSS and CMVSS 108. Their use is determined by safety and identification requirements.

What regulations apply to the lighting of a trailer or motor coach?

In the USA, FMVSS 108.
In Canada, CMVSS 108 is used.

Why use LED and not Incandescent? The key difference is the way both technologies operate. While both technologies are an acceptable means for vehicle lighting, LED is the stronger technology in energy efficiency, light output, reliability, safety and life expectancy.

Do LED lights have to be mounted differently than Incandescent? No, the FMVSS/CMVSS 108 mounting requirements are the same.

When retrofitting a Bargman 59 or 84/85/86 Series Incandescent light with LED can the old lenses be reused? No, Bargman 59 and 84/85/86 Series LED module kits come with pre-assembled lenses and a simple "plug & play" replacement design.

What does stop/tail/turn mean? How many lights do I need to use to achieve it? Are they the same as "Tail Lights"? Stop/Tail/Turn is a combination rating, meaning a specific light or grouping of lights in an assembly meet the requirements for this named combination. This rating can be achieved using 1 light alone, as long as the light source meets the requirements for the specific application.

Why does Horizon Global offer so many different types and styles of lights for a vehicle? Horizon Global is never satisfied with the status quo and is continually striving to design lights that will meet the designated federal requirements and fit our customer's specific application needs.

When using a Multi-Function Stop/Tail/Turn Light, is a Backup Light function required and does it matter where the Backup Light is located? The requirement for and location of the Backup Light is determined by vehicle type and FMVSS/CMVSS 108 requirements.

Why are some Turn Signal Lights Red and others Amber? Does it matter which color I use? Yes, the color does matter. While both colors are acceptable for turn signals, the color use is primarily driven by the "Stop" Function. When using a multi-function Stop/Turn light, the color must be Red, as required by FMVSS/CMVSS 108 requirements.

What does "Over" or "Under" 80 refer to? This is a reference to a vehicle's width in inches. There are differing FMVSS/CMVSS 108 requirements covering this dimensional reference point.

What are "Over 80" Combination Tail Lights?

These units meet seven or eight lighting requirements, as defined by FMVSS/CMVSS 108.

What are "Under 80" Combination Tail Lights? These units meet six or seven lighting requirements, as defined by FMVSS/CMVSS 108.

What is the difference between Side Marker and Clearance Lights? Side Marker Lights are mounted on the side of a vehicle and are used to define its length. Clearance Lights are mounted on the front and rear of a vehicle and are used to define its width.

What are "PC" Side Marker/Clearance Lights?

These lights meet the FMVSS/CMVSS 108 requirements, for photometric certification as both Clearance and Side Marker Lights when properly mounted.



The symbol is for Wet Location Lights. What does it mean?

Wet Location Lighting products in this catalog are either: "Waterproof/Sealed" or "Submersible" and both are safe to use on marine and other trailers that will be in and around the water or UL listed as suitable for wet location use.

What are Submersible Lights? Submersible lights purposely allow water to enter the light assembly, however a cushion of air forms when water enters the light and will protect the bulbs and electrical connectivity from damage. This natural phenomenon is known as the "Bell Jar Principle". These lights are ideal for boat trailers and utility trailers that will be submersed in water.

What are Waterproof/Sealed Lights? "Waterproof" and "Sealed" mean exactly the same - these lights are completely sealed and will not allow water to enter the inside of the light assembly. Many of our new LED Side/Marker and Tail Lights are completely sealed to prevent water from damaging the circuit board and components associated with LED Technology.

Why are vehicle lights grounded? Vehicle lights are grounded in order to complete the electrical circuit. There are differing ways to ground them to meet various applications.

What is an ID Bar, and can one be used as a multi-function Stop/Tail/Turn as well? An ID Bar is an identification Bar. It consists of 3 lights and is required in order to identify the rear center location on over 80" vehicles. They May Not be used as Multi-Function Lights.

LED HEAVY DUTY AG LIGHTS

- Available in single and dual units, these lights meet all ASABE S279.15 lighting requirements including 4cp to side on amber lens
- Dual lights designed for right hand and left hand horizontal mounting
- Rugged external housing and lens design
- Same mounting foot print hardware and electrical connections as incandescent equivalent
- Brake functions wired with SQ-4 plug
- 6 in. x 5-1/2 in. x 3 in., 10-1/2 in. x 5-1/2 in. x 3 in.



54209-010



54209-015



54209-020



54209-021

Part Number	Description	Packaging	Master Carton
54209-009	Single LED AG Light with 2 Wire Leads - Lens: Rear-Red, Front-Blank	Bulk	6
54209-011	Single LED AG Light with 2 Wire Leads - Lens: Rear-Amber, Front-Amber	Bulk	6
54209-010	Single LED AG Light with 2-Way Plug - Lens: Rear-Red, Front-Blank	Bulk	6
54209-012	Single LED AG Light with 2-Way Plug - Lens: Rear-Amber, Front-Amber	Bulk	6
54209-013	Single LED AG Light with 3 Wire Leads - Lens: Rear-Red, Front-Blank	Bulk	6
54209-015	Single LED AG Light with 3 Wire Leads - Lens: Rear-Amber, Front-Amber	Bulk	6
54209-014	Single LED AG Light with 3-Way Plug - Lens: Rear-Red, Front-Blank	Bulk	6
54209-016	Single LED AG Light with 3-Way Plug - Lens: Rear-Amber, Front-Amber	Bulk	6
54209-019	Dual RH LED AG Light with 3 Wire Leads - Lens: Rear-Red/Amber, Front-Amber/Blank	Bulk	5
54209-005	Dual LH LED AG Light with 3 Wire Leads - Lens: Rear-Amber/Red, Front-Blank/Amber	Bulk	5
54209-020	Dual RH LED AG Light with 3-Way Plug - Lens: Rear-Red/Amber, Front-Amber/Blank	Bulk	5
54209-006	Dual LH LED AG Light with 3-Way Plug - Lens: Rear-Amber/Red, Front-Blank/Amber	Bulk	5
54209-021	Dual RH LED AG Light with 4 Wire Leads - Lens: Rear-Red/Amber, Front-Amber/Blank	Bulk	5
54209-007	Dual LH LED AG Light with 4 Wire Leads - Lens: Rear-Amber/Red, Front-Blank/Amber	Bulk	5
54209-022	Dual RH LED AG Light with 4-Way Square Plug - Lens: Rear-Red/Amber, Front-Amber/Blank	Bulk	5
54209-008	Dual LH LED AG Light with 4-Way Square Plug - Lens: Rear-Amber/Red, Front-Blank/Amber	Bulk	5

NOTE: Reference AG Lighting - Technical for mounting applications.

NOTE: Custom AG lighting and wiring kits are available. Contact your Horizon Global Representative for requirements and minimum annual quantities.

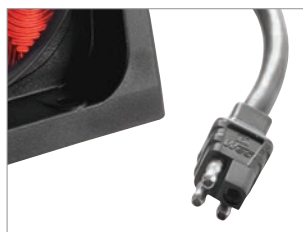

2-Way Plug



3 Wire Leads



4-Way Square Plug



4 Wire Leads



54003-040

LED ECONOMY AG LIGHT KIT

- Left hand and right hand dual light units
- Includes 35 ft. wishbone wire harness, 7-Pin AG plug and tri-plugs
- 5 ft. of convoluted tubing included for protection in critical areas

Part Number	Description	Packaging	Master Carton
54003-040	LED AG Light Kit	Boxed	1
Replacement Parts			
54209-006	Dual LH LED AG Light with 3-Way Plug - Lens: Rear-Amber/Red, Front-Amber/Blank	Bulk	5
54209-020	Dual RH LED AG Light with 3-Way Plug - Lens: Rear-Red/Amber, Front-Amber/Blank	Bulk	5

US Patent D347,903/5,335,155

NOTE: Reference AG Lighting - Technical for mounting applications.



54003-041

LED AG TRANSPORT LIGHT KIT

- Left and right hand dual light units with brake function
- Includes 46 ft. round wishbone cable, (4) 90 lbs. magnets and a 7-Pin round plug

Part Number	Description	Packaging	Master Carton
54003-041	Deluxe AG LED Transport Light Kit with Brake Light Function, 7-Pin	Boxed	1
Replacement Parts			
54209-008	Dual LH LED AG Light with 4-Way Square Plug - Lens: Rear-Amber/Red, Front-Amber/Blank	Bulk	5
54209-022	Dual RH LED AG Light with 4-Way Square Plug - Lens: Rear-Red/Amber, Front-Amber/Blank	Bulk	5
002590	Magnet Kit, 90 lbs. Pull	Poly Bag	12

US Patent D347,903/5,335,155

NOTE: Reference AG Lighting - Technical for mounting applications.



54003-138

LED PEDESTAL MOUNT AG LIGHTS

- Meets ASABE S279, FMVSS-108DOT, and EC requirements
- AMECA certified
- Amber lamps meet 4cp sidelight requirements in horizontal and vertical mounting options
- Custom connector options available
- Lamps are waterproof with 16 wire gage
- Diameter: 4-3/4 in. x Height: 5 in. x Cable Length: 12 in.



Part Number	Description	Packaging	Master Carton
54209-031	Pedestal Mount Single AG LED Light with Amber/Amber	Boxed	24
54209-032	Pedestal Mount Single AG LED Light with Red	Boxed	24
54209-047	Pedestal Mount AG LED Light with Amber	Clamshell	12
54209-048	Pedestal Mount Single AG LED Light with Red	Clamshell	12
54003-137	Economy AG LED Light Kit, 7-Pin, with Pedestal Mount Amber/Amber/Red, Tri-Mold with 35' Wishbone Harness	Boxed	1
54003-138	Deluxe AG LED Transport Kit with Brake Light Function, 7-Pin, Amber/Amber/Red, with 46' Wishbone Harness	Boxed	1



002670

ECONOMY AG LIGHT KIT

- Left hand and right hand dual light units
- Includes 35 ft. wishbone wire harness, 7-Pin AG plug and tri-plugs
- 5 ft. of convoluted tubing included for protection in critical areas

Part Number	Description	Packaging	Master Carton
002670	Standard AG Light Kit	Boxed	1
Replacement Parts			
8260001	Dual AG Light with Amber/Red	Bulk	24
8260101	Dual AG Light with Red/Amber	Bulk	24

US Patent D347,903/5,335,155

NOTE: Reference AG Lighting - Technical for mounting applications.

NOTE: Custom AG lighting and wiring kits are available. Contact your Horizon Global Representative for requirements and minimum annual quantities.



8260501

8260601



8261605

HEAVY DUTY AG LIGHT KITS

- Left hand and right hand dual light units
- Includes 35 ft. wishbone wire harness, 7-Pin AG plug and tri-plugs
- 5 ft. of convoluted tubing included for protection in critical areas

Part Number	Description	Packaging	Master Carton
8260501	Single AG Light 2 Wire with 3-Way Plug - Lens: Rear-Red, Front-Blank	Bulk	24
8260601	Single AG Light 2 Wire with 3-Way Plug - Lens: Rear-Amber, Front-Amber	Bulk	24
8261001	Single AG Light 3 Wire with 3-Way Plug - Lens: Rear-Red, Front-Blank	Bulk	24
8260502	Single AG Light 2 Wire with 2-Way Weatherpack Plug - Lens: Rear-Red, Front-Blank	Bulk	24
8260602	Single AG Light 2 Wire with 2-Way Weatherpack Plug - Lens: Rear-Amber, Front-Amber	Bulk	24
8261002	Single AG Light 3 Wire with 3-Way Weatherpack Plug - Lens: Rear-Red, Front-Blank	Bulk	24
8260001	Dual LH AG Light 3 Wire with 3-Way Plug - Lens: Rear-Amber/Red, Front-Blank/Amber	Bulk	24
8260101	Dual RH AG Light 3 Wire with 3-Way Plug - Lens: Rear-Red/Amber, Front-Amber/Blank	Bulk	24
8261501	Dual LH AG Light 4 Wire with 4-Way Square Plug - Lens: Rear-Amber/Red, Front-Blank/Amber	Bulk	24
8261601	Dual RH AG Light 4 Wire with 4-Way Square Plug - Lens: Rear-Red/Amber, Front-Amber/Blank	Bulk	24
8261605	Dual RH AG Light 4 Wire with 4-Way Weatherpack Plug - Lens: Rear-Red/Amber, Front-Amber/Blank	Bulk	24
Replacement Parts			
30-90-157	Bulb #1157, Double Filament	-	-
802650	Lens Amber, AG Lamp	-	-
802651	Lens Red, AG Lamp	-	-
802652	Insert Black, AG Lamp	-	-



2-Way Weatherpack Plug

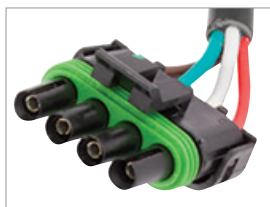

4-Way Weatherpack Plug

AG TRANSPORT LIGHT KIT

- Left and right hand dual light units with brake function
- Includes 46 ft. round wishbone cable, (4) 90 lbs. magnets and either a 7-Pin or 6-Pin round plug



Part Number	Description	Packaging	Master Carton
002675	Deluxe AG Transport Kit with Brake Light Function, 6-Pin	Boxed	1
002676	Deluxe AG Transport Kit with Brake Light Function, 7-Pin	Boxed	1
Replacement Parts			
8261501	Dual AG Light with Amber/Red and Brake Light Function	Bulk	24
8261601	Dual AG Light with Red/Amber and Brake Light Function	Bulk	24
002590	Magnet Kit, 90 lbs. Pull	Poly Bag	12

US Patent D347,903/5,335,155

NOTE: Reference AG Lighting - Technical for mounting applications.

LED WORK LIGHTS

- Perfect for exterior use in AG, horse, livestock, RV, industrial and racing applications
- Environmentally sealed design with aluminum housing and stainless steel mounting stud
- High power, true white 9-36V, 10W light emission
- Circular: 4.5 in. diameter x 1.50 in. depth
- Rectangular: 4 in. x 4 in. x 1.50 in. depth



Part Number	Description	Packaging	Master Carton
54209-001	Circular LED Light, 8 Diodes	Bulk	24
54209-002	Rectangular LED Light, 10 Diodes	Bulk	24
54209-025	Rectangular LED Light, 10 Diodes with Molded 2-Flat Plug	Bulk	24

LED WORK LIGHTS WITH COILED CORD AND MAGNETIC BASE

- Perfect for exterior use in AG, horse, livestock, RV, industrial and racing applications
- Environmentally sealed design with 19 ft. extended coiled cord
- Magnetic base, with protective film, secures in high vibration conditions in a vertical or horizontal position
- Power adapter for 12V outlet with separate on/off switch
- High power, true white 9-36V, 10W light emission
- Circular: 4.5 in. diameter x 1.875 in. depth
- Rectangular: 4 in. x 4 in. x 1.75 in. depth



Part Number	Description	Packaging	Master Carton
54209-017	Circular LED Light, with Cord, Magnetic Base, 8 Diodes	Bulk	24
54209-018	Rectangular LED Light, with Cord, Magnetic Base, 10 Diodes	Boxed	2



TRAILER AND VEHICLE ACCESSORIES

Draw-Tite® has been designing and manufacturing the world's finest trailering products since 1946. That's why it makes sense to use genuine Draw-Tite® products to ensure the integrity of your tow vehicle's rig. Draw-Tite® components are designed and manufactured to work best with other Draw-Tite® products, and all are engineered to the same exacting standards for years of worry-free performance under the most demanding conditions.

Intelligent trailer braking is the key to the success of the Tekonsha® family of braking products. Established in 1964, Tekonsha® technology can be found in some of North America's leading vehicle manufacturers ... a testimony to its superior performance history when it comes to stopping trailers. "No matter what you are towing, Tekonsha® can help you stop it".

BREAKAWAY SYSTEMS

Push To Test Systems	N-2
Standard Systems.....	N-3 - N-4
Switches.....	N-4
Batteries and Cases.....	N-5
Chargers.....	N-5

TRAILER BRAKE PARTS

Electric Trailer Brake Assemblies	N-6
Replacement Parts.....	N-7 - N-10
Magnet Sets	N-8
Nuts and Bolts.....	N-9

WHEEL PROTECTION

Bearing Kits and Protectors	N-9 - N-10
Grease Caps	N-10
Plastic Fenders	N-11

TRAILER ACCESSORIES

Boat Guides	N-12
Marine Grade Carpeting	N-12
Outboard Motor Lock.....	N-12
Wheel Chocks.....	N-12
Safety Chains.....	N-13
D-Rings and Tow Hooks.....	N-13 - N-14
Spare Tire Carriers.....	N-15
Trailer Alignment Tool	N-16

VEHICLE ACCESSORIES

Adjustable Tow Bars	N-14
Hazard Lights.....	N-16

DISCONTINUED PRODUCTS.....N-17 - N-18

PUSH TO TEST BREAKAWAY SYSTEM



50-85-325



5085115
(Bracket Sold Separately)

- Push to Test: LED's indicate fully charged, charging or recharge
- Multi-Stage Integrated Charger provides a fast recharge up to 12.8 volts. Once battery is fully charged, the automatic float mode is designed to provide a continuous charge without overcharging
- Activates trailer brakes upon separation of trailer and tow vehicle
- For use on 1, 2 or 3 axle trailers equipped with electric brakes
- Weather/corrosion resistant, heavy-duty polymer case to protect battery and charger
- Tekonsha® Breakaway Switch with 48 in. lead wires or 7.5 in. lead wires
- 5 Amp-hr battery, battery box dimensions: 4.25 in. x 6.25 in. x 4.125 in.
- 2 or 3 mounting options
- Make sure battery is fully charged prior to towing

Part Number	Description	Packaging	Master Carton
50-85-313	Push to Test Breakaway System for 1 to 3 Axle Trailers with Electric Brakes, 2 Mounting Options, Includes Battery Box, 5 Amp Battery with Push to Test LED Test Meter, Integrated Multi-Stage Charger and 7.5" Breakaway Switch	Litho Box	10
50-85-325	Push to Test Breakaway System for 1 to 3 Axle Trailers with Electric Brakes, 3 Mounting Options, Includes Battery Box, 5 Amp Battery with Push to Test LED Test Meter, Integrated Multi-Stage Charger and 48" Tekonsha Breakaway Switch	Litho Box	10
Accessory			
5085115	Post Mount Bracket	Poly Bag	48

NOTE: 3 and 4 axle trailers require minimum 5 Amp-hr battery. For optimal performance, replacement of breakaway electrical components is recommended every 3 to 5 years.

PUSH TO TEST BREAKAWAY SYSTEM



50-85-320

- Push to Test: LED's indicate fully charged or recharge
- Built in battery charger charges battery when plugged into the tow vehicle
- Breakaway Switch with 7.5 in. or 48 in. lead wires
- 5 Amp-hr battery
- Activates trailer brakes upon separation of trailer and tow vehicle
- For use on 1, 2, or 3 axle trailers equipped with electric brakes
- 2 or 3 mounting options
- Make sure battery is fully charged prior to towing

Part Number	Description	Packaging	Master Carton
50-85-315	Push to Test Breakaway System for 1 to 3 Axle Trailers with Electric Brakes, 2 Mounting Options, Includes Battery Box, 5 Amp Battery with Push to Test LED Test Meter and 7.5" Breakaway Switch and Built-In Charger	Litho Box	10
50-85-320	Push to Test Breakaway System with ABCD charger for 1 to 3 Axle Trailers with Electric Brakes, 3 Mounting Options, Includes Battery Box, 5 Amp Battery with Push to Test LED Test Meter, and 48" Breakaway Switch and Built-In Charger	Litho Box	10
Accessory			
5085115	Post Mount Bracket	Bulk	1

NOTE: 3 and 4 axle trailers require minimum 5 Amp-hr battery. For optimal performance, replacement of breakaway electrical components is recommended every 3 to 5 years.



1026



20010



1028



20015

BREAKAWAY SYSTEMS

- For use on 1, 2, 3 and 4 axle trailers equipped with electric brakes
- These complete systems incorporate the highest quality components in trailer breakaway systems
- Meet or exceed Department of Transportation (DOT) specifications regarding trailer breakaway and holding requirements
- If a breakaway occurs between your tow vehicle and your trailer, the breakaway systems will automatically apply consistent braking power to your trailer brakes
- Quick and easy to install, the systems comes with a weather/ corrosion resistant, heavy-duty polymer case to protect the battery and charger

Part Number	Description	Packaging	Master Carton
For 1 and 2 Axle Trailers with Electric Brakes			
1026	Includes 2018 Polymer Battery Case with A-Frame or Post Mounting Bracket, 2023 Rechargeable Sealed 12v 5 Amp-hr Lead Acid Battery and Terminals and 2005-P Breakaway Switch, Up to 3 Axles	Boxed	4
For 1, 2, 3 and 4 Axle Trailers with Electric Brakes			
2026	Includes 2018 Polymer Battery Case with A-Frame or Post Mounting Bracket, 2023 Rechargeable Sealed 12v 5 Amp-hr Lead Acid Battery and Terminals and 2010-P Breakaway Switch	Boxed	4
20005	Includes 2051 Lockable All Polymer Battery Case with Flat Surface Mounting, 2023 Rechargeable Sealed 12v 5 Amp-hr Lead Acid Battery and Terminals and 2010-P Breakaway Switch	Boxed	4
20010	Includes 20000 Lockable Polymer Battery Case with Weldable Flat Surface Mounting, 2023 Rechargeable Sealed 12v 5 Amp-hr Lead Acid Battery and Terminals and 2010-P Breakaway Switch	Boxed	4
(With Charger)			
For 1 and 2 Axle Trailers with Electric Brakes			
1028	Includes 2018 Polymer Battery Case with A-Frame or Post Mounting Bracket, 2023 Rechargeable Sealed 12v 5 Amp-hr Lead Acid Battery and Terminals, 2005-P Breakaway Switch and 1024 DC-tN-DC Accelerated Battery Charging Device (ABCD), Up to 3 Axles	Boxed	4
(With Multi-Stage Integrated Charger)			
For 1, 2, 3 and 4 Axle Trailers with Electric Brakes			
2028	Includes 2018 Polymer Battery Case with A-Frame or Post Mounting Bracket, 2023 Rechargeable Sealed 12v 5 Amp-hr Lead Acid Battery and Terminals, 2010-P Breakaway Switch and 2024-07 DC-tN-DC Heavy Duty Quick/Maintenance (Multi Stage) Battery Charger	Boxed	4
20015	Includes 2051 Lockable All Polymer Battery Case with Flat Surface Mounting, 2023 Rechargeable Sealed 12v 5 Amp-hr Lead Acid Battery and Terminals, 2010-P Breakaway Switch and 2024-07 DC-tN-DC Heavy Duty Quick/Maintenance (Multi Stage) Battery Charger	Boxed	4
20020	Includes 20000 Lockable Polymer Battery Case with Weldable Flat Surface Mounting, 2023 Rechargeable Sealed 12v 5 Amp-hr Lead Acid Battery and Terminals, 2010-P Breakaway Switch and 2024-07 DC-tN-DC Heavy Duty Quick/Maintenance (Multi Stage) Battery Charger	Boxed	4

NOTE: 3 and 4 axle trailers require minimum 5 Amp-hr battery. For optimal performance, replacement of breakaway electrical components is recommended every 3 to 5 years.



50-85-302

BREAKAWAY SYSTEM

- Activates trailer brakes upon separation of trailer and tow vehicle
- For use on 1, 2 or 3 axle trailers equipped with electric brakes
- Weather/corrosion resistant, heavy-duty polymer case to protect battery and charger
- Breakaway Switch with 7.5 in. lead wires
- 5 Amp/hr Battery, battery box dimensions: 5 in. x 4.125 in. x 4 in.
- Flat surface mounting, optional post mount bracket available
- Make sure battery is fully charged prior to towing

Part Number	Description	Packaging	Master Carton
50-85-302	Breakaway System	Bulk	10
50-85-312	Breakaway System with Charger	Bulk	10
Accessory Part			
5085115	Post Mount Bracket	Bulk	



50-85-007

BREAKAWAY SWITCHES

- Completely sealed breakaway switches to automatically set trailer brakes in case of accidental trailer breakaway
- Required by law in some states
- Emergency use only, not to be used to lock brakes when parked or stored

Part Number	Description	Packaging	Master Carton
50-85-007	Breakaway Switch with 48" Wires with Cable and Nylon Pin Assembly	Bulk	50
54-85-007	Breakaway Switch with 48" Wires with Cable and Nylon Pin Assembly	Poly Bag	25
2010-B125	Breakaway Switch with 48" Wires with Cable and Nylon Pin Assembly	Bulk	125
2010-P	Breakaway Switch with 48" Wires with Cable and Nylon Pin Assembly	Clamshell	20
2005-B120	Breakaway Switch with 48" Wires with Cable and Nylon Pin Assembly, for use with 1-3 Axle Trailers	Bulk	120
2005-P	Breakaway Switch with 48" Wires with Cable and Nylon Pin Assembly, for use with 1-3 Axle Trailers	Clamshell	20
2009-B60	Breakaway Switch with 48" Wires with Cable and Brass Pin Assembly	Bulk	60
2009-P	Breakaway Switch with 48" Wires with Cable and Brass Pin Assembly	Clamshell	20
Replacement Parts			
50-85-002	48" Replacement Cable and Nylon Pin Assembly, for 50-85-007 Switch	Bulk	100
54-85-002	48" Replacement Cable and Nylon Pin Assembly, for 50-85-007 Switch	Poly Bag	25
2010-A	48" Replacement Cable and Nylon Pin Assembly, for 2010 Switch	Bulk	250
2010-A-P	48" Replacement Cable and Nylon Pin Assembly, for 2010 Switch	Clamshell	10
2005-A	48" Replacement Cable and Nylon Pin Assembly, for 2005 Switch	Bulk	200
2009-A	48" Replacement Cable and Brass Pin Assembly, for 2009 Switch	Bulk	250
2009-A-P	48" Replacement Cable and Brass Pin Assembly, for 2009 Switch	Clamshell	10



2010-B125



2005-B120



2009-B60

NOTE: Most states require breakaway switch with separate power supply when towing a trailer



2023

SEALED LEAD ACID BATTERY

- 12v, sealed lead acid battery for use with breakaway systems on single, tandem and tri-axle trailers equipped with electric brakes
- Battery requires periodic recharging to maintain optimum performance

Part Number	Description	Packaging	Master Carton
2023	5 Amp-Hr Sealed Battery	Bulk	5
2023-X	5 Amp-Hr Sealed Battery	Boxed	5

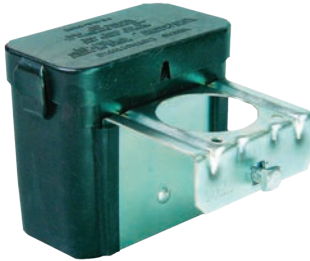

2018

BATTERY CASES

- Rust-proof heavy duty polymer cases protect battery and charger from elements and corrosion

Part Number	Description	Packaging	Master Carton
2018	Battery Case, One-Bolt Installation on Jackpost or A-Frame, Includes Mounting Bracket	Bulk	20
2051	Battery Case, Four-Bolt Installation on Flat Surface, Lockable	Bulk	20
20000	Battery Case, Two-Bolt or Weldable Installation on Flat Surface, Lockable	Boxed	20



20000

BATTERY CHARGERS

- For all 12v battery systems with a 4 Amp-hr minimum output
- Temperature compensated design provides continuous recharge with automatic float mode feature to prevent overcharging
- Ideal for seasonal storage and maintenance of recreational vehicles, motorcycles, snowmobiles, lawn tractors, and more
- Patent pending

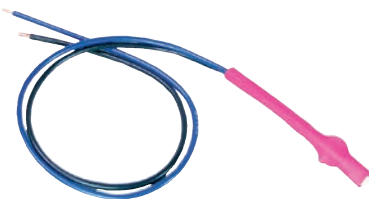

50-85-104

Part Number	Description	Packaging	Master Carton
50-85-104	DC-tN-DC Accelerated Battery Charging Device (ABCD), Returns Trailer Breakaway System Batteries to Max Potential	Bulk	10
1024	DC-tN-DC Accelerated Battery Charging Device (ABCD), Returns Trailer Breakaway System Batteries to Max Potential	Clamshell	10
2024-07	DC-tN-DC Heavy Duty Multi Stage/Maintenance Charger, Designed to Fit Securely in Breakaway Battery Cases	Bulk	10
2024-07-S	DC-tN-DC Heavy Duty Multi Stage/Maintenance Charger, Designed to Fit Securely in Breakaway Battery Cases	Clamshell	10
2025-09	AC-tN-DC Multi Stage Maintenance Charger, Automatic Float Mode Prevents Overcharging	Clamshell	20



2024-07



2025-09

SELF-ADJUSTING ELECTRIC TRAILER BRAKE ASSEMBLIES

- Replaces Dexter Electric Trailer Brake Assemblies
- Self Adjusting
- Units are assembled
- Replace in pairs
- Assemblies include: Backing Plate, Shoe and Linings, Magnets, Actuating Lever and Spring Hardware

54801-005



Part Number	Description	Packaging	Master Carton
54801-005	10 x 2 1/4 Right Hand Brake Assembly - Self-Adjusting	Boxed	1
54801-006	10 x 2 1/4 Left Hand Brake Assembly - Self-Adjusting	Boxed	1
54801-007	12 x 2 Right Hand Brake Assembly - Self-Adjusting	Boxed	1
54801-008	12 x 2 Left Hand Brake Assembly - Self-Adjusting	Boxed	1

54801-006



ELECTRIC TRAILER BRAKE ASSEMBLIES

- Replaces Dexter Electric Trailer Brake Assemblies
- Units are assembled
- Assemblies include: Backing Plate, Shoe and Linings, Magnets, Actuating Lever, Adjusting Screw and Spring Hardware

54801-003



Part Number	Description	Packaging	Master Carton
54801-001	10 x 2-1/4 Right Hand Brake Assembly	Boxed	1
54801-002	10 x 2-1/4 Left Hand Brake Assembly	Boxed	1
54801-003	12 x 2 Right Hand Brake Assembly	Boxed	1
54801-004	12 x 2 Left Hand Brake Assembly	Boxed	1
54801-023	10 x 2-1/4 Right Hand Brake Assembly	Boxed	1
54801-024	10 x 2-1/4 Left Hand Brake Assembly	Boxed	1
54801-025	12 x 2 Right Hand Brake Assembly	Boxed	1
54801-026	12 x 2 Left Hand Brake Assembly	Boxed	1

54801-004



**ADJUSTING SCREW KIT
(SPRING AND SCREW ASSEMBLY)**

Part Number	Description	Packaging	Master Carton
5404	10 x 2 1/4 AL-KO	Clamshell	10
	10 x 1 5/8 Hayes		
	10 x 1 1/2 Dexter		
	10 x 2 1/4 Hayes		
	10 x 2 1/4 Dexter		
	10 x 2 1/4 Fayette		
	10 x 2 1/4 Aimco		
	12 x 2 AL-KO		
	12 x 2 Hayes and		
	12 x 2 Hayes Centerline		
	12 x 2 Dexter and		
	12 x 2 Dexter 7K		
	12 x 2 Fayette		
	12 x 2 Aimco		
12 x 2 Foreman			

HOLD DOWN KIT (AXLE SET)

Part Number	Description	Packaging	Master Carton
5353	10 x 2 1/4 AL-KO	Clamshell	10
	10 x 2 1/4 Hayes		
	10 x 2 1/4 Dexter		
	10 x 2 1/4 Fayette		
	10 x 2 1/4 Aimco		
	12 x 2 AL-KO		
	12 x 2 Hayes and		
	12 x 2 Hayes Centerline		
	12 x 2 Dexter and		
	12 x 2 Dexter 7K		
	12 x 2 Fayette		

**BEARING SET
(14276 CUP, 14125A CONE)**

Part Number	Description	Packaging	Master Carton
5508	12 x 2 Dexter 6K and 7K 865 Hub (Out) 12 x 2 AL-KO 8 Hole 865 Hub (Out)	Clamshell	10

**BEARING SET
(L44610 CUP, L44649 CONE)**

Part Number	Description	Packaging	Master Carton
5502	7 1/4 x 1 1/4 Hayes (In and Out)	Clamshell	10
	7 1/4 x 1 1/4 Foreman (In and Out)		
	7 x 1 1/4 Dexter BTL (In and Out)		
	7 x 1 1/4 Dexter BTR (In and Out)		
	7 1/4 x 1 1/4 Fayette (In and Out)		
	7 1/4 x 1 1/4 Foreman (In and Out)		
	10 x 1 5/8 Hayes (Out)		
	10 x 1 1/2 Dexter (Out)		
	10 x 2 1/4 AL-KO (Out)		
	10 x 2 1/4 Hayes (Out)		
	10 x 2 1/4 Dexter (Out)		
	10 x 2 1/4 Fayette (Out)		
	10 x 2 1/4 Foreman (Out)		

RETURN SPRING SET (AXLE SET)

Part Number	Description	Packaging	Master Carton
5305	10 x 2 1/4 Hayes (Dual Retractor - Prior to May 1977)	Clamshell	10
	10 x 2 1/4 Dexter		
	10 x 2 1/4 Aimco		
	10 x 2 1/4 Foreman		
	12 x 2 Aimco		
	12 x 2 Dexter (Dual Retractor) and 12 x 2 Dexter 7K		
5307	12 x 2 Foreman	Clamshell	10
	12 x 2 AL-KO		
	12 x 2 Hayes		
	12 x 2 Dexter (Single Retractor)		
	12 x 2 Fayette		

**SHOE AND LINING KITS
(WHEEL SET)**

Part Number	Description	Packaging	Master Carton
5000-DX	12 x 2 Dexter	Boxed	10
	12 x 2 Fayette (Bonded Shoes)		
	12 x 2 Aimco		
	12 x 2 Foreman		
5003	10 x 2 1/4 Dexter	Boxed	10
5010	12 x 2 Dexter 7K	Boxed	10
6004	10 x 2 1/4 AL-KO	Boxed	10
	10 x 2 1/4 Hayes		
6005	12 x 2 AL-KO	Boxed	10

**BEARING SET
(L68111 CUP, L68149 CONE)**

Part Number	Description	Packaging	Master Carton
5505	10 x 2 1/4 AL-KO (In)	Clamshell	10
	10 x 2 1/4 Fayette (In) (After 1972)		
	10 x 2 1/4 Hayes (In) (After 1972)		
	10 x 2 1/4 Dexter (In) (After Dec. 1983)		
	12 x 2 Foreman (In)		
	12 x 2 AL-KO (In) 6 and 8 Hole		

**BEARING SET
(L44610 CUP, L44649 CONE)**

Part Number	Description	Packaging	Master Carton
5507	10 x 1 5/8 Hayes (In)	Clamshell	10
	10 x 1 1/2 Dexter (In)		
	12 x 2 Hayes (Out)		
	and 12 x 2 Hayes Centerline (Out)		
	12 x 2 Dexter (Out)		
	12 x 2 Fayette (Out)		
	12 x 2 Foreman (Out)		

**BEARING SET
(15245 CUP, 15123 CONE)**

Part Number	Description	Packaging	Master Carton
5509	12 x 2 Dexter 6K and 7K UTG Hub (Out) 12 x 2 AL-KO 6 and 8 Hole (865 Small)	Clamshell	10

BEARING SET (25520 CUP, 25580 CONE)

Part Number	Description	Packaging	Master Carton
5503	12 x 2 AL-KO (In) 12 x 2 Hayes (In) and 12 x 2 Hayes Centerline (In) 12 x 2 Dexter (In) and 12 x 2 Dexter 7K (In) 12 x 2 Fayette (In) 12 x 2 Foreman (In) 12 x 2 AL-KO (In) 6 and 8 Hole	Clamshell	10

GREASE CAP (AXLE SET)

Part Number	Description	Packaging	Master Carton
5651	7 x 1 1/4 Dexter 10 x 2 1/4 AL-KO 10 x 1 5/8 Hayes 10 x 1 1/2 Dexter 10 x 2 1/4 Hayes 10 x 2 1/4 Dexter 10 x 2 1/4 Fayette 10 x 2 1/4 Foreman	Clamshell	10
5652	12 x 2 AL-KO (Small Bore) 12 x 2 Hayes and 12 x 2 Hayes Centerline 12 x 2 Dexter and 12 x 2 Dexter 7K 12 x 2 Fayette 12 x 2 Foreman	Clamshell	10
6658	12 x 2 AL-KO (Large Bore)	Clamshell	10

MAGNET RETAINING RING

Part Number	Description	Packaging	Master Carton
5120TEK	10 x 1 5/8 Hayes 10 x 2 1/4 Hayes (Old Style) 12 x 2 Hayes (Old Style)	Clamshell	10

MAGNET SETS

Part Number	Description	Wire Color	Length (in.)	Width (in.)	Thickness (in.)	Packaging	Master Carton
5101-HA	Hayes 10 x 1 5/8 Hayes 10 x 2 1/4 Hayes 12 x 2 (All - Replaces in pairs) (All - After Late 1994)	Green	3-1/8	2	15/16	Boxed	20
5106	Dexter 10 x 2 1/4 Hayes 10 x 2 1/4 (After Mid 1987) Hayes 10 x 1 5/8 (After Mid 1987) Trailer Pac 102 Tow Craft 1103-100-017	Green	3-1/8	2-3/8	15/16	Boxed	20
5109	Dexter 12 x 2 Hayes 12 x 2 (After Late 1987) Trailer Pac 103 Tow Craft 1103-100-018	Green	3-1/8	2	15/16	Boxed	20
5113	Dexter 10 x 1 1/2 (Prior to Mid 1988) Dexter 7 x 1 1/4 (After April 1990)	White	2-1/16	1-15/16	3/4	Boxed	20
5114	Dexter 12 x 2, 7K Axles	Black	3-1/8	2	15/16	Boxed	20
6106	AL-KO Kober 10 x 2 1/4	Green	3-1/8	2-3/8	15/16	Boxed	20
6109	AL-KO Kober 12 x 2, 6K and 7K	Green	3-1/8	2	15/16	Boxed	20

GREASE SEAL (AXLE SET)

Part Number	Description	Packaging	Master Carton
5602	7 1/4 x 1 1/4 Hayes	Clamshell	10
5603	7 x 1 1/4 Dexter (BTR)	Clamshell	10
5604	10 x 1 5/8 Hayes 10 x 2 1/4 AL-KO 10 x 2 1/4 Hayes 10 x 2 1/4 Dexter 10 x 2 1/4 Fayette	Clamshell	10
5605	12 x 2 Hayes and 12 x 2 Hayes Centerline 12 x 2 Fayette 12 x 2 AL-KO*	Clamshell	10
5606	12 x 2 Dexter (Prior 1997) and 12 x 2 Dexter 7K (Prior 1997)	Clamshell	10
5607	10 x 1 1/2 Dexter	Clamshell	10
5608	12 x 2 Dexter (After 1997 - A Series Only) and 12 x 2 Dexter 7K (After 1997 - A Series Only)	Clamshell	10
6604 / 5604	10 x 2 1/4 AL-KO	Clamshell	10
6605 / 5605	12 x 2 AL-KO*	Clamshell	10

WIRE CLIP

Part Number	Description	Packaging	Master Carton
5122	10 x 1 1/2 Dexter 12 x 2 1/4 Dexter 12 x 2 Dexter	Clamshell	10

MAGNET RETAINING CLIP

Part Number	Description	Packaging	Master Carton
5121TEK	10 x 2 1/4 Dexter 12 x 2 Dexter 12 x 2 Dexter 7K 10 x 2 1/4 Hayes (New Style) 12 x 2 Hayes (New Style)	Clamshell	10



WB100 0700

WHEEL BEARING KITS

- Designed to fit most hubs used on boat, utility, snowmobile, and RV trailers
- Kit includes 2 bearing cones, 2 bearing cups, grease seal, and cotter pin

Part Number	Spindle Outer Diameter (in.)	Hub Diameter (in.)	Packaging	Master Carton
WB100 0700	1	1.980	Boxed	6
WB106 0700	1-1/16	1.980	Boxed	6
WB138T0700*	1-3/8 x 1-1/16	1.980	Boxed	6

*Applies to tapered axle applications



5508

5509

5505

5507

BEARING SETS

- Includes cup and cone

Part Number	Cup	Cone	Packaging	Master Carton
5508	14276	14125A	Clamshell	10
5509	15245	15123	Clamshell	10
5503	25520	25580	Clamshell	10
5502	L44610	L44649	Clamshell	10
5507	LM67010	LM67048	Clamshell	10
5505	L68111	L68149	Clamshell	10



5780TEK

5787

WHEEL NUTS AND BOLTS

- Secures wheel to brake drum
- Set of 5

Part Number	Description	Packaging	Master Carton
5780TEK	13/16 Wheel Nut, 1/2 - 20	Clamshell	10
5787	Wheel Bolt, 1/2 - 20	Clamshell	10



5720

BRAKE ASSEMBLY MOUNTING BOLTS

Part Number	Description	Packaging	Master Carton
5720	3/8" Brake Assembly Mounting Bolt, Used on 5 Bolt Mounting Patterns	Clamshell	10
5721	7/16" Brake Assembly Mounting Bolt, Used on 4 Bolt Mounting Patterns	Clamshell	10



5774

5775

SPINDLE NUT KITS

- Secures brake hardware on spindle axles

Part Number	Description	Packaging	Master Carton
5774	Spindle Nut Kit, Standard Washer, 1" - 14 Spindle	Clamshell	10
5775	Spindle Nut Kit, D Type Washer, 1" - 14 Spindle	Clamshell	10



BPC1980604

BEARING PROTECTORS

- Protects wheel bearings from the elements during all trailer operations
- Automatically maintains the correct internal pressure – cannot damage seals
- Chrome-plated steel construction
- Sold in pairs and are available in bulk or full color display packages
- Some models include vinyl cover (see chart)

Part Number	Description	Hub Diameter (in.)	Packaging	Master Carton
BPC1980604	Bearing Protector with Covers	1.980	Clamshell	6
BP198S0304	Bearing Protector	1.980	Bulk	56
BP244S0304	Bearing Protector	2.441	Bulk	64
BP244S0604	Bearing Protector	2.4411	Clamshell	6
BB19800112	Bearing Protector Covers, (2 Pack)	1.980	Poly Bag	12

GREASE CAPS

A = Flange Diameter (OD) **B = Crown Height** **C = Flange Length** **D = Overall Height**

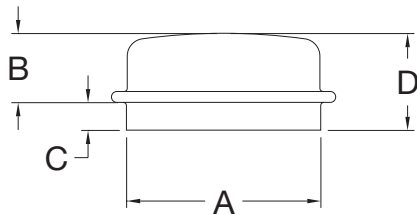

1500 Series

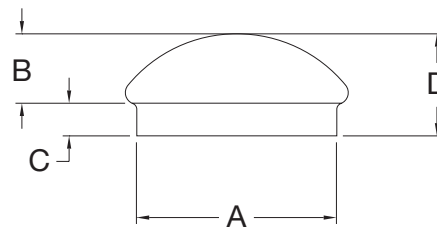

1600 Series

Part Number	Mat. Gauge	A Flange Diameter (in.)	B Crown Height (in.)	C Flange Length (in.)	D Overall Height (in.)	Packaging	Master Carton
1500 Series							
001501*	22	1.786	0.630	0.270	0.890	Boxed	500
-	22	1.786	0.880	0.280	1.160	Boxed	500
001503*	22	1.786	1.160	0.375	1.535	Boxed	500
001523	20	1.943	0.690	0.310	1.000	Boxed	500
001524	20	1.943	1.040	0.340	1.380	Boxed	500
001505*	22	1.968	0.780	0.375	1.156	Boxed	500
001521	20	1.988	0.750	0.220	1.030	Boxed	500
001520*	22	2.446	1.030	0.313	1.340	Boxed	300
001515*	20	2.567	1.080	0.281	1.360	Boxed	300
001526	20	2.722	1.130	0.312	1.440	Boxed	300
001531	16	3.155	1.430	0.370	1.800	Boxed	300
1600 Series							
100235*	16	2.333	0.840	0.370	1.210	Boxed	64
001601	16	2.333	0.910	0.370	1.281	Boxed	1
001604	16	2.446	0.880	0.280	1.160	Boxed	1
001605	16	2.722	1.030	0.310	1.340	Boxed	1
001609	16	3.125	1.010	0.296	1.310	Boxed	300
001607	16	3.155	1.160	0.218	1.375	Boxed	1
001602	16	3.255	0.610	0.530	1.145	Boxed	300

NOTE: All shown standards

*Zinc-plated for corrosion resistance

PLASTIC FENDERS

PLASTIC FENDERS

High density polyethylene (HDPE) fenders are injection molded and corrosion proof with impact resistant, 300 lbs. capacity. Fender's molded-in color are scratch proof and feature a built-in skirt and optional integral step pad.

- Handles temperature extremes
- Mounting slots
- See diagrams below for specific fender measurements



Style B - Top Step



Style C - Top Step



Style D - Top Step and Side Steps

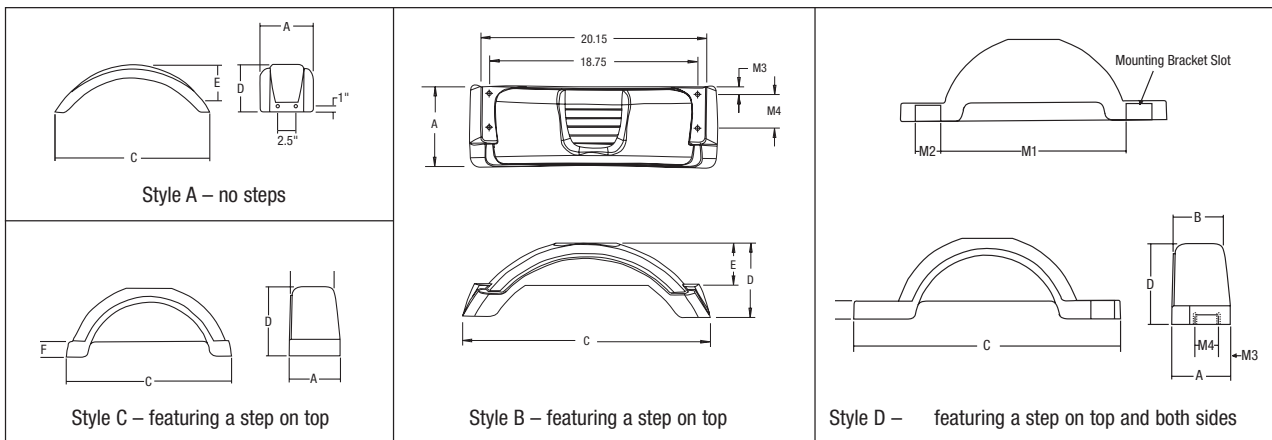

Part Number White	Part Number Black	Part Number Silver	Tire Size (in)	Measurements (See Diagram)										Packaging	Master Carton
				A (in.)	B (in.)	C (in.)	D (in.)	E (in.)	F (in.)	M (1) (in.)	M (2) (in.)	M (3) (in.)	M (4) (in.)		
Style A															
008540*	008550*	-	8 - 12	7.000	-	20.25	6.250	4.620	-	-	-	2.250	2.500	Bulk	1
Style B															
008549	008559	-	8 - 12	7.350	-	22.30	6.500	3.750	2.180	-	-	0.075	3.000	Bulk	1
Style C															
008541*	008551*	008561	8 - 12	7.350	7.350	21.80	6.500	3.750	2.180	-	-	2.430	2.500	Bulk	1
008542	-	-	12	7.510	23.91	8.770	2.500	-	2.750	-	-	-	-	Bulk	1
008543	008553	008563	13	9.000	7.700	29.25	12.00	-	2.750	-	-	-	-	Bulk	1
-	008554	008564	14	9.700	8.000	31.30	12.75	-	3.000	-	-	-	-	Bulk	1
Style D (US Patent D3)															
008572	008582	008592	12	7.500	6.900	33.50	8.750	-	2.500	22.70	4.000	1.500	3.000	Bulk	1
008573	008583	008593	13	9.000	7.700	40.00	12.00	-	2.750	28.00	4.000	2.120	3.750	Bulk	1
508573	-	-	13	9.000	7.700	40.00	12.00	-	2.750	28.00	4.000	2.120	3.750	Bulk	1
008574	008584	008594	14	9.700	8.000	43.40	12.75	-	3.000	30.00	4.000	2.120	3.750	Bulk	1
508574	-	-	14	9.700	8.000	43.40	12.75	-	3.000	30.00	4.000	2.120	3.750	Bulk	1
008575	008585	008595	15	10.25	6.700	45.00	14.85	-	3.000	34.00	4.000	2.120	3.750	Bulk	1



BGR20 0101

BOAT GUIDES

- Boat guides help you visually guide your boat onto your trailer
- High-strength super gripper mounting brackets attach firmly above and below the trailer frame
- Easy bolt-on mounting fits trailer frames up to 3 in. x 5 in. high
- Adjustable to provide optimum fit to any hull design
- Sold in pairs

Part Number	Description	Upright Height (in.)	Packaging	Master Carton
GB44 0101	Non-Marring, Marine Grade PVC Tubing	44	Boxed	1
GB150 0100	Non-Marring, Marine Grade PVC Tubing	50	Boxed	1
BGR20 0101	Steel Construction with Non-Marring Cushioned Rollers	20	Boxed	1
Accessory Part				
500358	Cap for BGR20 0101		Poly Bag	50



CR8008

MARINE GRADE CARPETING

- Marine grade carpeting allows the do-it-yourselfer to replace worn and dirty carpet on bunk trailers
- The carpet protects your boat investment by reducing scratching on the hull and keeps it in like-new condition
- Individual rolls are shrink-wrapped for shelf display

Part Number	Description	Packaging	Master Carton
CR8008	Bunk Carpeting, Black, 8" x 144"	Sleeve	8
CR8012	Bunk Carpeting, Black, 12" x 144"	Sleeve	8



OML 0127

OUTBOARD MOTOR LOCK

- Heavy-duty barrel key lock mechanism for maximum security
- Foam filler insert reduces noise and vibration
- Mounts on most outboard motors

Part Number	Description	Packaging	Master Carton
OML 0127	Outboard Motor Lock	Boxed	6



7000100

WHEEL CHOCKS

- Made from high impact polymer
- Reduces the risk of trailer roll
- Fits most trailer wheels

Part Number	Description	Packaging	Master Carton
7000100	Wheel Chocks	Litho Box	6

SAFETY CHAINS

SAFETY CHAINS

- Safety chains are required by law in most states
- Cross chains when towing for added safety
- All chains conform to J684.6.3.4 SAE standards



CHA0030140



CHA0070324



63035



63451

Part Number	Description	Grade	Size (in.)	Length (in.)	Chain End	Hook Size (in.)	Finish	Capacity (lbs.)	Packaging	Master Carton
CHA0010140	Proof Coil Chain	30	1/4	24	Safety Hook	7/16	Clear Zinc	5,000	Clamshell	4
CHA0010340	Proof Coil Chain	30	1/4	24	Safety Hook	7/16	Clear Zinc	5,000	Barrel	150
CHA0020324	Transport Chain	70	1/4	36	Clevis Hook	1/4	Yellow Zinc	12,600	Barrel	100
CHA0030140	Test Chain	43	1/4	24	Safety Hook	7/16	Clear Zinc	7,800	Clamshell	4
CHA0040324	Transport Chain	70	5/16	36	Clevis Hook	5/16	Yellow Zinc	18,800	Barrel	60
CHA0050324	Transport Chain	70	5/16	42	Clevis Hook	5/16	Yellow Zinc	18,800	Barrel	50
CHA0060324	Transport Chain	70	3/8	36	Clevis Hook	3/8	Yellow Zinc	26,400	Barrel	50
CHA0070324	Transport Chain	70	1/2	42	Clevis Hook	1/2	Yellow Zinc	45,200	Barrel	20
63034	Safety Chain	-	-	72	S-Hooks (Both Ends)	-	Clear Zinc	2,000	Clamshell	2
63035	Safety Chain	-	-	72	Quick Links (Both Ends)	-	Clear Zinc	5,000	Clamshell	2
5592	Proof Coil Chain	-	1/4	72	Straight Link	-	Clear Zinc	3,500	Boxed	1
2489	Machine Chain	-	-	30	Straight Link	-	Clear Zinc	5,000	Boxed	1
63451	Proof Coil Chain	30	1/2	35	Clevis Hook	3/8	Clear Zinc	26,400	Boxed	4



63024



63025



63026



63027

D-RINGS

Part Number	Description	Work Load (lbs.)	Max Load (lbs.)	Packaging	Master Carton
63024	1/2" Forged D-Ring with Mounting Bracket, Yellow Zinc	4,000	12,000	Poly Bag	40
63025	5/8" Forged D-Ring, with Weld-On Mounting Bracket, 3/8" Thick c1045 Material	6,000	18,000	Poly Bag	25
63026	3/4" Forged D-Ring, with Weld-On Mounting Bracket, 3/8" Thick c1045 Material	8,833	26,500	Poly Bag	20
63027	1" Forged D-Ring, with Weld-On Mounting Bracket, 3/8" Thick c1045 Material	15,587	46,760	Poly Bag	15
63028	5/8" Forged D-Ring, with Weld-On Mounting Bracket, 1" x 5" x 6" Thick c1045 Material	15,587	46,760	Poly Bag	10

44155



CLEVIS HOOK

Part Number	Description	Packaging	Master Carton
44155	Grade 43, Clevis Slip with Latch, 5/16"	Bulk	10

74700

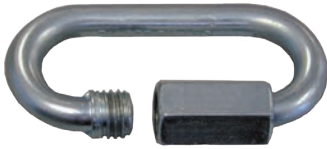

QUICK LINK

Part Number	Description	Packaging	Master Carton
74700	7,000 lbs. 5/16" Safety Chain Quick Link	Bulk	200

JC1000300



J-CLIP

Part Number	Description	Packaging	Master Carton
JC1000300	J-Clip for Safety Chain	Bulk	200

34141



SAFETY CHAIN LOOPS

Part Number	Description	Packaging	Master Carton
4234	2,000 lbs. Class I Safety Chain Loop	Boxed	1
1962	5,000 lbs. Class II/III Safety Chain Loop	Boxed	1
34141	10,000 lbs. Class IV Safety Chain Loop	Boxed	10

63180



5,000 LBS. ADJUSTABLE TOW BARS

- Light weight, only 31 lbs.
- Arms adjust from 26 in. to 41 in. for universal fit
- Tow bar mounting brackets bolt securely to vehicle bumper - (almost all applications will require a custom fabricated bracket due to bumper design)
- Heavy duty quick latch A-Frame coupler fits 2 in. ball
- Tow bar comes assembled, complete with installation instructions
- Some states require the use of double safety chains
- Black powder coat finish
- Total weight of towed vehicle must not exceed 5,000 lbs., or must not exceed the weight of the towing vehicle

63180 - Mounting Brackets

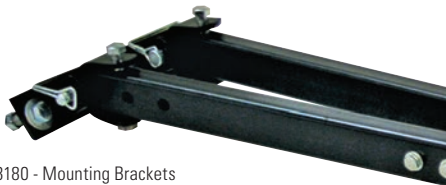

63181



63180 - Adjustable Arms

Part Number	Description	Packaging	Master Carton
63180	Adjustable Tow Bar, 5,000 lbs. GVW, Includes Mounting Brackets	Litho Box	1
63181	Adjustable Tow Bar, 5,000 lbs. GVW, Includes Mounting Brackets with Bolt Together 2-Piece Adjustment Arms	Litho Box	1
Accessories			
40604	Heavy Duty Safety Chain Kit for Tow Bars, Class III Chains Rated at 5,000 lbs. GTW	Boxed	1
40602	Tow Bar Bumper Bracket Kit	Boxed	1
2471	1/2" Wire Lock Pin for Tow Bar Brackets	Boxed	1

SPARE TIRE CARRIERS

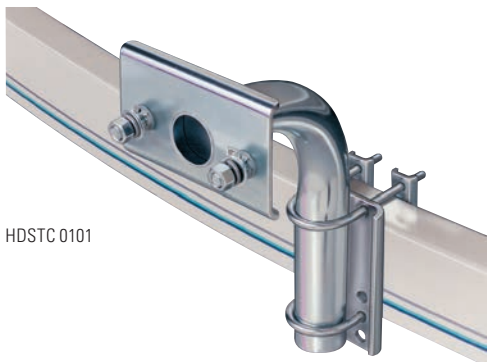

HDSTC 0101

HEAVY DUTY SPARE TIRE CARRIER

- Fits most 4, 5 and 6 lug wheels - up to 16-1/2 in.
- Provides 4-3/4 in. lift and over 7 in. of offset to mount tire up and out of the way
- Zinc-plated to resist corrosion
- Easy bolt-on installation, no cutting or drilling required
- Fits trailer tongue up to 3 in. wide by 5 in. high
- All mounting hardware and instructions included

Part Number	Description	Packaging	Master Carton
HDSTC 0101	Heavy Duty Spare Tire Carrier	Boxed	4

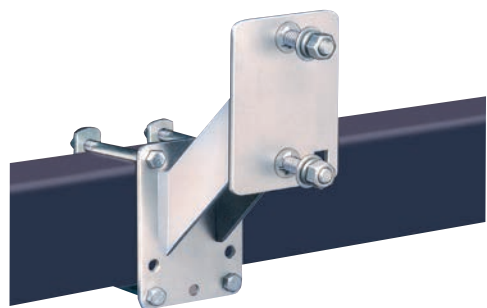

STC1000301

HI-MOUNT SPARE TIRE CARRIER

- Heavy-duty, welded and reinforced steel plate construction
- Zinc-plated to resist corrosion
- Adjustable bolt circle to fit both 4 and 5 lug wheels
- Fits all trailer tongues up to 3 in. wide by 4 in. high
- Includes zinc-plated mounting hardware and instructions
- Security locking hole to lock wheel and bracket to trailer using a security cable and lock (cable and lock sold separately)

Part Number	Description	Packaging	Master Carton
STC1000301	Hi-Mount Spare Tire Carrier	Bulk	1
STC1000101	Hi-Mount Spare Tire Carrier	Boxed	4



ETC 0101

ECONOMY SPARE TIRE CARRIER

- Fits 8, 9, 12, 13, 14 and 15 in. wheels with 4 or 5 lug rims
- Easy to install
- Includes lug nuts to secure wheel to frame
- Heavy duty 1/2 in. diameter construction
- Zinc plated to resist corrosion

Part Number	Description	Packaging	Master Carton
ETC 0101	Economy Spare Tire Carrier	Boxed	6
ETCLB 0700	Economy Spare Tire Carrier with Locking Levers	Boxed	6
ETCHL 0700	Economy Spare Tire Carrier with Locking Levers and HLO Lock	Boxed	6

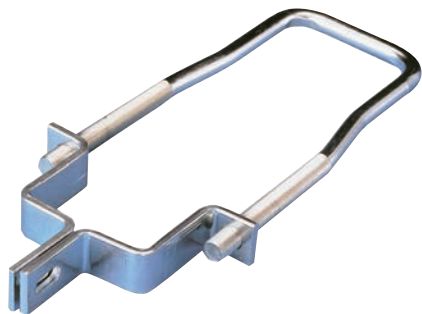

ETCLB 0700

ECONOMY SPARE TIRE CARRIER WITH LOCK

- Theft-resistant locking cap
- Fits over wheel studs up to 9/16 in. diameter to deter spare tire theft
- Removable plug allows longer wheel studs to protrude through cap
- Locking tab provides positive locking feature to prevent lock from turning

Part Number	Description	Packaging	Master Carton
ETCSTL0701	Economy Spare Tire Carrier with STL Spare Tire Lock	Boxed	6
STL 0603	Spare Tire Lock	Boxed	6



ETCSTL0701



PD110200



PD110700

POD HAZARD MULTI-USE LED ROADSIDE WARNING DEVICE

- Nine different illumination modes, including S.O.S safety mode to alert passing motorists
- Illuminate anything, anywhere with the 350 Lumens lamp and integrated red LED Warning lights
- Durable and weather resistant, easy grip plastic housing is compact (2 in. tall), easy to use and easy to store in the glove box
- Mounts to almost anything with its multiple mounting options including magnet, swivel hook, permanent base, or option for added hook and loop
- Use in the rain or snow
- Visible from 1/4 mile away in daylight conditions
- Use on a trailer, RV, vehicle or as an extra light source in a garage or workshop
- Requires 3 AAA Alkaline batteries per POD (not included)

Part Number	Description	Packaging	Master Carton
PD110200	POD HAZARD Multi-Use LED Roadside Warning Device, 2 Pack, Batteries Sold Separately	Litho Box	3
PD110700	POD HAZARD Counter Top Display, Includes (3) PD110200, Batteries Sold Separately	Counter Display	1
PD110101	POD HAZARD, 1 Pack, Batteries Sold Separately	Clamshell	6



7000100

WHEEL CHOCKS

- Made from high impact polymer
- Reduces the risk of trailer roll
- Fits most trailer wheels

Part Number	Description	Packaging	Master Carton
7000100	Wheel Chocks	Litho Box	6



63300

HITCH AND TRAILER ALIGNMENT TOOL

- Convenient one person hitch alignment system
- Magnetic base for fast and easy location
- Telescoping rods adjust up to 42 in.
- Easy to use the first time

Part Number	Description	Packaging	Master Carton
63300	Hitch and Trailer Alignment Tool	Clamshell	3

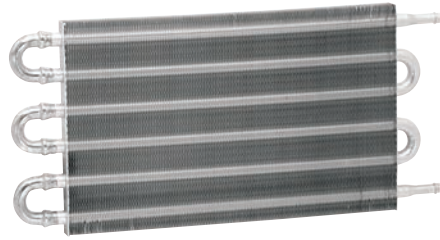

41013†

TUBE AND FIN TRANSMISSION COOLERS

LAST CHANCE

Part Number	Description	Substitute Part Number	Packaging	Master Carton
41011†	Full-Size Cars, Mini-Vans and SUVs Towing up to 2,500 lbs.	-	Litho Box	1
41013†	SUVs, Vans and Pickup Trucks Towing up to 5,000 lbs.	-	Litho Box	1
41014†	Pickup Trucks and Motorhomes Towing Over 5,000 lbs.	-	Litho Box	1



41310†

PLATE AND FIN TRANSMISSION COOLERS

LAST CHANCE

Part Number	Description	Substitute Part Number	Packaging	Master Carton
41019†	Compact to Mid-Size Cars Towing Under 2,000 lbs.	-	Litho Box	1
41020†	Full-Size Cars, Mini-Vans and SUVs Towing 2,000 - 3,500 lbs.	-	Litho Box	1
41310†	SUVs, Vans and Pickup Trucks Towing 3,500 - 5,000 lbs.	-	Litho Box	1
41311†	Pickup Trucks and Motorhomes Towing Over 5,000 lbs.	-	Litho Box	1
41312†	Pickup Trucks Towing Fifth Wheels and Gooseneck Trailers	-	Litho Box	1



3132†

TRANSMISSION COOLER ACCESSORIES

LAST CHANCE

Part Number	Description	Substitute Part Number	Packaging	Master Carton
3132†	Transmission Oil Cooler Hose, 1-1/32" I.D., 25' Long	-	Boxed	1
41103†	Metal Strap Mounting Kit	-	Litho Box	1
41405†	Nylon Tie Mount Kit (4 Per Bag)	-	Poly Bag	1



41412†



41410†

OEM CUSTOM FITTINGS

LAST CHANCE

Part Number	Description	Substitute Part Number	Packaging	Master Carton
41412†	1987 and Newer Jeep Adapter Kit for 5/8"-18, 45° S.A.E. Flare	-	Boxed	1
41410†	1983 and Newer Ford, Lincoln and Mercury Cars Adapter Kit for Duckbill Style Line Fittings	-	Boxed	1



1000750†

WATERWICK™

LAST CHANCE

Part Number	Description	Substitute Part Number	Packaging	Master Carton
1000750†	Waterwick	-	Litho Box	1

NOTE: Contains Calcium Chloride (salt). Possible adverse effects in case of contact with eyes.



SAFETY CHAINS

LAST CHANCE

Part Number	Description	Substitute Part Number	Packaging	Master Carton
49137†	Class I GVWR 2,000 Lbs. 48", 3/16" Proof Coil Grade 30, S-Hook, Both Ends	63034	Barrel	100
44140†	Class III GVWR 5,000 lbs. 48", 1/4" Proof Coil Grade 30, S-Hook, Both Ends	63035	Bulk	100
49148†	Class IV 32", 5/16" Proof Coil Grade 30 5/16" Clevis Slip Hook, One End (7,600 lbs. GTW)	CHA0040324	Bulk	100
49149†	Class IV 36", 1/2" Proof Coil Grade 30 3/8" Clevis Slip Hook, One End (10,600 lbs. GTW)	CHA0020324	Boxed	10
49147†	Class IV 35", 3/8" High Test 43 Clevis Slip and Latch Hook (16,200 lbs. GTW)	CHA0060324	Boxed	1
49138†	Class II GVWR 3,500 lbs. 24", 1/4" Proof Coil Grade 30, with S-Hook at One End	5592	Barrel	100
49141†	Class III GVWR 5,000 lbs. 30", 1/4" Proof Coil Grade 30, with S-Hook at One End	2489	Barrel	100



CLEVIS SLIP HOOKS

LAST CHANCE

Part Number	Description	Substitute Part Number	Packaging	Master Carton
44154†	Grade 43, Clevis Slip with Latch, 1/4"	44155	Bulk	10
44156†	Grade 43, Clevis Slip with Latch, 3/8"	44155	Bulk	10
44157†	Grade 43, Clevis Slip with Latch, 1/2"	44155	Bulk	10
44163†	Grade 70, Clevis Hook with Latch, 1/4"	44155	Bulk	10
44159†	Grade 70, Clevis Hook with Latch, 5/16"	44155	Bulk	10
44164†	Grade 70, Clevis Hook with Latch, 3/8"	44155	Bulk	10



TOW HOOKS

LAST CHANCE

Part Number	Description	Substitute Part Number	Packaging	Master Carton
63029†	Tow Hook with Mounting Bolts, Chrome, 10,000 lbs. Capacity	-	Poly Bag	6
63030†	Tow Hook with Mounting Bolts, Black, 10,000 lbs. Capacity	-	Poly Bag	6



QUICK LINKS

LAST CHANCE

Part Number	Description	Substitute Part Number	Packaging	Master Carton
49132†	1/4" Quick Link, 3,500 lbs. Capacity	74700	Bulk	200
49131†	5/16" Quick Link, 3,500 lbs. Capacity	74700	Bulk	200
44133†	3/8" Quick Link, 3,500 lbs. Capacity	74700	Bulk	200
49134†	7/16" Quick Link, 5,000 lbs. Capacity	74700	Bulk	200
49135†	1/2" Quick Link, 10,000 lbs. Capacity	74700	Bulk	200

† = Available while supplies last

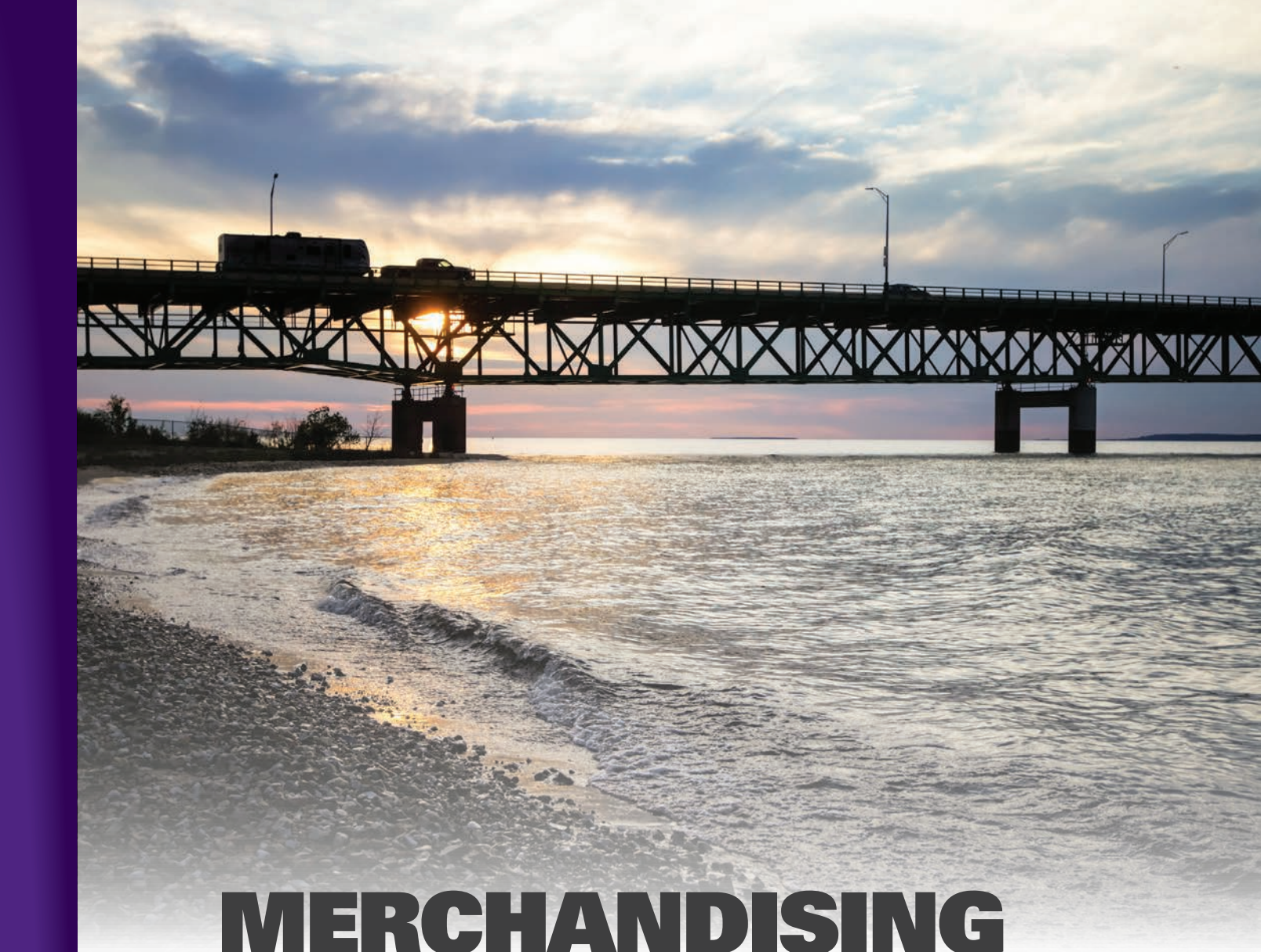

MERCHANDISING

Horizon Global provides a wide variety of product displays and marketing material that do a careful and well thought-out job of presenting our products and services: planograms, gondola displays, header cards, showroom signs, counter mats, banners, outdoor and indoor signs and window clings. All to help attract customers and increase sales.

PRODUCT DISPLAYS

Receiver Hitches.....	0-2
Weight Distribution Hitches	0-2
Fifth Wheel Hitches	0-3
Pin Boxes	0-3
RV Jacks.....	0-4
ZCI™ Counter Top Display.....	0-4
Velocity™ Series High-Speed Jacks.....	0-5
Electric Winches.....	0-5

MARKETING MATERIAL

Gondola Displays	0-6
Header Cards.....	0-6
Showroom Signs.....	0-7
Banners	0-7
Window Clings	0-7
Outdoor Signs	0-7



37-0030 - Display Stand Only



MKG0218

RECEIVER HITCH DISPLAY STAND

- Hitch display racks promote the products you install
- Turn your hitch display into an add-on sales tool by attaching the accessory display kit
- It is designed to help promote the sale of hitch balls, tow vehicle wiring, and other towing accessories
- Products must be ordered separately
- Casters not included
- See header cards and signs for additional hitch display graphics

Part Number	Description
37-0030	Draw-Tite 5 Hitch, 4 Ball Mount Display with Flip Chart Attachment
MKG0218	Draw-Tite Logo Sign, 41-1/2" x 10"
Suggested Receiver Hitches to Display	
24899	Sportframe Hitch, Class I
36423	Frame Hitch, Class II
75193	Max-Frame Hitch, Class III/IV
41946	Ultra Frame Hitch, Class V
45519	Heavy Duty 2-1/2" Hitch, Class V

NOTE: Casters may not be included with these displays, but will accept 3 in., 4 in., or 5 in. casters, with coarse thread 1/2 in. wide stem.

There may be charges for display items. Contact your sales representative for ordering information.



37-2109 - Display Stand Only

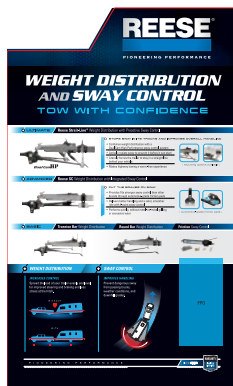

MKG1281

WEIGHT DISTRIBUTION HITCH DISPLAY STAND

- Weight distribution display stand promotes the products you install
- Stand will display one weight distribution hitch
- Products must be ordered separately
- Casters not included

Part Number	Description
37-2109	REESE Weight Distributing Stand, 2-5/16" coupler, 2" Receiver Tube Built-In, 2-5/16" Ball Not Included
MKG1281	REESE Weight Distribution Sway Control Display Signage for 37-2109, Includes Sign Attachment Brackets and Brochure Pocket
Suggested Weight Distribution Hitches to Display	
66542	1,200 lbs. High-Performance Trunnion Bar Weight Distribution Hitch
67509	800 lbs. Heavy Duty Round Bar Weight Distribution Hitch
26002	Dual Cam HP Sway Control
83660	Friction Sway Control
66082	Strait-Line 600 lbs. Trunnion Bar Weight Distribution Hitch
63835	Strait-Line 1,200 lbs. Round Bar Weight Distribution Hitch

NOTE: Casters may not be included with these displays, but will accept 3 in., 4 in., or 5 in. casters, with coarse thread 1/2 in. wide stem.

There may be charges for display items. Contact your sales representative for ordering information.



37-2103 - Display Stand Only



MKG0346

FIFTH WHEEL HITCH DISPLAY STAND

- Fifth wheel hitch display stand promotes the products you install
- Stand will display one fifth wheel hitch
- Width adjusts from 38 in. to 42 in. and includes signage posts
- Products must be ordered separately
- Rails and mounting brackets required for mounting hitch to display stand
- Casters not included

Part Number	Description
37-2103	REESE Heavy Duty Fifth Wheel Hitch Display with Bolt-On Signage Posts
MKG0346	REESE Logo Sign, 41-1/2" x 10"
MKG0255	REESE Elite Series Sign
Suggested Fifth Wheel Hitches to Display	
30929	M5 Series 27K Fifth Wheel Hitch
30142	Elite Series 18K Fifth Wheel Hitch
30144	Elite Series 18K Fifth Wheel Hitch with Slider
30081	20K Fifth Wheel Hitch
30871	Elite Series 26.5K Fifth Wheel Hitch
30126	Elite Series Fifth Wheel Rails, Ford
30035	Universal Fifth Wheel Rails
30153	Outboard Fifth Wheel Rails

NOTE: Casters may not be included with these displays, but will accept 3 in., 4 in., or 5 in. casters, with coarse thread 1/2 in. wide stem.

There may be charges for display items. Contact your sales representative for ordering information.



37-2130 - Shown with Sidewinder

PIN BOX DISPLAY STAND

- Pin box display stand promotes the products you install
- Stand will display one pin box
- REESE® 16K fifth wheel hitch head, signage and brochures are included with display stand
- Products must be ordered separately
- Casters not included

Part Number	Description
37-2130	REESE Pin Box Display Stand
Suggested Pin Boxes to Display	
61420	16K Sidewinder Pin Box
5AB-E1621-16K	16K 5th Airborne Pin Box
61422	16K Elite Series 5th Airborne/Sidewinder Combo Pin Box

NOTE: Casters may not be included with these displays, but will accept 3 in., 4 in., or 5 in. casters, with coarse thread 1/2 in. wide stem.

There may be charges for display items. Contact your sales representative for ordering information.



600051 - Display Stand Only



600051 - Display Stand Only



MKG0358 - Display Only

RV JACK DISPLAY STANDS

- Display stands increase end-user visibility to A-Frame Jacks
- Using a minimal amount of floor space these stands provide easy access to customers
- Products must be ordered separately
- Casters not included

Part Number	Description
600051	Jack Display Stand, Includes: (1) Integrated Center A-Frame Mount and (4) A-Frame Jack Display Adapters
37-2126	RV Jack Display Stand, Includes (4) Jack Display Adapters #117400
37-2134	A-Frame Jack Mount System for Lozier Gondola, Includes: (1) 37-2131 Crossbar, (5) 37-2132 Brackets and (1) 37-2133 Bracket Support
117398	Jack Display Stand Only
117400	RV Jack Display End Caps, Jack Adapter Only
Suggested Jacks to Display	
1551570117	2K BULLDOG A-Frame Jack, Sidewind
1550220117	2K BULLDOG A-Frame Jack, Topwind
1550320117	5K BULLDOG A-Frame Jack, Topwind
1750290317	5K BULLDOG A-Frame Jack, Topwind
EA20000103	2K Pro Series A-Frame Jack, Topwind
RV20000103	2K Pro Series A-Frame Jack, Sidewind
1400600303	5K Pro Series A-Frame Jack, Topwind
EA20000340	2K Pro Series A-Frame Jack, Topwind
500199	4K BULLDOG A-Frame Jack with Powered Drive, Black
500200	4K BULLDOG A-Frame Jack with Powered Drive, White
500187	3.5K BULLDOG A-Frame Jack with Powered Drive, Black
500188	3.5K BULLDOG A-Frame Jack with Powered Drive, Black
500198	2.5K Pro Series A-Frame Jack with Powered Drive, Black

NOTE: Casters may not be included with these displays, but will accept 3 in., 4in., or 5 in. casters, with coarse thread 1/2 in. wide stem.

There may be charges for display items. Contact your sales representative for ordering information.

ZCI™ COUNTER TOP DISPLAY

- Counter top display with interchangeable insert cards
- Cards are easily removed to change display as often as needed
- Insert cards and brochures sold separately

Part Number	Description
MKG0358	Tekonsha ZCI Counter Top Display
MKG2136	Tekonsha ZCI Counter Top Display Brochures

There may be charges for display items. Contact your sales representative for ordering information.



VELOCITY SERIES™ HIGH-SPEED JACK DISPLAY STAND

- Display stand increases end-user visibility to Velocity Series™ High-Speed Jacks
- Using a minimal amount of floor space these stands provide easy access to customers
- Stand will display one jack
- Products must be ordered separately
- Casters not included

Part Number	Description
37-0023	BULLDOG Velocity Series High-Speed Jack Display Stand
MKG2097	BULLDOG Velocity Series High-Speed Jack Display Signage
Suggested Jack to Display	
185400	BULLDOG Velocity Series High-Speed Jack, with Remote
185402	BULLDOG Velocity Series High-Speed Jack

NOTE: Casters may not be included with these displays, but will accept 3 in., 4in., or 5 in. casters, with coarse thread 1/2 in. wide stem.

There may be charges for display items. Contact your sales representative for ordering information.



ELECTRIC WINCH DISPLAY STAND

- Display stand increases end-user visibility to electric winches
- Using a minimal amount of floor space these stands provide easy access to customers
- Stand will display three electric winches
- Products must be ordered separately
- Casters not included

Part Number	Description
37-3016	BULLDOG Electric Winch Display Stand
37-2075	BULLDOG Electric Winch Aluminum Sign
Suggested Winches to Display	
500630	2,500 lbs. BULLDOG ATV Winch
500402	4,500 lbs. BULLDOG Utility Winch
500426	9,000 lbs. BULLDOG Heavy Duty Winch

NOTE: Casters may not be included with these displays, but will accept 3 in., 4in., or 5 in. casters, with coarse thread 1/2 in. wide stem.

There may be charges for display items. Contact your sales representative for ordering information.

GONDOLA DISPLAY RACKS

- Gondola display accessories offer your customers a complete line of towing and vehicle accessories
- Products must be ordered separately

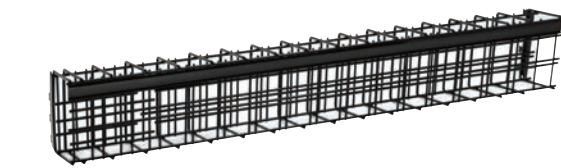

37-2112



37-2114



37-2127

Part Number	Description
37-2112	4' Ball Mount Rack for Lozier Gondola
37-2114	4' Hitch Ball Rack for Lozier Gondola
37-2127	4' Hitch Ball and Ball Mount Rack for Lozier Gondola, Half and Half
37-2131	4' Crossbar for Lozier Gondola, Mount up to 5 Brackets, 37-2132
37-2132	Trailer Jack A-Frame Mount Bracket for Lozier Gondola
37-2133	Trailer Jack A-Frame Mount Bracket Support for Lozier Gondola
37-2134	Trailer Jack A-Frame Mount System for Lozier Gondola, Includes: (1) 37-2131 Crossbar, (5) 37-2132 Brackets and (1) 37-2133 Bracket Support

There may be charges for display items. Contact your sales representative for ordering information.



MKG0209



MKG0218



MKG0346

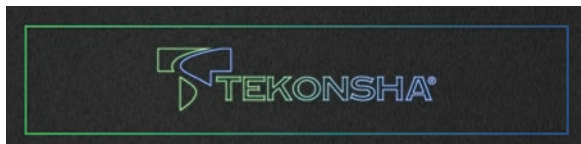

MKG0188



MKG3253

HEADER CARDS AND SIGNS

- Merchandising headers in a wide range of sizes for use on displays or any showroom application

Part Number	Description
MKG0209	BULLDOG The Choice of America's Military & Manufacturers Merchandising Sign, 14" x 48"
MKG0218	Draw-Tite Logo Merchandising Sign, 10" x 41-1/2"
MKG0219	Draw-Tite Merchandising Sign, 14" x 42"
MKG0182	REESE Pioneering Performance Merchandising Sign, 15" x 39"
MKG0205	REESE Merchandising Sign, 14" x 42"
MKG0255	REESE Elite Series Fifth Wheel Hitches Merchandising Sign, 20" x 41-1/2"
MKG0346	REESE Logo Merchandising Sign, 10" x 41-1/2"
MKG0466	REESE Titan Series Fifth Wheel Hitches Merchandising Sign, 20" x 41-1/2"
MKG0188	Tekonsha Logo Merchandising Sign, 6" x 24"
MKG3253	Fulton Merchandising Sign, 12" x 48"

There may be charges for display items. Contact your sales representative for ordering information.



MKG0202



MKG1276



MKG0198



37-5652

BANNERS

- Attract customers with branded, durable, indoor and outdoor banners

Part Number	Description
MKG0196	Draw-Tite Tested Tough, 5' x 3' with four grommets
MKG0202	REESE Products, 5' x 3' with four grommets
MKG1276	BULLDOG, The Choice of America's Military & Manufacturers, 5' x 3'
MKG2090	REESE We Sell, Secure Your Passion Banner, with four grommets, French, 6' x 3'

There may be charges for display items. Contact your sales representative for ordering information.

HOURS OF OPERATION SIGNS

Part Number	Description
MKG0198	REESE Hours of Operation Indoor Sign
MKG2806	REESE Hours of Operation Indoor Sign, French
MKG0216	Draw-Tite Hours of Operation Indoor Sign

There may be charges for display items. Contact your sales representative for ordering information.

WINDOW CLING

Part Number	Description
MKG1929	Draw-Tite Hide-A-Goose Hitch, 4" x 6", Two Sided

There may be charges for display items. Contact your sales representative for ordering information.



TECHNICAL

All products are covered by warranty for a minimum of one (1) year. Some products have longer warranty coverage periods.

If you have questions regarding product performance, safety related issues or installation instructions, please do not hesitate to contact our technical service group.

ELECTRICAL WIRING

Trailer Wiring	P-2
4-Way Flat	P-2
5-Way Flat	P-2
4-Way Round Pin	P-3
6-Way Round Pin	P-3
7-Way RV Blade	P-3
7-Way Pin Clocking	P-4
Agricultural 7-Way Round Pin	P-4

BRAKE CONTROLS

Wiring Instructions	P-5
Wiring Harness Chart	P-7 - P-8
Brake Control Reference Guide	P-9
Trailer Emulator Reference Guide	P-10

TRAILER BRAKES

Breakaway Switch Instructions	P-10
Battery and Charger Instructions	P-11
Trailer Brake Troubleshooting	P-12
Trailer Brake Adjustment	P-12
Trailer Brake Part Identification	P-13

ELECTRICAL TESTERS

Bench Tester Instructions	P-14
Current Monitor Instructions	P-14
Trailer Tester Instructions	P-15

TRAILER LIGHTING

Agricultural Lighting Diagrams	P-16 - P-18
Federal Lighting Requirements	P-19 - P-22

JACKS

Weld-On Mounting Positions	P-23
Swivel Mount Height Adjustment	P-24
Replacement Quick Reference Guide	P-25
Whole Jack Examples	P-26
Assembly Quick Reference Guide	P-27

WINCHES

Electric Winch Data and Dimensions	P-28 - P-31
Hydraulic Winch Data and Dimensions	P-32

HOISTS

Electric Hoist Data and Dimensions	P-33 - P-34
--	-------------

WIRING DIAGRAM FOR TYPICAL 4-FLAT WISHBONE CONNECTOR

- 5-Way connector would include blue wire for auxiliary

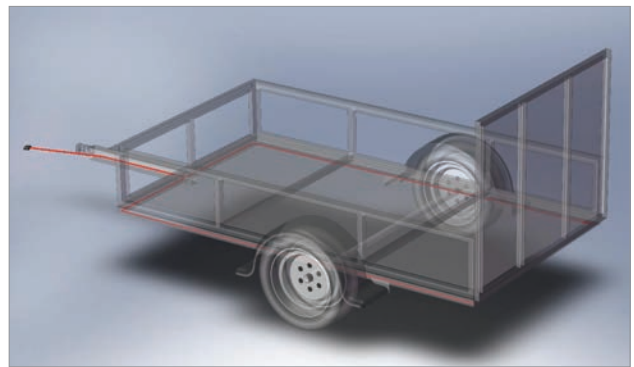
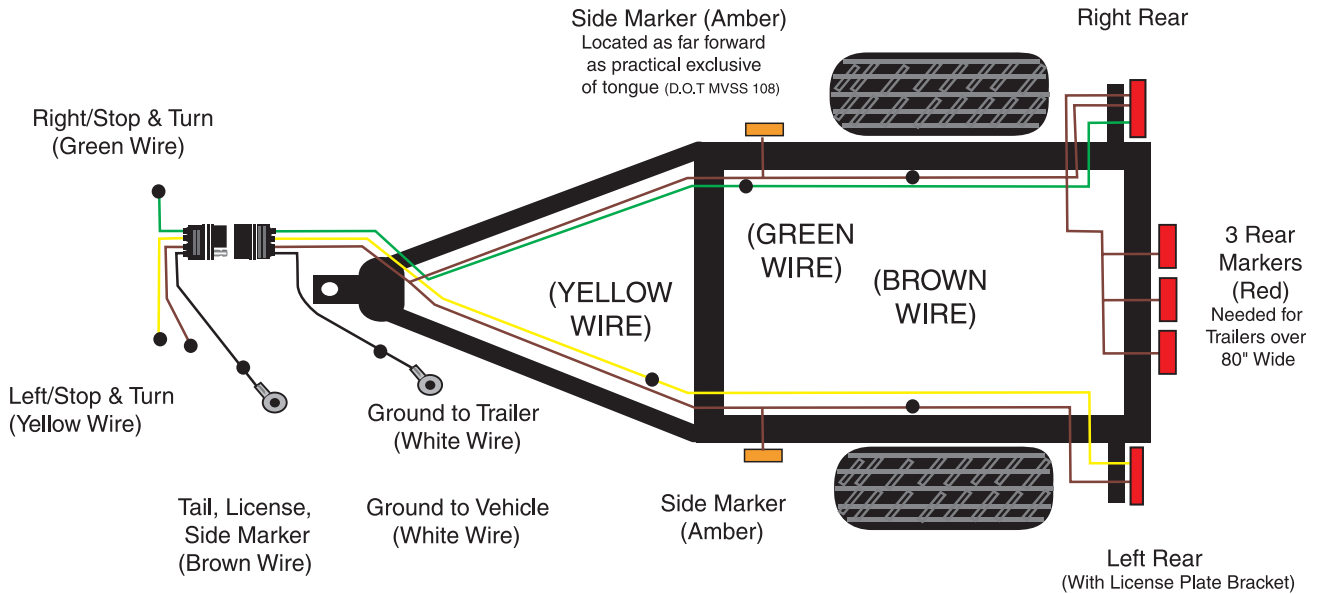

4-WAY FLAT CONNECTOR

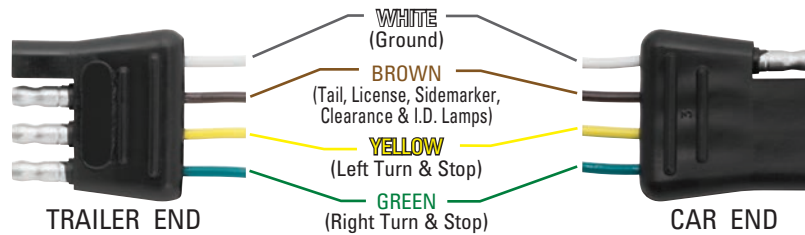

5-WAY FLAT CONNECTOR

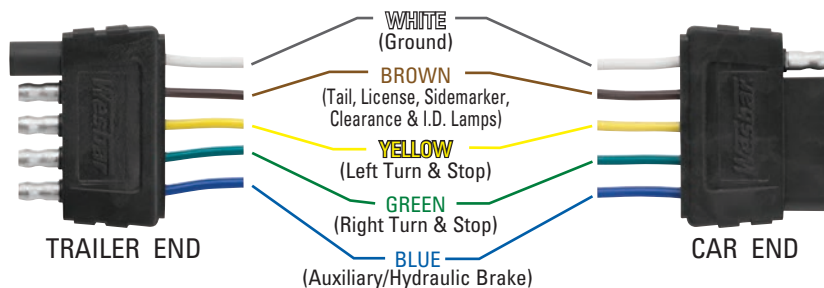

4-WAY ROUND PIN CONNECTOR

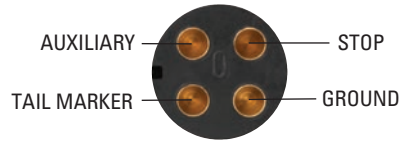

TRAILER END
As viewed from core back side where wires are attached with screws.

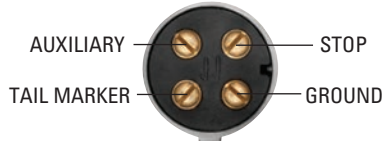

CAR END
As viewed from core back side where wires are attached with screws.

6-WAY ROUND PIN CONNECTOR

Molded Connector

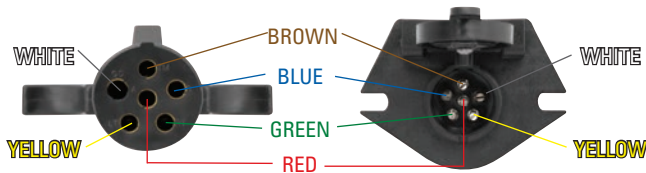

TRAILER END
As viewed from front face of 6-Way connector with molded on cable.

CAR END
As viewed from front face of 6-Way connector with sealed cable.

Die-Cast Connector

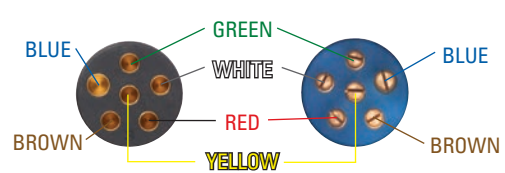

TRAILER END
As viewed from core back side where wires are attached with screws.

CAR END
As viewed from core back side where wires are attached with screws.

6-WAY WIRING INDEX

Wire Color	Gauge	Molded Connector Terminal	Die-Cast Connector Terminal
White	10/14	Common Ground	GD - Common Ground
Blue	10/14	Electric Brake	S - Electric Brake
Green	14	Right Stop and Turn	TM - Tail and License
Red	10/14	Auxiliary	LT - Left Stop and Turn
Brown	14	Tail and License	RT - Right Stop and Turn
Yellow	14	Left Stop and Turn	A - Auxiliary

7-WAY RV BLADE CONNECTOR

Molded Connector

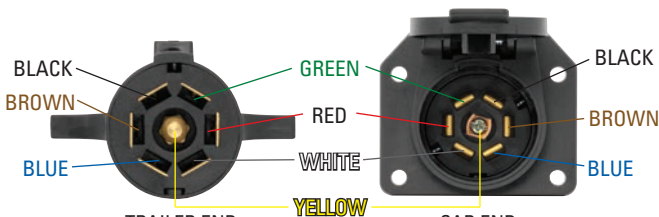

TRAILER END
As viewed from front face of 7-Way connector with molded on cable.

CAR END
As viewed from front face of 7-Way connector with sealed cable.

Plastic/Metal Connector

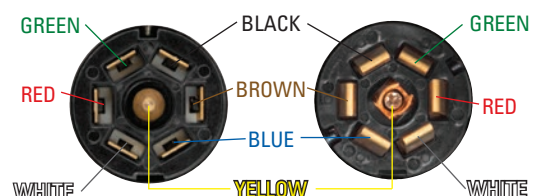

TRAILER END
As viewed from core back side where wires are attached with screws.

CAR END
As viewed from core back side where wires are attached with screws.

7-WAY RV BLADE WIRING INDEX

Wire Color	Gauge	Molded Connector Terminal	Plastic/Metal Connector Terminal
White	10	Common Ground	#1 - Common Ground
Blue	12	Electric Brake	#2 - Electric Brake
Green	14	Tail and License	#3 - Tail and License
Black	10	Battery Charge	#4 - Battery Charge
Red	14	Left Stop and Turn	#5 - Left Turn and Stop
Brown	14	Right Stop and Turn	#6 - Right Turn and Stop
Yellow	14	Center Auxiliary	#7 - Center Auxiliary

7-WAY PIN CLOCKING CONNECTORS

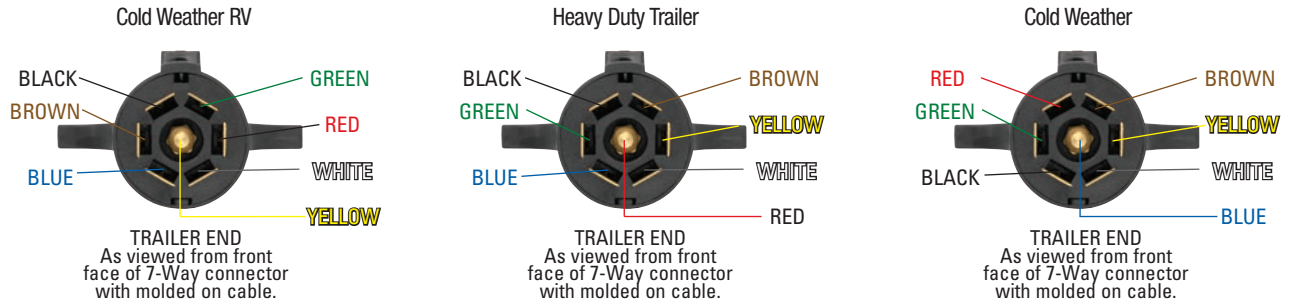

7-WAY PIN CLOCKING WIRING INDEX

Wire Color	Cold Weather RV Function and Gauge	Heavy Duty Trailer Function and Gauge	Cold Weather Function and Gauge
White	Common Ground / 10	Common Ground / 10	Common Ground / 10
Blue	Electric Brake / 12	Electric Brake / 12	Electric Brake / 14
Green	Tail and License / 14	Tail and License / 14	Tail and License / 14
Black	Battery Charge / 10	Battery Charge / 10	Battery Charge / 10
Red	Left Stop and Turn / 14	Left Stop and Turn / 14	Left Stop and Turn / 10
Brown	Right Stop and Turn / 14	Right Stop and Turn / 14	Right Stop and Turn / 14
Yellow	Center Auxiliary / 14	Center Auxiliary / 14	Center Auxiliary / 14

NOTE: 7-Way Heavy Duty and Cold Weather trailer wiring diagrams represent wire location and color but are NOT supplied to represent any wire or color functions. Please contact your trailer manufacturer for further details.

AG 7-WAY ROUND PIN CONNECTOR

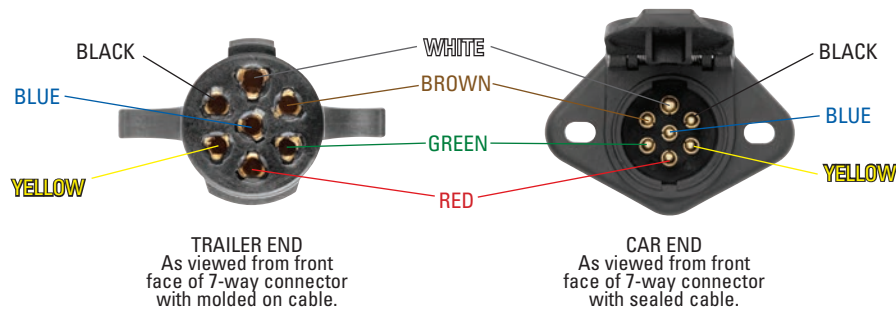

AG 7-WAY WIRING INDEX

Wire Color	Molded Connector Terminal	Plastic/Metal Connector Terminal
White	Common Ground	Common Ground
Black	Works Lamps	Works Lamps
Yellow	Left Hand Flashing and Turn Indicators	Left Hand Flashing and Turn Indicators
Red	Short Lamps	Short Lamps
Green	Right Hand Flashing and Turn Indicators	Right Hand Flashing and Turn Indicators
Brown	Tail Lamps	Tail Lamps
Blue	Switched Power (12V)	Switched Power (12V)

Technical information is current as of the printing of this catalog. Contact technical service for periodic updates.

WIRE INSTRUCTIONS FOR ELECTRONIC BRAKE CONTROLS

Generic Wiring Diagram

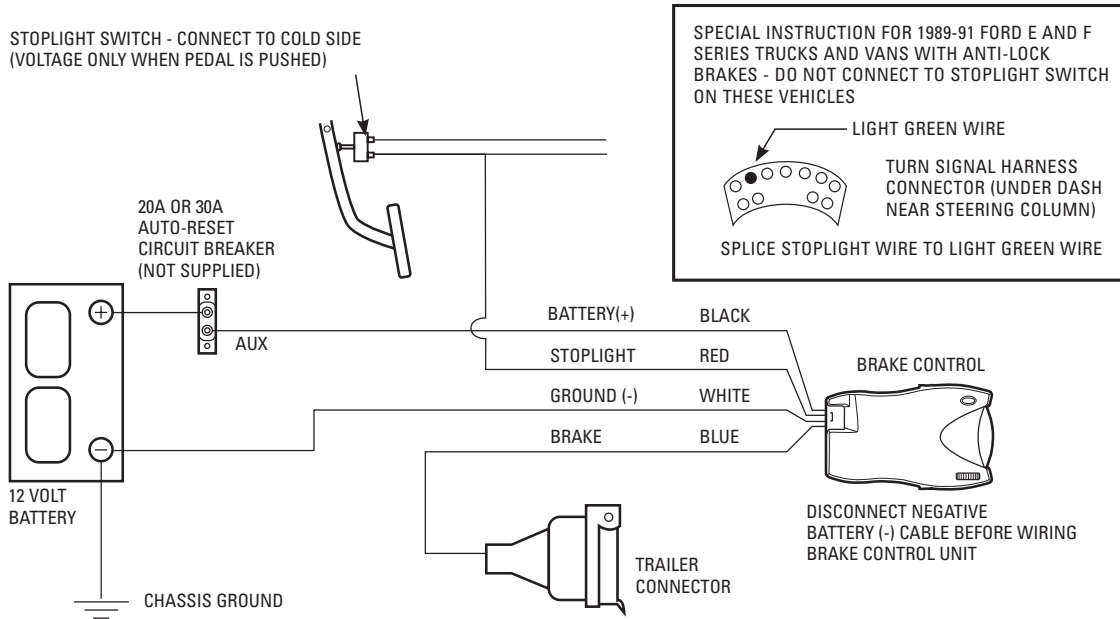

READ THIS FIRST:

Read and follow all instructions carefully before wiring brake control. Keep these instructions with the brake control for future reference.

Important Facts to Remember

1. The brake control must be installed with a 12 volt negative ground system. (To install with a positive ground system use Tekonsha® P/N 3191.)
2. **⚠ WARNING** Reversing BLACK and WHITE wires or improper wiring will damage or destroy brake control.
3. **⚠ WARNING** Be sure to solidly connect all four wires or brake control will not function properly.
4. Soldering is recommended or crimp-on butt connectors are a suitable substitution.
5. Route all wires as far from the radio antenna as possible to reduce AM interference.

6. **⚠ CAUTION** Use of proper gauge wire when installing the brake control is CRITICAL; smaller gauge wire may result in less than efficient braking. Minimum wire gauges are as follows:
 - 1-2 axle applications – 14 GA.
 - 3-4 axle applications – 12 GA.
7. Collection of water inside the trailer connector mounted on the tow vehicle will reduce the life of the connector.

1. The WHITE (-) wire must be connected to a known ground.
2. **⚠ CAUTION** Inadequate grounding may cause intermittent braking or lack of sufficient voltage to trailer brakes. The WHITE wire must be connected to a suitable ground location. The negative terminal of the battery is a suitable ground location in the absence of a Trailer Tow Package connection.
3. Connect BLACK (+) wire through an automatic reset circuit breaker (20 amp for 1-2 axles, 30 amp for 3-4 axles) to the POSITIVE (+) terminal of the battery. The BLACK wire is the power supply line to the brake control.
4. The RED (stoplight) wire must be connected to the cold side of the brake pedal stoplight switch. Splice down line from the switch; DO NOT disturb the position of the switch.
5. The BLUE (brake output) wire must be connected to the trailer connector's brake wire.

Wiring Legend

BLACK Wire (Positive Battery)

WHITE Wire (Negative Battery)

RED Wire (cold side of stoplight switch)

BLUE Wire (brake output to trailer)

BRAKE CONTROL WIRING HARNESS CHART

⚠ WARNING When using a wiring harness supplied by your vehicle's Manufacturer (OE Harness), DO NOT MATCH COLORS. Please follow wiring chart below.

OE HARNESS	BRAKE CONTROL WIRE	FUNCTION
CHEVROLET		
RED	BLACK	12 VOLT
LIGHT BLUE	RED	STOPLIGHT
BLACK	WHITE	GROUND
DARK BLUE	BLUE	TRAILER BRAKES
BROWN	N/A	ILLUMINATION
GM 2007 AND NEWER (NEW BODY STYLE)		
RED / BLACK TRACER	BLACK	12 VOLT
LIGHT BLUE / WHITE TRACER	RED	STOPLIGHT
WHITE	WHITE	GROUND
DARK BLUE	BLUE	TRAILER BRAKES
ORANGE	N/A	STOPLIGHT
DODGE (GREEN WIRE)		
WHITE W/ RED TRACER	BLACK	12 VOLT
BLUE W/ WHITE TRACER	RED	STOPLIGHT
GREEN W/ BLACK TRACER	WHITE	GROUND
BLUE	BLUE	TRAILER BRAKES
DODGE		
RED W/ BLACK TRACER	BLACK	12 VOLT
WHITE W/ TAN TRACER	RED	STOPLIGHT
BLACK	WHITE	GROUND
BLUE	BLUE	TRAILER BRAKES
2010 & NEWER DODGE		
YELLOW W/ GREEN TRACER	BLACK	12 VOLT
WHITE	RED	STOPLIGHT
BLACK W/ GREEN TRACER	WHITE	GROUND
GREEN	BLUE	TRAILER BRAKES
2010 & NEWER DODGE		
YELLOW W/ RED TRACER	BLACK	12 VOLT
WHITE	RED	STOPLIGHT
BLACK W/ GREEN TRACER	WHITE	GROUND
GREEN	BLUE	TRAILER BRAKES
FORD (PINK WIRE)		
PINK	BLACK	12 VOLT
RED	RED	STOPLIGHT
WHITE	WHITE	GROUND
BLUE	BLUE	TRAILER BRAKES
BROWN	N/A	ILLUMINATION
FORD		
RED	BLACK	12 VOLT
LIGHT GREEN	RED	STOPLIGHT
WHITE	WHITE	GROUND
DARK BLUE	BLUE	TRAILER BRAKES
BROWN	N/A	ILLUMINATION
FORD (PURPLE WIRE)		
RED	BLACK	12 VOLT
PURPLE W/ WHITE TRACER	RED	STOPLIGHT
BLACK W/ WHITE TRACER	WHITE	GROUND
BLUE	BLUE	TRAILER BRAKES
BROWN	N/A	ILLUMINATION
FORD 2008 SUPER DUTY		
RED	BLACK	12 VOLT
YELLOW W/ GREEN TRACER	RED	STOPLIGHT
BLACK W/ GRAY TRACER	WHITE	GROUND
BLUE	BLUE	TRAILER BRAKES

BRAKE CONTROL WIRING HARNESS CHART

⚠ WARNING When using a wiring harness supplied by your vehicle's Manufacturer (OE Harness), DO NOT MATCH COLORS. Please follow wiring chart below.

OE HARNESS	BRAKE CONTROL WIRE	FUNCTION
FORD		
RED	BLACK	12 VOLT
GREEN	RED	STOPLIGHT
WHITE	WHITE	GROUND
BLUE	BLUE	TRAILER BRAKES
FORD		
BROWN W/ RED TRACER	BLACK	12 VOLT
BLUE W/ ORANGE TRACER	RED	STOPLIGHT
GRAY W/ BLACK TRACER	WHITE	GROUND
BLUE	BLUE	TRAILER BRAKES
TOYOTA		
BLACK W/ RED TRACER	BLACK	12 VOLT
GREEN	N/A	ILLUMINATION
GREEN W/ WHITE TRACER	RED	STOPLIGHT
BROWN	WHITE	GROUND
RED	BLUE	TRAILER BRAKES
TOYOTA / LEXUS		
BLACK	BLACK	12 VOLT
GREEN W/ YELLOW TRACER	RED	STOPLIGHT
WHITE W/ BLACK TRACER	WHITE	GROUND
YELLOW	BLUE	TRAILER BRAKES
GREEN	N/A	ILLUMINATION
NISSAN / INFINITY		
RED	BLACK	12 VOLT
RED W/ GREEN TRACER	RED	STOPLIGHT
BLACK	WHITE	GROUND
BROWN W/ WHITE TRACER	BLUE	TRAILER BRAKES
RED W/ BLUE TRACER	N/A	ILLUMINATION
VOLKSWAGEN / PORSCHE		
CAVITY #2 (RED W/ YELLOW TRACER)	BLACK	12 VOLT
CAVITY #3 (BLACK W/ RED TRACER)	RED	STOPLIGHT
CAVITY #1 (BROWN)	WHITE	GROUND
CAVITY #4 (BLUE)	BLUE	TRAILER BRAKES
HONDA		
BLUE	BLACK	12 VOLT
WHITE W/ BLACK TRACER	RED	STOPLIGHT
BLACK	WHITE	GROUND
BROWN W/ WHITE TRACER	BLUE	TRAILER BRAKES
BLUE	BLACK	12 VOLT
LIGHT BLUE	RED	STOPLIGHT
BLACK	WHITE	GROUND
BROWN W/ WHITE TRACER	BLUE	TRAILER BRAKES
FREIGHTLINER		
RED	BLACK	12 VOLT
SMALL RED W/ WHITE TRACER	RED	STOPLIGHT
BLACK	WHITE	GROUND
LARGE RED W/ WHITE TRACER	BLUE	TRAILER BRAKES
BROWN	N/A	ILLUMINATION
ACADIA / ENCLAVE / OUTLOOK		
RED W/ BLACK TRACER	BLACK	12 VOLT
WHITE	RED	STOPLIGHT
BLACK	WHITE	GROUND
BLUE	BLUE	TRAILER BRAKES
GREY	N/A	ILLUMINATION

BRAKE CONTROLS WITH LCD DISPLAY

90195 – P3®

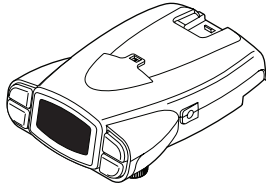

Brake Control's display should show:



- With trailer emulator connected and no manual slide activation.
- Varying voltage displayed from 0-13 as manual is activated with the power knob full on.

BRAKE CONTROLS WITH DIGITAL DISPLAY

90250 – Prodigy RF®

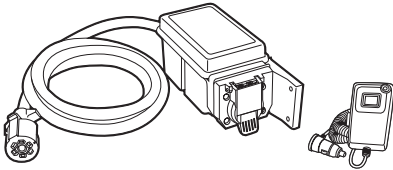

90185 – Prodigy® / 90885 – Prodigy® P2

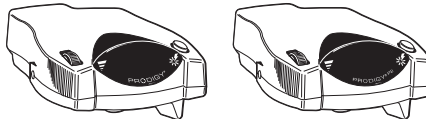

90160 – Primus™ IQ

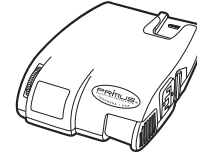

5535 – I-Command™

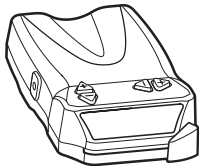

80550 – Pilot®



Brake Control's display should show:

- .c - With trailer emulator connected and no manual slide activation ("c" indicates connection to the trailer).
- Varying voltage displayed from 0-13 as manual is activated with the power knob full on.

BRAKE CONTROLS WITH LED DISPLAY

9030 – Voyager®

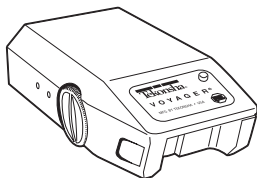

80500 – POD™

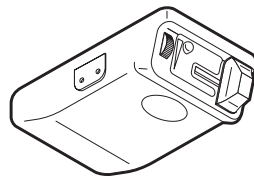

Brake Control's display should show:

- GREEN - with trailer emulator connected with no manual slide activation.
- GREEN to varying colors of RED - trailer emulator connected and manual slide activated.

Technical information is current as of the printing of this catalog. Contact technical service for periodic updates.

TRAILER EMULATOR REFERENCE GUIDE

User's Guide

The Trailer Emulator requires the ground and 12 volt battery line to be properly connected in order to check the electric brake circuit.

- 12 volt light on the emulator will be lit as soon as the emulator is connected to the tow vehicle's plug. If this does not happen see Troubleshooting Chart.
- The RT, LT, TL and BU lights will light on the emulator as those functions are activated on the tow vehicle. If this does not happen see Troubleshooting Chart.
- The BK light on the emulator should be off until the brake control is activated. (May see a flicker but not on steady) NOTE: The trailer emulator is not an exact trailer load so the light displays on various brake controls will respond differently.

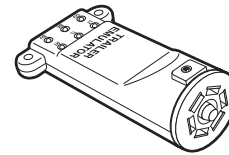

- LT – Left turn signal, Red Light
- TL – Tail / running lights, Red Light
- RT – Right turn signal, Red Light
- 12V – 12 volt battery supply line, Red Light
- BK – Electric trailer brakes, Red Light
- BU – Backup lights, Red Light

Troubleshooting Chart

Condition	Probable Cause
Trailer Emulator connected to tow vehicle:	
- 12V LED is NOT lit on Trailer Emulator.	1) Bad ground or incorrect wiring in tow vehicle connector. 2) No 12 volt battery power supplied to connector.
- LT LED is NOT lit on Trailer Emulator NOTE: Applies for LT, RT, TL and BU LEDs.	1) Bad ground or incorrect wiring in tow vehicle connector. 2) Loose or poor connection in circuit under test.
- BK is NOT lit on Trailer Emulator when <u>manual slide / touch pad</u> is activated, but 12V LED is lit.	1) Bad ground or incorrect wiring in tow vehicle connector. 2) Poor ground on Brake Control. Brake Control goes into a limit mode. 3) Gain adjustment on Brake Control is set to minimum, adjust gain to maximum and retest using manual.
- BK is NOT lit on Trailer Emulator when <u>Brake Pedal</u> is depressed, but 12V LED is lit.	1) If using brake pedal, Tekonsha's inertia activated controls require vehicle movement to activate sensor. Apply the manual switch and see if BK LED lights. (SEE NOTE)

Note: The following two methods are available to test the Automatic response of the Tekonsha brake control with the Trailer Emulator.

1. Vehicle in Motion Method
 - Connect Trailer Emulator to vehicle.
 - Properly adjust the Level of the brake control.
 - Drive vehicle and apply brake pedal, the brake control's light should indicate a braking event.
2. Aggressive Level Method
 - Connect Trailer Emulator to vehicle.
 - Properly adjust the Level of the brake control.
 - Adjust Level setting toward Aggressive.
 - The brake control's light should indicate a braking event.
 - When finished with test remember to adjust the brake control's level back to desired tow setting.

BREAKAWAY SWITCH INSTALLATION INSTRUCTIONS

READ THIS FIRST:

Read and follow all instructions carefully before installing or operating the breakaway Switch. Keep these instructions for future reference.

Important Facts to Remember

1. ATTENTION INSTALLER: Please give this sheet to consumer upon completion of installation.
2. SAFETY ITEM: Solder all wire connections.
3. Check condition of battery prior to each trip.
4. **WARNING** Disconnect trailer plug before testing breakaway unit. Failure to do so will result in severe damage to electronic brake control.
5. **WARNING** Check your breakaway system periodically to insure that wiring and connections are secure. A short or an open circuit can result in a no-brake condition.
6. For optimal performance, it is recommended that breakaway devices be replaced every 3-5 years.

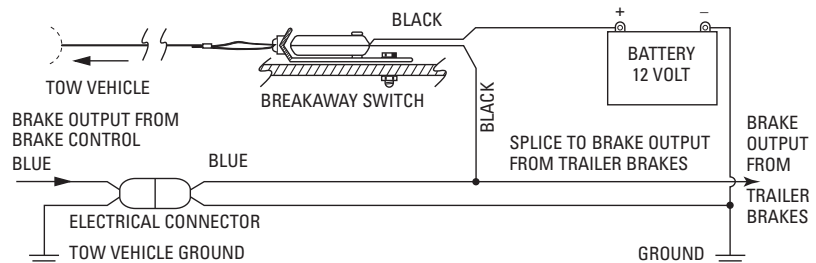

Installation Guide

1. Mount Battery Case securely to frame, jack post or other suitable location on trailer with Breakaway Switch Cable towards tow vehicle.
2. **WARNING** Switch location should be selected to ensure unobstructed line of pull in event of vehicle separation.
3. Bolt breakaway switch bracket to frame of trailer or battery case bracket using 1/4" bolt and lock nut or (2) 1/4" jam nuts. (Bolt and nuts not included in kit.)
4. **WARNING** Do not over tighten bolt. Switch must be able to pivot.
5. Disconnect trailer from tow vehicle. Check and install battery.
6. Wire per schematic. Properly insulate all connections.
7. Attaching to tow vehicle: Attach Breakaway Switch Cable to tow vehicle frame being certain the cable does not drag on the ground and no strain or restriction is placed on the cable.
8. **WARNING** Do not hook cable to safety chain loop or hitch ball.

ABCD / TOW CHARGER / 12 VOLT LEAD-ACID BATTERY INSTRUCTIONS AND INSTALLATION

READ THIS FIRST:

Check condition of battery prior to installation and prior to each trip.

1. Remove Charger and Battery from the battery case.
2. Mount battery case securely to frame, jack post or other suitable location on trailer.
3. Bolt Breakaway Switch\ to frame of trailer or battery case bracket.
4. Disconnect trailer from tow vehicle. Install battery and charger into the battery case. Feed wires out the back, then close the top.
5. Wire per schematic diagram. Properly insulate all connections.

6. Provide adequate air circulation when charging battery. Do not charge battery in any other container besides the supplied battery box.
7. **CAUTION** Do not place batteries in close proximity to objects which can produce sparks or flames.
8. Do not expose battery case to organic solvents or adhesives.
9. **CAUTION** Do not attempt to disassemble batteries. Contact with sulfuric acid may cause harm.
10. **CAUTION** Fasten batteries tightly and make provisions for shock absorption if exposure to shock or vibration is likely.
11. **WARNING** Do not throw batteries into fire; batteries so disposed may rupture or explode.

Battery Data Chart

- 12 VOLT
- Maximum charge current must be limited to 1.2 amps
- Length = 3.54" Width = 2.76" Height = 4.13"
- Terminals: Fasten Tab .187" x .032"
- Service Life:
Under normal operating conditions, 4-5 years in standby applications or 200-1000 charge/discharge cycles depending upon depth of discharge and rate of charge.

Important Facts to Remember

1. **CAUTION** Improper installation of the breakaway battery will destroy the brake control. The negative (-) terminal must attach to ground and positive (+) terminal must attach to the breakaway switch.
2. **WARNING** Check your Breakaway System\ periodically to insure that wiring and connections are secure. A short or an open circuit can result in a no-brake condition.
3. If excessive discharging of the breakaway battery occurs, check battery and recharge using a Heavy Duty Multi Stage/Maintenance Charger. Tekonsha charger 2024-07 is recommended for proper charging.
4. If the secondary battery needs charging, current will be drawn from the tow vehicle's battery at anytime the tow vehicle is connected to the trailer. Tekonsha charger 2024-07 is recommended for proper charging.
5. To only charge the breakaway battery when vehicle is running, a battery isolator may be installed in the 12 volt supply line (RED wire for tow charger).

HEAVY DUTY QUICK/MAINTENANCE MULTI STAGE CHARGER

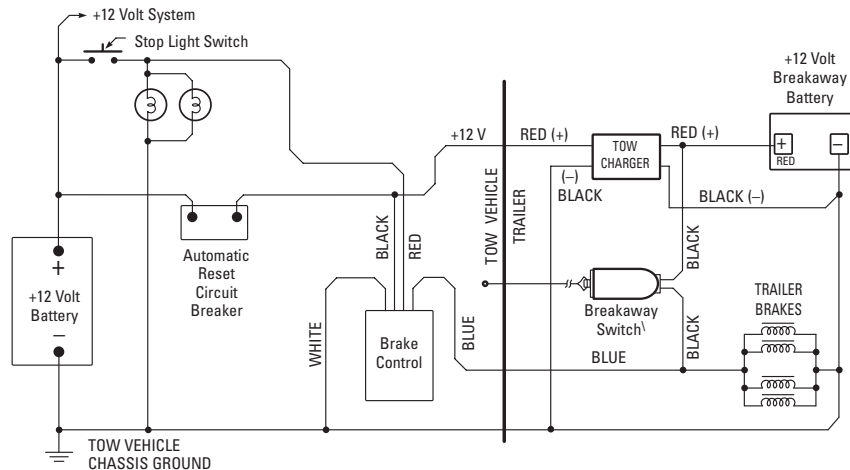

ABCD (Accelerated Battery Charging Device)

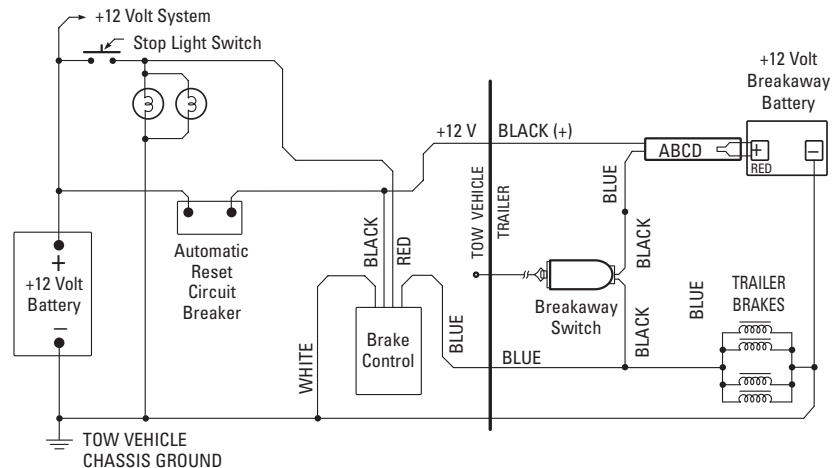

12 Volt Sealed Lead-Acid Battery

To maximize the life of the battery the following conditions should be met:

1. Avoid over or undercharge. This is the single worst enemy of lead-acid batteries.
2. Batteries should not be stored in a discharged state or at elevated ambient temperatures.
3. Avoid exposing batteries to heat! Service life is shortened considerably at ambient above 30°C (86°F).
4. Due to the characteristics of this battery, after six to nine months of storage, the battery should be recharged.
5. Charge the battery at the proper rate. Current should be limited to 1.2 amps or less.

* Refer to Breakaway Switch Installation Instructions for complete operating instructions and cautionary statements.

TRAILER BRAKE TROUBLESHOOTING

NO BRAKES

- Check for defective circuit breaker.
- Check for open or shorted circuit.
- Check for properly wired system, including a good ground between towing vehicle and trailer, not through trailer hitch.
- Check for defective controller or loose wiring at controller.
- Check brake adjustment.
- Check for defective resistor or loose wiring at resistor (hydraulic units only).
- Check for defective or worn magnet(s).
- Check for damaged or worn connector between towing vehicle and trailer.
- Ensure correct controller is installed.

INTERMITTENT OR SURGING BRAKES

- Check for defective circuit breaker.
- Check for out-of-round brake drums.
- Check for properly wired system, including a good ground between towing vehicle and trailer, not through trailer hitch.
- Check for defective magnets or magnet wiring.
- Check for loose or worn wheel bearings.

INEFFECTIVE OR WEAK BRAKES

- Insure trailer is not overloaded.
- Check for loose or corroded connections.
- Check for properly wired system, including a good ground between towing vehicle and trailer, not through trailer hitch.
- Check for shorted circuit.
- Check for proper variable resistor resistance (external resistor or controller) to trailer (for hydraulic units only).
- Worn or defective magnet.
- Check brake adjustment. Check for bent backing plate flange.
- Check for contaminated brake linings.
- Check brake system wiring to ensure proper gauge wiring is used. Ensure wiring is not connected through the stop light circuit.
- Check for worn, damaged or improper brake linings.
- Check for weak or broken brake shoe return spring.
- Check for defective or worn brake drums.
- Check for loose axle.
- Check that correct controller is installed.
- Improper controller installed or settings (level or gain).

GRABBING OR LOCKING BRAKES

- Check for improperly installed flanges.
- Check for contaminated brake linings (grease on linings).
- Check for weak or broken brake shoe return spring.
- Check for out-of-round brake drums.
- Ensure a variable resistor is installed (if necessary) (hydraulic units only).
- Check for variable resistor for proper resistance (hydraulic units only).

GRABBING OR LOCKING BRAKES (Continued)

- Check that correct controller is installed.
- Rust on armature plate or brake drum.
- Check for loose or worn wheel bearings.
- Improper controller installed position.
- Check for improper gain setting.
- Check for improper boost setting.

DRAGGING BRAKES

- Check brake adjustment.
- Check for defective controller.
- Check for improperly installed flange.
- Check for corroded brake assembly.
- Check for weak or broken brake shoe return spring.
- Check for worn or damaged lever arm between magnet and brake shoe.
- Improper controller installed position.

NOISY BRAKES

- Check brake adjustment.
- Check for worn brake shoes.
- Check for contaminated brake linings.
- Check for weak or broken shoe return springs.
- Check for bent backing plate.
- Check for improperly installed flange.
- Check wheel bearing adjustment.
- Check for worn or damaged wheel bearings.
- Check for worn or damaged magnets.

BRAKES LOCKED, BRAKE PEDAL NOT DEPRESSED

- Check stoplight switch adjustment.
- Check for short between stoplight switch circuit and power supply circuit.
- If brakes are locked when 4-way flashers are operated, check for Pulse Preventer installed in circuit.
- Check breakaway switch (pulled).

UNEVEN TIRE WEAR

Possibly due to: A bent or misaligned axle, Improper tire inflation. On tandem axle trailers, check voltage at front axle and rear axle with brakes applied. At times, the front axle will "lift" allowing front wheel to lock and slide. Correction can be made installing magnets with even resistance.

INOPERATIVE BREAKAWAY SWITCH

- Check for dead or weak 12-volt battery, on trailer.
- Check all wiring and connections.
- Check breakaway switch.
- If only one brake is operating, check other magnets.

TRAILER BRAKE ADJUSTMENT**

Brakes should be adjusted after the first 200 miles of operation when the brake shoes and drums have "seated" and at 3000 mile intervals, or as use and performance requires. The brakes should be adjusted in the following manner:

1. Jack up trailer and secure on adequate capacity jack stands. Follow trailer manufacturers recommendations for lifting and supporting the unit. Check that the wheel and drum rotate freely.
 - ⚠ **WARNING** Do not lift or support trailer on any part of the axle or the suspension system.
2. Remove the adjusting hole cover from the adjusting slot on the bottom of the brake backing plate.
3. With a screwdriver or standard adjusting tool, rotate the starwheel of the adjuster assembly to expand the brake shoes. Adjust the brake shoes out until the pressure of the linings against the drum makes the wheel very difficult to turn.

Note: With drop spindle axles, a modified adjusting tool with about an 80 degree angle should be used.
4. Then rotate the starwheel in the opposite direction until the wheel turns freely with a slight lining drag.
5. Replace the adjusting hole cover and lower the wheel to the ground.
6. Repeat the above procedure on all brakes.
 - ⚠ **WARNING** Never crawl under your trailer unless it is resting on properly placed jack stands.

Follow the trailer manufacturers recommendations for lifting and supporting the unit. Do not lift or place supports on any part of the suspension system.

**Note: Trailer Brake Adjustment procedures courtesy Dexter Axle.

Technical information is current as of the printing of this catalog. Contact technical service for periodic updates.

ELECTRIC TRAILER BRAKE PART IDENTIFICATION

Manufacturer Identification

AL-KO	AL-KO levers are very flat. The brake shoes do not have anything unusual about them. AL-KO uses only one return spring at the top on both 10 and 12-inch units. With the drum off, you can tell what size the system is if the magnets have never been replaced. The 10-inch brake will have a magnet with light green wires and the 12-inch brake will have white wires.
Dexter	Dexter uses a stamp on the back of the backing plate that identifies the size of the brake. Looking on the back side you will see a triangle. Around the triangle you will see Dexter and the size (i.e. 10" X 2 1/2" or 12" X 2"). Dexter uses 2 return springs on all late model brakes; some early 12-inch brakes used a single return spring.
Hayes	Hayes brake shoe webs have a tooth that hangs down at the top and use a single return spring. Early 12-inch brakes used a dual return spring. Hayes axle is owned by AL-KO. AL-KO backing plates have been seen on some of the new Hayes axles. It looks as if they are still using the Hayes name and are starting to use AL-KO parts.
Fayette	Fayette axles are obsolete. If you find a Fayette axle tag and the trailer is worth keeping you should consider changing the axles to AL-KO or Dexter. At that time it is recommended that the spring hangers and bushings also be replaced.

Brake Size Identification

Axle Identification	Axles generally have an ID tag located on the axle crossbar that gives you the axle capacity. Check there first. This would give you a starting reference point.
Brake Drum / Shoe Size	Measuring is the same for all brands. Using a tape measure you can do a random measurement as to the diameter by measuring across the drum. If it is a 10-inch drum you will measure approximately 11 inches across for an outside measurement. The 12-inch brake will measure approximately 13 inches for an outside measurement. The drum would need to be removed to get the correct diameter and width.

Magnet Identification

Magnets can be identified by the color of the wire used

Dexter 7" X 1 1/4"	The magnets are round. Prior to April 1990 they had yellow wires, after 1990 the magnet has white wires. Replacement of magnets will need to be done in pairs and updated to the new magnet along with the lever. The early levers are weak and will bend and hang up as they wear.
Dexter 10" X 1 1/2"	The magnet wires for the early model round magnets are white and the late model oval magnets are yellow.
Hayes 10" X 1 5/8"	The magnet wires for the early model round magnets are red and the late model oval magnets are green.
AL-KO 10" X 2 1/4"	It will have light green wires.
Hayes 10" X 2 1/4"	The early model round will have red wires and the late model will have oval green wires.
Dexter 10" X 2 1/4"	It uses green wires.
Fayette 10" X 2 1/4"	The round magnets will have white wires (obsolete).
AL-KO 12" X 2"	It will have white wires.
Hayes 12" X 2"	The early model round magnet will have red wires, the late model will be an oval magnet with white wires.
Dexter 12" X 2"	It will have white wires.
Dexter Centerline 12" X 2"	The 4.5K axles will have red orange wires, the 6/7K axles will have red wires (obsolete for both sizes).

BENCH TESTER INSTRUCTIONS

Many apparent brake control “failures” are the result of either faulty wiring or improper setup. The Tekonsha® Bench Tester is a test device designed to assist in determining if a brake control is working properly. This unit allows you to check a brake control for output, independent of vehicle wiring. The Bench Tester can simulate many fault conditions including open ground, short circuit, open load, and more.

To Use Bench Tester:

1. Turn off the power of the Bench Tester.
2. Disconnect the brake control from the tow vehicle.
3. Strip the insulation from the brake control's wires to about 1/4 inch and clip the matching color/function alligator clip of its corresponding stripped wire. **DO NOT REVERSE THE GROUND AND POWER WIRES AS YOU MAY PERMANENTLY DAMAGE THE BRAKE CONTROL**
4. Turn on the power of the Bench Tester.

If the control being tested is manufactured by Tekonsha:

1. The brake control's LED should glow green if it has a bi-colored LED. The display should show a “.c” if it has a digital readout. If you have the P3 brake control, you will see the Tekonsha logo. These conditions indicate a normal load connection.
2. Now set the brake control's power setting to maximum and actuate the control's manual override lever. The output voltage on the Bench Tester's voltmeter should read about 12 volts and the brake control LED display should glow bright red or show either 12 or 13. Release the manual lever. Lay the control on a flat surface and follow the directions for leveling the sensor per manufacturer's instructions.
3. Depress and hold the Bench Tester's brake switch.
 - A. If you are testing a proportional control, tilt the brake control by moving the front of the control up to about 30-45 degrees to fully activate the accelerometer. The voltage on the tester's meter should again read approximately 12V.

- B. If the control being tested is a time-actuated device, you will see the voltage progressively “ramp-up” to the control's maximum output.

NOTE: If the brake control works normally on the Bench Tester then the problem is likely in the vehicle wiring or the control setup. If you check the vehicle/trailer wiring and it appears to be normal you can refer to our product catalog or visit our web site for control setup and / or additional troubleshooting assistance.

⚠ CAUTION Tekonsha controls are built to withstand many electrical fault conditions without damage to their ultimate performance. Please be aware that some competitive products may not be capable of surviving the same punishment so care should be exercised when testing these units.

CURRENT MONITOR INSTRUCTIONS

The Current Monitor is a testing device designed to assist in determining whether a tow vehicle's trailer connector has been wired properly. This unit is also an excellent diagnostic tool for the installation, setup and troubleshooting of electric trailer brake controls and may be used to level and pre-set a brake control when a trailer is not available.

To Use Current Monitor:

1. Simply plug the tester into the vehicle's trailer connector.
2. Sitting in the driver's seat, position the switch (located between the amp meter & voltmeter gauges) to the “Trailer Brakes” position.
3. Then position the switch labeled “Number of Axles” to the appropriate position for the trailer that is expected to be towed.
4. Now, activate each function indicated by the four LED lights across the front of the test unit. Once it has been determined that all lighting connections are working properly, test the output of the vehicle's trailer brake control.

NOTE:

Be sure the brake control has been properly leveled per manufacturer's instructions.

5. Depress the vehicle's brake pedal and/or engage the brake control's manual override.
Brake Voltage must register at least 10 Volts. Brake Control Current Output should register at least:
12 Amps for two (2) axle trailers, or 18 Amps for three (3) axle trailers.

NOTE: If the brake control will not generate 18 or more amps when used with three or more axle trailers **BE SURE** that you are using a brake control designed to deliver this performance.

- If you discover a performance or wiring problem, look for one or more of the following fault conditions:
1. Improper wiring of the brake control to the vehicle's power and/or battery ground. (As with any electronic device, Horizon Global™ Electrical Products recommends grounding all brake controls directly to the vehicle battery to ensure the proper performance of the control's advanced circuitry.)
 2. Defective or improper wiring of the trailer connector.
 3. Broken, dirty or corroded trailer connector pins.

4. Open brake magnets, or open, broken or shorted wiring.
5. Defective brake control.

⚠ WARNING This unit contains magnets, which may become hot if the unit is left connected to an energized brake control for more than a few minutes.

Technical information is current as of the printing of this catalog. Contact technical service for periodic updates.

TRAILER TESTER INSTRUCTIONS

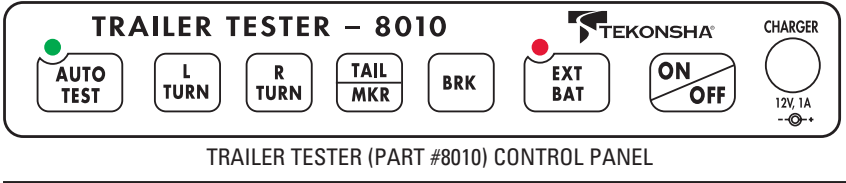

TRAILER TESTER (PART #8010) CONTROL PANEL

The Trailer Tester (Part #8010) is designed to help you quickly identify problems in the wiring of the trailer such as opens, shorts, incorrect wiring, etc. This is done by testing the Left Turn, Right Turn, Tail/Marker, Brake and Back Up circuits on the trailer, by indicating the approximate amount of current used in each circuit. It will also test the voltage of the external battery connected to the trailer charge circuit (i.e. trailer battery).

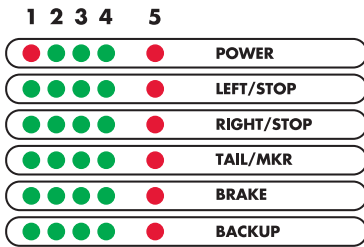

NOTE: The above LED light reference numbers are used in the following instructions for all rows.

READ THIS FIRST:

Read and follow all trailer warnings and installation instructions before continuing.

- Check to see that the mating surfaces of the trailer wiring connector matches the Trailer Tester connector. All connector surfaces should be clean and free of dirt. For proper operation, make sure the trailer tester battery is fully charged. Plug the trailer connector firmly into the Trailer Tester. Be sure that the connector is fully inserted.
- Turn the tester ON by pressing the ON button. All LEDs will cycle in order from top to bottom and left to right and will flash once. The tester is ready for use.
- INDICATOR "LED" LIGHTS – POWER ROW ONLY**
(Measuring the internal battery of the tester – LED will remain lit after power has been turned on)
 - Green LEDs 2, 3 and 4 mean that the internal battery is OK to perform tests.
 - Red LED 1 flashing means that the internal battery needs to be charged (see "Charging the Internal Battery" instructions below) or may need to be replaced.
 - Red LED 5 indicates that the battery is faulty or overcharged. Battery may need to be replaced.

4. CHARGING THE INTERNAL BATTERY

⚠ CAUTION

ONLY USE THE CHARGER (part no. 8008) PROVIDED WITH THE 8010 TESTER

- When the charger is plugged into the charger socket, Red LED 5 on the Power Row flashes if the unit is ON.
- If the unit is OFF, no LEDs will be lit, but the battery will still charge.
- The LED on the charger is RED while charging.
- The LED on the charger will turn GREEN when the battery is fully charged.

NOTE: The trailer tester will not function while the internal battery is being charged.

5. MANUAL AND AUTO TEST – LEFT/STOP, RIGHT/STOP, TAIL, BRAKE, BACKUP CHANNELS

AUTO TESTING (measuring the amount of load on each channel):

- Press the AUTO TEST button. When pressed, its indicator Green LED begins to flash.
- Each channel will be tested from top to bottom
- Red LED 5 will flash as its channel is tested
- Green LED(s) will remain ON to indicate the amount of load. (See Step 6 for LED display load readouts)
- See Step 7 for LED fault indication readouts.
- MANUAL TESTING (visual test of trailer lighting)
- Depressing any manual button will cause that same channel to flash 11 times. This will allow you to walk around the trailer and confirm that lights are functioning properly.
- The Trailer Tester will automatically shut down after three minutes to conserve the battery.
- See Step 7 for LED fault indication readouts.

NOTE: To CLEAR THE DISPLAY or TURN OFF AUTO TEST, simply press the auto test button. Then you are ready to test again.

6. HOW TO READ THE LED DISPLAY (for approximate load readouts) LEFT/STOP, RIGHT/STOP and BACKUP Load Readouts:

- Green LED 1 represents .25 amps
 - Green LED 2 represents 2 amps
 - Green LED 3 represents 3 amps
 - Green LED 4 represents 4 amps
- TAIL Load Readout:
- Green LED 1 represents .25 amps
 - Green LED 2 represents 4 amps

- Green LED 3 represents 6 amps
 - Green LED 4 represents 8 amps
- BRAKE Load Readout:
- Green LED 1 represents 1 axle
 - Green LED 2 represents 2 axles
 - Green LED 3 represents 3 axles
 - Green LED 4 represents 4 axles

NOTE: All current measurements are standard to RV.

7. FAULT INDICATION (See graph below)

- Red LED(s) 5 flashing on the affected channel represents: INTERCHANNEL SHORT OR REVERSED WIRES
 - Red LED 5 solid on the affected channel represents: NO LOAD/OPEN CIRCUIT
 - Green LEDs 1-4 and Red LED 5 all solid on the affected channel represents: OVERLOAD
 - Green LEDs 1-4 and Red LED 5 flashing on the affected channel represents: SHORT CIRCUIT TO GROUND
- ### 8. EXTERNAL BATTERY (Measures the trailer battery's (if present) open circuit voltage)
- Press the EXT BAT button. When pressed, its indicator Red LED will light.
 - Voltage will be displayed by lit LEDs in the Power Row only.
 - Green LED's 2 and 3 mean that the external battery has normal voltage.
 - Red LED 1 flashing means that the external battery needs to be charged or may need replacement.
 - Red LED 5 indicates that the battery is faulty or overcharged. Battery may need replacement.

NOTE: This test will automatically stop after a few seconds and the red light will go out.

NOTE: This test does not indicate the amount of charge left in the trailer battery. (Excludes breakaway battery)

FAULT INDICATION GRAPH

DISPLAY	1	2	3	4	5	HOW TO READ THE FAULT ON AN AFFECTED CHANNEL
● ● ● ●	●	●	●	●	⚡	INTER-CHANNEL SHORT BETWEEN THE FLASHING CHANNELS OR REVERSED WIRES
● ● ● ●	●	●	●	●	●	NO LOAD OPEN CIRCUIT
● ● ● ●	●	●	●	●	●	OVERLOAD
⚡ ⚡ ⚡	●	●	●	●	⚡	SHORT CIRCUIT TO GROUND
⚡ ● ● ●	●	●	●	●	●	LOW BATTERY, CHARGE OR REPLACE (POWER ROW ONLY)

LEGEND	
●	CONSTANT ON
⚡	RED LED FLASHING
○	RED LED OFF
●	GREEN LED ON
⚡	GREEN LED FLASHING
○	GREEN LED IS OFF

Technical information is current as of the printing of this catalog. Contact technical service for periodic updates.

AGRICULTURAL LIGHTING INFORMATION

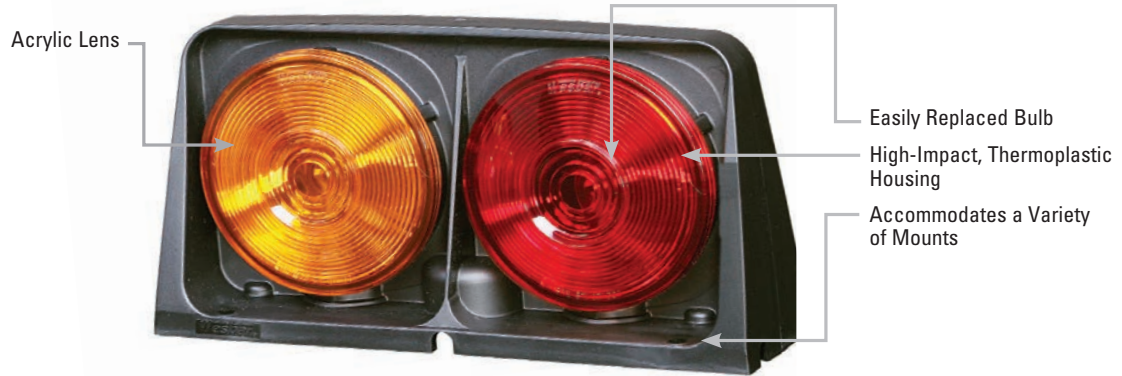

AG LIGHTS

Meet lighting standards for agricultural field equipment and improve high-way operating safety easily and cost effectively with AG Lights by Horizon Global. No other lighting package offers you the quality and dependability of AG Lights by Horizon Global. Designed specifically for the agricultural industry, AG Lights by Horizon Global withstand the most rigorous field and environmental conditions for long life and wear without repair. A variety of mounts enable easy and quick placement on all towable field equipment – harvesters, field cultivators, tillage equipment, forage boxes, and more.

- All lighting units are designed for easy customer repairs... right in the field. Pry out lenses with flat screwdriver for easy access to, and replacement of, the #1157 bulb.
- Five distinctly different light styles to meet your performance and styling requirements.

SAFETY IS KEY

Meet ASAE lighting recommendations for agricultural equipment and improve safety, while operating on highways easily and cost effectively, with AG Lights by Horizon Global. No other lighting package offers you the quality, durability, and reliability of AG Lights by Horizon Global. Designed specifically for the agricultural industry, these Heavy-Duty AG Lights, when combined with Horizon Global's AG Wiring, withstand the most rigorous field and environmental conditions for long life and wear.

ELECTRONIC ENHANCED AG LIGHTING MODULE

Horizon Global, known for innovation and product reliability, presents an electronic module to deliver the ASAE recommended "enhanced turn signal lighting" with conventional AG lights and a standard wiring scheme. This unit may be hard-wired into the AG lighting harness or coupled-in by use of a variety of plug assemblies.

Use of Horizon Global's electronic enhanced AG lighting module helps to meet the new ASAE standard cost effectively. It eliminates the need for special wedge-based bulbs and non-standard wire schemes to deliver the enhanced turn signal lighting called for by this ASAE standard.

Refer to the Standard AG Implement Enhanced Lighting Guide.

DURABLE, DEPENDABLE CONSTRUCTION OF HEAVY-DUTY AG LIGHTS

- High-impact, glass-filled thermoplastic housings deflect objects away from the lens area and prevent them from damaging or dislodging the lights assembly.
- Acrylic lenses.
- All fasteners provided are coated to resist rust.
- Bulb replacement, if ever needed, is simple – uses readily available standard automotive #1157 bulbs.

MULTIPLE MOUNTING OPTIONS

A variety of mounts enable suitable placement on tractors and all towable field equipment – harvesters, cultivators, tillage equipment, fertilizers, forage boxes, and more. Heavy-Duty AG Lights by Horizon Global have a patented design incorporating multiple mounting options and lighting combinations. Dual AG Light models provide amber flashing and turn indicators plus red tail light functions. Amber or red single lights provide maximum mount flexibility (vertically or horizontally) to meet applicable lighting requirements. All AG Lights by Horizon Global, except the grommeted series, are equipped with an exclusive molded weather-resistant low profile tri-plug. Custom plug configurations are also available.

USER-FRIENDLY DESIGN

- AG Harnesses are designed with a full-length ground circuit, from tractor to AG Lamp, assuring reliable and continuous operation.
- Each light's wiring is routed through a center port area, helping facilitate a variety of light placement.
- AG Lights by Horizon Global are available with a variety of connector options.
- Choose from mounting screws, bolts, or heavy-duty magnets to meet your mounting needs.

Additionally, an optional brake light function is available for dual light or single red-lensed models. This optional function is also needed on lights used with enhanced turn light systems. The brake light option is recommended when implements are to be towed by non-farm vehicles or tractors with brakes (brake lights).

AG SAFETY LIGHTING SYSTEMS

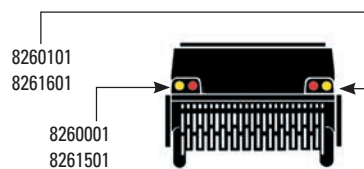

Horizontal, Upright Mount

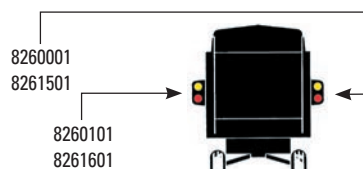

Vertical Mount

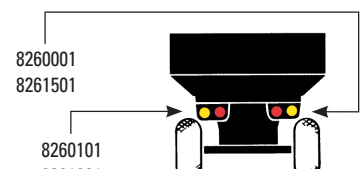

Horizontal, Inverted Mount

Technical information is current as of the printing of this catalog. Contact technical service for periodic updates.

STANDARD AG IMPLEMENT ENHANCED LIGHTING SCHEME

Under both the standard and enhanced lighting schemes, when traveling straight forward, the amber (outside) lights flash in unison with the tractor's amber lights on the high intensity at approximately 100 pulses per minute, and the low intensity of the red (inside) lights are on constantly.

With the standard wire harness in place, when a turn is being signaled, the amber light signaling the turn will increase flashing to approximately 120 pulses per minute with the amber light on the opposite side changing to a constant high intensity light. This mirrors the amber light on the tractor. Both red lights, however, remain on a constant low intensity.

To meet the enhanced lighting standard, introduce Electronic AG Light Enhanced Module to the implement's wire harness, and simply add red lights that have an active high intensity along with an additional RH and LH wire to these red lights. With this enhanced AG lighting system, during a turn the red light next to the amber turn side light will rapidly flash on the high intensity in unison with the amber light, and the red light on the opposite side will remain constant on the high intensity. This is a dramatic safety feature to better signal (to everyone) turns by tractors and implements.

AG LIGHTING WIRING DIAGRAM

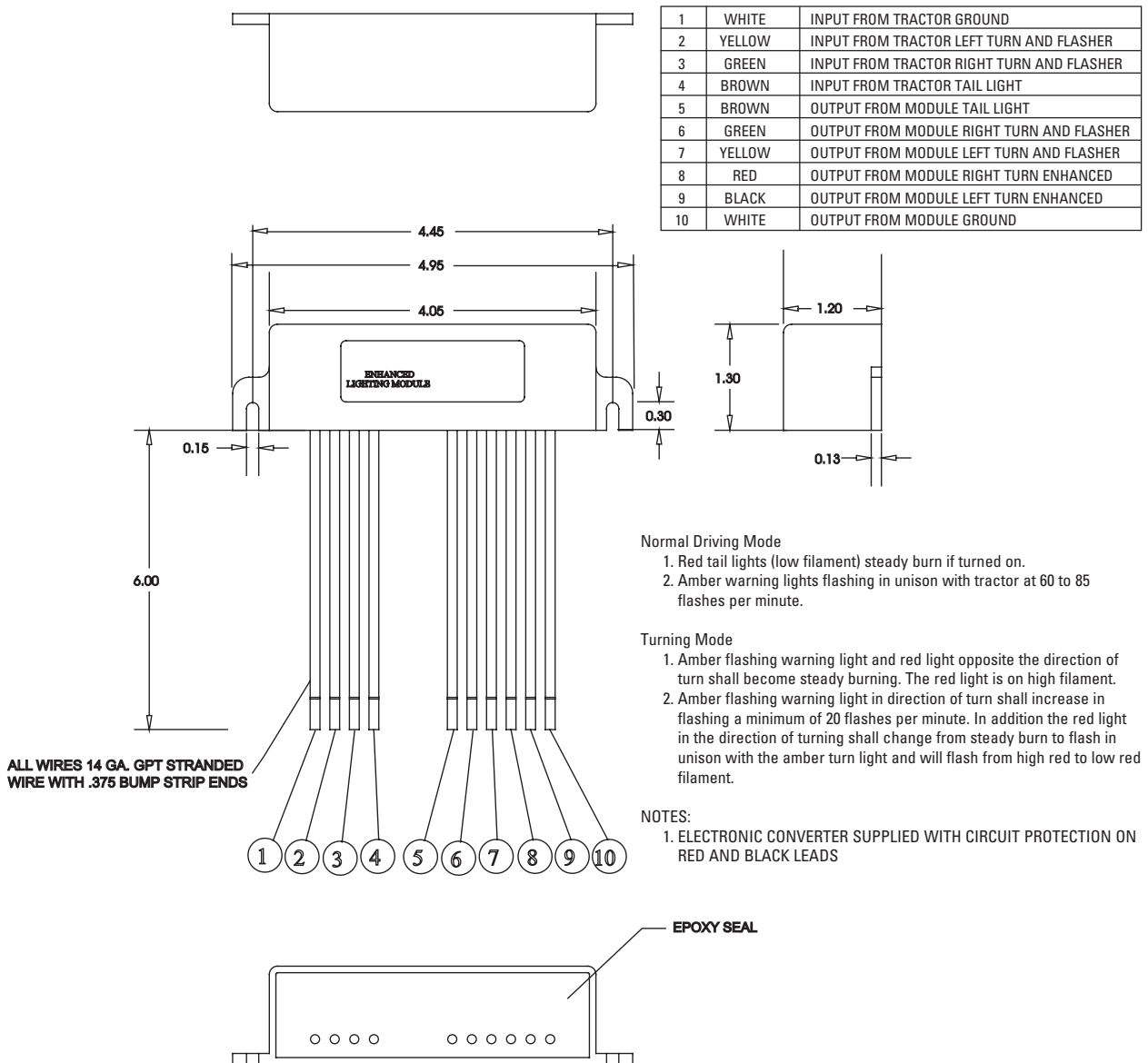

AG LIGHTING WIRING DIAGRAM WITH BRAKE

1	WHITE	INPUT FROM TRACTOR GROUND
2	RED	INPUT FROM TRACTOR BRAKE SIGNAL
3	YELLOW	INPUT FROM TRACTOR LEFT TURN AND FLASHER
4	GREEN	INPUT FROM TRACTOR RIGHT TURN AND FLASHER
5	BROWN	INPUT FROM TRACTOR TAIL LIGHT
6	BROWN	OUTPUT FROM MODULE TAIL LIGHT
7	GREEN	OUTPUT FROM MODULE RIGHT TURN AND FLASHER
8	YELLOW	OUTPUT FROM MODULE LEFT TURN AND FLASHER
9	RED	OUTPUT FROM MODULE RIGHT TURN ENHANCED & BRAKE SIGNAL
10	BLACK	OUTPUT FROM MODULE LEFT TURN ENHANCED & BRAKE SIGNAL
11	WHITE	OUTPUT FROM MODULE GROUND

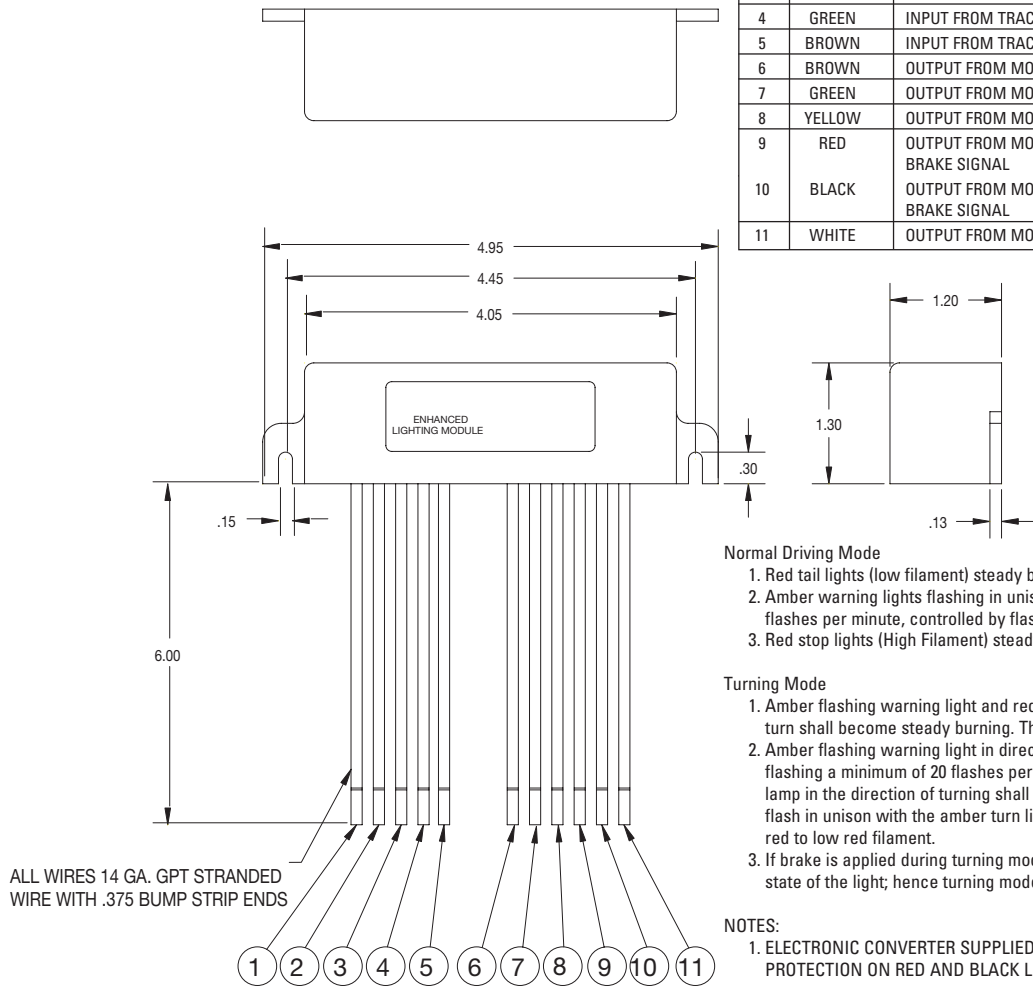

Technical information is current as of the printing of this catalog. Contact technical service for periodic updates.

TRAILER FEDERAL LIGHTING EQUIPMENT LOCATION REQUIREMENTS

IMPORTANT NOTE: Every lamp, reflex reflector, and conspicuity treatment must be permanently attached in the location specified below and must comply with all applicable requirements prescribed for it by FMVSS/CMVSS 108. The face of any device on the front/rear and sides should be, respectively perpendicular and parallel to the vehicle's centerline, unless it is photometrically certified at instal-

lation angle. No part of the vehicle shall prevent any device from meeting its prescribed requirements unless an auxiliary device meeting all prescribed requirements is installed. In Canada: Manufacturers and importers of vehicles must have the proper certification test records demonstrating compliance of lighting components with all prescribed requirements.

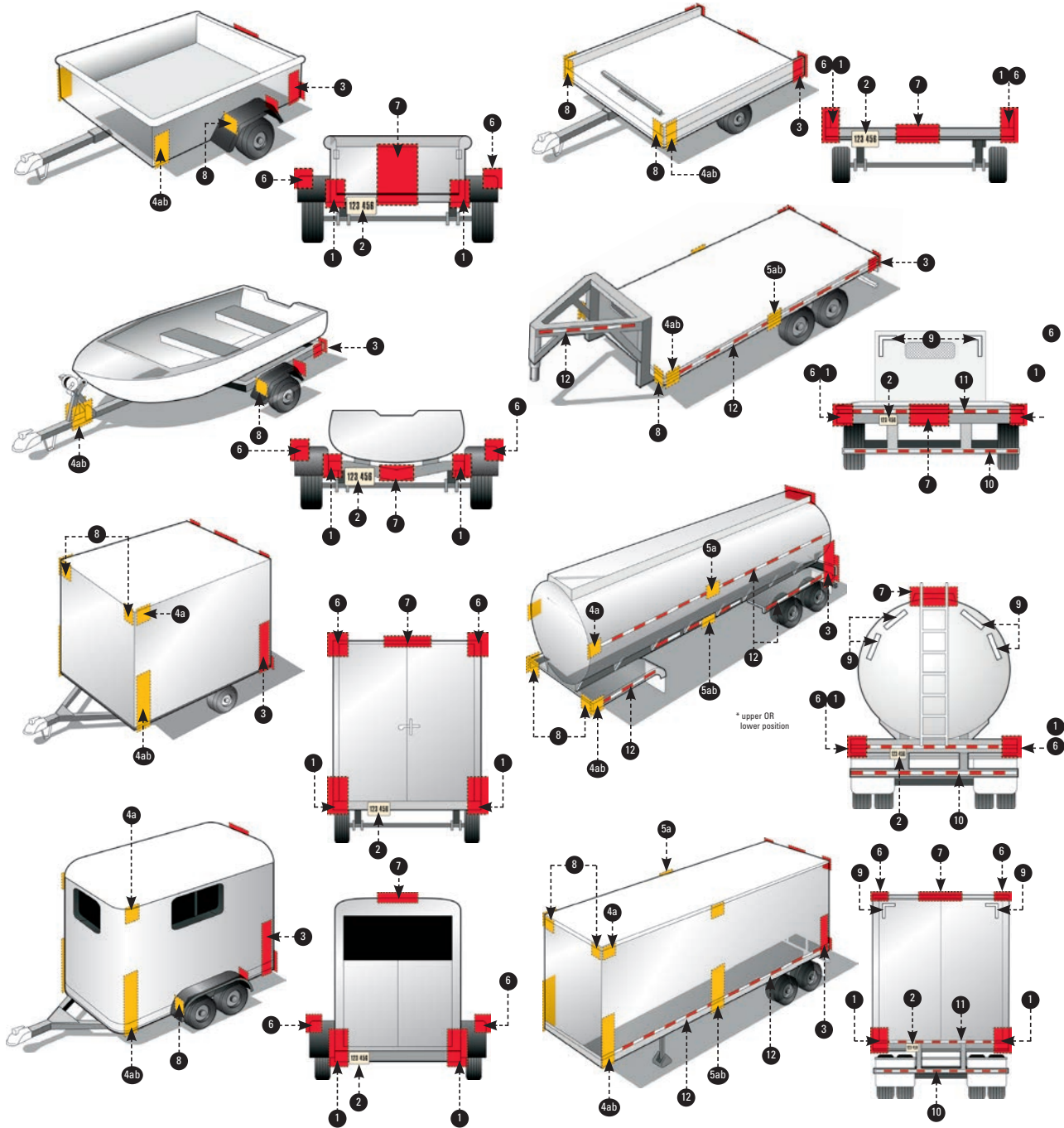

This table summarizes lighting equipment requirements contained in Federal/Canada Motor Vehicle Safety Standard 108. While Horizon Global believes this to be an accurate summary of the latest printed information, the actual standard should be consulted for design or other such purposes. For complete compliance requirements consult Title 49 - Code of Federal Regulations-Section 571.108 (USA) or Section 108 of the Motor Vehicle Safety Regulations (Canada). State or Provincial regulations, where they may apply, have not been included.

TRAILER FEDERAL LIGHTING EQUIPMENT LOCATION REQUIREMENTS

BASIC EQUIPMENT REQUIRED ON ALL TRAILERS

DESCRIPTION				MANDATORY REQUIREMENTS			
Area	Equipment	SAE Lens Coding	Functional Purpose	Quantity	Color	Location	Height mm(in.) from the ground
1	Tail Lamps	(T)	Indicate vehicle's presence and width	Minimum 2	Red	On the rear - symmetrical as far apart as practicable	380-1830 (15-72)
	Stop Lamps	(S)	Indicate braking	Minimum 2	Red	On the rear - symmetrical as far apart as practicable	380-1830 (15-72)
	Rear Turn Signal Lamps	(I)	Indicate direction of turn	Minimum 2	Red or Yellow	On the rear - symmetrical as far apart as practicable	380-2110 (15-83)
	Rear Reflex Reflectors	(A)	Indicate vehicle's presence and width	Minimum 2	Red	On the rear - symmetrical as far apart as practicable facing rearward	380-1530 (15-60)
2	License Plate Lamp(s)	(L)	Illuminates license plate	Minimum 1	White	On the rear - above or at the sides of license plate	No requirement
3	Rear Side Marker Lamps <small>*photometrically certified at installation angle</small>	(P2, PC* or P3, PC2*)	Front and rear side marker lamps / side reflex reflectors indicate vehicle's presence and length	Minimum 2	Red	Each side at rear as far back as practicable	380-1530 (15-60) no max. for veh. under 2032mm (80") wide
	Rear Side Reflex Reflectors	(A)		Minimum 2	Red facing sideward	Each side at rear as far back as practicable	380-1530 (15-60)
4	a Front Side Marker Lamps <small>*photometrically certified at installation angle</small>	(P2, PC* or P3, PC2*)	Front and rear side marker lamps / side reflex reflectors indicate vehicle's presence and length	Minimum 2	Yellow	Each side at front as far forward as practicable	380 (15) minimum
	b Front Side Reflex Reflectors	(A)		Minimum 2	Yellow	Each side at front as far forward as practicable facing sideward	380-1530 (15-60)

ADDITIONAL EQUIPMENT FOR TRAILERS EXCEEDING THE FOLLOWING PARAMETERS

Length 9.1m (30 ft.) or longer

DESCRIPTION				MANDATORY REQUIREMENTS			
Area	Equipment	SAE Lens Coding	Functional Purpose	Quantity	Color	Location	Height mm(in.) from the ground
5	a Intermediate Side Marker Lamps	(P2 or P3)	Indicate presence of a long vehicle	Minimum 2	Yellow	Each side near center facing sideward	380 (15) minimum
	b Intermediate Side Reflex Reflectors	(A)	Indicate presence of a long vehicle	Minimum 2	Yellow	Each side near center facing sideward	380-1530 (15-60)

Width 2032mm (80 in.) or wider

DESCRIPTION			MANDATORY REQUIREMENTS				
Area	Equipment	SAE Lens Coding	Functional Purpose	Quantity	Color	Location	Height
6	Rear Clearance Lamps <small>*photometrically certified at installation angle with tail lamps</small>	(P2, PC* or P3, PC2*)	Show vehicle's width MAY NOT be combined	Minimum 2	Red facing rearward	At widest point - symmetrical on the rear or near the rear ID lamps are at the top	As high as practicable may be lower only if
7	Rear Identification (ID) Lamps	(P2 or P3)	Indicate presence of a wide vehicle	Exactly 3	Red	On the rear - center horizontally spaced 150mm (6 in.) to 300mm (12 in.) apart facing rearward	At the top - may be lower if door header narrower than 25mm
8	Front Clearance Lamps <small>*photometrically certified at installation angle</small>	(P2, PC* or P3, PC2*)	Show vehicle's width	Minimum 2	Yellow facing forward	At widest point - symmetrical on the front or near the front	As high as practicable

Width 2032mm (80 in.) or wider AND GVWR 4536 kg (10,000 lb.) or more

DESCRIPTION			MANDATORY REQUIREMENTS				
Area	Conspicuity Treatment	DOT Coding	Quantity	Color	Location	Height	Options
9	Rear Upper Body Markings		Exactly 2 pairs of 300mm long strips	White	On the rear upper corners facing rearward	At the top	
10	Bumper Bar Marking	DOT-C DOT-C2 DOT-C3 DOT-C4	Continuous	Red/White	On the rear bumper bar's horizontal element full width - facing rearward	No requirement	
11	Rear Lower Body Marking		Continuous	Red/White (see options)	On the rear full width of the vehicle facing rearward	As horizontal as practicable and as close as practicable to the range of 375 to 1525mm from the ground	
12	Side Marking		(see location)	Red/White (see options)	Each side - facing sideward continuous, or evenly spaced over minimum of 50% of length starts and ends as close to the front and rear of the vehicle as practicable	As horizontal as practicable and as close as practicable to the range of 375 to 1525mm from the ground	

NOTE: The edge of red conspicuity tape shall not be closer than 75 mm to the edge of any amber lamp and the edge of white conspicuity tape shall not be closer than 75 mm to the edge of any lamp

TRUCK FEDERAL LIGHTING EQUIPMENT LOCATION REQUIREMENTS

IMPORTANT NOTE: Every lamp, reflex reflector, and conspicuity treatment must be permanently attached in the location specified below and must comply with all applicable requirements prescribed for it by FMVSS/CMVSS 108. The face of any device on the front/rear and sides should be, respectively perpendicular and parallel to the vehicle's centerline, unless it is photometrically certified at installation angle. No part of the

vehicle shall prevent any device from meeting its prescribed requirements unless an auxiliary device meeting all prescribed requirements is installed. In Canada: Manufacturers and importers of vehicles must have the proper certification test records demonstrating compliance of lighting components with all prescribed requirements.

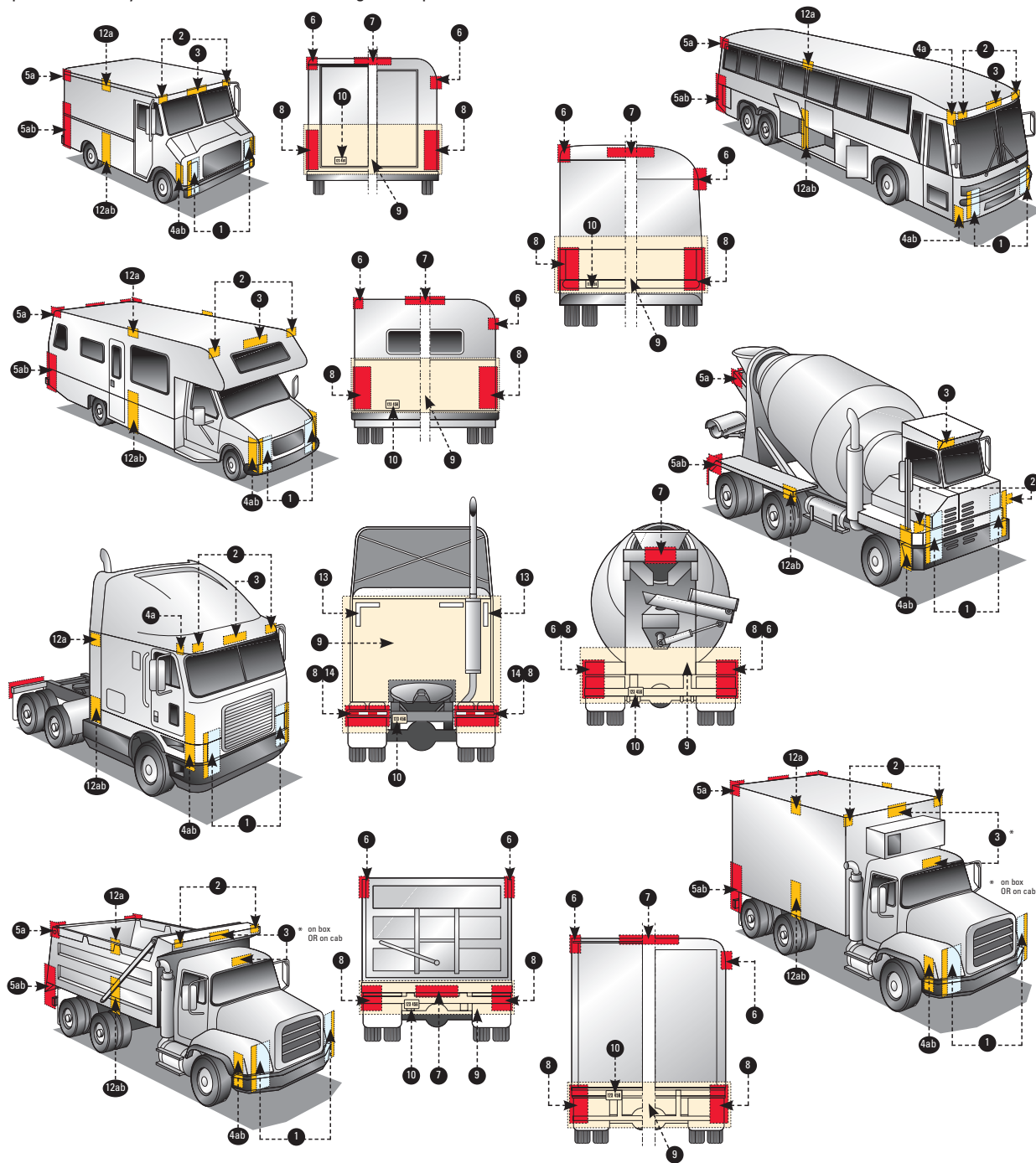

This table summarizes lighting equipment requirements contained in Federal/Canada Motor Vehicle Safety Standard 108. While Horizon Global believes this to be an accurate summary of the latest printed information, the actual standard should be consulted for design or other such purposes. For complete compliance requirements consult Title 49 - Code of Federal Regulations-Section 571.108 (USA) or Section 108 of the Motor Vehicle Safety Regulations (Canada). State or Provincial regulations, where they may apply, have not been included.

TRUCK FEDERAL LIGHTING EQUIPMENT LOCATION REQUIREMENTS

BASIC EQUIPMENT REQUIRED ON ALL TRUCKS, BUSES & MPVs

DESCRIPTION				MANDATORY REQUIREMENTS			
Area	Equipment	SAE Lens Coding	Functional Purpose	Quantity	Color	Location	Height mm(in.) from the ground
1	Headlamps - Lower Beam US requires "DOT" lettering on lens US&Canada - light source code required on lens	(H, HR)	Forward road illumination	Minimum 2 If 4 lamp system - outboard or above upper beams	White	On the front - symmetrical as far apart as practicable	560-1370 (22-54)
	Headlamps - Upper Beam US requires "DOT" lettering on lens US&Canada - light source code required on lens	(H, HR)	Forward road illumination	Minimum 2	White	On the front - symmetrical If 4 lamp system - inboard or below lower beams	560-1370 (22-54)
	Parking Lamps Vehicles less than 2032mm wide	(P)	Indicate parked vehicle	Minimum 2	White or Yellow	On the front - symmetrical as far apart as practicable	380-1830 (15-72)
	Daytime Running Lamps (DRL) Canada - required / US - option US requires "DRL" lettering on lens if not headlamp	(Y2)	Indicate in use vehicle	Minimum 2	White or Yellow	On the front - symmetrical as far apart as practicable on type of DRL	380 (15) min. Max. depends
	Front Turn Signal/Hazard Warning Lamps	(I)	Indicate direction of turn/identify disabled vehicle	Minimum 2	Yellow	On the front - symmetrical as far apart as practicable	380-2110 (15-83)
2	Front Clearance Lamps Vehicles 2032mm wide or wider *photometrically certified at installation angle	(P2, PC* or P3, PC2*)	Show vehicle's width	Minimum 2	Yellow	At widest point - symmetrical on the front or near the front facing forward	As high as practicable
3	Front Identification Lamps (ID) Vehicles 2032mm wide or wider	(P2 or P3)	Indicate presence of a wide vehicle	Exactly 3	Yellow	On the front - center horizontally spaced 150 mm (6 in.) to 300 mm (12 in.) apart	As high as practicable or on top of the cab
4	a Front Side Marker Lamps *photometrically certified at installation angle	(P2, PC* P3, PC2*)	Front and rear side marker lamps / side reflex reflector indicate vehicle's presence and length	Minimum 2	Yellow	Each side at front as far forward as practicable	380 (15) minimum
	b Front Side Reflex Reflectors	(A)		Minimum 2	Yellow	Each side at front as far forward as practicable facing sideward	380-1530 (15-60)
5	a Rear Side Marker Lamps ** *photometrically certified at installation angle	(P2, PC* or P3, PC2*)		Minimum 2	Red	Each side at rear as far back as practicable	380 (15) minimum
	b Rear Side Reflex Reflectors ** **not required on Truck Tractors	(A)		Minimum 2	Red	Each side at rear as far back as practicable facing sideward	380-1530 (15-60)
6	Rear Clearance Lamps Vehicles 2032mm wide or wider Not required on Truck Tractors *photometrically certified at installation angle	(P2, PC* or P3, PC2*)	Show vehicle's width MAY NOT be combined with tail lamps	Minimum 2	Red	At widest point - symmetrical on the rear or near the rear facing rearward	As high as practicable may be lower only if rear ID lamps are at the top
7	Rear Identification (ID) Lamps Vehicles 2032mm wide or wider Not required on Truck Tractors	(P2 or P3)	Indicate presence of a wide vehicle	Exactly 3	Red	On the rear - center horizontally spaced 150mm (6 in.) to 300mm (12 in.) apart facing rearward	At the top may be lower if too narrower than 25mm
8	Tail Lamps	(T)	Indicate vehicle's presence and width	Minimum 2	Red	On the rear - symmetrical as far apart as practicable	380-1830 (15-72)
	Stop Lamps	(S)	Indicate braking	Minimum 2	Red	On the rear - symmetrical as far apart as practicable	380-1830 (15-72)
	Rear Turn Signal/Hazard Warning Lamps	(I)	Indicate direction of turn/identify disabled vehicle	Minimum 2	Red or yellow	On the rear - symmetrical as far apart as practicable	380-2110 (15-83)
	Rear Reflex Reflectors	(A)	Show vehicle's presence and width	Minimum 2	Red	On the rear - symmetrical as far apart as practicable	380-1530 (15-60)
9	Backup Lamp	(R)	Illuminates ground behind the vehicle and alert road users	Minimum 1	White	Rear	No requirement
10	License Plate Lamp(s)	(L)	Illuminates license plate	Minimum 1	White	On the rear - above or at the sides of license plate	No requirement
11	Center High Mounted Stop Lamp Vehicles less than 2032mm wide and 4536kg	(U3)	Indicates braking	1	Red	On the rear - centerline of the vehicle	860 (34) minimum

ADDITIONAL EQUIPMENT FOR SPECIFIC VEHICLES VEHICLES 9.1m (30 ft.) LONG OR LONGER

DESCRIPTION				MANDATORY REQUIREMENTS			
Area	Equipment	SAE Lens Coding	Functional Purpose	Quantity	Color	Location	Height mm(in.) from the ground
12	a Intermediate Side Marker Lamps	(P2 or P3)	Indicate presence of a long vehicle	Minimum 2	Yellow	Each side near center	380 (15) minimum
	b Intermediate Side Reflex Reflectors	(A)	Indicate presence of a long vehicle	Minimum 2	Yellow	Each side near center facing sideward	380-1530 (15-60)

Truck Tractors

DESCRIPTION		MANDATORY REQUIREMENTS					
Area	Conspicuity Treatment	DOT Coding	Quantity	Color	Location	Height	Options
13	Rear Upper Body Markings	DOT-C DOT-C2 DOT-C3 DOT-C4	Exactly 2 pairs of 300mm long strips	White	Rear upper corners of cab facing rearward	As high as practicable excluding fairings	
14	Rear Marking		Exactly 2 sections of min. 600mm each	Red/White	Rear - facing rearward - on fenders, on mud flap brackets, or within 300mm below the top of mud flaps	As horizontal as practicable and not higher than 1525mm from the ground	If mud flaps not used - on the cab or frame mounted brackets

NOTE: The edge of red conspicuity tape shall not be closer than 75 mm to the edge of any amber lamp and the edge of white conspicuity tape shall not be closer than 75 mm to the edge of any lamp

WELD-ON BRACKET MOUNTING POSITIONS FOR F2® JACKS

3x3 Tube With 3x4 Plate

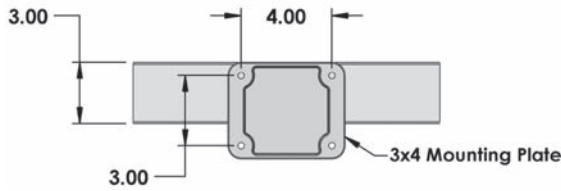

3x4 Tube With 3x4 Plate

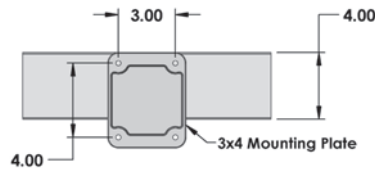

Part Number	F2 MARINE AND RECREATIONAL JACKS
1413060334	F2 Twin Track Model 3"x 4" Pivot Housing. Includes Handle Hold-up Feature & Weld-on Mounting Bracket & Hardware.
1413050334	F2 Wide Track Model 3"x 4" Pivot Housing. Includes Handle Hold-up Feature & Weld-on Mounting Bracket & Hardware.
500277	Pivot Housing.

Part Number	F2 MARINE AND RECREATIONAL JACKS
1413060334	F2 Twin Track Model 3"x 4" Pivot Housing. Includes Handle Hold-up Feature & Weld-on Mounting Bracket & Hardware.
1413050334	F2 Wide Track Model 3"x 4" Pivot Housing. Includes Handle Hold-up Feature & Weld-on Mounting Bracket & Hardware.
500277	Pivot Housing.

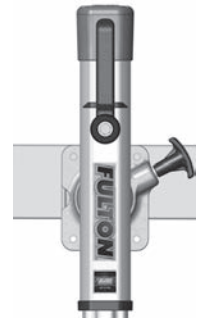

3x5 Tube With 4x5 Plate

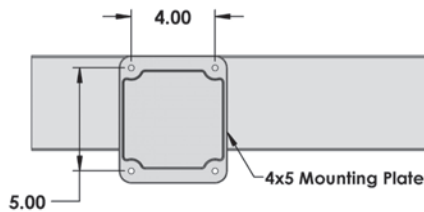

3x5 Tube With 3x4 Plate

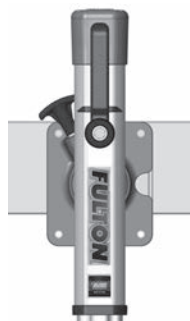
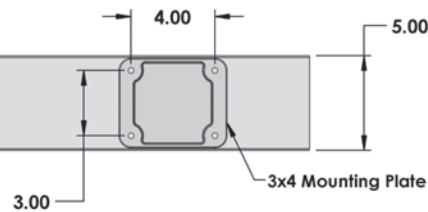

Part Number	F2 MARINE AND RECREATIONAL JACKS
1413200334	Adjustable Swivel w/ Footplate Includes Handle Hold-up Feature & Weld-on Mounting Bracket & Hardware for up to 5" Frames.
500276	Pivot Housing.

Part Number	F2 MARINE AND RECREATIONAL JACKS
1413060334	F2 Twin Track Model 3"x 4" Pivot Housing. Includes Handle Hold-up Feature & Weld-on Mounting Bracket & Hardware.
1413050334	F2 Wide Track Model 3"x 4" Pivot Housing. Includes Handle Hold-up Feature & Weld-on Mounting Bracket & Hardware.
500277	Pivot Housing.



ADJUSTING THE SWIVEL MOUNT HEIGHT FOR F2® JACKS

Required Tools:

3/4 Socket, Ratchet Wrench, Torque wrench.

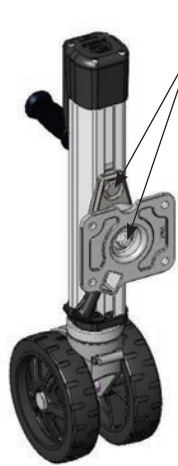

Adjusting Swivel Mount Height (If Necessary):

With jack removed from trailer, loosen the two swivel fasteners until the slide block moves freely along outer tube. To access the upper bolt be sure the swivel bracket is rotated in the horizontal (3" mounting) position as shown. Adjust swivel mount to desired location and re-torque to 60-70 ft-lbs. After adjustment, check for proper swivel and pin engagement.

Loosening factory torqued nuts and bolts on your swivel mount:

1. Cover your work area with a piece of cardboard or a towel to protect the finish on your jack.
2. Position the jack firmly on a bench at waist level.
3. Turn mounting bracket so that the pull pin is toward the caster(s).
4. Brace the gearbox against your hip and firmly grip the caster.
5. Loosen the half inch nut inside the swivel mount by pulling toward your body.

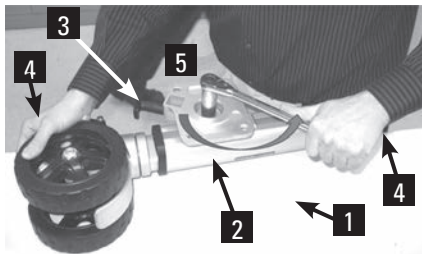

6. Remove the nut from the back of the swivel mount.

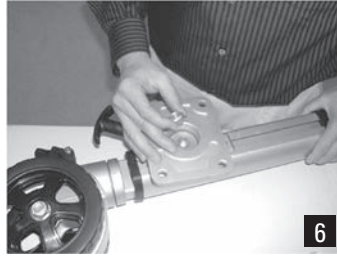

7. Pull the pull pin and remove the swivel mount.

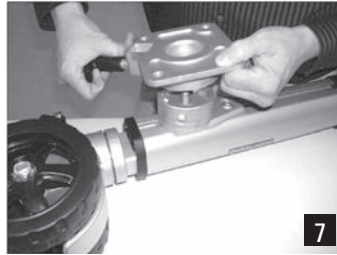

8. Loosen the standard hex bolt with the 5/16 hex wrench.

9. Adjust the mount height.

10. Re-torque the nut on the slide block to 60 ft-lbs.

Final Steps:

11. Replace the swivel mount making sure that the washer is still in place.

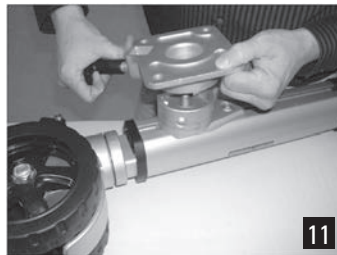

12. Replace the nut on the back of the swivel mount.

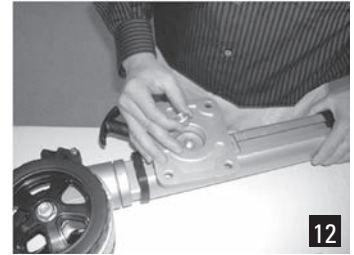

13. Re-torque the nut on the back of the swivel mount to 60 ft-lbs.

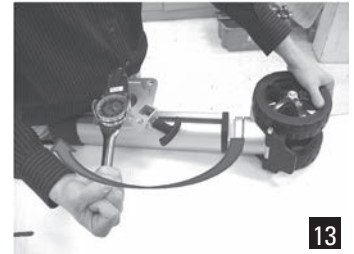

14. You are now ready to enjoy your Fulton F2 Jack.



Technical information is current as of the printing of this catalog. Contact technical service for periodic updates.

JACK REPLACEMENT QUICK REFERENCE GUIDE

NOTES: This Quick Reference Guide is not intended to supplement your original jack instruction sheet. This guide is only intended to help identify your jack for purposes of service and part replacement.

While servicing your jack, make sure it is not under load.

Replacement parts are intended for worn jack parts. If your jack has been damaged, replace it to prevent unsafe conditions.

Help us help you!

To ensure you receive the most accurate, prompt service possible, collect as much of the following information as possible before calling. If more than one item in a group seems to fit your jack, note all that apply and what about your jack that makes it fit that category. Some helpful pictures are shown at the bottom of the next page.

Jack Series and Capacity (Available on product label or in stamped marking)

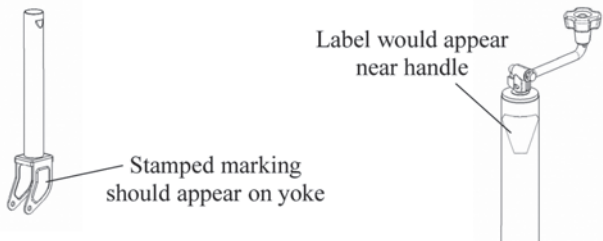

Handle Style (Available by inspection)

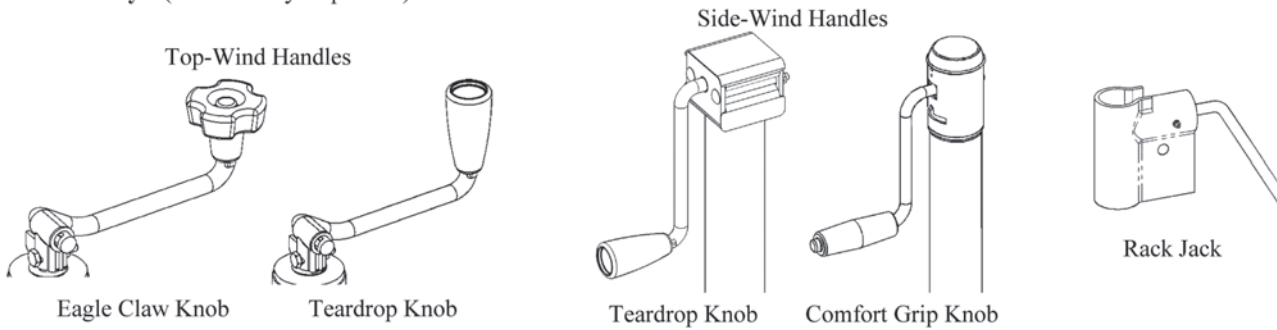

Plunger Pin Size (Available by inspection, not a feature on all jack models)

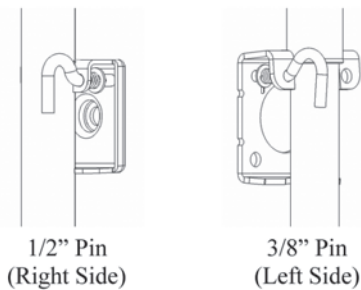

Mount Type (Available by inspection. Note if your mount is welded or bolted to your trailer tongue.)

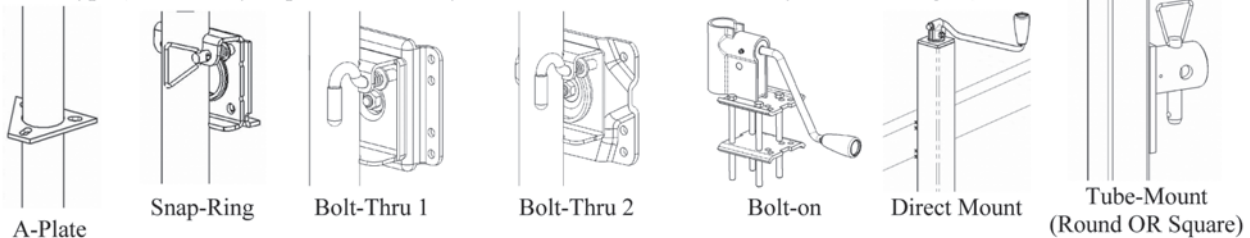

Technical information is current as of the printing of this catalog. Contact technical service for periodic updates.

WHOLE JACK EXAMPLES

Foot/Wheel Type (Available by inspection)



Removable Wheel
(Wheels may also be fixed to the jack)



Removable Foot
(Feet may also be fixed to the jack)



No Foot

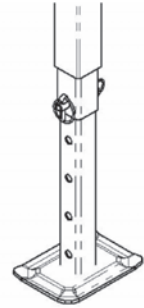

Drop Leg

Some Examples of whole jacks are below

Top-Wind,
Eagle Claw Knob,
1/2" Plunger Pin,
Snap-Ring Mount,
Fixed Regular Foot



Side-Wind,
Teardrop Knob,
Internal Gearbox,
1/2" Plunger Pin,
Bolt-Thru I Mount,
No Foot

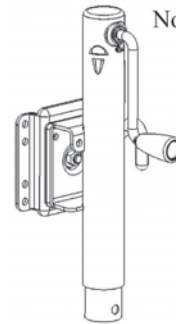

Rack Jack,
Teardrop Knob,
Bolt-on

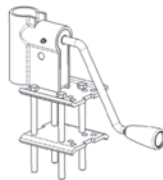

Top-Wind,
Eagle Claw Knob,
A-Plate,
Removable Wheel



Side-Wind,
Teardrop Knob,
External Gearbox,
Tube Mount,
Fixed Large Foot

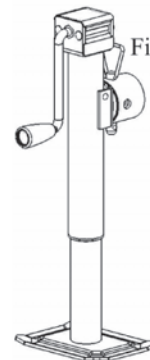

Technical information is current as of the printing of this catalog. Contact technical service for periodic updates.

JACK ASSEMBLY QUICK REFERENCE GUIDE

Assembly Quick-Reference Guide

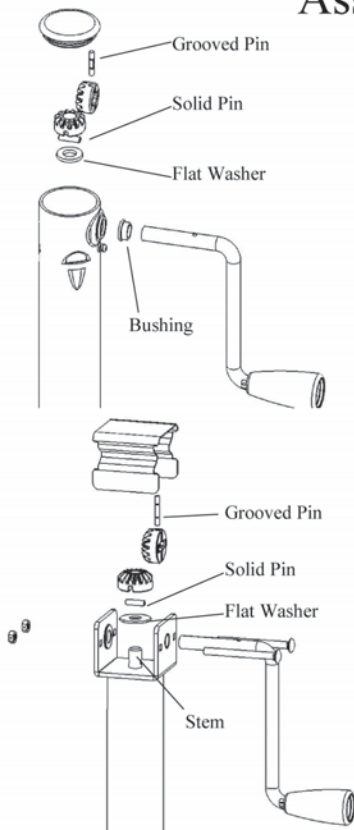

Side-Wind Jack Assembly:

- 1) Carefully remove all parts from the gearbox. The grooved pin is very secure in place and you may need to rotate the jack handle to reveal and remove it.
- 2) Place the flat washer over stem at the bottom of the gearbox.
- 3) Place the solid pin through the hole in the stem and place the gear over the solid pin so that the solid pin rests in the slot on the gear that does NOT go across the entire gear. The lower gear should be the larger of the two gears if the gears are a different size.
- 4) If you have an internal gearbox, install the bushing from inside the jack tube.
- 5) Insert the handle through the bushing and the second gear. Be sure the gear teeth are fully engaged and the handle is sticking out the far side of the jack after this step.
- 6) The grooved pin must now be inserted through the second gear and the handle. It may be necessary to rotate the handle 1/4 turn to expose the hole in the handle. The groove pin will fit very tightly and should be installed carefully to avoid damage to the jack body. Make sure the pin is centered in the handle to ensure smooth cranking.
- 7) Re-install the cap with even pressure, or with the bolts and nuts as it was removed.
- 8) Be sure the jack is assembled properly and functions as new before using it to support a load.

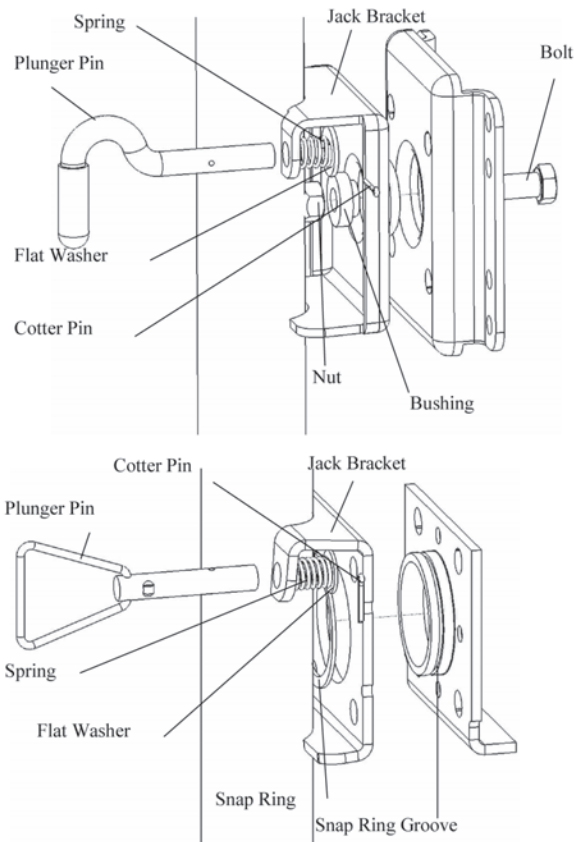
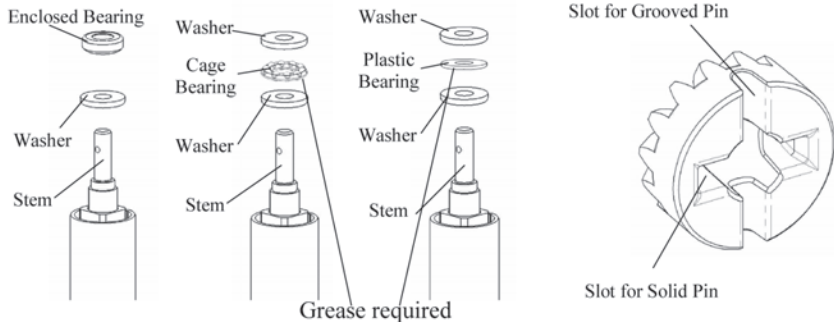

Bolt-Thru Assembly:

Place the jack bracket into the recessed opening of the mount. Place the small end of the bushing into the jack bracket and onto the bolt. Tighten until there is little movement in the bushing.

Snap Ring Assembly:

Place the jack bracket over the mount so that the snap ring groove is reachable on the inside of the jack bracket. Insert the snap ring into the groove. Be sure the snap ring is fully seated in the groove.

Plunger Pin Assembly:

First select the appropriate hole for the plunger pin. When viewing the jack from the crank side, 3/8" pins fit into the left hole, 1/2" plunger pins fit into the right hole. Also check that the mating bracket has the correct size holes in it.

- 1) Start the plunger pin through the jack bracket and place the spring and washer on the plunger pin before fully inserting the plunger pin through the jack bracket.
- 2) The spring and washer must be compressed to allow the cotter pin to be properly inserted into the plunger pin.
- 3) Be sure the jack is assembled properly and functions as new before bending the cotter pin to secure the plunger pin assembly and before using it to support a load.

Technical information is current as of the printing of this catalog. Contact technical service for periodic updates.

ELECTRIC WINCH PERFORMANCE DATA AND DIMENSIONS

DC6000 - 6,000 LBS.

PERFORMANCE DATA

LINE SPEED AND AMP. DRAW

LINE PULL LB / KG	SPEED FPM / MPM	12V AMPS
NO LOAD	26.2 / 8.0	60
2,000 / 907	17 / 5.2	150
4,000 / 1,814	10.2 / 3.1	240
6,000 / 2,722	6.5 / 2	300

LINE PULL AND ROPE CAPACITY

LAYER OF ROPE	PULL BY LAYER LB / KG	TOTAL ROPE ON DRUM FT / M
1st	6,000 / 2,722	12.5 / 3.8
2nd	4,995 / 2,266	27.5 / 8.4
3rd	4,279 / 1,941	45 / 13.7
4th	3,742 / 1,698	65.1 / 19.8

DIMENSIONS

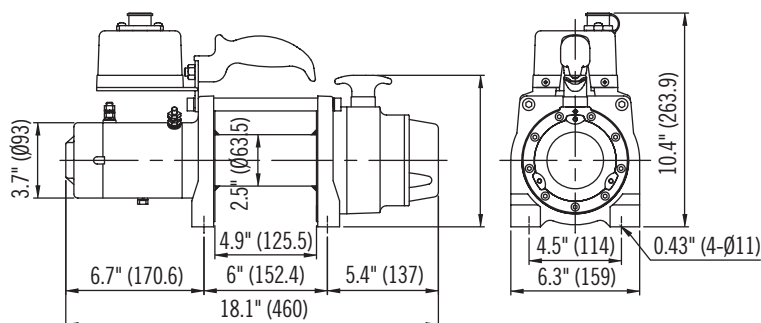

DC9000 - 9,000 LBS.

PERFORMANCE DATA

LINE SPEED AND AMP. DRAW

LINE PULL LB / KG	SPEED FPM / MPM	12V AMPS
NO LOAD	44 / 13.4	55
2,000 / 907	15 / 4.6	110
4,000 / 1,814	11 / 3.4	200
6,000 / 2,722	9 / 2.7	230
9,000 / 4,082	6.4 / 2	350

LINE PULL AND ROPE CAPACITY

LAYER OF ROPE	PULL BY LAYER LB / KG	TOTAL ROPE ON DRUM FT / M
1st	9,000 / 4,083	17.7 / 5.4
2nd	7,310 / 3,316	40 / 12.2
3rd	6,154 / 2,792	67.3 / 20.5
4th	5,314 / 2,410	82 / 25

DIMENSIONS

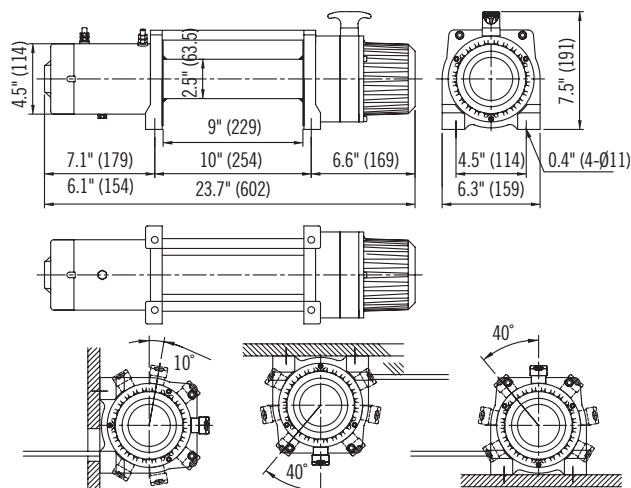

DC12000L - 12,000 LBS. LIGHT

PERFORMANCE DATA

LINE SPEED AND AMP. DRAW

LINE PULL LB / KG	SPEED FPM / MPM	12V AMPS
NO LOAD	26.2 / 8	50
4,000 / 1,814	9.8 / 3	120
8,000 / 3,629	5 / 1.5	230
10,000 / 4,536	4 / 1.2	290
12,000 / 5,443	3.3 / 1	350

LINE PULL AND ROPE CAPACITY

LAYER OF ROPE	PULL BY LAYER LB / KG	TOTAL ROPE ON DRUM FT / M
1st	12,000 / 5,443	17.7 / 5.4
2nd	9,522 / 4,319	40 / 12.2
3rd	7,893 / 3,580	67.3 / 20.5
4th	6,737 / 3,055	82 / 25

DIMENSIONS

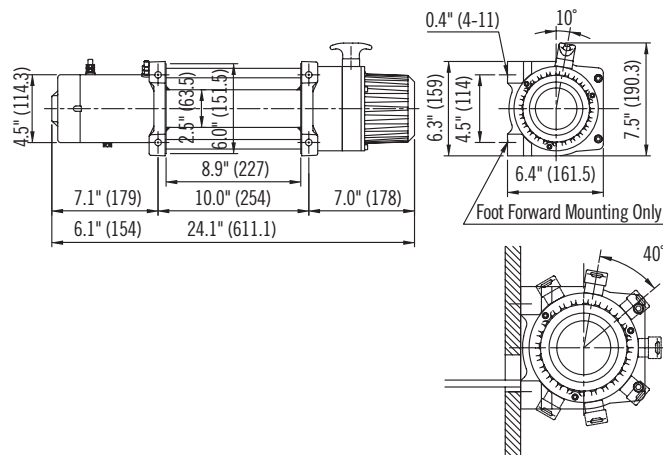

ELECTRIC WINCH PERFORMANCE DATA AND DIMENSIONS

DC12000 - 12,000 LBS.

PERFORMANCE DATA

LINE SPEED AND AMP. DRAW

LINE PULL LB / KG	SPEED FPM / MPM	12V AMPS
NO LOAD	27 / 8.3	60
4,000 / 1,814	8.6 / 2.6	200
8,000 / 3,629	5.8 / 1.7	310
10,000 / 4,536	4.4 / 1.4	370
12,000 / 5,443	4 / 1.2	440

LINE PULL AND ROPE CAPACITY

LAYER OF ROPE	PULL BY LAYER LB / KG	TOTAL ROPE ON DRUM FT / M
1st	12,000 / 5,443	21.5 / 6.6
2nd	10,060 / 4,563	47.2 / 14.4
3rd	8,659 / 3,928	77 / 23.5
4th	7,601 / 3,448	110.9 / 33.8
5th	6,774 / 3,073	125 / 58

DIMENSIONS

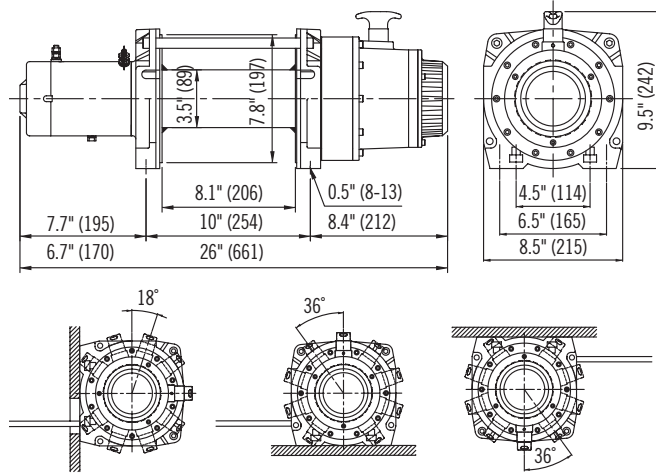

DC15000 - 15,000 LBS.

PERFORMANCE DATA

LINE SPEED AND AMP. DRAW

LINE PULL LB / KG	SPEED FPM / MPM	12V AMPS
NO LOAD	22 / 6.9	60
4,000 / 1,814	5.4 / 1.6	180
8,000 / 3,629	3.8 / 1.2	280
12,000 / 5,443	2.9 / 0.9	385
15,000 / 6,803	2.5 / 0.8	460

LINE PULL AND ROPE CAPACITY

LAYER OF ROPE	PULL BY LAYER LB / KG	TOTAL ROPE ON DRUM FT / M
1st	15,000 / 6,804	18.6 / 5.7
2nd	12,277 / 5,569	41.4 / 12.6
3rd	10,391 / 4,713	68.3 / 20.8
4th	9,007 / 4,086	89 / 27

DIMENSIONS

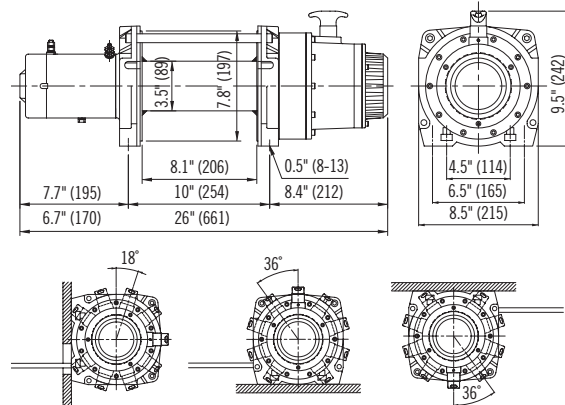

DC18000 - 18,000 LBS.

PERFORMANCE DATA

LINE SPEED AND AMP. DRAW

LINE PULL LB / KG	SPEED FPM / MPM	24V AMPS
NO LOAD	28.2 / 8.6	40
8,000 / 3,629	12.0 / 3.6	140
12,000 / 5,443	9.3 / 2.8	210
15,000 / 6,803	7.5 / 2.3	260
18,000 / 8,164	3.3 / 1	320

LINE PULL AND ROPE CAPACITY

LAYER OF ROPE	PULL BY LAYER LB / KG	TOTAL ROPE ON DRUM FT / M
1st	18,000 / 8,165	15.4 / 4.7
2nd	14,431 / 6,546	34.4 / 10.5
3rd	12,028 / 5,455	57.4 / 17.5
4th	10,311 / 4,677	82 / 25

DIMENSIONS

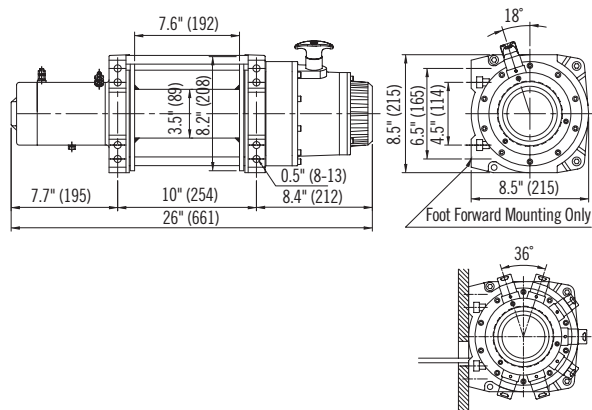

ELECTRIC WINCH PERFORMANCE DATA AND DIMENSIONS

DC2500 - 2,500 LBS.

>>> PERFORMANCE DATA

LINE SPEED AND AMP DRAW

LINE PULL LB / KG	LINE SPEED FPM / MPM	AMP DRAW
NO LOAD	16.4 / 5	30
1,000 / 454	11 / 3.5	80
2,000 / 907	7.5 / 2.3	150
2,500 / 1,134	4.2 / 1.3	200

LINE PULL AND ROPE CAPACITY

LAYER OF ROPE	PULL BY LAYER LB / KG	TOTAL ROPE ON DRUM FT / M
1st	2,500 / 1,134	10.2 / 3.1
2nd	2,149 / 975	22 / 6.7
3rd	1,885 / 855	35.5 / 10.8
4th	1,678 / 761	50 / 15.2

>>> DIMENSIONS

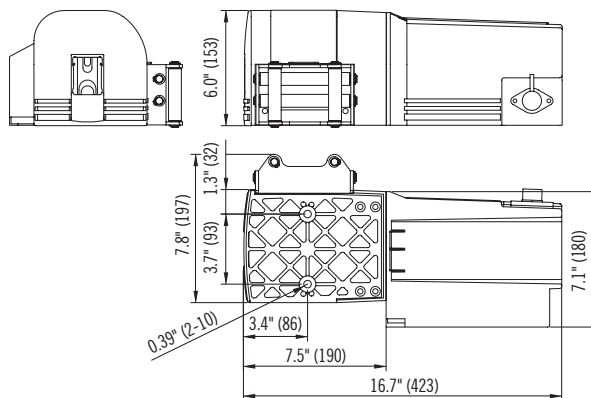

DC3500 - 3,500 LBS.

>>> PERFORMANCE DATA

LINE SPEED AND AMP DRAW

LINE PULL LB / KG	LINE SPEED FPM / MPM	AMP DRAW
NO LOAD	21.3 / 6.5	25
1,000 / 454	16.4 / 5	110
2,000 / 907	11.8 / 3.6	200
2,500 / 1,134	10.5 / 3.2	230
3,000 / 1,361	8.2 / 2.5	260
3,500 / 1,588	5.9 / 1.8	300

LINE PULL AND ROPE CAPACITY

LAYER OF ROPE	PULL BY LAYER LB / KG	TOTAL ROPE ON DRUM FT / M
1st	3,500 / 1,588	8.9 / 2.7
2nd	2,954 / 1,340	19.6 / 6
3rd	2,555 / 1,159	31.8 / 9.7
4th	2,251 / 1,021	45.7 / 13.9
5th	2,012 / 913	50 / 15.2

>>> DIMENSIONS

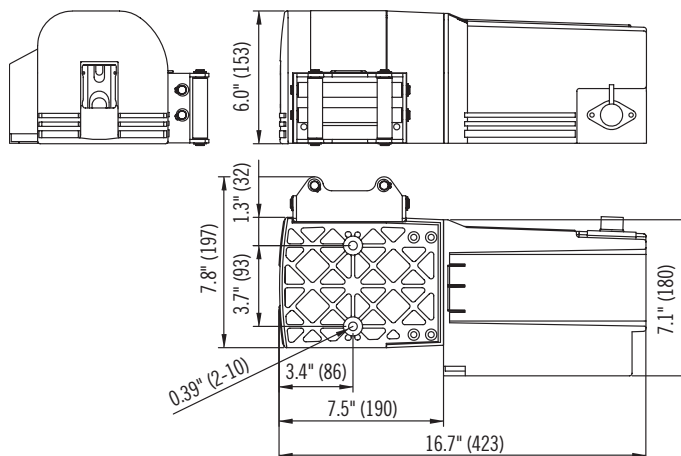

DC4500 - 4,500 LBS.

>>> PERFORMANCE DATA

LINE SPEED AND AMP DRAW

LINE PULL LB / KG	LINE SPEED FPM / MPM	AMP DRAW
NO LOAD	21.3 / 6.5	25
1,000 / 454	16.4 / 5	110
2,000 / 907	11.8 / 3.6	210
2,500 / 1,134	10.5 / 3.2	240
3,000 / 1,361	8.2 / 2.5	270
3,500 / 1,588	5.9 / 1.8	290
4,000 / 1,814	4.6 / 1.4	310
4,500 / 2,041	1.3 / 4	330

LINE PULL AND ROPE CAPACITY

LAYER OF ROPE	PULL BY LAYER LB / KG	TOTAL ROPE ON DRUM FT / M
1st	4,500 / 2,041	7.9 / 2.4
2nd	3,722 / 1,688	17.4 / 5.3
3rd	3,174 / 1,440	28.6 / 8.7
4th	2,766 / 1,255	41.4 / 12.6
5th	2,451 / 1,112	50 / 15.2

>>> DIMENSIONS

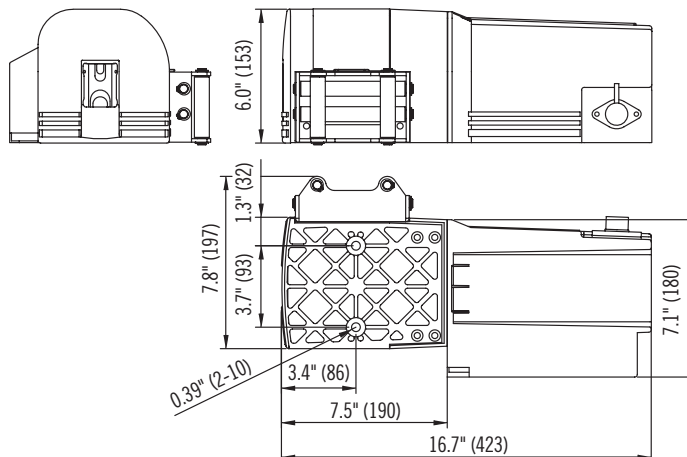

HYDRAULIC WINCH PERFORMANCE DATA AND DIMENSIONS

HW8000 - 8,000 LBS.

»»» PERFORMANCE DATA

LINE PULL AND ROPE CAPACITY			LINE SPEED
LAYER OF ROPE	PULL BY LAYER LB / KG	TOTAL ROPE ON DRUM FT / M	15.9 G / MIN (60 L / MIN) FPM / MPM
1st	8,000 / 3,630	25.6 / 7.8	49 / 15
2nd	6,669 / 3,025	56.1 / 17.1	59.7 / 18.2
3rd	5,717 / 2,593	91.9 / 28	69.8 / 21.2
4th	5,002 / 2,269	131 / 40	79.4 / 24.2

»»» DIMENSIONS

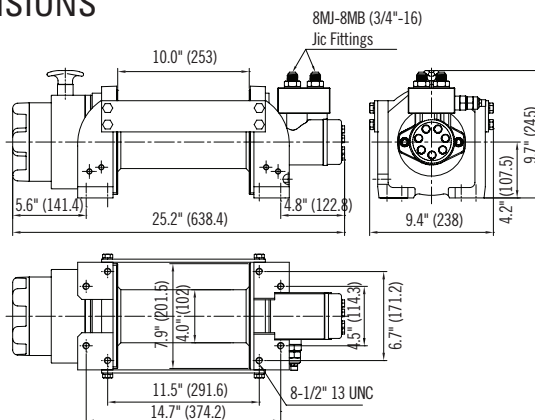

HW12000 - 12,000 LBS.

»»» PERFORMANCE DATA

LINE PULL AND ROPE CAPACITY			LINE SPEED
LAYER OF ROPE	PULL BY LAYER LB / KG	TOTAL ROPE ON DRUM FT / M	15.9 G / MIN (60 L / MIN) FPM / MPM
1st	12,000 / 5,440	23 / 7	36 / 11
2nd	10,075 / 4,570	50.9 / 15.5	43.3 / 13.2
3rd	8,684 / 3,939	25 / 82	51.2 / 15.6

»»» DIMENSIONS

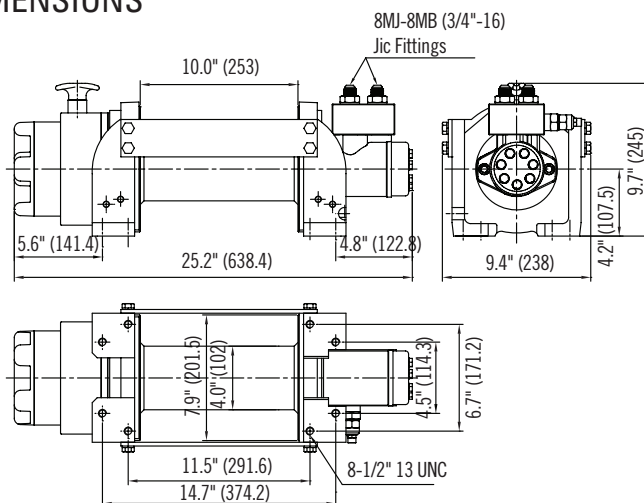

HW15000 - 15,000 LBS.

»»» PERFORMANCE DATA

LINE PULL AND ROPE CAPACITY			LINE SPEED
LAYER OF ROPE	PULL BY LAYER LB / KG	TOTAL ROPE ON DRUM FT / M	15.9 G / MIN (60 L / MIN) FPM / MPM
1st	15,000 / 6,800	23.3 / 7.1	30 / 9
2nd	12,273 / 5,567	51.5 / 15.7	35.8 / 10.9
3rd	10,390 / 4,713	25.9 / 85	42 / 12.8
4th	9,008 / 4,086	123.4 / 37.6	48.6 / 14.8
5th	7,950 / 3,606	165 / 50.3	55 / 16.8

»»» DIMENSIONS

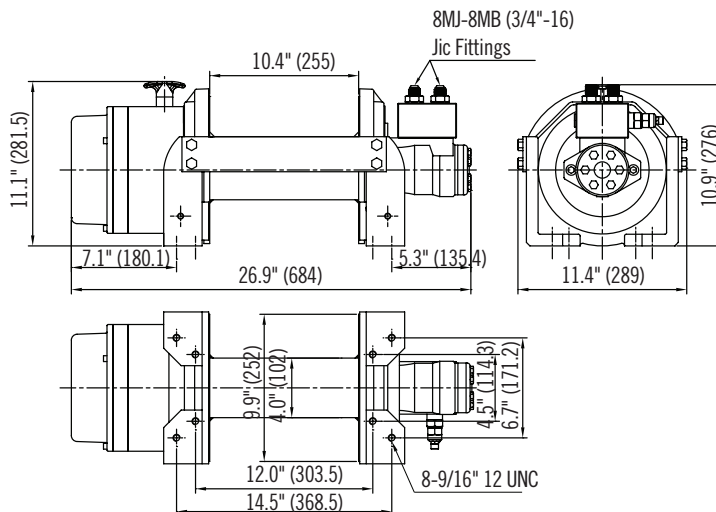

ELECTRIC HOIST PERFORMANCE DATA AND DIMENSIONS

DCH650 - 650 LBS.

>>> PERFORMANCE DATA

LINE SPEED AND AMP DRAW (first layer of wire rope on the drum)

1ST LAYER LINE PULL LB / KG	LINE SPEED FPM / MPM 12V	AMP DRAW 12V	% DUTY CYCLE MIN / 10 MIN
No Load	14.1 / 4.3	25	3.0
320 / 147	13.8 / 4.2	45	2.0
650 / 295	13.1 / 4.0	55	1.5

HOIST CAPACITY

ROPE LAYER	CAPACITY LB / KG	LINE SPEED FPM / MPM	LENGTH OF ROPE ON DRUM FT / M
1 ST	650 / 295	13.1 / 4.0	13.5 / 4.1
2 ND	586 / 266	14.8 / 4.5	28.5 / 8.7
3 RD	531 / 241	16 / 4.9	45.3 / 13.8
4 TH	487 / 221	17.7 / 5.4	60 / 18.3

>>> DIMENSIONS

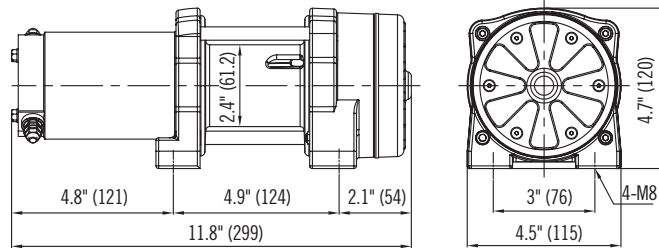

DCH800 - 800 LBS.

>>> PERFORMANCE DATA

LINE SPEED AND AMP DRAW (first layer of wire rope on the drum)

1ST LAYER LINE PULL LB / KG	LINE SPEED FPM / MPM 12V	AMP DRAW 12V	% DUTY CYCLE MIN / 10 MIN
No Load	11.8 / 3.6	20	3.0
400 / 184	11.2 / 3.4	40	2.0
800 / 362	10.5 / 3.2	55	1.5

ROPE LAYER	CAPACITY LB / KG	LINE SPEED FPM / MPM	LENGTH OF ROPE ON DRUM FT / M
1 ST	800 / 362	10.5 / 3.2	21.7 / 6.6
2 ND	721 / 327	11.8 / 3.6	45.9 / 14
3 RD	655 / 297	12.8 / 3.9	60 / 18.3

>>> DIMENSIONS

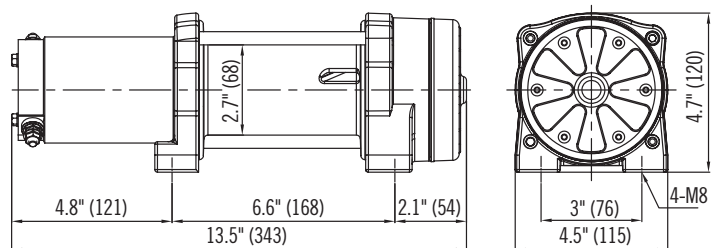

ELECTRIC HOIST PERFORMANCE DATA AND DIMENSIONS

DCH1200 - 1,200 LBS.

»»» PERFORMANCE DATA

LINE SPEED AND AMP DRAW (first layer of wire rope on the drum)

1ST LAYER LINE PULL LB / KG	LINE SPEED FPM / MPM 12V	AMP DRAW 12V	% DUTY CYCLE MIN / 10 MIN
No Load	24.3 / 7.4	30	2.5
300 / 136	22.6 / 6.9	55	2.3
600 / 272	21 / 6.4	75	2.0
900 / 408	19.4 / 5.9	95	1.8
1,200 / 544	18 / 5.5	130	1.5

»»» DIMENSIONS

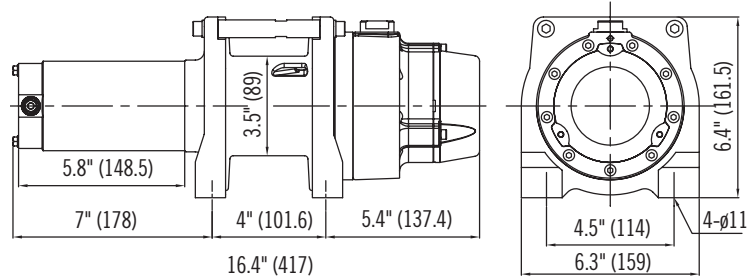

HOIST CAPACITY

ROPE LAYER	CAPACITY LB / KG	LINE SPEED FPM / MPM	LENGTH OF ROPE ON DRUM FT / M
1 ST	1,200 / 544	5.5 / 1.7	13.8 / 4.2
2 ND	1,089 / 494	19.9 / 6.1	28.9 / 8.8
3 RD	996 / 452	21.7 / 6.6	45.3 / 13.8
4 TH	917 / 416	23.6 / 7.2	60 / 18.3

Technical information is current as of the printing of this catalog. Contact technical service for periodic updates.



WARRANTIES AND PRODUCT INDEX

All products are covered by warranty for a minimum of one (1) year. Some products have longer warranty coverage periods. Please review the information on the following pages for warranty details across the product line.

Find products quickly by using our index. Look up product information, page numbers and fitments by part number. All part numbers are listed numerically.

DEALER INSTALLATION PROGRAM Q-2

WARRANTIES

Limited Lifetime Warranty Q-3
Limited Warranties Q-3

PRODUCT INDEX Q-44 - Q-64

PRODUCT APPLICATION INDEX

Class I Receivers Q-4 - Q-7
Class II Receivers Q-7 - Q-9
Class III Receivers Q-10 - Q-19
Class IV Receivers Q-10 - Q-19
Class V Receivers Q-19 - Q-21
Front Mounted Receivers Q-21 - Q-22

PRODUCT APPLICATION INDEX

Brake Control Harnesses Q-22 - Q-26
T-One® Connectors Q-26 - Q-33
Tow Harnesses Q-33 - Q-35
Fifth Wheel Harnesses Q-35 - Q-37
6-Way and 7-Way Connectors Q-37 - Q-38
Fifth Wheel Rail Kits Q-38 - Q-42
M5 Series Fifth Wheels Q-41
Elite™ Series Fifth Wheels Q-41
Elite™ Series Gooseneck Q-42
Under-Bed Gooseneck Q-42
Above-Bed Gooseneck Q-42 - Q-43
Truck Bed Racks Q-43



How would you like to reduce the cost of your hitch installation liability insurance and get **ADDITIONAL PROTECTION FREE?**



INSTALLED
Install Horizon Global branded applicable products properly, according to the instructions included.



INFORMED
Before installation begins, present the towing safety form to the customer and have them read and sign it.

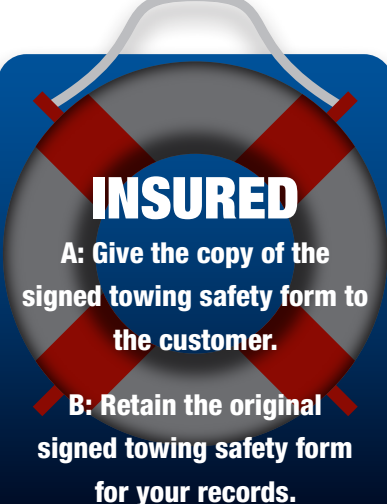

INSURED
A: Give the copy of the signed towing safety form to the customer.
B: Retain the original signed towing safety form for your records.

DEALER SUPPORT

In the interest of safe towing, Draw-Tite® and Reese® offer this Dealer Installation Indemnification Program. We're committed to designing and building the industry's highest quality trailer hitches and towing accessories. We also back our equipment with an extraordinary level of support for our customers. Once enrolled in the Dealer Installation Indemnification Program, when you sell and properly install complete Draw-Tite® or Reese® applicable products according to written instructions and provide your customers with the required information for safe and proper towing, you are indemnified on any claim over USD \$2,000 arising from your installation of Horizon Global branded products. *(For conditions and limitation see Dealer Agreement.)*

INDEPENDENT OF THIS AGREEMENT, THE HORIZON GLOBAL LIMITED LIFETIME WARRANTY REMAINS IN EFFECT WITH RESPECT TO PRODUCT CLAIMS.

To enroll in the program, contact your Sales Representative

DEALER BENEFITS

What you receive is the potential of significant cost savings by reducing your installation liability coverage for Horizon Global branded products. We design and build safety into everything we produce, so we have the confidence to back Horizon Global branded products with this comprehensive program. Therefore you'll be able to serve your customers with a new level of confidence, knowing Horizon Global backs your work. However, Horizon Global recommends you determine your base liability coverage requirements with your local insurance professional.

ELIGIBILITY

To qualify for the Dealer Installation Indemnification Program, you must be a qualified Draw-Tite® or Reese® Installer. If you install other manufacturers' products, you will need to maintain liability insurance to cover non Horizon Global branded products.

PROGRAM COST

There is no charge to the participating Dealer.

CLASS I RECEIVER HITCH INDEX

PC	PART NO.	YEARS	MAKE/MODEL	WGT LBS	IN
CLASS I: 1-1/4" HITCH					
36	24526f	92-09	Ford Crown Victoria	31	25
		79-82	Ford LTD		25
		83-86	Ford LTD Country Squire Wagon		25
		83-91	Ford LTD Crown Victoria		25
		83-91	Ford LTD Crown Victoria Wagon		25
		80-83	Lincoln Mark VI		25
		81-02	Lincoln Town Car		25
		87-91	Mercury Colony Park Wagon		25
		83-11	Mercury Grand Marquis		25
		83-86	Mercury Grand Marquis Colony Park Wagon		25
		03-04	Mercury Marauder		25
		79-82	Mercury Marquis Sedan		25
		79-82	Mercury Marquis Wagon		25
17	24534f	90-91	Lexus ES250 FWD	10	40
		87-91	Toyota Camry 4 Dr. Sedan		40
		87-91	Toyota Camry Wagon		40
36	24557f	87-95	Jeep Wrangler	21	30
		87-95	Jeep YJ (Canada Only)		30
33	24563f	92-01	Lexus ES300 4 Dr.	27	30
		92-96	Toyota Camry		30
25	24579	98-02	Chevrolet Prizm	20	30
		93-97	GEO Prizm		30
		93-02	Toyota Corolla Sedan		30
22	24589	94-01	Acura Integra	17	40
35	24594f	94-98	Volkswagen Jetta Jetta III	30	30
31	24606f	91-98	Toyota Tercel Sedan	19	30
36	24613f	03-05	Chevrolet Cavalier LS Sport	29	40
		95-02	Chevrolet Cavalier Z-24		40
		03-05	Chevrolet Cavalier Z-24 (Canada Only)		40
		00-02	Pontiac Sunfire		40
		95-99	Pontiac Sunfire GT		40
45	24616	94-97	Honda Accord	29	30
33	24620	91-92	Saturn SC 2 Dr. Coupe	25	40
		93-02	Saturn SC1 2 Dr. Coupe		40
		93-02	Saturn SC2 2 Dr. Coupe		40
		91-02	Saturn SL 4 Dr. Sedan		40
		91-02	Saturn SL1 4 Dr. Sedan		40
		91-02	Saturn SL2 4 Dr. Sedan		40
		93-99	Saturn SW1 Wagon		40
		93-01	Saturn SW2 Wagon		40
24	24622	98	Chevrolet Tracker	18	20
		89-97	GEO Tracker		20
		89-95	Suzuki Sidekick		20
		96-98	Suzuki Sidekick Except Sport Model		20
		96-98	Suzuki X-90		20
23	24628	95-00	Chevrolet Lumina	20	30
		95-99	Chevrolet Monte Carlo		30
27	24631	97-06	Jeep TJ (Canada Only)	19	15
		97-06	Jeep Wrangler		15
45	24639f	90-93	Honda Accord Sedan	26	20
27	24646f	96-00	Hyundai Elantra	13	30
34	24656	97-05	Chevrolet Malibu 4 Dr.	22	15
		97-99	Oldsmobile Cutlass 4 Dr., FWD		15
24	24659	97-05	Buick Century Sedan	13	30
		98-02	Oldsmobile Intrigue		30
		97-03	Pontiac Grand Prix SE Sedan		30
27	24660	97-04	Buick Regal (App. starts with 97-1/2)	13	20
		97-08	Pontiac Grand Prix		20
29	24673	99-04	Chevrolet Tracker	18	15
		99-05	Suzuki Grand Vitara		15
		99-04	Suzuki Vitara		15
		02-06	Suzuki XL-7		15
25	24675f	99-03	Mazda Protege	26	20
29	24677	97-01	Acura EL (Canada Only)	19	15
		92-00	Honda Civic		15
39	24679	98-01	Volkswagen Beetle	31	30
		02-10	Volkswagen Beetle Except Turbo S		30
		99-06	Volkswagen Golf		30
		07-10	Volkswagen Golf City (Canada Only)		30
25	24681	00-05	Chevrolet Impala	16	20
33	24682	03-07	Ford Focus Wagon (Built After 11/2002)	27	20
		00-02	Ford Focus Wagon (Built Before 11/2002)		20
14	24685f	01-02	Saturn L100	14	35
		01-02	Saturn L200		35
		01-02	Saturn L300		35
		00	Saturn LS		35

PC	PART NO.	YEARS	MAKE/MODEL	WGT LBS	IN
14	24685f	00	Saturn LS1	14	35
		00	Saturn LS2		35
		03	Saturn LW200 Wagon		35
		03	Saturn LW300 Wagon		35
34	24686	96-01	Infiniti I30	18	30
		02-04	Infiniti I35		30
		95-03	Nissan Maxima Sedan		30
29	24687	94-98	Ford Mustang	27	20
		99-04	Ford Mustang Except Cobra SVT		20
39	24690	93-01	Nissan Altima	22	20
24	24692	00-04	Ford Focus Sedan	15	20
		05-07	Ford Focus Sedan, Except w/Street Appearance Pkg.		20
		00-06	Ford Focus ZX3 3 Dr. Hatchback, Except SVT & w/Street Appearance Pkg.		20
		02-06	Ford Focus ZX5 5 Dr. Hatchback, Except SVT & w/Street Appearance Pkg.		20
20	24698	99-05	Volkswagen Passat 4 Dr. Sedan, Except 4 Motion & W8 Engine	19	40
		99-05	Volkswagen Passat Wagon, Except 4 Motion & W8 Engine		40
35	24699	86-03	Ford Taurus 4 Dr. Sedan	29	20
		96-99	Ford Taurus 4 Dr. Sedan, Except SHO		20
		86-03	Ford Taurus Wagon		20
		88-02	Lincoln Continental		20
		86-03	Mercury Sable Sedan		20
		86-03	Mercury Sable Wagon		20
42	24701f	00-05	Dodge Neon	30	20
		00-01	Plymouth Neon		20
33	24703	01-06	Hyundai Elantra	19	15
31	24704	96-05	Toyota RAV4	21	15
31	24706	01-05	Honda Civic	19	15
44	24709f	01-04	KIA Magentis (Canada Only)	18	15
		01-06	KIA Optima		15
25	24710	93-01	Subaru Impreza	20	30
		02-07	Subaru Impreza Except WRX STi		30
28	24711	01-06	Chrysler Sebring Convertible	20	15
31	24713f	02-05	Hyundai Sonata	21	15
36	24714f	02-03	Mazda Protege5	28	15
34	24715	97-04	Toyota Camry 4 Dr. Sedan	26	15
		99-03	Toyota Solara		15
20	24719	02-06	Acura RSX	12	30
		02-05	Honda Civic Si		30
19	24720	03-04	Honda Element	10	25
		05-11	Honda Element Except SC		25
27	24721f	97-05	Chevrolet Venture	20	30
		97-04	Oldsmobile Silhouette		30
		99-05	Pontiac Montana		30
		97-98	Pontiac Trans Sport		30
25	24726f	03-08	Hyundai Tiburon	26	45
33	24727f	02-05	KIA Rio	14	20
30	24732	03-06	Mitsubishi Outlander	22	40
31	24733	00-01	Chevrolet Cavalier	31	40
		03-05	Chevrolet Cavalier Except LS Sport		40
		95-02	Chevrolet Cavalier Except Z-24		40
		03-05	Pontiac Sunfire		40
		95-99	Pontiac Sunfire Except GT		40
31	24734	03-07	Saturn Ion Except Redline & w/2.4 Liter Engine	38	35
39	24735f	03-06	Subaru Baja	27	20
32	24736f	00-05	Hyundai Accent	19	20
35	24740	05-06	Nissan X-Trail (Canada Only)	24	45
20	24741	04-11	Chevrolet Aveo 5 Dr. Hatchback	13	30
		09	Pontiac G3 5 Dr.		30
		09	Pontiac G3 Wave 5 Dr. (Canada Only)		30
		05-07	Pontiac Wave 5 Dr. (Canada Only)		30
		05-07	Pontiac Wave5 (Canada Only)		30
		04-09	Suzuki Swift+ 5 Dr. (Canada Only)		30
31	24743f	05-09	KIA Spectra Except Spectra5	25	20
20	24745	05-10	Chevrolet Cobalt 2 Dr., Except SS	18	40
		05-10	Chevrolet Cobalt 4 Dr., Except SS		40
		07-09	Pontiac G5 Except GT		40
		05-06	Pontiac Pursuit 2 Dr. (Canada Only)		40
		05-06	Pontiac Pursuit 4 Dr. (Canada Only)		40
22	24747	05-09	Ford Mustang Except GT/GS (California Special)/Shelby GT/GT500	18	45
29	24748	07-09	Volkswagen Jetta City Sedan (Canada Only)	23	30
		99-05	Volkswagen Jetta Sedan, Except Gas Turbo & Wagon		30
31	24750	00-06	Nissan Sentra	26	20

CLASS I RECEIVER HITCH INDEX

PC	PART NO.	YEARS	MAKE/MODEL	WGT LBS	IN
24	24754	06-12	Mitsubishi Eclipse	13	30
18	24755	04-08	Acura TL	10	35
30	24756	08	Chevrolet Cobalt Sport 2 Dr.	40	25
		08	Chevrolet Cobalt Sport 4 Dr.	25	25
		05-10	Chevrolet Cobalt SS 2 Dr.	25	25
		05-10	Chevrolet Cobalt SS 4 Dr.	25	25
		06-11	Chevrolet HHR	25	25
		08-10	Chevrolet HHR SS	35	35
		07-09	Pontiac G5 GT	25	25
		05-07	Saturn Ion 3 w/2.4 Liter Engine	25	25
		04-06	Saturn Ion Red Line	25	25
24	24757	06-10	Hyundai Sonata	21	20
31	24759	01-10	Chrysler PT Cruiser	19	30
		05-09	Chrysler PT Cruiser Convertible	30	30
32	24760	06-11	Hyundai Accent 4 Dr. Sedan	20	20
		06-11	KIA Rio 4 Dr. Sedan	20	20
27	24763	06-15	Honda Civic 2 Dr. Coupe, Except Si	22	30
		06-15	Honda Civic 4 Dr. Sedan, Except Hybrid & Si	30	30
		06-15	Honda Civic Hybrid	35	35
		06-15	Honda Civic Hybrid	30	30
		06-11	Honda Civic Si, 2 Dr. Coupe	30	30
		06-11	Honda Civic Si, 4 Dr. Sedan	30	30
24	24764	06-13	Suzuki Grand Vitara Except 3 Dr Hatchback	21	20
33	24767	03-07	Cadillac CTS	27	45
		08-13	Cadillac CTS 4 Dr. Sedan	45	45
		04-07	Cadillac CTS V	45	45
		09-13	Cadillac CTS V 4 Dr. Sedan	45	45
		05-11	Cadillac STS	45	45
25	24768	06-08	Acura TSX 4 Dr. Sedan	28	40
23	24769	07	Dodge Caliber	19	15
		08-12	Dodge Caliber Except SRT-4	15	15
32	24771	06-11	Hyundai Azera	30	20
27	24772	02-06	Honda CR-V	21	20
20	24773	06-10	Mazda 5	17	25
35	24775	06-09	Ford Fusion	18	45
		07-09	Lincoln MKZ	45	45
		06	Lincoln Zephyr	45	45
		03-08	Mazda 6 4 Dr. Sedan	45	45
		04-08	Mazda 6 5 Dr. Hatchback	45	45
		06-09	Mercury Milan	45	45
18	24776	07-08	Honda Fit	18	25
29	24778	06-10	KIA Magentis (Canada Only)	19	20
		09-10	KIA Optima	20	20
		06-08	KIA Optima (App. starts with 2006-1/2)	20	20
27	24781	04-11	Volvo S40 Sedan (App. starts with 2004-1/2)	20	25
		05-10	Volvo V50 Wagon, Except T5 R-Design	25	25
16	24785	04-07	Mazda 6 Sport Wagon	19	25
31	24787	03-07	Honda Accord Coupe	17	25
		03-07	Honda Accord Sedan	25	25
30	24788	02-06	Nissan Altima	26	30
		04-08	Nissan Maxima	30	30
18	24790	97-01	Honda CR-V	16	20
18	24791	01-03	Acura CL 3.2	18	15
		99-03	Acura TL 3.2	15	15
		98-02	Honda Accord Sedan	15	15
12	24792	07-11	Honda CR-V	17	20
22	24794	07-12	Nissan Sentra	17	30
28	24795	07-11	Hyundai Accent 3 Dr. Hatchback	21	25
		07-10	Hyundai Elantra 4 Dr. Sedan	25	25
		06-11	KIA Rio 5 Dr. Hatchback	25	25
15	24796	07-19	Nissan Altima Sedan	19	45
		09-19	Nissan Maxima	45	45
27	24797	07-10	KIA Rondo	18	30
		11-12	KIA Rondo (Canada Only)	30	30
35	24798	07-11	Nissan Versa 4 Dr. Sedan	25	25
		07-12	Nissan Versa 5 Dr. Hatchback	25	25
28	24801	08-13	Nissan Altima Coupe, Except SR Models	17	30
33	24805	08-11	Ford Focus	23	30
28	24807	09-13	Subaru Forester	29	35
		08-11	Subaru Impreza 4 Dr. Sedan	35	35
24	24808	04-09	Toyota Prius	23	30
34	24809	08-09	Saturn Astra Hatchback	24	25
23	24810	06-11	Chevrolet Aveo 4 Dr. Sedan	19	20
28	24811	08-10	Volvo C30	26	45
15	24812	03-08	Pontiac Vibe	21	15
		09-10	Pontiac Vibe Except GT	15	15
		03-13	Toyota Matrix	15	15

PC	PART NO.	YEARS	MAKE/MODEL	WGT LBS	IN
15	24812	14	Toyota Matrix (Canada Only)	21	15
33	24813	00-05	Toyota Echo Except Hatchback	27	15
22	24814	03-13	Toyota Corolla	20	20
13	24815	11-13	Scion tC Except Release Series	18	15
		08-13	Scion xB Except Release Series	15	15
27	24816	04-09	Mazda 3 4 Dr. Sedan, Except w/Grand Touring LED Taillights	20	35
		06-09	Mazda 3 4 Dr. Sedan, w/Grand Touring LED Taillights	35	35
		04-09	Mazda 3 5 Dr. Hatchback, Except w/Grand Touring LED Taillights	35	35
		06-09	Mazda 3 5 Dr. Hatchback, w/Grand Touring LED Taillights	35	35
18	24817	07-11	Suzuki SX4 Crossover	20	40
11	24819	07-11	Toyota Yaris 3 Dr. Liftback	14	20
		07-11	Toyota Yaris 4 Dr. Sedan	20	20
		09-11	Toyota Yaris 5 Dr. Liftback	20	20
31	24821	08-09	Pontiac G8	33	45
11	24822	96-00	Honda Civic 3 Dr. Hatchback	7	20
25	24824	07-13	Volkswagen Eos	29	40
19	24825	10-13	Volkswagen Golf 2 Dr. Hatchback, Except R	23	15
		10-14	Volkswagen Golf 4 Dr. Hatchback, Except R	15	15
		10-13	Volkswagen Golf Hatchback (Canada Only), Except R	15	15
		06-09	Volkswagen GTI 2 Dr. Hatchback	15	15
		07-09	Volkswagen GTI 4 Dr. Hatchback	15	15
		06-09	Volkswagen Rabbit	15	15
21	24826	09-13	Honda Fit	27	25
11	24827	05-10	Scion tC	14	30
14	24828	08-10	Scion xD	19	20
29	24830	09-16	Audi A4 4 Dr. Sedan	25	25
11	24831	07-08	Infiniti G35 4 Dr. Sedan	16	45
		09-13	Infiniti G37 4 Dr. Sedan	45	45
25	24832	09-13	Mazda 6 4 Dr. Sedan	30	30
21	24833	06-09	Pontiac Solstice	26	40
		06-09	Pontiac Solstice	35	35
		07-09	Pontiac Solstice GXP	35	35
		07-09	Pontiac Solstice GXP	40	40
		07-09	Saturn Sky	35	35
19	24835	07-12	Mitsubishi Galant	16	30
25	24836	05-11	Audi A6 4 Dr. Sedan	16	25
		06-10	Audi A6 Quattro Avant Wagon	25	25
13	24839	10-13	KIA Soul Except w/LED Taillights	20	40
		10-13	KIA Soul w/LED Taillights	40	40
23	24840	10	Ford Mustang Except GT/GS (California Special)/Shelby GT/GT500	27	45
25	24842	10-13	Mazda 3 4 Dr. Sedan, Except w/Grand Touring LED Taillights	25	20
		10-13	Mazda 3 4 Dr. Sedan, w/Grand Touring LED Taillights	20	20
20	24843	10-13	Mazda 3 5 Dr. Hatchback, Except w/Grand Touring LED Taillights	17	15
		10-13	Mazda 3 5 Dr. Hatchback, w/Grand Touring LED Taillights	15	15
14	24844	09-12	Hyundai Elantra Touring, 5 Dr.	21	25
20	24845	09-13	Nissan Cube	27	45
27	24846	10-13	KIA Forte 4 Dr. Sedan	24	20
18	24847	10-15	Toyota Prius Except w/Plug-In Model	18	25
		12-17	Toyota Prius V	25	25
22	24848	09-17	Volkswagen CC Except 4 Motion	18	35
		06-10	Volkswagen Passat 4 Dr. Sedan, Except 4 Motion	35	35
		07-10	Volkswagen Passat Wagon, Except 4 Motion	35	35
30	24850	10-15	Chevrolet Camaro Except Convertible & w/Dealer Installed Ground Effects	21	15
31	24852	10-11	Honda Accord Crosstour	26	40
		12-15	Honda Crosstour	40	40
25	24854	10-13	Acura ZDX	19	25
25	24855	11-19	Ford Fiesta 5 Dr. Hatchback	26	30
37	24856	11-13	Ford Fiesta 4 Dr. Sedan	21	15
43	24857	07-11	BMW 328i Sedan	29	45
		07-11	BMW 328i xDrive Sedan	45	45
		07-08	BMW 328xi Sedan	45	45
23	24860	10-12	Lexus HS250h Hybrid	20	25
27	24861	06-11	Acura CSX (Canada Only)	21	30
		13-19	Acura ILX Except Hybrid	35	35
24	24863	11-14	Ford Mustang V6 Models	19	40
		11-14	Ford Mustang V8 Models	40	40
25	24865	10-12	Ford Fusion	28	20

CLASS I RECEIVER HITCH INDEX

PC	PART NO.	YEARS	MAKE/MODEL	WGT LBS	IN
25	24865	10-12	Lincoln MKZ	28	20
		10-11	Mercury Milan		20
23	24866	10-14	Volkswagen Golf Wagon (Canada Only)	25	40
		05-14	Volkswagen Jetta 4 Dr. Sedan		40
		09-14	Volkswagen Jetta SportWagon		40
27	24867	11-17	Nissan JUKE AWD, Except Nismo & Nismo RS	23	40
28	24869	11-14	Mazda 2	27	30
50	24870	05-12	Toyota Avalon	32	40
28	24871	11-14	Chrysler 200 4 Dr. Sedan	25	15
		11-14	Chrysler 200 Convertible		15
		07-10	Chrysler Sebring Convertible		15
		07-10	Chrysler Sebring Except Convertible		15
		08-14	Dodge Avenger		15
18	24872	12-14	Ford Focus 5 Dr. Hatchback, Except ST w/Center Exhaust	23	25
		15-18	Ford Focus 5 Dr. Hatchback, Except ST w/Center Exhaust Models & RS		25
		12-18	Ford Focus Sedan		25
28	24873	12-19	FIAT 500 Except Abarth	20	30
24	24874	12-17	Mazda 5	26	25
20	24876	12-17	Chevrolet Sonic 4 Dr. Sedan	20	20
27	24877	12-13	Volkswagen Beetle Except Convertible & Gas Turbo	25	20
25	24878	12-19	Chevrolet Sonic 5 Dr. Hatchback	28	20
29	24879	12-13	Volkswagen Beetle Gas Turbo, Except Convertible	29	30
34	24880	17-19	Volkswagen Passat	30	30
		12-15	Volkswagen Passat 4 Dr. Sedan		30
		16	Volkswagen Passat Except SE & SEL		30
	16	Volkswagen Passat SE & SEL Only		30	
27	24881	12-13	Chevrolet Orlando (Canada Only)	35	35
18	24882	12-17	Buick Verano Except Turbo or w/Dual Exhaust	24	40
		11-15	Chevrolet Cruze		15
		16	Chevrolet Cruze Limited Only (Old Body Style)		15
28	24883	12-16	KIA Rio 5 Dr. Hatchback	23	30
30	24884	12-17	Hyundai Accent 4 Dr. Sedan	26	15
		12-17	Hyundai Accent 5 Dr. Hatchback		15
		12-17	KIA Rio 4 Dr. Sedan, Except S		15
		12-17	KIA Rio 4 Dr. Sedan, Except S		15
27	24885	08-17	Mitsubishi Lancer 4 Dr. Sedan, Except Evolution, Ralliart & w/Dual Exhaust	20	25
		10-14	Mitsubishi Lancer 5 Dr. Hatchback, Except Ralliart & w/Dual Exhaust		25
19	24886	08-16	Subaru Impreza 5 Dr. Wagon, Except WRX STi & w/Quad Exhaust Outlets	23	45
		13-15	Subaru XV Crosstrek Except Hybrid		45
		13-15	Subaru XV Crosstrek Hybrid		45
29	24887	12-17	Nissan Versa 4 Dr. Sedan	28	30
25	24888	12-16	Subaru Impreza 4 Dr. Sedan, Except WRX & WRX STi	31	30
23	24889	12-17	Toyota Prius C	14	20
30	24890	13-16	Dodge Dart	28	20
30	24892	11-17	Nissan JUKE FWD, Except Nismo & Nismo RS	25	25
24	24893	13-15	Chevrolet Spark Except w/Ground Effects	10	25
24	24894	13-15	Chevrolet Spark LT w/Ground Effects	20	25
29	24896	13-18	Ford C-MAX	19	25
19	24897	13-19	Ford Fusion Except Sport	23	20
		13-19	Lincoln MKZ Except 3.0 Liter Engine		20
19	24899	09-14	Acura TL	14	45
		09-14	Acura TSX 4 Dr. Sedan		45
		08-16	Honda Accord Coupe		30
		08-16	Honda Accord Coupe		45
		13-15	Honda Accord Coupe, Except w/LED Taillights		30
		13-15	Honda Accord Coupe, w/LED Taillights		45
		08-17	Honda Accord Sedan		30
		13-15	Honda Accord Sedan, Except w/LED Taillights		45
		13-15	Honda Accord Sedan, w/LED Taillights		45
		13-15	Honda Accord Sedan, w/LED Taillights		45
		13-15	Honda Accord Sedan, w/LED Taillights		45
17	24902	13-14	Hyundai Elantra 2 Dr. Coupe	24	25
		11-16	Hyundai Elantra 4 Dr. Sedan		25
23	24903	14-18	KIA Forte 4 Dr. Sedan	14	20
28	24904	10-14	Volkswagen GTI Hatchback	14	40
		10-12	Volkswagen GTI Hatchback (Canada Only)		40
25	24905	13-17	Hyundai Elantra GT Except for Korean Manufactured Vehicles	18	25
		13-19	Nissan Sentra Except SR		21
25	24908	14-19	Mazda 6 4 Dr. Sedan	28	30
15	24909	14-17	Nissan Versa Note	20	30
31	24910	14-19	Ford Fiesta 4 Dr. Sedan	25	15
14	24911	07-14	Toyota Yaris 3 Dr. Liftback	18	20
		07-14	Toyota Yaris 5 Dr. Liftback, Except SE		20
25	24912	14-17	Mazda 3 4 Dr. Sedan	19	15

PC	PART NO.	YEARS	MAKE/MODEL	WGT LBS	IN
23	24913	03-13	Toyota Corolla	22	20
		14-19	Toyota Corolla Except Hatchback		20
24	24914	14-18	Mazda 3 5 Dr. Hatchback	25	30
19	24915	14-19	KIA Soul Except w/LED Taillights	21	40
		14-19	KIA Soul w/LED Taillights		40
27	24916	14-15	Mitsubishi Mirage	20	20
		17	Mitsubishi Mirage Except Mirage G4		20
27	24919	15-17	Chrysler 200 4 Dr. Sedan	22	20
16	24920	15-19	Honda Fit	27	25
13	24921	14-16	Scion tC Except Dual Exhaust	19	15
28	24922	14-19	Volkswagen Beetle Except R-Line & GSR	25	20
25	24923	14-15	Lexus IS250 Except Convertible	29	35
		14-19	Lexus IS350		35
29	24924	13-19	Cadillac ATS Except ATS-V	24	30
25	24925	15-17	Volkswagen Golf	15	60
		16-17	Volkswagen GTI		60
33	24926	15-18	Volkswagen Jetta 4 Dr. Sedan, Except Hybrid & TDI	28	40
30	24927	14-15	Cadillac CTS 4 Dr. Sedan	17	60
		16-19	Cadillac CTS 4 Dr. Sedan, Except CTS-V		60
43	24928	15-19	Ford Mustang	36	30
16	24929	15-19	Toyota Yaris Except SE	19	25
27	24930	15-19	Audi A3 Except Sportback e-tron	22	20
27	24931	14-17	Infiniti Q50	25	40
18	24932	16-19	Honda HR-V	18	35
33	24933	16-19	Mazda CX-3	30	25
37	24934	11-16	MINI Cooper Countryman Except John Cooper Works Model	34	70
30	24935	13-16	Scion FR-S	25	75
		13-19	Subaru BRZ		75
	17-19	Toyota 86		75	
32	24936	15-16	BMW 528i	25	50
		15-16	BMW 528i xDrive		50
		15-16	BMW 535d		50
		15-16	BMW 535d xDrive		50
		15-16	BMW 535i		50
		15-17	BMW 535i GT		50
		15-17	BMW 535i GT xDrive		50
		15-16	BMW 535i xDrive		50
		15-16	BMW 550i		50
		15	BMW 550i GT		50
		15-16	BMW 550i GT xDrive		50
	15-16	BMW 550i xDrive		50	
24	24937	16	Honda Civic Sedan	24	65
23	24938	16-19	Chevrolet Camaro	22	50
15	24939	17	Hyundai Elantra 4 Dr. Except Limited & Sport Models	21	50
		17	Hyundai Elantra 4 Dr. Limited Models Except Sport		50
18	24941	16-19	Chevrolet Spark	21	45
29	24942	15-19	Acura TLX	16	60
18	24943	16-19	Chevrolet Cruze (New Body Style)	21	80
16	24944	16-19	Toyota Prius Except Prius Prime	20	45
24	24945	12-17	BMW 320i	21	50
		12-17	BMW 320i xDrive		50
		12-16	BMW 328d		50
		12-16	BMW 328d xDrive Sedan		50
		12-16	BMW 328d xDrive Sports Wagon		50
		12-16	BMW 328i Sedan		50
		12-14	BMW 335i xDrive Sedan		50
24	24946	16	Honda Civic Coupe	24	65
		16	Honda Civic Sedan		65
16	24947	16-19	Chevrolet Volt	21	60
32	24948	16	Scion iA	26	30
		17-18	Toyota Yaris iA		30
19	24949	17-19	Volkswagen Golf Alltrack	20	60
		15-17	Volkswagen Golf SportWagen		60
23	24950	09-19	Audi A4 4 Dr. Sedan	28	25
18	24951	17-19	Chevrolet Cruze Hatchback	21	60
20	24952	16	Scion iM	24	40
		17	Toyota Corolla iM		40
27	24953	15-19	Mercedes-Benz C300 Sedan, Except Models w/Sport Package	18	75
24	24954	16-19	Honda Civic Coupe, Except Models w/Center Exhaust	19	65
		16-19	Honda Civic Hatchback, Except Models w/Center Exhaust		65
		16-19	Honda Civic Sedan, Except Models w/Center Exhaust		65
28	24955	16-17	Buick Cascada	33	15
20	24956	17-19	Chevrolet Bolt EV	23	20

CLASS II RECEIVER HITCH INDEX

PC	PART NO.	YEARS	MAKE/MODEL	WGT LBS	IN
37	24958	12-16	Tesla S	22	150
19	24959	08-19	Subaru Impreza 5 Dr. Wagon, Except WRX STI & w/Quad Exhaust Outlets	23	20
		08-19	Subaru Impreza 5 Dr. Wagon, Except WRX STI & w/Quad Exhaust Outlets		45
		13-15	Subaru XV Crosstrek Except Hybrid		30
		13-15	Subaru XV Crosstrek Hybrid		30
25	24960	12-19	Subaru Impreza 4 Dr. Sedan, Except WRX & WRX STI	31	40
19	24961	11-19	Ford Fiesta 5 Dr. Hatchback	26	30
20	24962	18	Toyota C-HR	28	60
23	24963	17	Hyundai Ioniq Hybrid	26	30
23	24964	18-20	Hyundai Elantra Except GT & Sport	30	40
22	24965	11-19	Hyundai Sonata Except Hybrid	35	40
		11-16	Hyundai Sonata Hybrid		40
		11-19	KIA Optima		40
16	24966	16-19	Toyota Prius Except Prius Prime	21	45
		17-18	Toyota Prius Prime		45
21	24967	10-15	Toyota Prius Except w/Plug-In Model	21	40
		12-15	Toyota Prius Plug-In		40
		12-17	Toyota Prius V		40
20	24968	15-18	Subaru WRX STI	31	60
28	24969	14-18	FIAT 500L	25	45
25	24970	18	Hyundai Elantra GT Except Sport	42	45
24	24971	12-19	Toyota Prius C	28	20
19	24972	18-19	Honda Accord	19	60
41	24974	18	KIA Stinger	42	90
30	24975	15-18	Volkswagen Golf R	20	75
41	24976	18	Hyundai Kona	30	35
33	24977	16-18	Ford Focus RS	42	60
37	24978	19	Volkswagen Jetta	20	80
30	24979	18-19	Volkswagen GTI	17	80
29	24980	18-19	Nissan Kicks	28	45
24	24982	19	Mazda 3 Sedan	24	40
23	24983	20	Toyota Corolla Sedan	28	40
17	24984	19	Mazda 3 Hatchback	19	40
22	24985	20	KIA Soul	22	30
23	24990	19-20	KIA Forte Sedan	22	40
22	28501	04-06	Scion xB	21	25
CLASS II: 1-1/4" HITCH					
47	36105t	77-83	Buick Estate Wagon	35	30
		77-90	Buick LeSabre Wagon		30
		91-95	Buick Roadmaster Estate Wagon		30
		77-96	Chevrolet Caprice Wagon		30
		77-92	Oldsmobile Custom Cruiser Wagon		30
		83-86	Pontiac Parisienne Wagon		30
		87-89	Pontiac Safari Wagon		30
17	36114	19-20	Acura RDX With +12V Power Provision	23	30
		19-20	Acura RDX Without +12V Power Provision		25
39	36116	92-09	Ford Crown Victoria	33	30
		79-82	Ford LTD		30
		83-86	Ford LTD Country Squire Wagon		30
		83-91	Ford LTD Crown Victoria		30
		83-91	Ford LTD Crown Victoria Wagon		30
		80-83	Lincoln Mark VI		30
		81-11	Lincoln Town Car		30
		87-91	Mercury Colony Park Wagon		30
		83-11	Mercury Grand Marquis		30
		83-86	Mercury Grand Marquis Colony Park Wagon		30
		03-04	Mercury Marauder		30
		79-82	Mercury Marquis Sedan		30
		79-82	Mercury Marquis Wagon		30
43	36124t	88-94	Buick Regal 2 Dr.	38	60
		91-94	Buick Regal 4 Dr., Except GS/Limited		60
		90-94	Chevrolet Lumina Except Z-34		60
		88-93	Oldsmobile Cutlass Supreme 2 Dr. FWD		60
		92-97	Oldsmobile Cutlass Supreme 4 Dr. FWD		60
		88-90	Pontiac Grand Prix Except SE & Turbo		60
		91-93	Pontiac Grand Prix Except Turbo		60
47	36136	90-93	Chrysler Imperial	45	40
		87-95	Chrysler LeBaron 2 Dr. Coupe		40
		90-94	Chrysler LeBaron 4 Dr.		40
		86-88	Chrysler New Yorker		40
		90-93	Chrysler New Yorker Fifth Ave. FWD		40
		88-90	Chrysler New Yorker FWD Sedan		40
		90-93	Chrysler New Yorker Salon		40
		88-93	Dodge Dynasty		40
		89-95	Dodge Spirit		40

PC	PART NO.	YEARS	MAKE/MODEL	WGT LBS	IN
47	36136	89-95	Plymouth Acclaim	45	40
43	36170t	93-97	Chrysler Concorde	40	40
		93-97	Chrysler Intrepid (Canada Only)		40
		94-97	Chrysler LHS		40
		94-96	Chrysler New Yorker		40
		93-97	Dodge Intrepid		40
		93-97	Eagle Vision		40
60	36173t	89-93	Cadillac DeVille	43	40
		89-93	Cadillac Fleetwood Coupe & Sedan, FWD		40
41	36179	96-97	Ford Thunderbird	25	40
		89-95	Ford Thunderbird Except SC		40
		93-98	Lincoln Mark VIII		40
		89-97	Mercury Cougar		40
44	36183t	84-90	Dodge Caravan	30	30
		91-93	Dodge Caravan C/V Long Wheelbase, 2 WD		30
		94-95	Dodge Caravan C/V Long Wheelbase, 2 WD, Except LE		30
		91-95	Dodge Caravan C/V Short Wheelbase		30
		91-95	Dodge Caravan Short Wheelbase		30
		87-93	Dodge Grand Caravan Long Wheelbase, 2 WD		30
		94-95	Dodge Grand Caravan Long Wheelbase, 2 WD, Except LE		30
		84-88	Dodge Mini Ram		30
		87-90	Plymouth Grand Voyager		30
		91-95	Plymouth Grand Voyager Long Wheelbase, 2 WD		30
		84-90	Plymouth Voyager		30
		91-95	Plymouth Voyager Short Wheelbase		30
43	36184t	94-96	Chevrolet Lumina APV	32	40
		94-96	Pontiac Trans Sport		40
51	36185t	94-96	Cadillac DeVille	37	40
41	36188t	85-96	Oldsmobile Cutlass Ciera FWD	32	40
		85-91	Pontiac 6000 Except AWD		40
30	36189	95-98	Ford Windstar	25	30
		03	Ford Windstar (Built After 11/2002)		30
		99-03	Ford Windstar (Built Before 11/2002)		30
48	36193t	95-00	Chevrolet Lumina	40	60
		95-99	Chevrolet Monte Carlo		60
33	36197	90-05	Chevrolet Astro Extended Body	38	30
		85-94	Chevrolet Astro Standard Body		30
		90-05	GMC Safari Extended Body		30
		85-94	GMC Safari Standard Body		30
34	36198	90-05	Chevrolet Astro Extended Body	32	30
		85-94	Chevrolet Astro Standard Body		30
		90-05	GMC Safari Extended Body		30
		85-94	GMC Safari Standard Body		30
35	36204	95-98	Honda Odyssey	28	30
		96-99	Isuzu Oasis		30
31	36206	96-14	Chevrolet Express 1500	25	15
		96-19	Chevrolet Express 2500		15
		96-19	Chevrolet Express 3500		15
		96-14	GMC Savana 1500		15
		96-17	GMC Savana 2500		15
		96-17	GMC Savana 3500		15
50	36211t	96-99	Oldsmobile 88	34	30
		96-99	Oldsmobile LSS		30
		97-98	Oldsmobile Regency		30
		96-99	Pontiac Bonneville Except SLE/SSE/SSEi		30
43	36216t	92-99	Buick LeSabre FWD	25	40
		92-95	Oldsmobile 88		40
		92-95	Pontiac Bonneville Except SSE & SSEi		40
39	36222t	97-03	Infiniti QX4	28	20
		96-04	Nissan Pathfinder		20
41	36226t	96-04	Acura RL 3.5	28	30
41	36233	97-05	Chevrolet Malibu 4 Dr.	34	20
		97-99	Oldsmobile Cutlass 4 Dr., FWD		20
48	36234	90-99	Subaru Legacy Coupe & Sedan	36	25
		90-95	Subaru Legacy Wagon		20
		96-99	Subaru Legacy Wagon, Except Outback		20
		96-99	Subaru Legacy Wagon, Outback		20
29	36238	97-06	Jeep TJ (Canada Only)	24	15
		97-06	Jeep Wrangler		15
51	36241	97-04	Buick Regal (App. starts with 97-1/2)	29	35
		97-08	Pontiac Grand Prix		35
36	36243	98-04	Cadillac Seville	24	35
32	36244	95-05	Chevrolet Blazer Downsize	25	15
		99-01	Chevrolet Blazer Trailblazer		15
		95-05	GMC Jimmy Downsize		15
		96-01	Oldsmobile Bravada		15

CLASS II RECEIVER HITCH INDEX

PC	PART NO.	YEARS	MAKE/MODEL	WGT LBS	IN
47	36245	97-04	Buick Park Avenue	35	40
32	36246	91-00	Ford Explorer	27	15
		01-03	Ford Explorer 2 Dr. Sport		15
		01	Ford Explorer 4 Dr.		15
		91-94	Mazda Navajo		15
		97-01	Mercury Mountaineer		15
28	36247	98-01	Honda Passport w/Door Mounted Spare	26	15
		98-00	Isuzu Amigo w/Door Mounted Spare		15
		01-03	Isuzu Rodeo Sport 2 Dr., w/Door Mounted Spare		15
		98-01	Isuzu Rodeo w/Door Mounted Spare		15
34	36248	98-04	Chevrolet S10	25	35
		83-97	Chevrolet S10 w/Standard Bed & Step Bumper		35
		83-90	GMC S15 w/Standard Bed & Step Bumper		35
		98-04	GMC Sonoma		35
		96-00	Isuzu Hombre w/Step Bumper		35
35	36252	86-03	Ford Taurus 4 Dr. Sedan	34	20
		96-99	Ford Taurus 4 Dr. Sedan, Except SHO		20
		96-99	Ford Taurus SHO		20
		86-03	Ford Taurus Wagon		20
		88-02	Lincoln Continental		20
		86-03	Mercury Sable Sedan		20
		86-03	Mercury Sable Wagon		20
34	36260	84-01	Jeep Cherokee	23	30
		84-90	Jeep Wagoneer		30
41	36261	93-98	Mercury Villager	27	15
		93-98	Nissan Quest		15
29	36262	93-97	Volvo 850 Sedan	20	20
		94-97	Volvo 850 Wagon		20
		98-04	Volvo C70 Convertible		20
		98-02	Volvo C70 Coupe		20
		98-00	Volvo S70 Sedan		20
		98-00	Volvo V70 Wagon		20
33	36266	95-02	KIA Sportage	25	20
50	36267	97-99	Cadillac DeVille	38	20
37	36268	98-04	Chrysler Intrepid (Canada Only)	24	30
		98-04	Dodge Intrepid		30
42	36270	98-01	Chrysler Concorde	33	35
39	36271	99-03	Lexus RX300	34	15
		01-03	Toyota Highlander		15
34	36274	02-04	Chrysler Concorde	28	30
		99-01	Chrysler LHS		30
35	36275	99-01	Chrysler 300M	31	30
		02-04	Chrysler 300M Except Special		30
33	36276	99-04	Jeep Grand Cherokee	38	15
34	36277	99-02	Mercury Villager	27	15
		99-02	Nissan Quest		15
34	36280	99-02	Saab 9-3	30	30
		03	Saab 9-3 Convertible		30
35	36282	00-06	Lincoln LS	27	30
46	36284	00-04	Subaru Legacy Sedan, Except Outback	36	20
		00-04	Subaru Legacy Wagon, Except Outback		20
		00-04	Subaru Outback Sedan, Except Sport		20
		00-04	Subaru Outback Wagon, Except Sport		20
41	36286	99-05	Saab 9-5	29	30
33	36287	00-05	Cadillac DeVille	30	20
		06-11	Cadillac DTS		20
41	36288	99-04	Oldsmobile Alero	33	20
		99-05	Pontiac Grand Am		20
45	36292	00-07	Chevrolet Monte Carlo Except SS Sport Appearance Pkg.	32	30
41	36293	00-04	Toyota Avalon	28	20
23	36296	96-03	Chrysler Town & Country	27	30
		04-07	Chrysler Town & Country Except w/Stow & Go Seats		30
		01-03	Chrysler Voyager		30
		96-03	Dodge Caravan		30
		04-07	Dodge Caravan Except w/Stow & Go Seats		30
		96-03	Dodge Grand Caravan		30
		04-07	Dodge Grand Caravan Except w/Stow & Go Seats		30
		96-00	Plymouth Grand Voyager		30
		96-00	Plymouth Voyager		30
37	36297	01-09	Volvo S60 Sedan	29	15
		01-07	Volvo V70 Wagon		15
		03-07	Volvo XC70 Wagon, AWD		15
34	36298	98-03	Toyota Sienna	24	15
40	36301	95-00	Chrysler Cirrus	35	60
		01-06	Chrysler Sebring 4 Dr.		60
		95-06	Dodge Stratus 4 Dr.		60

PC	PART NO.	YEARS	MAKE/MODEL	WGT LBS	IN
40	36301	96-00	Plymouth Breeze	35	60
33	36303	02-07	Jeep Liberty	30	15
41	36305	02-05	KIA Sedona	31	20
39	36309	00-05	Buick LeSabre	35	30
		06-09	Buick Lucerne Except Super & Special Edition		30
		01-03	Oldsmobile Aurora		30
		00-05	Pontiac Bonneville		30
20	36311	98-08	Subaru Forester	24	30
47	36313	00-06	Ford Taurus 4 Dr. Sedan	38	40
		00-06	Ford Taurus Wagon		40
		00-05	Mercury Sable Sedan		40
		00-05	Mercury Sable Wagon		40
42	36317	04-07	Chevrolet Malibu 4 Dr.	39	40
		08	Chevrolet Malibu Classic LS		40
		08	Chevrolet Malibu Classic LT		40
		06-07	Chevrolet Malibu SS 4 Dr.		50
41	36318	04-07	Ford Freestar	30	25
		04-07	Mercury Monterey		25
45	36320	05-07	Chrysler Town & Country w/Stow & Go Seats	38	25
		05-07	Dodge Grand Caravan w/Stow & Go Seats		25
35	36334	08-09	Subaru Legacy Sedan	26	25
		05-07	Subaru Legacy Sedan, Except Outback		25
		05-07	Subaru Legacy Wagon, Except Outback		25
		05-07	Subaru Outback Sedan, Except Sport		25
		05-09	Subaru Outback Wagon, Except Sport		25
23	36336	97-03	Lexus ES300 4 Dr.	34	15
		04-06	Lexus ES330 4 Dr.		15
		95-99	Toyota Avalon		15
		92-96	Toyota Camry		15
		97-06	Toyota Camry 4 Dr. Sedan		15
		99-03	Toyota Solara		15
33	36360	05-07	Ford Five Hundred	34	30
		05-07	Ford Freestyle		30
		08-09	Ford Taurus 4 Dr. Sedan		30
		08-09	Ford Taurus X		30
		05-07	Mercury Montego		30
		08-09	Mercury Sable Sedan		30
27	36361	05-07	Buick Terraza	26	40
		05-08	Chevrolet Uplander		40
		09	Chevrolet Uplander (Canada Only)		40
		97-05	Chevrolet Venture		40
		97-04	Oldsmobile Silhouette		40
		99-05	Pontiac Montana		40
		05-06	Pontiac Montana SV6		40
		07-09	Pontiac Montana SV6 (Canada Only)		40
		97-98	Pontiac Trans Sport		40
		05-07	Saturn Relay		40
16	36362	06-10	Jeep Commander	10	20
		05-10	Jeep Grand Cherokee Except SRT-8		90
32	36363	05-09	Hyundai Tucson	24	25
		05-10	KIA Sportage 4 Cyl.		25
		05-10	KIA Sportage 6 Cyl.		25
37	36374	05-09	Buick Allure (Canada Only)	28	30
		97-05	Buick Century Sedan		30
		05-09	Buick LaCrosse Except Super		30
		98-02	Oldsmobile Intrigue		30
39	36378	04-08	Toyota Solara	25	15
34	36379	04-07	Chevrolet Malibu Maxx LS	33	25
		04-07	Chevrolet Malibu Maxx LT		25
35	36407	00-13	Chevrolet Impala	38	30
18	36408	05-17	Chevrolet Equinox	28	25
		10-17	GMC Terrain		25
		06-09	Pontiac Torrent		25
		02-07	Saturn Vue Except Redline		25
20	36416	07-12	Lexus ES350	33	45
		07-11	Toyota Camry 4 Dr. Sedan, Except Hybrid		45
		07-11	Toyota Camry Hybrid 4 Dr. Sedan		45
32	36417	99-17	Honda Odyssey	38	20
34	36419	07-12	Mazda CX-7	28	40
22	36423	07-10	Jeep Compass	24	15
		11-17	Jeep Compass (Old Body Style)		30
		07-10	Jeep Compass Rallye Edition		30
		07-17	Jeep Patriot		15
		07-17	Jeep Patriot		30
22	36424	07-17	Jeep Wrangler Except w/Right Hand Drive, Hard Rock Edition, 75th Anniversary Edition & vehicles with Mopar Off Road Bumper #82213654	16	20

CLASS II RECEIVER HITCH INDEX

PC	PART NO.	YEARS	MAKE/MODEL	WGT LBS	IN
22	364241	18	Jeep Wrangler JK Except w/Right Hand Drive, Hard Rock Edition, 75th Anniversary Edition & vehicles with Mopar Off Road Bumper #82213654	16	20
		18	Jeep Wrangler JK Right Hand Drive, Except Hard Rock Edition, 75th Anniversary Edition & vehicles with Mopar Off Road Bumper #82213654		20
		18-19	Jeep Wrangler JL (New Body Style)		20
		07-17	Jeep Wrangler Right Hand Drive, Except Hard Rock Edition, 75th Anniversary Edition & vehicles with Mopar Off Road Bumper #82213654		20
34	36425	02-07 01-05	Buick Rendezvous Pontiac Aztek	27	40
36	36426	05-09	Pontiac G6	30	30
21	36427	07-09	Acura RDX	27	15
33	36447	07-10	Ford Edge Except Sport	34	45
		07-10	Lincoln MKX		45
30	36448	07-10	Chrysler Sebring Except Convertible	27	30
		08-10	Dodge Avenger		30
25	36450	08-09	Saturn Vue	28	15
31	36451	08-12	Jeep Liberty	31	15
24	36455	08-16	Chrysler Town & Country	34	20
		08-19	Dodge Grand Caravan		20
		12-15	RAM C/V Tradesman		20
		09-12	Volkswagen Routan		20
		13-14	Volkswagen Routan (Canada Only)		20
		22	36466	07-16	Volvo S80 Sedan
10	36474	09-17	Volkswagen Tiguan	6	20
30	36477	09-16	Lincoln MKS	44	30
24	36479	08-12	Chevrolet Malibu Except LTZ	31	45
		08-12	Chevrolet Malibu LTZ		45
		07-09	Saturn Aura		45
30	36486	09-14	Hyundai Genesis 4 Dr. Sedan	29	60
36	36492	10-19	Ford Taurus 4 Dr. Sedan	38	30
25	36493	10-19	Subaru Legacy Sedan	33	45
		10-19	Subaru Outback Wagon, Except Sport		45
22	36501	05-12	Ford Escape	32	20
		05-11	Mazda Tribute		20
		05-11	Mercury Mariner		20
25	36502	10-11	Buick Lucerne	36	25
		08-09	Buick Lucerne Super & Special Edition		25
25	36509	11-19	Mitsubishi Outlander Sport Except PHEV	26	30
		11-14	Mitsubishi RVR (Canada Only)		30
21	36510	10-15	Hyundai Tucson	33	20
		11-16	KIA Sportage		20
29	36511	10-12	Hyundai Santa Fe	38	15
		11-13	KIA Sorento EX V6, w/Factory Tow Package		15
		11-13	KIA Sorento Except SX V6 & EX V6 w/Factory Tow Package		15
		11-13	KIA Sorento SX V6		15
29	36512	09-16	Toyota Venza	32	20
27	36513	04-14	Toyota Sienna	26	20
		15-20	Toyota Sienna Except SE		20
		15-20	Toyota Sienna SE		20
58	36519t	10-12	Buick LaCrosse AWD	40	25
		10-12	Buick LaCrosse FWD		20
		11-13	Buick Regal Except GS		20
16	36520	12-16	Honda CR-V	22	40
27	36521	09-13	Subaru Forester	30	35
46	36522t	10-13	Buick LaCrosse	33	25
		11-13	Buick Regal Except GS		20
		13	Chevrolet Malibu (Canada Only)		20
		13	Chevrolet Malibu Except LTZ & Canada Models		20
13	Chevrolet Malibu LTZ Except Canada Models		20		
21	36523	14-18	Subaru Forester	21	30
38	36524	13-19	Ford Escape	37	15
28	36525	14-17	KIA Rondo (Canada Only)	30	25
38	36529	13-19	Ford Escape	34	20
		13-19	Ford Escape		60
29	36530	13-18	Lexus ES350 Except Hybrid	32	40
32	36535t	13	Lexus GS350	26	60
27	36536	13-18	Hyundai Santa Fe Sport (5 Passenger)	20	30
		14-15	KIA Sorento w/ I4 Engine		30
		14-15	KIA Sorento w/ V6 Engine		30
42	36538	10-16	Buick LaCrosse	39	35
		11-17	Buick Regal		35
		13-19	Cadillac XTS		35
		13-19	Chevrolet Impala Except Impala Limited		35
		14-19	Chevrolet Impala Limited		35

PC	PART NO.	YEARS	MAKE/MODEL	WGT LBS	IN
42	36538	13-15	Chevrolet Malibu Except LTZ & Canada Models	39	35
		16	Chevrolet Malibu Limited LTZ, Except Canada Models (Old Body Style)		35
		16	Chevrolet Malibu Limited, Except LTZ & Canada Models (Old Body Style)		35
23	36540	14-15	Chevrolet Malibu LTZ Except Canada Models		35
		13-18	Toyota Avalon	35	40
46	36541	12-19	Toyota Camry Including Hybrid		40
		14-19	Acura RLX	19	60
18	36542	08-13	Nissan Rogue Except Krom	28	15
		14-19	Nissan Rogue Except Sport		15
		14	Nissan Rogue Select		15
48	36543	14	Chevrolet Impala Eco, Except Impala Limited	37	30
		14	Chevrolet Impala LS Except Impala Limited		30
		14	Chevrolet Impala LT Except Impala Limited		30
		14	Chevrolet Impala LTZ Except Impala Limited		30
28	36544	12-17	Hyundai Azera	26	20
		14	KIA Cadenza		20
47	36546t	14	Buick LaCrosse	35	30
25	36548	05-19	Chrysler 300	35	30
		05-19	Chrysler 300		40
		08-19	Dodge Challenger Except Models w/Quad Tip Exhaust		30
		06-19	Dodge Charger		30
		05-08	Dodge Magnum		30
		25	36554	13-19	Buick Encore
26	36572	13-16	Chevrolet Trax		40
		17-19	Chevrolet Trax Except LS		40
		17-19	Chevrolet Trax LS		40
37	36586	16-18	Hyundai Tucson	26	30
27	36587	15-18	Lincoln MKC	41	45
24	36588	15-18	Jeep Renegade	33	30
24	36588	06-18	Toyota RAV4	28	20
23	36592t	16-19	Chevrolet Malibu Except Premier (New Body Style)	27	80
		16-19	Chevrolet Malibu Premier (New Body Style)		80
29	36593	17-19	KIA Sportage Except SX & SX Turbo	28	30
23	36594t	17-19	Buick LaCrosse	27	80
27	36596	17-19	Lincoln Continental	26	50
16	36597	17-19	Honda CR-V	28	20
25	36598	17-19	Jeep Compass (New Body Style)	36	40
28	36600	17-19	KIA Niro Except Plug-In-Hybrid	28	40
23	36601	13-19	Mazda CX-5	28	20
		13-19	Mazda CX-5		30
23	36602t	13-16	Mazda CX-5	28	30
26	36633	18-19	Honda Odyssey With Fuse Provisions	46	80
		18-19	Honda Odyssey Without Fuse Provisions		25
30	36635	18-19	Volkswagen Atlas	39	25
22	36642	18-20	Chevrolet Equinox Except Premier or Models w/1.6L Diesel	28	35
		18-20	Chevrolet Equinox Premier, Except Models w/1.6L Diesel		35
		18-19	GMC Terrain Except Diesel		35
22	36643	19	Toyota Avalon	35	40
		18-19	Toyota Camry Except Hybrid		40
22	36644	18-19	Subaru Crosstrek Except Hybrid	31	60
		18-19	Subaru Crosstrek Hybrid		60
		18-19	Subaru Impreza 5 Dr. Wagon, Except WRX STi & w/Quad Exhaust Outlets		60
25	36650	18-19	Volkswagen Tiguan 4 Motion	33	20
		18-19	Volkswagen Tiguan Except 4 Motion		20
20	36652	17-19	Buick LaCrosse	27	80
		18-19	Buick Regal Sportback		80
		16-19	Chevrolet Malibu Except Premier (New Body Style)		80
		16-19	Chevrolet Malibu Premier (New Body Style)		80
27	36660	18	Ford EcoSport	31	45
41	36661	18-19	Buick Regal TourX	52	30
21	36671	19	Subaru Forester	28	30
24	36675	19	Toyota RAV4	45	35
24	36772	16-19	Mazda CX-9	37	30
22	36787	20	Ford Explorer	32	
26	36798	17-19	Chrysler Pacifica Hybrid (Needs Conversion Kit: 76046SK)	42	45
		17-19	Chrysler Pacifica Limited		45
		17-19	Chrysler Pacifica LX		45
		17-19	Chrysler Pacifica Touring		45
		17-19	Chrysler Pacifica Touring L		45
		17-19	Chrysler Pacifica Touring L Plus		45
		17-19	Chrysler Pacifica Touring Plus		45
		17-19	Chrysler Pacifica Touring Plus		45

CLASS III/IV RECEIVER HITCH INDEX

PC	PART NO.	YEARS	MAKE/MODEL	WGT LBS	IN
CLASS III/IV- RECEIVER					
34	41001	63-86	Chevrolet C10 w/8' Bed	52	40
		63-86	Chevrolet C20 w/8' Bed		40
		88-91	Chevrolet C2500 Crew Cab w/8' Bed		40
		63-86	Chevrolet C30 w/8' Bed		45
		63-86	Chevrolet C30 w/8' Bed		40
		88-91	Chevrolet C3500 Crew Cab w/8' Bed		40
		63-86	Chevrolet K10 w/8' Bed		40
		63-86	Chevrolet K20 w/8' Bed		40
		88-91	Chevrolet K2500 Crew Cab w/8' Bed		40
		73-86	Chevrolet K30 w/8' Bed		40
		88-91	Chevrolet K3500 Crew Cab w/8' Bed		40
		63-72	Ford F-100		40
		63-74	Ford F-250		40
		63-74	Ford F-350		40
		99-00	Ford F-350 Super Duty Cab & Chassis, w/34" Wide Frames		40
		63-65	GMC 1000 Series w/8' Bed		40
		63-65	GMC 1500 Series w/8' Bed		40
		63-65	GMC 2500 Series w/8' Bed		40
		63-66	GMC 3000 w/8' Bed		40
		63-66	GMC 3500 w/8' Bed		40
		75-78	GMC C15 w/8' Bed		40
		67-74	GMC C15/C1500 w/8' Bed		40
		79-86	GMC C1500 w/8' Bed		40
		67-78	GMC C25 w/8' Bed		40
		88-91	GMC C2500 Crew Cab w/8' Bed		40
		79-86	GMC C2500 w/8' Bed		40
		67-78	GMC C35 w/8' Bed		40
		88-91	GMC C3500 Crew Cab w/8' Bed		40
		79-86	GMC C3500 w/8' Bed		40
		67-78	GMC K15 w/8' Bed		40
		79-86	GMC K1500 w/8' Bed		40
		67-78	GMC K25 w/8' Bed		40
		79-86	GMC K2500 w/8' Bed		40
		67-78	GMC K35 w/8' Bed		40
		88-91	GMC K3500 Crew Cab w/8' Bed		40
		79-86	GMC K3500 w/8' Bed		40
		74	International 100		30
		69-70	International 1000D		40
		71-73	International 1010		30
		69-70	International 1100D		30
		71-73	International 1110		30
69-70	International 1200D		30		
71-73	International 1210		30		
69-70	International 1300D		30		
71-73	International 1310		30		
74-75	International 150		30		
69-71	International 1500D		30		
74-75	International 200		30		
25	41004	80-83	Ford F-100 Except w/Custom Fascia	52	30
		87-96	Ford F-150		30
		80-86	Ford F-150 Except w/Custom Fascia		30
		87-96	Ford F-250		30
		80-86	Ford F-250 Except w/Custom Fascia		30
		97	Ford F-250 Heavy Duty		30
		87-96	Ford F-350		30
		80-86	Ford F-350 Except w/Custom Fascia		30
		97	Ford F-350 Heavy Duty		30
		96-97	Lexus LX450	40	30
		91-97	Toyota Land Cruiser		30
38	41116	92-09	Ford Crown Victoria	48	30
		79-82	Ford LTD		30
		83-91	Ford LTD Crown Victoria		30
		80-83	Lincoln Mark VI		30
		81-11	Lincoln Town Car		30
		83-11	Mercury Grand Marquis		30
		03-04	Mercury Marauder		30
		79-82	Mercury Marquis Sedan		30
		79-82	Mercury Marquis Sedan		30
52	41121	78-95	Chevrolet G10	50	30
		78-95	Chevrolet G20		30
		78-95	Chevrolet G30		30
		96	Chevrolet G30 Classic & Sport Full Size w/Lo-Mount Taillights		30
		79-95	GMC G1500		30
		79-95	GMC G2500		30
		79-95	GMC G3500		30

PC	PART NO.	YEARS	MAKE/MODEL	WGT LBS	IN
52	41121	96	GMC G3500 Vandura & Rally Full Size w/Lo-Mount Taillights	50	30
34	41504	63-86	Chevrolet C10 w/Deep Drop Bumper	67	40
		63-86	Chevrolet C20 w/Deep Drop Bumper		40
		88-91	Chevrolet C2500 Crew Cab, w/Deep Drop Bumper		40
		63-86	Chevrolet C30 w/Deep Drop Bumper		40
		88-91	Chevrolet C3500 Crew Cab, w/Deep Drop Bumper		40
		63-86	Chevrolet K10 w/Deep Drop Bumper		40
		63-86	Chevrolet K20 w/Deep Drop Bumper		40
		88-91	Chevrolet K2500 Crew Cab, w/Deep Drop Bumper		40
		73-86	Chevrolet K30 w/Deep Drop Bumper		40
		88-91	Chevrolet K3500 Crew Cab, w/Deep Drop Bumper		40
		68-89	Dodge D100 w/Deep Drop Bumper		40
		77-93	Dodge D150 w/Deep Drop Bumper		40
		68-80	Dodge D200 w/Deep Drop Bumper		40
		81-85	Dodge D250 w/Deep Drop Bumper		40
		68-80	Dodge D300 w/Deep Drop Bumper		40
		81-85	Dodge D350 w/Deep Drop Bumper		40
		94-01	Dodge Ram 1500 w/Deep Drop Bumper		40
		94-02	Dodge Ram 2500 w/Deep Drop Bumper		40
		94-02	Dodge Ram 3500 w/Deep Drop Bumper		40
		74-88	Dodge Ramcharger w/Deep Drop Bumper, Except w/Skid Shield		40
		67-89	Dodge W100 w/Deep Drop Bumper		40
		77-93	Dodge W150 w/Deep Drop Bumper		40
		67-80	Dodge W200 w/Deep Drop Bumper		40
		81-93	Dodge W250 w/Deep Drop Bumper		40
		67-80	Dodge W300 w/Deep Drop Bumper		40
		81-93	Dodge W350 w/Deep Drop Bumper		40
		78-86	Ford Bronco w/Deep Drop Bumper		40
		89-97	Ford F Super Duty Cab & Chassis, w/34" Wide Frames & 161" Wheelbase & w/Deep Drop Bumper		40
		63-79	Ford F-100 w/Deep Drop Bumper		40
		80-83	Ford F-100 w/Deep Drop Bumper, Except w/Custom Fascia		40
		75-96	Ford F-150 w/Deep Drop Bumper		40
		80-86	Ford F-150 w/Deep Drop Bumper, Except w/Custom Fascia		40
		97	Ford F-250 Heavy Duty, w/Deep Drop Bumper		40
		63-96	Ford F-250 w/Deep Drop Bumper		40
		80-86	Ford F-250 w/Deep Drop Bumper, Except w/Custom Fascia		40
		97	Ford F-350 Heavy Duty, w/Deep Drop Bumper		40
		99-00	Ford F-350 Super Duty Cab & Chassis, w/34" Wide Frames & w/Deep Drop Bumper		40
		63-96	Ford F-350 w/Deep Drop Bumper		40
		80-86	Ford F-350 w/Deep Drop Bumper, Except w/Custom Fascia		40
		63-65	GMC 1000 Series w/Deep Drop Bumper		40
		63-65	GMC 1500 Series w/Deep Drop Bumper		40
63-65	GMC 2500 Series w/Deep Drop Bumper		40		
63-66	GMC 3000 w/Deep Drop Bumper		40		
63-66	GMC 3500 w/Deep Drop Bumper		40		
67-78	GMC C15 w/Deep Drop Bumper		40		
79-86	GMC C1500 w/Deep Drop Bumper		40		
67-78	GMC C25 w/Deep Drop Bumper		40		
88-91	GMC C2500 Crew Cab, w/Deep Drop Bumper		40		
79-86	GMC C2500 w/Deep Drop Bumper		40		
67-78	GMC C35 w/Deep Drop Bumper		40		
88-91	GMC C3500 Crew Cab, w/Deep Drop Bumper		40		
79-86	GMC C3500 w/Deep Drop Bumper		40		
67-78	GMC K15 w/Deep Drop Bumper		40		
79-86	GMC K1500 w/Deep Drop Bumper		40		
67-78	GMC K25 w/Deep Drop Bumper		40		
79-86	GMC K2500 w/Deep Drop Bumper		40		
67-78	GMC K35 w/Deep Drop Bumper		40		
79-91	GMC K3500 w/Deep Drop Bumper		40		
69-70	International 1000D w/Deep Drop Bumper		40		
74-81	Plymouth Trailduster w/Deep Drop Bumper, Except w/Skid Shield		40		
41	41511	99-00	Cadillac Escalade	46	30
		92-94	Chevrolet Blazer Full Size		30
		92-99	Chevrolet Suburban C1500		30
		92-99	Chevrolet Suburban C2500		30
		92-99	Chevrolet Suburban K1500		30
		92-99	Chevrolet Suburban K2500		30
		95-00	Chevrolet Tahoe		30

CLASS III/IV RECEIVER HITCH INDEX

PC	PART NO.	YEARS	MAKE/MODEL	WGT LBS	IN				
41	41511	92-99	GMC Suburban C1500	46	30				
		92-99	GMC Suburban C2500						
		92-99	GMC Suburban K1500						
		92-99	GMC Suburban K2500						
		92-00	GMC Yukon						
		99-00	GMC Yukon Denali						
33	41521	96-14	Chevrolet Express 1500	46	15				
		96-19	Chevrolet Express 2500						
		96-19	Chevrolet Express 3500						
		96-14	GMC Savana 1500						
		96-17	GMC Savana 2500						
		96-17	GMC Savana 3500						
		37	41522			88-99	Chevrolet C1500 w/Aftermarket Roll Pan	27	40
88-99	Chevrolet C2500 w/Aftermarket Roll Pan								
88-00	Chevrolet C3500 w/Aftermarket Roll Pan								
88-99	Chevrolet K1500 w/Aftermarket Roll Pan								
88-99	Chevrolet K2500 w/Aftermarket Roll Pan								
88-00	Chevrolet K3500 w/Aftermarket Roll Pan								
88-99	GMC C1500 w/Aftermarket Roll Pan								
88-00	GMC C2500 w/Aftermarket Roll Pan								
88-00	GMC C3500 w/Aftermarket Roll Pan								
88-99	GMC K1500 w/Aftermarket Roll Pan								
88-00	GMC K2500 w/Aftermarket Roll Pan								
88-00	GMC K3500 w/Aftermarket Roll Pan								
44	41524			88-99	Chevrolet C1500	48	20		
				92-00	Chevrolet C2500 Crew Cab				
				88-99	Chevrolet C2500 Regular & Extended Cabs				
				92-00	Chevrolet C3500 Crew Cab				
				88-00	Chevrolet C3500 Regular & Extended Cabs				
		88-99	Chevrolet K1500						
		92-00	Chevrolet K2500 Crew Cab						
		88-99	Chevrolet K2500 Regular & Extended Cabs						
		92-00	Chevrolet K3500 Crew Cab						
		88-00	Chevrolet K3500 Regular & Extended Cabs						
		88-99	GMC C1500						
		88-00	GMC C2500						
		88-00	GMC C3500						
		88-99	GMC K1500						
		88-00	GMC K2500						
		88-00	GMC K3500						
		38	41525	88-99	Chevrolet C1500			53	20
92-00	Chevrolet C2500 Crew Cab								
88-99	Chevrolet C2500 Regular & Extended Cabs								
92-00	Chevrolet C3500 Crew Cab								
88-00	Chevrolet C3500 Regular & Extended Cabs								
88-99	Chevrolet K1500								
92-00	Chevrolet K2500 Crew Cab								
88-99	Chevrolet K2500 Regular & Extended Cabs								
92-00	Chevrolet K3500 Crew Cab								
88-00	Chevrolet K3500 Regular & Extended Cabs								
88-99	GMC C1500								
88-00	GMC C2500								
88-00	GMC C3500								
88-99	GMC K1500								
88-00	GMC K2500								
88-00	GMC K3500								
41	41527	97-02	Ford Expedition	54	15				
		98-02	Lincoln Navigator						
49	41528	88-99	Chevrolet C1500 w/10" Deep Drop Bumper	50	20				
		92-00	Chevrolet C2500 Crew Cab w/10" Deep Drop Bumper						
		88-99	Chevrolet C2500 Regular & Extended Cabs, w/10" Deep Drop Bumper						
		92-00	Chevrolet C3500 Crew Cab w/10" Deep Drop Bumper						
		88-00	Chevrolet C3500 Regular & Extended Cabs, w/10" Deep Drop Bumper						
		88-99	Chevrolet K1500 w/10" Deep Drop Bumper						
		92-00	Chevrolet K2500 Crew Cab w/10" Deep Drop Bumper						
		88-99	Chevrolet K2500 Regular & Extended Cabs, w/10" Deep Drop Bumper						
		92-00	Chevrolet K3500 Crew Cab w/10" Deep Drop Bumper						
		88-00	Chevrolet K3500 Regular & Extended Cabs, w/10" Deep Drop Bumper						
		88-99	GMC C1500 w/10" Deep Drop Bumper						
		88-00	GMC C2500 w/10" Deep Drop Bumper						
		88-00	GMC C3500 w/10" Deep Drop Bumper						
		88-99	GMC K1500 w/10" Deep Drop Bumper						
		88-00	GMC K2500 w/10" Deep Drop Bumper						

PC	PART NO.	YEARS	MAKE/MODEL	WGT LBS	IN
49	41528	88-00	GMC K3500 w/10" Deep Drop Bumper	50	20
31	41531	97-06	Jeep TJ (Canada Only)	26	15
		97-06	Jeep Wrangler		
		97-06	Jeep Wrangler		
35	41533	94	Dodge Van, B150 Except w/Factory Step Bumper	50	20
		95-98	Dodge Van, B1500 Except w/Factory Step Bumper		
		94	Dodge Van, B250 Except w/Factory Step Bumper		
		95-98	Dodge Van, B2500 Except w/Factory Step Bumper		
		94	Dodge Van, B350 Except w/Factory Step Bumper		
		95-98	Dodge Van, B3500 Except w/Factory Step Bumper		
		99-03	Dodge Van, Ram 1500 Except w/Factory Step Bumper		
		99-03	Dodge Van, Ram 2500 Except w/Factory Step Bumper		
		99-03	Dodge Van, Ram 3500 Except w/Factory Step Bumper		
		39	41534		
03-07	Chevrolet Silverado 1500 (Classic)				
01-02	Chevrolet Silverado 1500 HD				
03-07	Chevrolet Silverado 1500 HD (Classic)				
99-04	Chevrolet Silverado 2500				
99-02	GMC Sierra 1500				
03-07	GMC Sierra 1500 (Classic)				
01-03	GMC Sierra 1500 HD				
05-07	GMC Sierra 1500 HD (Classic)				
99-04	GMC Sierra 2500				
53	41536	94-01	Dodge Ram 1500	46	15
		94-02	Dodge Ram 2500		
		94-02	Dodge Ram 3500		
29	41537	99-04	Chevrolet Tracker	29	15
		99-05	Suzuki Grand Vitara		
		99-04	Suzuki Vitara		
		02-06	Suzuki XL-7		
35	41541	99-03	Lexus RX300	34	15
		01-03	Toyota Highlander		
25	41543	01-06	Hyundai Santa Fe	28	35
46	41544	01-02	Chevrolet Silverado 2500 HD	55	20
		03-07	Chevrolet Silverado 2500 HD (Classic)		
		01-02	Chevrolet Silverado 3500		
		03-07	Chevrolet Silverado 3500 (Classic)		
		01-02	GMC Sierra 2500 HD		
		03-07	GMC Sierra 2500 HD (Classic)		
		01-02	GMC Sierra 3500		
03-07	GMC Sierra 3500 (Classic)				
30	41547	99-00	Ford F-350 Super Duty Cab & Chassis, w/34" Wide Frames	32	60
		99-17	Ford F-450 Super Duty Cab & Chassis, w/34" Wide Frames		
		99-17	Ford F-550 Super Duty Cab & Chassis, w/34" Wide Frames		
54	41549	04-05 06	Ford F-150 Lincoln Mark LT (Built Before 8/2005)	60	30
38	41551	04-15	Nissan Titan	40	15
36	75020f	87-95	Nissan Pathfinder	38	40
62	75031	84-95	Toyota Pickup Except T-100	60	60
35	75033	88-99	Chevrolet C1500	46	20
		92-00	Chevrolet C2500 Crew Cab		
		88-99	Chevrolet C2500 Regular & Extended Cabs		
		92-00	Chevrolet C3500 Crew Cab		
		88-00	Chevrolet C3500 Regular & Extended Cabs		
		88-99	Chevrolet K1500		
		92-00	Chevrolet K2500 Crew Cab		
		88-99	Chevrolet K2500 Regular & Extended Cabs		
		92-00	Chevrolet K3500 Crew Cab		
		88-00	Chevrolet K3500 Regular & Extended Cabs		
34	75034	63-86	Chevrolet C10	36	30
		63-86	Chevrolet C10		
		63-86	Chevrolet C20		
		63-86	Chevrolet C20		
		88-91	Chevrolet C2500 Crew Cab		
		63-86	Chevrolet C30		
		63-86	Chevrolet C30		
		88-91	Chevrolet C3500 Crew Cab		
		63-86	Chevrolet K10		
		63-86	Chevrolet K10		

CLASS III/IV RECEIVER HITCH INDEX

PC	PART NO.	YEARS	MAKE/MODEL	WGT					
				LBS	IN				
34	75034	63-86	Chevrolet K20	36	40				
		63-86	Chevrolet K20						
		88-91	Chevrolet K2500 Crew Cab						
		73-86	Chevrolet K30						
		88-91	Chevrolet K3500 Crew Cab						
		63-72	Ford F-100						
		63-72	Ford F-250						
		63-74	Ford F-350						
		63-65	GMC 1000 Series						
		63-65	GMC 1500 Series						
		63-65	GMC 2500 Series						
		63-66	GMC 3000						
		63-66	GMC 3500						
		75-78	GMC C15						
		67-74	GMC C15/C1500						
		79-86	GMC C1500						
		67-78	GMC C25						
		79-86	GMC C2500						
		88-91	GMC C2500 Crew Cab						
		67-78	GMC C35						
		79-86	GMC C3500						
		88-91	GMC C3500 Crew Cab						
		67-78	GMC K15						
		67-78	GMC K15						
		79-86	GMC K1500						
		67-78	GMC K25						
		79-86	GMC K2500						
		67-78	GMC K35						
		79-86	GMC K3500						
		88-91	GMC K3500 Crew Cab						
		74	International 100						
		69-70	International 1000D						
		71-73	International 1010						
		69-70	International 1100D						
		71-73	International 1110						
		69-70	International 1200D						
		71-73	International 1210						
		69-70	International 1300D						
		71-73	International 1310						
		74-75	International 150						
		69-71	International 1500D						
		74-75	International 200						
		35	75037			99-00	Cadillac Escalade	40	30
						92-94	Chevrolet Blazer Full Size		
						92-99	Chevrolet Suburban C1500		
						92-99	Chevrolet Suburban C2500		
						92-99	Chevrolet Suburban K1500		
						92-99	Chevrolet Suburban K2500		
						95-00	Chevrolet Tahoe		
						92-99	GMC Suburban C1500		
92-99	GMC Suburban C2500								
92-99	GMC Suburban K1500								
92-99	GMC Suburban K2500								
92-00	GMC Yukon								
99-00	GMC Yukon Denali								
34	75038			68-79	Dodge D100	38	30		
				77-93	Dodge D150				
		68-80	Dodge D200						
		81-93	Dodge D250						
		68-80	Dodge D300						
		81-93	Dodge D350						
		97-04	Dodge Dakota						
		67-89	Dodge W100						
		77-93	Dodge W150						
		67-80	Dodge W200						
		81-93	Dodge W250						
		67-80	Dodge W300						
		81-93	Dodge W350						
		78-96	Ford Bronco						
		75-79	Ford F-100						
		80-83	Ford F-100 Except w/Custom Fascia						
		87-96	Ford F-150						
		80-86	Ford F-150 Except w/Custom Fascia						
		75-96	Ford F-250						
		80-86	Ford F-250 Except w/Custom Fascia						
		97	Ford F-250 Heavy Duty						
		75-96	Ford F-350						

PC	PART NO.	YEARS	MAKE/MODEL	WGT	
				LBS	IN
34	75038	80-86	Ford F-350 Except w/Custom Fascia	38	30
		97	Ford F-350 Heavy Duty		
30	75041	93-98	Jeep Grand Cherokee	40	40
		93	Jeep Grand Wagoneer		
41	75043†	96-99	Acura SLX	41	40
		92-02	Isuzu Trooper		
37	75049	94-97	Honda Passport	34	40
		91-97	Isuzu Rodeo		
34	75051	83-97	Chevrolet S10 w/Standard Bed & Step Bumper	37	40
		83-90	GMC S15 w/Standard Bed & Step Bumper		
		96-97	Isuzu Hombre w/Step Bumper		
30	75054	84-01	Jeep Cherokee	36	40
		84-90	Jeep Wagoneer		
43	75055	95-98	Ford Windstar	38	40
		03	Ford Windstar (Built After 11/2002)		
		99-03	Ford Windstar (Built Before 11/2002)		
28	75065	97-03	Ford F-150 Flareside	44	30
		04	Ford F-150 Heritage Flareside		
		04	Ford F-150 Heritage Styleside		
		97-03	Ford F-150 Styleside		
		00-03	Ford F-150 SuperCrew		
		97-99	Ford F-250 Styleside		
42	75071	97-02	Ford Expedition	47	15
		98-02	Lincoln Navigator		
31	75073	87-04	Dodge Dakota	39	15
		87-04	Dodge Dakota		
35	75075	97-04	Mitsubishi Montero Sport	34	20
34	75077	97-03	Infiniti QX4	32	20
		96-04	Nissan Pathfinder		
32	75078	95-04	Toyota Tacoma (App. starts with 95-1/2)	42	40
21	75079	95-05	Chevrolet Blazer Downsize	29	15
		99-01	Chevrolet Blazer Trailblazer		
		95-05	GMC Jimmy Downsize		
		96-01	Oldsmobile Bravada		
34	75081	98-03	Dodge Durango	44	15
24	75082	93-11	Ford Ranger	30	20
		83-92	Ford Ranger Except GT		
		94-09	Mazda B2300		
		98-01	Mazda B2500		
		94-08	Mazda B3000		
		94-09	Mazda B4000		
34	75083	91-00	Ford Explorer	30	15
		01-03	Ford Explorer 2 Dr. Sport		
		01	Ford Explorer 4 Dr.		
		91-94	Mazda Navajo		
30	75085	97-01	Mercury Mountaineer	35	40
		98-04	Chevrolet S10		
		96-97	Chevrolet S10 w/Sportside Bed & Non-Towing Bumper		
		98-04	GMC Sonoma		
		96-97	GMC Sonoma w/Sportside Bed & Non-Towing Bumper		
34	75087	98-00	Isuzu Hombre w/Step Bumper	21	30
		98-02	Mercedes-Benz ML320		
		03-05	Mercedes-Benz ML350		
		99-01	Mercedes-Benz ML430		
		02-05	Mercedes-Benz ML500		
42	75089	93-98	Mercury Villager	37	15
		93-98	Nissan Quest		
41	75090	94	Dodge Van, B150 Except w/Factory Step Bumper	41	20
		95-98	Dodge Van, B1500 Except w/Factory Step Bumper		
		94	Dodge Van, B250 Except w/Factory Step Bumper		
		95-98	Dodge Van, B2500 Except w/Factory Step Bumper		
		94	Dodge Van, B350 Except w/Factory Step Bumper		
		95-98	Dodge Van, B3500 Except w/Factory Step Bumper		
		99-03	Dodge Van, Ram 1500 Except w/Factory Step Bumper		
		99-03	Dodge Van, Ram 2500 Except w/Factory Step Bumper		
		99-03	Dodge Van, Ram 3500 Except w/Factory Step Bumper		
		99-03	Dodge Van, Ram 3500 Except w/Factory Step Bumper		
42	75091	96-02	Toyota 4Runner	40	30
32	75092	98-01	Honda Passport w/Door Mounted Spare	34	15
		98-01	Isuzu Rodeo w/Door Mounted Spare		
30	75093	98-02	Honda Passport w/Under Vehicle Spare	30	15
		02-03	Isuzu Axiom w/Under Vehicle Spare		
		98-04	Isuzu Rodeo w/Under Vehicle Spare, Except w/3.5L		
45	75095	98-07	Lexus LX470	36	20
		98-07	Toyota Land Cruiser		
31	75096	91-00	Ford Explorer	38	15
		91-00	Ford Explorer		
		01-03	Ford Explorer 2 Dr. Sport		

CLASS III/IV RECEIVER HITCH INDEX

PC	PART NO.	YEARS	MAKE/MODEL	WGT LBS	IN
31	75096	01	Ford Explorer 4 Dr.	38	15
		91-94	Mazda Navajo		
		97-01	Mercury Mountaineer		
25	75099	88-99	Chevrolet C1500	50	20
		92-00	Chevrolet C2500 Crew Cab		
		88-99	Chevrolet C2500 Regular & Extended Cabs		
		92-00	Chevrolet C3500 Crew Cab		
		88-00	Chevrolet C3500 Regular & Extended Cabs		
		88-99	Chevrolet K1500		
		92-00	Chevrolet K2500 Crew Cab		
		88-99	Chevrolet K2500 Regular & Extended Cabs		
		92-00	Chevrolet K3500 Crew Cab		
		88-99	GMC C1500		
		88-00	GMC C2500		
		88-00	GMC C3500		
		88-99	GMC K1500		
		88-00	GMC K2500		
		88-00	GMC K3500		
		23	75101		
94-02	Dodge Ram 2500				
94-02	Dodge Ram 3500				
41	75102†	99-02	Mercury Villager	32	15
		99-02	Nissan Quest		
30	75105	00-06	Toyota Tundra	50	15
41	75107	00-04	Nissan Xterra	28	15
45	75108	00-03	Mazda MPV Except w/Ground Effects	49	15
32	75112	01-05	Ford Explorer Sport Trac	38	15
46	75116	01-06	Mitsubishi Montero Except Montero Sport	40	20
36	75118	01-04	Ford Escape	31	35
		01-04	Mazda Tribute		
30	75119	96-03	Chrysler Town & Country	38	30
		04-07	Chrysler Town & Country Except w/Stow & Go Seats		
		01-03	Chrysler Voyager		
		96-03	Dodge Caravan		
		04-07	Dodge Caravan Except w/Stow & Go Seats		
		96-03	Dodge Grand Caravan		
		04-07	Dodge Grand Caravan Except w/Stow & Go Seats		
		96-00	Plymouth Grand Voyager		
		96-00	Plymouth Voyager		
		34	75120		
45	75121	78-95	Chevrolet G10	45	40
		78-95	Chevrolet G20		
		78-95	Chevrolet G30		
		96	Chevrolet G30 Classic & Sport Full Size w/Lo-Mount Taillights		
		79-95	GMC G1500		
		79-95	GMC G2500		
		79-95	GMC G3500		
96	GMC G3500 Vandura & Rally Full Size w/Lo-Mount Taillights				
33	75122	90-05	Chevrolet Astro Extended Body	47	30
		90-05	GMC Safari Extended Body		
42	75123†	83-94	Chevrolet Blazer S10	32	60
		84-91	Chevrolet Blazer S10 2 Dr.		
		84-91	Chevrolet Blazer S10 4 Dr.		
		92-94	GMC Jimmy Downsized		
		83	GMC S15 Jimmy		
		84-91	GMC S15 Jimmy 2 Dr.		
		84-91	GMC S15 Jimmy 4 Dr.		
		91-94	Oldsmobile Bravada		
31	75125	96-05	Toyota RAV4	25	15
57	75126	01-07	Toyota Sequoia Except Models w/OEM Hitch	42	20
23	75128	02-07	Jeep Liberty	39	15
44	75129	73-91	Chevrolet Blazer Full Size	34	30
		75-86	Chevrolet Blazer K5		
		73-91	GMC Jimmy Full Size		
41	75131	02-05	KIA Sedona	33	30
47	75132	02-05	Ford Explorer 4 Dr.	38	20
		03-05	Lincoln Aviator		
		02-05	Mercury Mountaineer		
14	75135	02-03	Dodge Ram 1500 (Built Before 11/2002)	22	15
32	75138	02-07	Buick Rendezvous	38	55
		01-05	Pontiac Aztek		
31	75139	99-04	Jeep Grand Cherokee	43	15
30	75140	78-80	Dodge Van, B100	41	30
		81-94	Dodge Van, B150		
		95-98	Dodge Van, B1500		

PC	PART NO.	YEARS	MAKE/MODEL	WGT LBS	IN
30	75140	78-80	Dodge Van, B200	41	30
		81-94	Dodge Van, B250		
		95-98	Dodge Van, B2500		
		78-80	Dodge Van, B300		
		81-94	Dodge Van, B350		
		95-98	Dodge Van, B3500		
		99-03	Dodge Van, Ram 1500		
		99-03	Dodge Van, Ram 2500		
		99-03	Dodge Van, Ram 3500		
59	75144	93-98	Toyota T100	48	45
53	75145	92-95	Toyota 4Runner	52	40
34	75148	03-07	Nissan Murano	32	30
11	75151	06-08	Dodge Ram 1500	14	20
		03	Dodge Ram 1500 (Built After 11/2002)		
		04-05	Dodge Ram 1500 Except Daytona/Hemi Sport Quad Cab/Ram Rumble Bee/SRT-10		
		03-09	Dodge Ram 2500		
03-09	Dodge Ram 3500				
36	75152	03-14	Volvo XC90	29	25
32	75153	04-06	Lexus RX330	37	20
		07-09	Lexus RX350		
		06-08	Lexus RX400h Hybrid		
		04-07	Toyota Highlander		
47	75155	03-09	Lexus GX470	31	35
03-09	Toyota 4Runner	31	35		
50	75156	04-05	Ford F-150	50	30
		06	Lincoln Mark LT (Built Before 8/2005)		
45	75158	04-07	Ford Freestar	33	30
		04-07	Mercury Monterey		
50	75159	04-09	Nissan Quest	47	20
18	75162	07-09	Chrysler Aspen	19	50
		04-09	Dodge Durango		
37	75163	04-05	Mitsubishi Endeavor	27	20
32	75172	03-06	Cadillac Escalade	31	30
		03-06	Cadillac Escalade ESV		
		03-06	Cadillac Escalade EXT		
58	75174	04-09	Cadillac SRX Except w/Sport Package Fascia	56	60
41	75186	88-94	Nissan D21	43	30
		98-04	Nissan Frontier		
		95-97	Nissan Pickup		
20	75189	96-14	Chevrolet Express 1500	39	15
		96-19	Chevrolet Express 2500		
		96-19	Chevrolet Express 3500		
		96-14	GMC Savana 1500		
		96-17	GMC Savana 2500		
		96-17	GMC Savana 3500		
28	75193	97-06	Jeep TJ (Canada Only)	31	15
97-06	Jeep Wrangler	31	15		
48	75210	03-06	Dodge Sprinter 2500 w/41" Wide Frames, Except 118" Wheelbase & Factory Metal Step Platform	45	20
		03-06	Dodge Sprinter 3500 w/41" Wide Frames, Except 118" Wheelbase & Factory Metal Step Platform		
		03-06	Freightliner Sprinter 2500 w/41" Wide Frames, Except 118" Wheelbase & Factory Metal Step Platform		
03-06	Freightliner Sprinter 3500 w/41" Wide Frames, Except 118" Wheelbase & Factory Metal Step Platform	20			
28	75214	15-18	Ford Edge Except Sport & Titanium Models	33	30
		19	Ford Edge Except Titanium Models		
		15	Ford Edge Titanium Model Only		
45	75216	15-19	Ford F-150	42	30
40	75218	13-18	Audi Q3	40	50
37	75219	15-17	RAM ProMaster City	30	60
35	75220†	13-15	Isuzu MU-X	43	45
36	75223	17	Infiniti QX30 Except Sport Model	34	90
		15-19	Mercedes-Benz GLA250		
37	75225	14-19	Acura MDX Except w/Full Size Spare Tire	40	20
16-19	Honda Pilot	40	20		
25	75227	12-19	Land Rover Range Rover Evoque Excluding Autobiography	31	45
41	75229	15-17	Land Rover Range Rover Sport	35	45
39	75232	11-18	RAM 1500	39	40
		19	RAM 1500 (Classic)		
35	75234	15-18	Ford Edge Except Sport & Titanium Models	35	45
		19	Ford Edge Except Titanium Models		
		15-18	Ford Edge Titanium and Sport Models Only		

CLASS III/IV RECEIVER HITCH INDEX

PC	PART NO.	YEARS	MAKE/MODEL	WGT LBS	IN		
19	75528	08-17	Buick Enclave	24	25		
		09-17	Chevrolet Traverse				
		07-16	GMC Acadia				
		17	GMC Acadia Limited				
		07-09	Saturn Outlook				
29	75529	07-09	Suzuki XL-7	26	30		
37	75531	07-15	Mazda CX-9	27	15		
53	75532	07-12	Hyundai Veracruz	51	30		
26	75540	16-19	Lexus RX350	31	20		
		16-19	Lexus RX450h				
34	75547	07-11	Honda CR-V	33	25		
53	75549	07-09	Dodge Sprinter 2500 144" & 170" Wheelbase, Except w/Factory Step Bumper	40	20		
		07-09	Dodge Sprinter 3500 144" & 170" Wheelbase, Except w/Factory Step Bumper				
		07-13	Freightliner Sprinter 2500 144" & 170" Wheelbase, Except w/Factory Step Bumper				
		07-13	Freightliner Sprinter 3500 144" & 170" Wheelbase, Except w/Factory Step Bumper				
		07-17	Mercedes-Benz Sprinter 144" & 170" Wheelbase, Except w/Factory Step Bumper				
		10-19	Mercedes-Benz Sprinter 2500 144" & 170" Wheelbase, Except w/Factory Step Bumper				
		10-19	Mercedes-Benz Sprinter 3500 144" & 170" Wheelbase, Except w/Factory Step Bumper				
		01-10	Chevrolet Silverado 2500 HD			40	20
		03-07	Chevrolet Silverado 2500 HD (Classic)				
		01-02	Chevrolet Silverado 3500				
03-07	Chevrolet Silverado 3500 (Classic)						
07-10	Chevrolet Silverado 3500 HD						
01-10	GMC Sierra 2500 HD						
03-07	GMC Sierra 2500 HD (Classic)						
01-02	GMC Sierra 3500						
03-07	GMC Sierra 3500 (Classic)						
07-10	GMC Sierra 3500 HD						
45	75551	07-10	KIA Sedona 113.8" Short Wheelbase	41	25		
44	75555	07-10	Mitsubishi Outlander	39	25		
		11-13	Mitsubishi Outlander Except Outlander Sport				
30	75556	12-15	Chevrolet Captiva Sport	32	15		
		08-09	Saturn Vue				
40	75560	08-09	Subaru Legacy Sedan	25	25		
		05-07	Subaru Legacy Sedan, Except Outback				
		05-07	Subaru Legacy Wagon, Except Outback				
		05-07	Subaru Outback Sedan, Except Sport				
		05-09	Subaru Outback Wagon, Except Sport				
30	75561	05-09	Hyundai Tucson	29	25		
		05-10	KIA Sportage 4 Cyl.				
		05-10	KIA Sportage 6 Cyl.				
33	75563	07-09	Acura RDX	27	30		
36	75578	08-12	Jeep Liberty	36	20		
19	75579	08-16	Chrysler Town & Country	45	20		
		08-19	Dodge Grand Caravan				
		12-15	RAM C/V Tradesman				
		09-12	Volkswagen Routan				
		13-14	Volkswagen Routan (Canada Only)				
35	75586	08-13	Toyota Highlander Except w/Full Size 19" Spare Tire	45	25		
31	75599	01-06	Acura MDX Except w/Full Size Spare Tire	40	30		
		03-08	Honda Pilot				
51	75600	07-18	BMW X5 Except M Sport Package	41	75		
52	75601	07-09	Dodge Sprinter 2500 w/Factory Step Bumper Excluding Models w/30-3/8" Frame Width	50	30		
		07-09	Dodge Sprinter 3500 w/Factory Step Bumper Excluding Models w/30-3/8" Frame Width				
		07-13	Freightliner Sprinter 2500 w/Factory Step Bumper Excluding Models w/30-3/8" Frame Width				
		07-13	Freightliner Sprinter 3500 w/Factory Step Bumper Excluding Models w/30-3/8" Frame Width				
		10-19	Mercedes-Benz Sprinter 2500 w/Factory Step Bumper Excluding Models w/30-3/8" Frame Width				
		10-19	Mercedes-Benz Sprinter 3500 w/Factory Step Bumper Excluding Models w/30-3/8" Frame Width				
		07-17	Mercedes-Benz Sprinter w/Factory Step Bumper Excluding Models w/30-3/8" Frame Width				
		04-12	Chevrolet Colorado			33	25
		04-12	GMC Canyon				
		06	Isuzu i-280				

PC	PART NO.	YEARS	MAKE/MODEL	WGT LBS	IN
23	75607	07-08	Isuzu i-290	33	25
		06	Isuzu i-350		
		07-08	Isuzu i-370		
47	75614	07-13	Acura MDX Except w/Full Size Spare Tire or w/Rear Sport Bumper Option	29	35
35	75644	08-14	Nissan Armada	39	15
30	75647	09-14	Nissan Murano Except w/Aero Kit & CrossCabriolet	28	35
29	75648	09-10	Dodge Journey	28	25
		12-19	Dodge Journey Except w/LED Taillights		
		11-19	Dodge Journey w/LED Taillights		
19	75649	08-19	Toyota Sequoia	21	40
27	75650	09-13	Subaru Forester	36	35
10	75658	09-17	Volkswagen Tiguan	9	20
40	75659	03-04	Honda Element	23	30
		05-11	Honda Element Except SC		
		05-10	Honda Element SC		
		06-10	Dodge Ram 1500		
11	75662	03	Dodge Ram 1500 (Built After 11/2002)	16	20
		04-05	Dodge Ram 1500 Except Daytona/Hemi Sport Quad Cab/Ram Rumble Bee/SRT-10		
		03-09	Dodge Ram 2500		
		03-09	Dodge Ram 3500		
		11-18	RAM 1500		
38	75663	09-16	Toyota Venza	39	20
45	75670	10-19	Ford Taurus 4 Dr. Sedan	42	30
33	75671	10-17	Volvo XC60	30	45
30	75673	10-19	Subaru Legacy Sedan	37	45
		10-19	Subaru Outback Wagon, Except Sport		
29	75676	10-15	Lexus RX350 Except F Sport	30	30
		10-15	Lexus RX450h Hybrid		
33	75678	10-13	Ford Transit Connect	30	20
45	75679	09-19	Ford Flex	37	30
		10-17	Lincoln MKT		
28	75682	10-16	Cadillac SRX	22	15
25	75684	10-12	Hyundai Santa Fe	46	15
		11-13	KIA Sorento Base I4		
		11-13	KIA Sorento EX I4		
		11-13	KIA Sorento EX V6, Except w/Factory Tow Package		
		11-13	KIA Sorento EX V6, w/Factory Tow Package		
		11-13	KIA Sorento LX I4		
		11-13	KIA Sorento LX V6		
21	75685	10-19	Lexus GX460	9	15
37	75686	09-10	Ford Edge Sport	29	45
23	75688	08-14	Land Rover LR2	24	20
33	75690	02-06	Honda CR-V	37	30
19	75691	09-14	Ford F-150	37	20
21	75699	11-13	Jeep Grand Cherokee Except w/OEM Tow Hook	32	20
		14-19	Jeep Grand Cherokee Except w/OEM Tow Hook or ECODiesel Engine		
		11-13	Jeep Grand Cherokee w/OEM Tow Hook		
		14-19	Jeep Grand Cherokee w/OEM Tow Hook, Except w/ECODiesel Engine		
19	75703	75-83	Ford E-100 Econoline	33	20
		75-14	Ford E-150 Econoline		
		75-14	Ford E-250 Econoline		
		75-02	Ford E-350 Econoline		
		03-14	Ford E-350 Econoline Super Duty		
43	75707	11-14	Chevrolet Silverado 2500 HD	51	20
		11-14	Chevrolet Silverado 3500 HD		
		11-14	GMC Sierra 2500 HD		
		11-14	GMC Sierra 3500 HD		
23	75712	07-10	Jeep Compass	29	15
		11-17	Jeep Compass (Old Body Style)		
		07-10	Jeep Compass Rallye Edition		
		07-17	Jeep Patriot		
		07-17	Jeep Patriot		
25	75713	11-19	Dodge Durango	31	20
		14-19	Jeep Grand Cherokee EcoDiesel		
51	75714	11-16	Nissan Quest	46	35
28	75715	12-19	Nissan NV1500	42	20
		12-19	Nissan NV2500		
		12-19	Nissan NV3500		
35	75716	11-14	Subaru Tribeca	35	30
23	75717	10-15	Hyundai Tucson	32	20
		11-16	KIA Sportage		

CLASS III/IV RECEIVER HITCH INDEX

PC	PART NO.	YEARS	MAKE/MODEL	WGT LBS	IN				
29	75725	02	Cadillac Escalade	39	15				
		02	Cadillac Escalade EXT						
		02-06	Chevrolet Avalanche 1500						
		02-06	Chevrolet Avalanche 2500						
		00-06	Chevrolet Suburban 1500 w/Amber Turn Signals						
		00-06	Chevrolet Suburban 2500 w/Amber Turn Signals						
		00-06	Chevrolet Tahoe w/Amber Turn Signals						
		01-02	GMC Yukon Denali w/Amber Turn Signals						
		00-06	GMC Yukon w/Amber Turn Signals						
		00-06	GMC Yukon XL 1500						
		01-02	GMC Yukon XL 1500 Denali						
		00-06	GMC Yukon XL 2500						
45	75726	08-13	Toyota Highlander	48	40				
35	75728	11-14	Ford Edge Sport	34	45				
53	75730	08-14	Toyota Hilux	44	60				
27	75740	97-03	Ford F-150 Flareside	37	20				
		04	Ford F-150 Heritage Flareside						
		04	Ford F-150 Heritage Styleside						
		97-03	Ford F-150 Styleside						
		00-03	Ford F-150 SuperCrew						
		97-99	Ford F-250 Styleside						
		99-07	Ford F-250 Super Duty Except Cab & Chassis						
		99-07	Ford F-350 Super Duty Except Cab & Chassis						
		38	75741			04-10	Infiniti QX56	35	15
						05-07	Nissan Armada		
04	Nissan Pathfinder Armada								
16	75742	12-16	Honda CR-V	28	40				
35	75748†	13-15	Mazda CX-5	39	40				
34	75751	05-12	Ford Escape	35	25				
		05-11	Mazda Tribute						
		05-11	Mercury Mariner						
40	75758	13-19	Ford Escape	41	15				
33	75761	13-15	BMW X1 w/Panoramic Moonroof	31	60				
36	75768†	11-17	BMW X3	27	90				
28	75772	13-18	Hyundai Santa Fe Sport (5 Passenger)	37	30				
		14-15	KIA Sorento w/ I4 Engine						
		14-15	KIA Sorento w/ V6 Engine						
56	75774	10-15	Mercedes-Benz GLK350	37	20				
33	75776	13-18	Hyundai Santa Fe (6/7 Passenger)	32	30				
38	75778	09-12	Infiniti FX35	40	40				
		13	Infiniti FX37						
		09-13	Infiniti FX50						
		14-19	Infiniti QX70						
		13-19	Ford Escape						
19	75784	10-18	Acura RDX	28	30				
54	75790	13-16	Ford Ranger	25	30				
38	75791	16-17	Toyota Hilux	46	45				
51	75792	13	Isuzu D-Max	33	20				
59	75808†	13	Volkswagen Amarok (International Only)	36	30				
51	75810†	13	Chevrolet S10	42	30				
28	75836	16-18	Hyundai Tucson	28	30				
35	75838	14-15	Jeep Cherokee Trailhawk	38	30				
32	75852	14-19	Ford Transit Connect	34	15				
33	75866	14-19	Chevrolet Silverado 1500 LD (Old Body Style)	47	20				
		14-19	GMC Sierra 1500 LD (Old Body Style)						
54	75874†	12-15	Mercedes-Benz ML350 Except BlueTEC & w/Active Curve System	24	30				
21	75876	14-18	Subaru Forester	35	25				
56	75882	14-19	RAM ProMaster 1500 Except w/Extended Body	51	45				
		14-19	RAM ProMaster 2500 Except w/Extended Body						
		14-19	RAM ProMaster 3500 Except w/Extended Body						
36	75888	14-15	Mitsubishi Outlander Except Outlander Sport	42	30				
		16-19	Mitsubishi Outlander Except Outlander Sport Except Outlander Sport or PHEV						
40	75894	15-19	KIA Sedona	45	20				
36	75896	18	Lexus RX350L	45	30				
		14-19	Toyota Highlander						
31	75898	15-17	Chevrolet City Express	35	30				
		13-17	Nissan NV200						
23	75902	08-13	Nissan Rogue Except Krom	32	15				
		14-19	Nissan Rogue Except Sport						
		14	Nissan Rogue Select						
38	75904	14	Toyota Prado	37	15				
42	75906	15-19	Chevrolet Silverado 2500 HD	54	30				
		15-17	Chevrolet Silverado 3500 HD						
		15-19	GMC Sierra 2500 HD						
		15-17	GMC Sierra 3500 HD						

PC	PART NO.	YEARS	MAKE/MODEL	WGT LBS	IN
36	75908	19	Hyundai Santa Fe	38	40
		16-19	KIA Sorento w/ I4 Engine		
		16-19	KIA Sorento w/ V6 Engine		
27	75912	15-19	Ford Transit-150 Except Cab & Chassis and the Cutaway	30	25
		15-19	Ford Transit-250 Except Cab & Chassis and the Cutaway		
		15-19	Ford Transit-350 Except Single Rear Wheel w/148" Wheelbase or Cab & Chassis and the Cutaway		
		15-19	Ford Transit-350 Single Rear Wheel w/148" Wheelbase, Except Cab & Chassis and the Cutaway		
38	75914	14	Toyota Hilux SW4	38	15
27	75916	11-18	Volvo S60 Sedan	32	70
		15-17	Volvo V60 (App. starts with 2015-1/2)		
		08-10	Volvo V70 Wagon		
		08-16	Volvo XC70		
27	75938	15-19	Ford F-150	36	30
34	75940	11-17	Audi Q5	43	60
		15-17	Porsche Macan		
34	75943	15-19	Lincoln MKC	44	45
34	75948	15-19	Chevrolet Colorado	35	35
		15-19	GMC Canyon		
45	75950	07-16	Audi Q7	51	70
		11-18	Porsche Cayenne		
		11-17	Volkswagen Touareg		
28	75952	15-19	Nissan Murano	34	15
29	75956	15-17	Lexus NX200t	37	35
20	75992	07-14	Ford Edge Except Sport	30	55
		07-15	Lincoln MKX		
30	75998	14-19	Jeep Cherokee	39	60
30	76004	15-19	Chevrolet Colorado	46	35
		15-19	GMC Canyon		
34	76014†	16-19	Volvo XC90	39	90
32	76015	16-19	Mercedes-Benz Metris	41	20
25	76016	14-19	Chevrolet Silverado 1500 LD (Old Body Style)	46	25
		14-19	GMC Sierra 1500 LD (Old Body Style)		
25	76018	16-19	BMW X1	37	40
26	76019	16-19	FIAT 500X	36	30
24	76020	16-19	Mazda CX-9	38	30
26	76021	15-18	Jeep Renegade	37	40
23	76022	17-19	Cadillac XT5 Except Platinum	34	20
24	76023	20	Cadillac XT6	32	90
		19	Chevrolet Blazer		
		17-19	GMC Acadia		
31	76025	11-17	Honda Odyssey	42	80
37	76026	17-19	Jaguar F-Pace	40	90
14	76028	05-17	Chevrolet Equinox	33	30
		10-17	GMC Terrain		
		06-09	Pontiac Torrent		
		02-07	Saturn Vue Except Redline		
25	76031	13	Infiniti JX35	35	25
		14-19	Infiniti QX60		
		13-19	Nissan Pathfinder		
19	76034	11-19	Ford Explorer	29	45
28	76046	17-19	Chrysler Pacifica Hybrid (Needs Conversion Kit: 76046SK)	44	45
		17-19	Chrysler Pacifica Limited		
		17-19	Chrysler Pacifica LX		
		17-19	Chrysler Pacifica Touring		
		17-19	Chrysler Pacifica Touring L		
		17-19	Chrysler Pacifica Touring L Plus		
		17-19	Chrysler Pacifica Touring Plus		
		14-19	RAM ProMaster 1500 All Models		
14-19	RAM ProMaster 2500 All Models				
29	76074	17-19	KIA Sportage Except SX & SX Turbo	36	25
34	76076	17-18	Audi Q7	40	60
38	76078	16-17	Nissan NP300 Navara International Only	40	30
24	76080	16-18	Buick Envision	28	45
27	76082	16-19	Mercedes-Benz GLC300 SUV, Except P03 Premium Package	37	65
		16-19	Mercedes-Benz GLC300 SUV, with P03 Premium Package		
24	76084	16-17	Subaru Crosstrek Except Hybrid	36	20
		16-17	Subaru Crosstrek Hybrid		
		13-15	Subaru XV Crosstrek Except Hybrid		
25	76098	11-19	Mitsubishi Outlander Sport Except PHEV	34	20
		11-17	Mitsubishi RVR (Canada Only)		

CLASS III/IV RECEIVER HITCH INDEX

PC	PART NO.	YEARS	MAKE/MODEL	WGT LBS	IN
11	76104	07-17	Jeep Wrangler Except w/Right Hand Drive	16	20
		18	Jeep Wrangler JK Except w/Right Hand Drive		20
		18	Jeep Wrangler JK Right Hand Drive		20
		18-19	Jeep Wrangler JL (New Body Style)		20
		07-17	Jeep Wrangler Right Hand Drive		20
32	76112	11-14	Toyota Sienna	42	60
		15-20	Toyota Sienna Except SE		60
		15-20	Toyota Sienna SE		60
33	76114	15-16	Mitsubishi L200 w/Factory Step Bumper	36	45
		15-16	Mitsubishi Triton w/Factory Step Bumper		45
25	76116	14-17	Volvo XC60	30	30
16	76128	17-19	Honda CR-V	28	20
26	76134	13-18	Toyota RAV4	38	20
		13-18	Toyota RAV4		45
29	76136	15-19	Ford F-150	41	30
24	76138	13-19	Mazda CX-5	33	20
52	76141	16-19	Mercedes-Benz GLE350 Except w/Active Curve System	43	40
		12-15	Mercedes-Benz ML350 Except w/Active Curve System		40
40	76143	16-17	Tesla X	41	75
26	76144	17-19	Jeep Compass (New Body Style)	30	40
23	76145	05-19	Chrysler 300	35	40
		05-19	Chrysler 300		30
		08-19	Dodge Challenger Except Models w/Quad Tip Exhaust		30
		06-19	Dodge Charger		30
		05-08	Dodge Magnum		30
40	76154	17	Nissan Titan Except Titan XD or Models w/ Factory 7-Way Wiring	43	30
		17	Nissan Titan w/ Factory 7-Way Wiring Except Titan XD		30
42	76156	18	Lexus RX350L	46	30
		14-19	Toyota Highlander		45
32	76170	18-19	Honda Odyssey With Fuse Provisions	46	80
		18-19	Honda Odyssey Without Fuse Provisions		80
27	76171	18-19	Honda Odyssey With Fuse Provisions	45	80
		18-19	Honda Odyssey Without Fuse Provisions		80
31	76176	18-19	Volkswagen Atlas	53	25
26	76177	17	Nissan Qashqai	36	45
		17-19	Nissan Rogue Sport		45
34	76182	14-18	Subaru Forester	35	60
34	76183	18-19	Audi Q5	31	90
		18	Audi SQ5		90
30	76184	18-19	Buick Enclave	42	75
		18-19	Chevrolet Traverse		75
30	76190	16-19	Volvo XC90	37	45
26	76192	18-19	Volkswagen Tiguan 4 Motion	37	40
		18-19	Volkswagen Tiguan Except 4 Motion		40
30	76194	18-19	Volvo XC60	35	65
		16-19	Volvo XC90		65
31	76196	11-19	Dodge Durango	31	90
47	76199	18	Alfa Romeo Stelvio Except Quadrifoglio	35	80
35	76200	18	BMW X2	32	80
29	76201	19	Toyota RAV4	43	35
26	76209	18-19	Subaru Crosstrek Except Hybrid	36	60
		18-19	Subaru Crosstrek Hybrid		60
		18-19	Subaru Impreza 5 Dr. Wagon, Except WRX STI & w/Quad Exhaust Outlets		60
28	76217	18-20	Chevrolet Equinox Diesel	34	70
		18-19	GMC Terrain Diesel		70
33	76225	09-10	Dodge Journey	42	90
		12-19	Dodge Journey Except w/LED Taillights		90
		11-19	Dodge Journey w/LED Taillights		90
36	76226	11-19	BMW X3	27	75
35	76227	10-19	Subaru Outback Wagon, Except Sport	35	45
35	76240	19	Infiniti QX50	25	20
40	76244	18-19	Mitsubishi Eclipse Cross	34	20
28	76245	19	Volvo XC40	17	70
35	76253	19	Subaru Ascent	35	60
42	76260	18-19	Land Rover Range Rover Velar	27	80
22	76266	19	Cadillac XT4	28	80
19	76268	19-20	Acura RDX With +12V Power Provision	26	25
		19-20	Acura RDX Without +12V Power Provision		25
21	76271	19	Subaru Forester	32	30
18	76275	19	Ford Ranger	36	20
51	76288	19	BMW X5 Except M Sport Package	38	90
41	76290	19	Honda Passport	43	20
24	76300	19	Buick Envision	23	25
28	76320	20	Ford Explorer	43	40

PC	PART NO.	YEARS	MAKE/MODEL	WGT LBS	IN
33	76330	18-19	Jaguar E-Pace	20	90
38	76403	20	Hyundai Palisade	40	30
		20	KIA Telluride		30
23	76419	18-20	Chevrolet Equinox Except Premier or Models w/1.6L Diesel	42	35
		18-20	Chevrolet Equinox Premier, Except Models w/1.6L Diesel		35
		18-19	GMC Terrain Except Diesel		35
CLASS III/IV: MULTI-FIT					
54	37130	88-99	Chevrolet C1500	62	40
		92-00	Chevrolet C2500 Crew Cab		40
		88-99	Chevrolet C2500 Regular & Extended Cabs		40
		92-00	Chevrolet C3500 Crew Cab		40
		88-00	Chevrolet C3500 Regular & Extended Cabs		40
		88-99	Chevrolet K1500		40
		92-00	Chevrolet K2500 Crew Cab		40
		88-99	Chevrolet K2500 Regular & Extended Cabs		40
		92-00	Chevrolet K3500 Crew Cab		40
		88-00	Chevrolet K3500 Regular & Extended Cabs		40
		99-02	Chevrolet Silverado 1500		25
		03-07	Chevrolet Silverado 1500 (Classic)		25
		01-03	Chevrolet Silverado 1500 HD		25
		05-07	Chevrolet Silverado 1500 HD (Classic)		25
		99-04	Chevrolet Silverado 2500		25
		71-89	Dodge D100		25
		77-93	Dodge D150		25
		71-80	Dodge D200		25
		81-93	Dodge D250		25
		71-80	Dodge D300		25
		86-93	Dodge D350		25
		94-01	Dodge Ram 1500		40
		94-02	Dodge Ram 2500		40
		94-02	Dodge Ram 3500		40
		71-89	Dodge W100		25
		77-93	Dodge W150		25
		71-80	Dodge W200		25
		81-85	Dodge W250		25
		71-80	Dodge W300		25
		81-93	Dodge W350		25
		75-79	Ford F-100		35
		80-83	Ford F-100 Except w/Custom Fascia		35
		75-96	Ford F-150		35
		80-86	Ford F-150 Except w/Custom Fascia		35
		97-03	Ford F-150 Flareside		25
		04	Ford F-150 Heritage Flareside		25
		04	Ford F-150 Heritage Styleside		25
		97-03	Ford F-150 Styleside		25
		00-03	Ford F-150 SuperCrew		25
		75-96	Ford F-250		35
		80-86	Ford F-250 Except w/Custom Fascia		35
		97	Ford F-250 Heavy Duty		35
		97-99	Ford F-250 Styleside		25
		99-04	Ford F-250 Super Duty Except Cab & Chassis		30
		75-96	Ford F-350		35
		80-86	Ford F-350 Except w/Custom Fascia		35
		97	Ford F-350 Heavy Duty		35
99-04	Ford F-350 Super Duty Except Cab & Chassis		30		
88-99	GMC C1500		40		
88-00	GMC C2500		40		
88-00	GMC C3500		40		
88-99	GMC K1500		40		
88-00	GMC K2500		40		
88-00	GMC K3500		40		
99-02	GMC Sierra 1500		25		
03-07	GMC Sierra 1500 (Classic)		25		
01-03	GMC Sierra 1500 HD		25		
05-07	GMC Sierra 1500 HD (Classic)		25		
99-04	GMC Sierra 2500		25		
00-06	Toyota Tundra		30		
49	37133	88-99	Chevrolet C1500	57	40
		92-00	Chevrolet C2500 Crew Cab		40
		88-99	Chevrolet C2500 Regular & Extended Cabs		40
		92-00	Chevrolet C3500 Crew Cab		40
		88-00	Chevrolet C3500 Regular & Extended Cabs		40
		88-99	Chevrolet K1500		40
		92-00	Chevrolet K2500 Crew Cab		40
		88-99	Chevrolet K2500 Regular & Extended Cabs		40

CLASS III/IV RECEIVER HITCH INDEX

PC	PART NO.	YEARS	MAKE/MODEL	WGT			
				LBS	IN		
49	37133	92-00	Chevrolet K3500 Crew Cab	57	40		
		88-00	Chevrolet K3500 Regular & Extended Cabs		40		
		99-02	Chevrolet Silverado 1500		25		
		03-07	Chevrolet Silverado 1500 (Classic)		25		
		01-03	Chevrolet Silverado 1500 HD		25		
		05-07	Chevrolet Silverado 1500 HD (Classic)		25		
		99-04	Chevrolet Silverado 2500		25		
		71-89	Dodge D100		25		
		77-93	Dodge D150		25		
		71-80	Dodge D200		25		
		81-93	Dodge D250		25		
		71-80	Dodge D300		25		
		81-93	Dodge D350		25		
		94-01	Dodge Ram 1500		40		
		94-02	Dodge Ram 2500		40		
		94-02	Dodge Ram 3500		40		
		71-89	Dodge W100		25		
		77-93	Dodge W150		25		
		71-80	Dodge W200		25		
		81-93	Dodge W250		25		
		71-80	Dodge W300		25		
		81-93	Dodge W350		25		
		75-79	Ford F-100		35		
		80-83	Ford F-100 Except w/Custom Fascia		35		
		75-05	Ford F-150		45		
		75-05	Ford F-150		35		
		80-86	Ford F-150 Except w/Custom Fascia		35		
		97-03	Ford F-150 Flareside		25		
		04	Ford F-150 Heritage Flareside		25		
		04	Ford F-150 Heritage Styleside		25		
		97-03	Ford F-150 Styleside		25		
		00-03	Ford F-150 SuperCrew		25		
		75-96	Ford F-250		35		
		80-86	Ford F-250 Except w/Custom Fascia		35		
		97	Ford F-250 Heavy Duty		35		
		97-99	Ford F-250 Styleside		25		
		99-04	Ford F-250 Super Duty Except Cab & Chassis		30		
		75-96	Ford F-350		35		
		80-86	Ford F-350 Except w/Custom Fascia		35		
		97	Ford F-350 Heavy Duty		35		
		99-04	Ford F-350 Super Duty Except Cab & Chassis		30		
		88-99	GMC C1500		40		
		88-00	GMC C2500		40		
		88-00	GMC C3500		40		
		88-99	GMC K1500		40		
		88-00	GMC K2500		40		
		88-00	GMC K3500		40		
		99-02	GMC Sierra 1500		25		
		03-07	GMC Sierra 1500 (Classic)		25		
		01-03	GMC Sierra 1500 HD		25		
		05-07	GMC Sierra 1500 HD (Classic)		25		
		99-04	GMC Sierra 2500		25		
		00-06	Toyota Tundra		35		
		50	37136	90-05	Chevrolet Astro Extended Body	60	65
				92-94	Chevrolet Blazer Full Size		30
				96-14	Chevrolet Express 1500		30
				96-19	Chevrolet Express 2500		30
				96-19	Chevrolet Express 3500		30
				98-04	Chevrolet S10		30
				83-97	Chevrolet S10 w/Standard Bed & Step Bumper		30
				00-06	Chevrolet Suburban 1500 w/Amber Turn Signals		30
00-06	Chevrolet Suburban 2500 w/Amber Turn Signals				30		
92-99	Chevrolet Suburban C1500				30		
92-99	Chevrolet Suburban C2500				30		
92-99	Chevrolet Suburban K1500				30		
92-99	Chevrolet Suburban K2500				30		
95-00	Chevrolet Tahoe				30		
00-06	Chevrolet Tahoe w/Amber Turn Signals				30		
96-03	Chrysler Town & Country				40		
90-95	Chrysler Town & Country 2 WD Long Wheelbase				40		
04-07	Chrysler Town & Country Except w/Stow & Go Seats				40		
01-03	Chrysler Voyager				40		
96-03	Dodge Caravan				40		
91-95	Dodge Caravan C/V Short Wheelbase, 2 WD				30		
04-07	Dodge Caravan Except w/Stow & Go Seats				40		
84-95	Dodge Caravan Short Wheelbase, 2 WD				40		
87-01	Dodge Dakota				35		

PC	PART NO.	YEARS	MAKE/MODEL	WGT	
				LBS	IN
50	37136	02-04	Dodge Dakota Except Quad Cab	60	35
		96-03	Dodge Grand Caravan		40
		04-07	Dodge Grand Caravan Except w/Stow & Go Seats		40
		87-93	Dodge Grand Caravan Long Wheelbase, 2 WD		30
		94-95	Dodge Grand Caravan Long Wheelbase, 2 WD, Except LE		30
		82-93	Dodge Ramcharger		30
		86-97	Ford Aerostar Extended Body		40
		82-96	Ford Bronco		30
		84-90	Ford Bronco II		30
		01-04	Ford Escape		60
		98-11	Ford Ranger Except Flareside or w/Rear Fascia		40
		83-97	Ford Ranger Except w/Rear Fascia		40
		03	Ford Windstar (Built After 11/2002)		40
		99-03	Ford Windstar (Built Before 11/2002)		40
		83-90	GMC S15 w/Standard Bed & Step Bumper		40
		90-05	GMC Safari Extended Body		65
		96-14	GMC Savana 1500		30
		96-17	GMC Savana 2500		30
		96-17	GMC Savana 3500		30
		98-04	GMC Sonoma		40
		92-99	GMC Suburban C1500		30
		92-99	GMC Suburban C2500		30
		92-99	GMC Suburban K1500		30
		92-99	GMC Suburban K2500		30
		92-00	GMC Yukon		30
		99-00	GMC Yukon Denali		30
		01-02	GMC Yukon Denali w/Amber Turn Signals		30
		00-06	GMC Yukon w/Amber Turn Signals		30
		00-06	GMC Yukon XL 1500		30
		01-02	GMC Yukon XL 1500 Denali		30
		00-06	GMC Yukon XL 2500		30
		98-00	Isuzu Hombre w/Step Bumper		40
		84-01	Jeep Cherokee		35
		84-01	Jeep Cherokee		45
		93-98	Jeep Grand Cherokee		35
		02-07	Jeep Liberty		35
		90-93	Mazda B2200		30
		94-09	Mazda B2300		40
		98-01	Mazda B2500		40
		90-93	Mazda B2600		30
		94-08	Mazda B3000		40
		94-09	Mazda B4000		40
		01-04	Mazda Tribute		60
		88-94	Nissan D21		30
		86-87	Nissan D21 (App. starts with 86-1/2)		30
		98-04	Nissan Frontier		35
		95-97	Nissan Pickup		30
		87-00	Plymouth Grand Voyager		30
		87-00	Plymouth Grand Voyager		40
		91-95	Plymouth Grand Voyager Long Wheelbase, 2 WD		30
84-00	Plymouth Voyager		30		
84-00	Plymouth Voyager		40		
37	40050	63-86	Chevrolet C10	57	40
		88-99	Chevrolet C1500		40
		63-86	Chevrolet C20		40
		92-00	Chevrolet C2500 Crew Cab		40
		88-99	Chevrolet C2500 Regular & Extended Cabs		40
		63-86	Chevrolet C30		40
		88-00	Chevrolet C3500 Regular & Extended Cabs		40
		68-89	Dodge D100		40
		77-93	Dodge D150		40
		68-80	Dodge D200		40
		81-93	Dodge D250		40
		68-80	Dodge D300		40
		81-93	Dodge D350		40
		94-01	Dodge Ram 1500		40
		94-02	Dodge Ram 2500		40
		94-02	Dodge Ram 3500		40
		74-88	Dodge Ramcharger Except w/Skid Shield		40
		67-77	Dodge W100		40
		77-93	Dodge W150		40
		67-80	Dodge W200		40
81-93	Dodge W250		40		
67-80	Dodge W300		40		
81-93	Dodge W350		40		
78-96	Ford Bronco		40		

CLASS V RECEIVER HITCH INDEX

PC	PART NO.	YEARS	MAKE/MODEL	WGT			
				LBS	IN		
37	40050	89-97	Ford F Super Duty Cab & Chassis, w/34" Wide Frames & 161" Wheelbase	57	40		
		63-79	Ford F-100		40		
		80-83	Ford F-100 Except w/Custom Fascia		40		
		75-96	Ford F-150		40		
		80-86	Ford F-150 Except w/Custom Fascia		40		
		63-96	Ford F-250		40		
		80-86	Ford F-250 Except w/Custom Fascia		40		
		97	Ford F-250 Heavy Duty		40		
		63-96	Ford F-350		40		
		80-86	Ford F-350 Except w/Custom Fascia		40		
		97	Ford F-350 Heavy Duty		40		
		99-00	Ford F-350 Super Duty Cab & Chassis, w/34" Wide Frames		40		
		63-65	GMC 1000 Series		40		
		63-65	GMC 1500 Series		40		
		63-65	GMC 2500 Series		40		
		63-66	GMC 3000		40		
		63-66	GMC 3500		40		
		75-78	GMC C15		40		
		67-74	GMC C15/C1500		40		
		79-99	GMC C1500		40		
		67-78	GMC C25		40		
		79-00	GMC C2500		40		
		67-78	GMC C35		40		
		79-00	GMC C3500		40		
		74-81	Plymouth Trailduster Except w/Skid Shield		40		
		CLASS V: 2" RECEIVER					
		45	41901	88-99	Chevrolet C1500	73	30
92-00	Chevrolet C2500 Crew Cab				30		
88-00	Chevrolet C2500 Regular & Extended Cabs				30		
92-00	Chevrolet C3500 Crew Cab				30		
88-00	Chevrolet C3500 Regular & Extended Cabs				30		
88-99	Chevrolet K1500				30		
92-00	Chevrolet K2500 Crew Cab				30		
88-00	Chevrolet K2500 Regular & Extended Cabs				30		
92-00	Chevrolet K3500 Crew Cab				30		
88-00	Chevrolet K3500 Regular & Extended Cabs				30		
88-99	GMC C1500				30		
88-00	GMC C2500				30		
88-00	GMC C3500				30		
88-99	GMC K1500				30		
88-00	GMC K2500				30		
88-00	GMC K3500				30		
45	41902			68-89	Dodge D100	72	40
				77-93	Dodge D150		40
				68-80	Dodge D200		40
				81-93	Dodge D250		40
		71-80	Dodge D300		40		
		81-93	Dodge D350		40		
		67-89	Dodge W100		40		
		77-93	Dodge W150		40		
		67-80	Dodge W200		40		
		81-93	Dodge W250		40		
		67-80	Dodge W300		40		
81-93	Dodge W350		40				
42	41904	80-83	Ford F-100 Except w/Custom Fascia	75	30		
		87-96	Ford F-150		30		
		80-86	Ford F-150 Except w/Custom Fascia		30		
		87-96	Ford F-250		30		
		80-86	Ford F-250 Except w/Custom Fascia		30		
		97	Ford F-250 Heavy Duty		30		
		87-96	Ford F-350		30		
		80-86	Ford F-350 Except w/Custom Fascia		30		
		97	Ford F-350 Heavy Duty		30		
37	41906	92-14	Ford E-150 Econoline	56	30		
		92-14	Ford E-250 Econoline		30		
		92-02	Ford E-350 Econoline		30		
		03-14	Ford E-350 Econoline Super Duty		30		
59	41913	19	RAM 1500 (New Body Style)	85	60		
45	41920	97-03	Ford F-150 Flareside	70	30		
		04	Ford F-150 Heritage Flareside		30		
		04	Ford F-150 Heritage Styleside		30		
		97-03	Ford F-150 Styleside		30		
		00-03	Ford F-150 SuperCrew		30		
		97-99	Ford F-250 Styleside		30		
51	41922	99-04	Ford F-250 Super Duty Except Cab & Chassis	58	15		

PC	PART NO.	YEARS	MAKE/MODEL	WGT	
				LBS	IN
51	41922	99-04	Ford F-350 Super Duty Except Cab & Chassis	58	15
45	41923	94-01	Dodge Ram 1500	69	35
		94-02	Dodge Ram 2500		35
		94-02	Dodge Ram 3500		35
35	41926	00-14	Ford E-150 Econoline	51	30
		00-14	Ford E-250 Econoline		30
		00-02	Ford E-350 Econoline		30
		03-14	Ford E-350 Econoline Super Duty		30
37	41929	06-08	Dodge Ram 1500	70	35
		03	Dodge Ram 1500 (Built After 11/2002)		35
		04-05	Dodge Ram 1500 Except Daytona/Hemi Sport Quad Cab/Ram Rumble Bee/SRT-10		35
		03-10	Dodge Ram 2500		35
		03-10	Dodge Ram 3500		35
		11-18	RAM 2500		35
		11-18	RAM 3500		35
30	41930	00-06	Chevrolet Suburban 1500 w/Amber Turn Signals	59	35
		00-06	Chevrolet Suburban 2500 w/Amber Turn Signals		35
		00-06	GMC Yukon XL 1500		35
		01-02	GMC Yukon XL 1500 Denali		35
		00-06	GMC Yukon XL 2500		35
		55	41931	99-16	Ford F-250 Super Duty Except Cab & Chassis
		99-16	Ford F-350 Super Duty Except Cab & Chassis		30
50	41932	99-02	Chevrolet Silverado 1500	73	20
		03-07	Chevrolet Silverado 1500 (Classic)		20
		01-03	Chevrolet Silverado 1500 HD		20
		05-07	Chevrolet Silverado 1500 HD (Classic)		20
		99-04	Chevrolet Silverado 2500		20
		99-02	GMC Sierra 1500		20
		03-07	GMC Sierra 1500 (Classic)		20
		01-03	GMC Sierra 1500 HD		20
		05-07	GMC Sierra 1500 HD (Classic)		20
		99-04	GMC Sierra 2500		20
40	41933	06-08	Ford F-150	67	20
		06-08	Lincoln Mark LT (Built After 8/2005)		20
67	41935	07-19	Toyota Tundra (See Footnote CP)	84	30
29	41936	01-07	Chevrolet Silverado 3500 Cab & Chassis, w/34" Wide Frames (Classic)	55	30
		07-17	Chevrolet Silverado 3500 HD Cab & Chassis, w/34" Wide Frames		30
		07-10	Dodge Ram 3500 Cab & Chassis, w/34" Wide Frames		30
		08-10	Dodge Ram 4500 Cab & Chassis, w/34" Wide Frames		30
		08-10	Dodge Ram 5500 Cab & Chassis, w/34" Wide Frames		30
		01-07	GMC Sierra 3500 Cab & Chassis, w/34" Wide Frames (Classic)		30
		07-20	GMC Sierra 3500 HD Cab & Chassis, w/34" Wide Frames		30
		11-12	RAM 3500 Cab & Chassis, w/34" Wide Frames		30
		11-12	RAM 4500 Cab & Chassis, w/34" Wide Frames		30
		11-12	RAM 5500 Cab & Chassis, w/34" Wide Frames		30
		08-09	Sterling Truck Bullet 45 w/34" Wide Frames		30
		08-09	Sterling Truck Bullet 55 w/34" Wide Frames		30
		50	41938	63-84	Chevrolet C10
85-86	Chevrolet C10 w/34" Wide Frames				40
63-84	Chevrolet C20				40
85-86	Chevrolet C20 w/34" Wide Frames				40
88-91	Chevrolet C2500 Crew Cab				40
63-84	Chevrolet C30				40
85-86	Chevrolet C30 w/34" Wide Frames				40
88-91	Chevrolet C3500 Crew Cab				40
63-84	Chevrolet K10				40
85-86	Chevrolet K10 w/34" Wide Frames				40
63-84	Chevrolet K20				40
85-86	Chevrolet K20 w/34" Wide Frames				40
88-91	Chevrolet K2500 Crew Cab				40
73-84	Chevrolet K30				40
85-86	Chevrolet K30 w/34" Wide Frames				40
88-91	Chevrolet K3500 Crew Cab				40
01-07	Chevrolet Silverado 3500 Cab & Chassis, w/34" Wide Frames (Classic)				40
07-17	Chevrolet Silverado 3500 HD Cab & Chassis, w/34" Wide Frames		40		
99-00	Ford F-350 Super Duty Cab & Chassis, w/34" Wide Frames		40		
63-65	GMC 1000 Series		40		
63-65	GMC 1500 Series		40		
63-65	GMC 2500 Series		40		

CLASS V RECEIVER HITCH INDEX

PC	PART NO.	YEARS	MAKE/MODEL	WGT					
				LBS	IN				
50	41938	63-66	GMC 3000	73	40				
		63-66	GMC 3500						
		75-78	GMC C15						
		67-74	GMC C15/C1500						
		79-84	GMC C1500						
		85-99	GMC C1500 w/34" Wide Frames						
		67-78	GMC C25						
		79-84	GMC C2500						
		85-00	GMC C2500 w/34" Wide Frames						
		67-78	GMC C35						
		79-84	GMC C3500						
		85-00	GMC C3500 w/34" Wide Frames						
		67-78	GMC K15						
		79-84	GMC K1500						
		85-99	GMC K1500 w/34" Wide Frames						
		67-78	GMC K25						
		79-84	GMC K2500						
		85-00	GMC K2500 w/34" Wide Frames						
		68-78	GMC K35						
		79-84	GMC K3500						
		85-00	GMC K3500 w/34" Wide Frames						
		01-07	GMC Sierra 3500 Cab & Chassis, w/34" Wide Frames (Classic)						
		07-20	GMC Sierra 3500 HD Cab & Chassis, w/34" Wide Frames						
		50	41942			11-14	Chevrolet Silverado 2500 HD	67	20
						11-14	Chevrolet Silverado 3500 HD		
						11-14	GMC Sierra 2500 HD		
						11-14	GMC Sierra 3500 HD		
						11-14	GMC Sierra 3500 HD		
		70	41943			99-19	Ford F-350 Super Duty Cab & Chassis, w/34" Wide Frames	90	40
						99-19	Ford F-450 Super Duty Cab & Chassis, w/34" Wide Frames		
						99-19	Ford F-550 Super Duty Cab & Chassis, w/34" Wide Frames		
37	41944	01-10	Chevrolet Silverado 2500 HD	68	25				
		03-07	Chevrolet Silverado 2500 HD (Classic)						
		01-02	Chevrolet Silverado 3500						
		03-07	Chevrolet Silverado 3500 (Classic)						
		07-10	Chevrolet Silverado 3500 HD						
		01-10	GMC Sierra 2500 HD						
		03-07	GMC Sierra 2500 HD (Classic)						
		01-02	GMC Sierra 3500						
		03-07	GMC Sierra 3500 (Classic)						
		07-10	GMC Sierra 3500 HD						
		41	41945			00-14	Ford E-150 Econoline	44	30
00-14	Ford E-250 Econoline								
00-02	Ford E-350 Econoline								
03-14	Ford E-350 Econoline Super Duty								
42	41946	96-14	Chevrolet Express 1500	54	35				
		96-19	Chevrolet Express 2500						
		96-19	Chevrolet Express 3500						
		96-14	GMC Savana 1500						
		96-17	GMC Savana 2500						
		96-17	GMC Savana 3500						
55	41947	63-84	Chevrolet C10	80	35				
		85-86	Chevrolet C10 w/34" Wide Frames						
		63-84	Chevrolet C20						
		85-86	Chevrolet C20 w/34" Wide Frames						
		88-91	Chevrolet C2500 Crew Cab						
		63-84	Chevrolet C30						
		85-86	Chevrolet C30 w/34" Wide Frames						
		88-91	Chevrolet C3500 Crew Cab						
		63-84	Chevrolet K10						
		85-86	Chevrolet K10 w/34" Wide Frames						
		63-84	Chevrolet K20						
		85-86	Chevrolet K20 w/34" Wide Frames						
		88-91	Chevrolet K2500 Crew Cab						
		73-84	Chevrolet K30						
		85-86	Chevrolet K30 w/34" Wide Frames						
		88-91	Chevrolet K3500 Crew Cab						
		03-09	Chevrolet Kodiak C4500 Cab & Chassis, w/34" Wide Frames						
		03-09	Chevrolet Kodiak C5500 Cab & Chassis, w/34" Wide Frames						
		99-09	Chevrolet Kodiak C6500 Cab & Chassis, w/34" Wide Frames						

PC	PART NO.	YEARS	MAKE/MODEL	WGT	
				LBS	IN
55	41947	99-09	Chevrolet Kodiak C7500 Cab & Chassis, w/34" Wide Frames	80	35
		99-09	Chevrolet Kodiak C8500 Cab & Chassis, w/34" Wide Frames		
		01-07	Chevrolet Silverado 3500 Cab & Chassis, w/34" Wide Frames (Classic)		
		07-17	Chevrolet Silverado 3500 HD Cab & Chassis, w/34" Wide Frames		
		07-10	Dodge Ram 3500 Cab & Chassis, w/34" Wide Frames		
		08-10	Dodge Ram 4500 Cab & Chassis, w/34" Wide Frames		
		08-10	Dodge Ram 5500 Cab & Chassis, w/34" Wide Frames		
		99-19	Ford F-350 Super Duty Cab & Chassis, w/34" Wide Frames		
		99-19	Ford F-450 Super Duty Cab & Chassis, w/34" Wide Frames		
		99-19	Ford F-550 Super Duty Cab & Chassis, w/34" Wide Frames		
		63-65	GMC 1000 Series		
		63-65	GMC 1500 Series		
		63-65	GMC 2500 Series		
		63-66	GMC 3000		
		63-66	GMC 3500		
		75-78	GMC C15		
		67-74	GMC C15/C1500		
		79-84	GMC C1500		
		85-99	GMC C1500 w/34" Wide Frames		
		67-78	GMC C25		
		79-84	GMC C2500		
		85-00	GMC C2500 w/34" Wide Frames		
		67-78	GMC C35		
		79-84	GMC C3500		
		85-00	GMC C3500 w/34" Wide Frames		
		03-09	GMC C4500 Topkick Cab & Chassis, w/34" Wide Frames		
		03-09	GMC C5500 Topkick Cab & Chassis, w/34" Wide Frames		
		99-09	GMC C6500 Topkick Cab & Chassis, w/34" Wide Frames		
		99-09	GMC C7500 Topkick Cab & Chassis, w/34" Wide Frames		
		67-78	GMC K15		
		79-84	GMC K1500		
		85-99	GMC K1500 w/34" Wide Frames		
		67-78	GMC K25		
		79-84	GMC K2500		
		85-00	GMC K2500 w/34" Wide Frames		
68-78	GMC K35				
79-84	GMC K3500				
85-00	GMC K3500 w/34" Wide Frames				
01-07	GMC Sierra 3500 Cab & Chassis, w/34" Wide Frames (Classic)				
07-20	GMC Sierra 3500 HD Cab & Chassis, w/34" Wide Frames				
39	41948	11-18	RAM 1500	56	30
		19	RAM 1500 (Classic)		
53	41950	15-19	Chevrolet Silverado 2500 HD	72	60
		15-17	Chevrolet Silverado 3500 HD		
		15-19	GMC Sierra 2500 HD		
		15-17	GMC Sierra 3500 HD		
38	41952	13-17	RAM 4500 Cab & Chassis, w/34" Wide Frames	59	45
		13-17	RAM 5500 Cab & Chassis, w/34" Wide Frames		
CLASS V: 2-1/2" RECEIVER					
51	45502	87-96	Ford F-250	64	45
		80-86	Ford F-250 Except w/Custom Fascia		
		97	Ford F-250 Heavy Duty		
		87-96	Ford F-350		
		80-86	Ford F-350 Except w/Custom Fascia		
		97	Ford F-350 Heavy Duty		
47	45505	71-80	Dodge D200	68	45
		81-93	Dodge D250		
		71-80	Dodge D300		
		86-93	Dodge D350		
		94-98	Dodge Ram 2500		
		94-98	Dodge Ram 3500		
		71-80	Dodge W200		
		81-93	Dodge W250		

FRONT MOUNT RECEIVER HITCH INDEX

PC	PART NO.	YEARS	MAKE/MODEL	WGT LBS	IN
47	45505	71-80 81-93	Dodge W300 Dodge W350	68	45 45
59	45506	92-00 88-99 92-00 88-00 92-00 88-99 92-00 88-00 88-00 88-00 88-00	Chevrolet C2500 Crew Cab Chevrolet C2500 Regular & Extended Cabs Chevrolet C3500 Crew Cab Chevrolet C3500 Regular & Extended Cabs Chevrolet K2500 Crew Cab Chevrolet K2500 Regular & Extended Cabs Chevrolet K3500 Crew Cab Chevrolet K3500 Regular & Extended Cabs GMC C2500 GMC C3500 GMC K2500 GMC K3500	66	45 45 45 45 45 45 45 45 45 45 45
52	45507	96-19 96-19 96-17 96-17	Chevrolet Express 2500 Chevrolet Express 3500 GMC Savana 2500 GMC Savana 3500	58	45 45 45 45
60	45508	99-16 99-16 08-15	Ford F-250 Super Duty Except Cab & Chassis Ford F-350 Super Duty Except Cab & Chassis Ford F-450 Super Duty Except Cab & Chassis	92	50 50 50
66	45509	03-10 03-10 11-18 11-18	Dodge Ram 2500 Dodge Ram 3500 RAM 2500 RAM 3500	94	95 95 95 95
67	45510	11-14 11-14 11-14 11-14	Chevrolet Silverado 2500 HD Chevrolet Silverado 3500 HD GMC Sierra 2500 HD GMC Sierra 3500 HD	82	60 60 60 60
57	45511	15-19 15-17 15-19 15-17	Chevrolet Silverado 2500 HD Chevrolet Silverado 3500 HD GMC Sierra 2500 HD GMC Sierra 3500 HD	93	60 60 60 60
58	45512†	99-04 99-04	Chevrolet Silverado 2500 GMC Sierra 2500	71	20 20
54	45513	99-02 99-02	Dodge Ram 2500 Dodge Ram 3500	63	30 30
70	45514	99-04 99-04	Ford F-250 Super Duty w/Deep Drop Bumper Ford F-350 Super Duty w/Deep Drop Bumper	68	20 20
53	45515	00-02 00-06	Chevrolet Suburban 2500 w/Amber Turn Signals GMC Yukon XL 2500	59	50 50
65	45516	99-00 99-17 99-17	Ford F-350 Super Duty Cab & Chassis, w/34" Wide Frames Ford F-450 Super Duty Cab & Chassis, w/34" Wide Frames Ford F-550 Super Duty Cab & Chassis, w/34" Wide Frames	64	60 60 60
58	45517	01-10 03-07 01-02 03-07 07-10 01-10 03-07 01-02 03-07 07-10	Chevrolet Silverado 2500 HD Chevrolet Silverado 2500 HD (Classic) Chevrolet Silverado 3500 Chevrolet Silverado 3500 (Classic) Chevrolet Silverado 3500 HD GMC Sierra 2500 HD GMC Sierra 2500 HD (Classic) GMC Sierra 3500 GMC Sierra 3500 (Classic) GMC Sierra 3500 HD	64	25 25 25 25 25 25 25 25 25 25
63	45518	06-08 03 04-05 03-05 06-10 03-05 06-10 11-18 11-18	Dodge Ram 1500 Dodge Ram 1500 (Built After 11/2002) Dodge Ram 1500 Except Daytona/Hemi Sport Quad Cab/Ram Rumble Bee/SRT-10 Dodge Ram 2500 Dodge Ram 2500 Except Mega Cab Dodge Ram 3500 Dodge Ram 3500 Except Mega Cab RAM 2500 Except Mega Cab RAM 3500 Except Mega Cab	76	35 35 35 35 35 35 35 35 35
60	45519	01-10 03-07 01-02 03-07 07-10 01-10 07 01-02 03-07 07-10	Chevrolet Silverado 2500 HD 8 ft. Bed Chevrolet Silverado 2500 HD 8 ft. Bed (Classic) Chevrolet Silverado 3500 Chevrolet Silverado 3500 (Classic) Chevrolet Silverado 3500 HD GMC Sierra 2500 HD 8 ft. Bed GMC Sierra 2500 HD 8 ft. Bed (Classic) GMC Sierra 3500 GMC Sierra 3500 (Classic) GMC Sierra 3500 HD	77	25 25 25 25 25 25 25 25 25 25

PC	PART NO.	YEARS	MAKE/MODEL	WGT LBS	IN
FRONT MOUNT RECEIVER					
28	65001	91-07 91-07 91-07 03-07 00-02	Ford E-150 Econoline Ford E-250 Econoline Ford E-350 Econoline Inc. RV Cutaway Ford E-450 Econoline Super Duty RV Cutaway Ford E-450 Econoline Super Duty Stripped RV Cutaway	37	20 20 20 20 20
37	65003	94-01 94-02 94-02	Dodge Ram 1500 Dodge Ram 2500 Dodge Ram 3500	39	30 30 30
24	65004	95-05 99-01 94-04 95-05 94-04 96-00 96-01	Chevrolet Blazer Downsize Chevrolet Blazer Trailblazer Chevrolet S10 GMC Jimmy Downsize GMC Sonoma Isuzu Hombre Oldsmobile Bravada	33	30 30 30 30 30 30 30
21	65005	92-94 88-99 88-99 88-00 88-99 88-99 92-00 88-00 92-00 92-99 92-99 92-99 95-00 88-99 88-00 88-00 88-99 92-99 92-00 92-00 92-99 92-99 92-99 92-99 92-00	Chevrolet Blazer Full Size Chevrolet C1500 2 Dr. Regular & Extended Cabs Chevrolet C2500 2 Dr. Regular & Extended Cabs Chevrolet C3500 2 Dr. Regular & Extended Cabs Chevrolet K1500 2 Dr. Regular & Extended Cabs Chevrolet K2500 2 Dr. Regular & Extended Cabs Chevrolet K2500 4 Dr. Crew Cab Chevrolet K3500 2 Dr. Regular & Extended Cabs Chevrolet K3500 4 Dr. Crew Cab Chevrolet Suburban C1500 Chevrolet Suburban C2500 Chevrolet Suburban K1500 Chevrolet Suburban K2500 Chevrolet Tahoe GMC C1500 2 Dr. Regular & Extended Cabs GMC C2500 2 Dr. Regular & Extended Cabs GMC C3500 2 Dr. Regular & Extended Cabs GMC K1500 2 Dr. Regular & Extended Cabs GMC K1500 4 Dr. Crew Cab GMC K2500 4 Dr. Crew Cab GMC K3500 4 Dr. Crew Cab GMC Suburban C1500 GMC Suburban C2500 GMC Suburban K1500 GMC Suburban K2500 GMC Yukon	31	40 40
53	65008	93-98 93	Jeep Grand Cherokee Jeep Grand Wagoneer	44	25 25
23	65009	84-01 86-92 84-90	Jeep Cherokee Downsize Jeep Comanche Jeep Wagoneer	29	30 30 30
32	65014	92-97 92-97	Ford F-250 Styleside Ford F-350 Styleside	45	25 25
30	65015	92-97 92-97	Ford F-250 Ford F-350	36	25 25
24	65016	96-03 96-03 96-03 96-03 96-03 96-03	Chevrolet Express 1500 Inc. RV Cutaway Chevrolet Express 2500 Inc. RV Cutaway Chevrolet Express 3500 Inc. RV Cutaway GMC Savana 1500 Inc. RV Cutaway GMC Savana 2500 Inc. RV Cutaway GMC Savana 3500 Inc. RV Cutaway	35	35 35 35 35 35 35
52	65017	91-94 89-97 94-97 94-97 94-97 91-94	Ford Explorer Ford Ranger Mazda B2300 Mazda B3000 Mazda B4000 Mazda Navajo	34	35 35 35 35 35 35
46	65021†	88-99 92-99 88-99 92-00 88-00 92-00 92-99 92-99 92-99 92-99 88-99 92-99 88-00	Chevrolet C1500 2 Dr. Regular & Extended Cabs Chevrolet C1500 4 Dr. Crew Cab Chevrolet C2500 2 Dr. Regular & Extended Cabs Chevrolet C2500 4 Dr. Crew Cab Chevrolet C3500 2 Dr. Regular & Extended Cabs Chevrolet C3500 4 Dr. Crew Cab Chevrolet Suburban C1500 Chevrolet Suburban C2500 Chevrolet Suburban K1500 Chevrolet Suburban K2500 GMC C1500 2 Dr. Regular & Extended Cabs GMC C1500 4 Dr. Crew Cab GMC C2500 2 Dr. Regular & Extended Cabs	32	30 30 30 30 30 30 30 30 30 30 30 30 30

BRAKE CONTROL HARNESS INDEX

PC	PART NO.	YEARS	MAKE/MODEL	WGT LBS	IN				
46	65021f	92-00	GMC C2500 4 Dr. Crew Cab	32	30				
		88-00	GMC C3500 2 Dr. Regular & Extended Cabs						
		92-00	GMC C3500 4 Dr. Crew Cab						
		92-99	GMC Suburban C1500						
		92-99	GMC Suburban C2500						
		92-99	GMC Suburban K1500						
		92-99	GMC Suburban K2500						
34	65022	00-05	Ford Excursion	43	40				
		99-07	Ford F-250 Super Duty						
		99-07	Ford F-350 Super Duty						
		99-07	Ford F-350 Super Duty Cab & Chassis, w/34" Wide Frames						
		99-07	Ford F-450 Super Duty Cab & Chassis, w/34" Wide Frames						
		99-07	Ford F-550 Super Duty Cab & Chassis, w/34" Wide Frames						
47	65023	99-07	Chevrolet Silverado 1500	30	20				
		00-06	Chevrolet Suburban 1500						
		00-06	Chevrolet Tahoe 1500 Series						
		99-07	GMC Sierra 1500 Except Denali (Classic)						
		00-06	GMC Yukon 1500						
		01-06	GMC Yukon Denali 1500						
		00-06	GMC Yukon XL 1500						
		01-06	GMC Yukon XL 1500 Denali						
		31	65024			01-05	Ford Ranger	39	35
						02-05	Mazda B2300		
01	Mazda B2500								
01-05	Mazda B3000								
01-05	Mazda B4000								
35	65025	97-02	Ford Expedition	33	20				
		97-03	Ford F-150						
		04	Ford F-150 Heritage						
		97-99	Ford F-250 Styleside						
		98-02	Lincoln Navigator						
24	65028	01-07	Chevrolet Silverado 1500 HD	30	20				
		99-04	Chevrolet Silverado 2500						
		01-07	Chevrolet Silverado 2500 HD						
		01-07	Chevrolet Silverado 3500						
		00-06	Chevrolet Suburban 2500						
		01-07	GMC Sierra 1500 HD						
		99-04	GMC Sierra 2500						
		01-07	GMC Sierra 2500 HD						
		01-07	GMC Sierra 3500						
		00-06	GMC Yukon XL 2500						
42	65029f	00-04	Dodge Dakota 4 WD	44	25				
		00-03	Dodge Durango 4 WD						
29	65030f	01-03	Ford Explorer 2 Dr. Sport	21	25				
		01-05	Ford Explorer Sport Trac						
30	65031	01-07	Toyota Sequoia	41	40				
		00-06	Toyota Tundra						
32	65032f	02-05	Ford Explorer 4 Dr.	34	30				
		02-05	Mercury Mountaineer						
49	65033	02-05	Dodge Ram 1500	43	25				
		02-05	Dodge Ram 1500						
31	65041	01-04	Toyota Tacoma	31	30				
		01-04	Toyota Tacoma						
22	65043	04-08	Ford F-150	38	20				
		06-08	Lincoln Mark LT						
34	65046	03-09	Dodge Ram 2500	42	40				
		03-09	Dodge Ram 3500						
23	65048	97-06	Jeep TJ (Canada Only)	24	25				
		87-06	Jeep Wrangler						
		87-95	Jeep YJ (Canada Only)						
30	65049	08-16	Ford F-250 Super Duty	35	20				
		08-16	Ford F-350 Super Duty						
		08-16	Ford F-350 Super Duty Cab & Chassis						
		08-16	Ford F-450 Super Duty						
		08-16	Ford F-450 Super Duty Cab & Chassis						
		08-16	Ford F-550 Super Duty Cab & Chassis						
22	65050	07-10	Chevrolet Silverado 2500 HD	29	40				
		07-10	Chevrolet Silverado 3500 HD						
		07-10	GMC Sierra 2500 HD						
		07-10	GMC Sierra 3500 HD						
		07-10	GMC Sierra 3500 HD						
16	65051f	07-17	Toyota Tundra	39	25				
30	65052	07-13	Chevrolet Avalanche Except Z71	40	25				
		07-13	Chevrolet Silverado 1500						
		07-14	Chevrolet Suburban 1500 Except Z71						
		07-14	Chevrolet Tahoe Except Z71						
		07-13	GMC Sierra 1500						

PC	PART NO.	YEARS	MAKE/MODEL	WGT LBS	IN
30	65052	07-14	GMC Yukon	40	25
		07-14	GMC Yukon XL 1500		
19	65053	08-14	Ford E-150 Econoline	32	40
		08-14	Ford E-250 Econoline		
		08-14	Ford E-350 Econoline Super Duty		
		08-17	Ford E-350 Econoline Super Duty RV Cutaway		
		08-17	Ford E-450 Econoline Super Duty RV Cutaway		
35	65057	10	Dodge Ram 2500 4 WD	32	40
		11-12	RAM 2500 4 WD		
38	65060	10	Dodge Ram 3500	38	30
		11-12	RAM 3500		
34	65061	09-14	Ford F-150	42	30
		10-13	Lincoln Mark LT (Mexico Only)		
32	65062	09-10	Dodge Ram 1500	43	35
		11-18	RAM 1500		
		19	RAM 1500 (Classic)		
33	65063	10	Dodge Ram 2500	24	30
		10	Dodge Ram 3500		
		10	Dodge Ram 4500 Cab & Chassis		
		10	Dodge Ram 5500 Cab & Chassis		
		11-18	RAM 2500		
		11-18	RAM 3500		
30	65064	14-19	Chevrolet Silverado 1500 LD (Old Body Style)	35	25
		15-19	Chevrolet Suburban		
		15-19	Chevrolet Tahoe		
		14-19	GMC Sierra 1500 LD (Old Body Style)		
30	65064	15-19	GMC Yukon	35	25
		15-19	GMC Yukon XL		
		15-19	GMC Yukon XL		
		15-19	GMC Yukon XL		
44	65065	09-15	Nissan Titan 4 WD Only	45	45
31	65067	15-19	Ford F-150	37	30
19	65069	07-17	Jeep Wrangler	22	40
		18	Jeep Wrangler JK		
52	65070	05-19	Toyota Tacoma	47	35
23	65071	15-16	Chevrolet Colorado	32	30
		15-16	GMC Canyon		
30	65072	16	Nissan Titan XD	29	25
27	65073	17	Honda Ridgeline	26	35
34	65074	14-19	Toyota 4Runner Except Limited	28	20
24	65075	05-19	Nissan Frontier	34	35
		05-12	Nissan Pathfinder		
		09-12	Suzuki Equator Sport & RMZ-4 Models		
29	65076	17-19	Ford F-250 Super Duty	36	30
		17-19	Ford F-350 Super Duty		
		17-19	Ford F-450 Super Duty		
30	65077	17	Nissan Titan Except Titan XD & 4 WD Models	42	60
24	65078	11-19	Chevrolet Silverado 2500 HD	29	35
		11-19	Chevrolet Silverado 2500 HD		
		11-17	Chevrolet Silverado 3500 HD		
		11-17	Chevrolet Silverado 3500 HD		
		11-19	GMC Sierra 2500 HD Except Denali		
		11-19	GMC Sierra 2500 HD Except Denali		
19	65079	20	Jeep Gladiator	30	35
		18-19	Jeep Wrangler JL (New Body Style)		
		18-19	Jeep Wrangler JL (New Body Style)		
16	65080	07-19	Toyota Sequoia	39	20
		07-19	Toyota Tundra		
32	65081	19	RAM 1500 (New Body Style), Except with Factory Tow Hooks	52	50
		19	RAM 1500 (New Body Style), Except with Factory Tow Hooks		
30	65082	19	Chevrolet Silverado 1500	31	25
1 - PLUG ADAPTERS					
	20277f	13-14	RAM 1500		5
		13-14	RAM 2500		
		13-14	RAM 3500		
	3014-S	14-19	Jeep Cherokee		5
	3015-S	03-06	Cadillac Escalade		5
		03-06	Cadillac Escalade ESV		
		03-06	Cadillac Escalade EXT		
		03-06	Chevrolet Avalanche 1500		
		03-06	Chevrolet Avalanche 2500		
		03-06	Chevrolet Silverado 1500		
		07	Chevrolet Silverado 1500 (Classic)		
		03-06	Chevrolet Silverado 1500 HD		
07	Chevrolet Silverado 1500 HD (Classic)				
03-04	Chevrolet Silverado 2500		5		

BRAKE CONTROL HARNESS INDEX

PC	PART NO.	YEARS	MAKE/MODEL	WGT	
				LBS	IN
3015-S	03-06	07	Chevrolet Silverado 2500 HD		5
		07	Chevrolet Silverado 2500 HD (Classic)		5
	03-06	07	Chevrolet Silverado 3500		5
		07	Chevrolet Silverado 3500 (Classic)		5
	03-06		Chevrolet Suburban 1500		5
	03-06		Chevrolet Suburban 2500		5
	03-06		Chevrolet Tahoe		5
	03-06	07	GMC Sierra 1500		5
		07	GMC Sierra 1500 (Classic)		5
	03-06	07	GMC Sierra 1500 HD		5
		07	GMC Sierra 1500 HD (Classic)		5
	03-04		GMC Sierra 2500		5
	03-06		GMC Sierra 2500 HD		5
		07	GMC Sierra 2500 HD (Classic)		5
	03-06		GMC Sierra 3500		5
		07	GMC Sierra 3500 (Classic)		5
	03-06		GMC Yukon		5
	03-06		GMC Yukon Denali		5
	03-06		GMC Yukon XL 1500		5
	03-06		GMC Yukon XL 1500 Denali		5
03-06		GMC Yukon XL 2500		5	
03-07		Hummer H2		5	
3016-S	15-18		Cadillac Escalade		5
	14-18		Chevrolet Silverado 1500		5
	15-19		Chevrolet Silverado 2500 HD		5
	15-19		Chevrolet Silverado 3500 HD		5
	15-17		Chevrolet Suburban		5
	15-16		Chevrolet Tahoe		5
	14-19		GMC Sierra 1500 LD (Old Body Style)		5
	15-19		GMC Sierra 2500 HD		5
	15-19		GMC Sierra 3500 HD		5
	15-16		GMC Yukon		5
	3020-S	07-09		Chrysler Aspen w/Factory Tow Package	
97-10			Dodge Dakota w/Factory Tow Package		5
98-09			Dodge Durango w/Factory Tow Package		5
95-09			Dodge Ram 1500		5
95-09			Dodge Ram 2500		5
95-09		11	Dodge Ram 3500		5
			RAM Dakota w/Factory Tow Package		5
3021-S	10		Dodge Ram 1500		5
	10		Dodge Ram 2500		5
	10		Dodge Ram 3500		5
	11-12		RAM 1500		5
	11-12		RAM 2500		5
11-12		RAM 3500		5	
3023-S	13-14		RAM 1500		5
	13-14		RAM 2500		5
	13-14		RAM 3500		5
3025-S	02		Cadillac Escalade		5
	02		Cadillac Escalade EXT		5
	02		Chevrolet Avalanche 1500		5
	02		Chevrolet Avalanche 2500		5
	99-02		Chevrolet Silverado 1500		5
	01-02		Chevrolet Silverado 1500 HD		5
	99-02		Chevrolet Silverado 2500		5
	01-02		Chevrolet Silverado 2500 HD		5
	01-02		Chevrolet Silverado 3500		5
	00-02		Chevrolet Suburban 1500 w/Amber Turn Signals		5
	00-02		Chevrolet Suburban 2500 w/Amber Turn Signals		5
	00-02		Chevrolet Tahoe w/Amber Turn Signals		5
	99-02		GMC Sierra 1500		5
	01-02		GMC Sierra 1500 HD		5
	99-02		GMC Sierra 2500		5
	01-02		GMC Sierra 2500 HD		5
	01-02		GMC Sierra 3500		5
	01-02		GMC Yukon Denali w/Amber Turn Signals		5
	00-02		GMC Yukon w/Amber Turn Signals		5
	00-02		GMC Yukon XL 1500		5
01-02		GMC Yukon XL 1500 Denali		5	
00-02		GMC Yukon XL 2500		5	
3026-S	08-17		Buick Enclave w/Factory 7-Way		5
	09-17		Chevrolet Traverse w/Factory 7-Way		5
	17		GMC Acadia Limited w/Factory 7-Way		5
	07-17		GMC Acadia w/Factory 7-Way		5
	07-09		Saturn Outlook w/Factory 7-Way		5
3031-S	16-19		Toyota Tacoma		5
	15-17		Toyota Tundra		5

PC	PART NO.	YEARS	MAKE/MODEL	WGT		
				LBS	IN	
3034-S	09-14		Ford E-150 Econoline		20	
	09-14		Ford E-250 Econoline		20	
	09-14		Ford E-350 Econoline Super Duty		20	
	09-11		Ford E-350 Econoline Super Duty RV Cutaway, w/Factory Tow Prep Plug		20	
	09-11		Ford E-450 Econoline Super Duty RV Cutaway, w/Factory Tow Prep Plug		20	
	13-14		Ford Expedition		20	
	08-16		Ford F-250 Super Duty		20	
	08-16		Ford F-350 Super Duty		20	
	08-16		Ford F-350 Super Duty Cab & Chassis		20	
	08-16		Ford F-450 Super Duty		20	
	08-16		Ford F-450 Super Duty Cab & Chassis		20	
	08-16		Ford F-550 Super Duty Cab & Chassis		20	
	13-14		Lincoln Navigator		20	
	3035-S	94-96		Ford Bronco		5
		92-08		Ford E-150 Econoline		5
		92-08		Ford E-250 Econoline		5
		92-08		Ford E-350 Econoline		5
		92-08		Ford E-350 Econoline RV Cutaway, w/Factory Tow Prep Plug		5
		03-08		Ford E-450 Econoline Super Duty RV Cutaway, w/Factory Tow Prep Plug		5
		00-02		Ford E-450 Econoline Super Duty Stripped RV Cutaway, w/Factory Tow Prep Plug		5
00-05			Ford Excursion		5	
97-12			Ford Expedition		5	
07-10			Ford Explorer Sport Trac w/Factory Tow Package		5	
02-19			Ford Explorer w/Factory Tow Package		5	
94-08			Ford F-150		5	
04			Ford F-150 Heritage		5	
94-96			Ford F-250		5	
97			Ford F-250 Heavy Duty		5	
97-99			Ford F-250 Styleside		5	
99-04			Ford F-250 Super Duty		5	
94-96			Ford F-350		5	
97			Ford F-350 Heavy Duty		5	
99-04			Ford F-350 Super Duty		5	
99-04		Ford F-450 Super Duty Cab & Chassis		5		
99-04		Ford F-550 Super Duty Cab & Chassis		5		
09-11		Ford Flex w/Factory Tow Package		5		
95-03		Ford Windstar w/Factory Tow Package		5		
05-09		Land Rover LR3		5		
10-15		Land Rover LR4		5		
05-15		Land Rover Range Rover		5		
12-17		Land Rover Range Rover Evoque		5		
03-05		Lincoln Aviator w/Factory Tow Package		5		
06-08		Lincoln Mark LT		5		
10-11		Lincoln MKT w/Factory Tow Package		5		
98-12		Lincoln Navigator		5		
02-10		Mercury Mountaineer w/Factory Tow Package		5		
3036-S	15-17		Ford Expedition		20	
	09-19		Ford F-150		20	
	17-19		Ford F-250 Super Duty		20	
	17-19		Ford F-350 Super Duty		20	
	17-19		Ford F-450 Super Duty		20	
	17-18		Ford F-550 Super Duty		20	
	12-16		Ford Flex w/Factory Tow Package		20	
	12-15		Lincoln MKT w/Factory Tow Package		20	
	15-17		Lincoln Navigator		20	
	3040-S	10-15		Lexus GX460		5
03-09			Lexus GX470		5	
03-07			Lexus LX470		5	
08-15			Lexus LX570		5	
03-13			Toyota 4Runner		5	
03-15			Toyota Land Cruiser		5	
03-19			Toyota Sequoia		5	
07-15			Toyota Tacoma		5	
03-14			Toyota Tundra		5	
3045-S		17-19		Chrysler Pacifica w/Factory 7-Way		5
	11-19		Dodge Durango w/Factory Tow Package		5	
	11-19		Jeep Grand Cherokee w/Factory Tow Package		5	
3050-S	04-13		Infiniti QX56		5	
	05-15		Nissan Armada		5	
	05-15		Nissan Frontier		5	
	13-15		Nissan NV1500		5	
	13-15		Nissan NV2500		5	

BRAKE CONTROL HARNESS INDEX

PC	PART NO.	YEARS	MAKE/MODEL	WGT LBS	IN		
	3050-S	13-15	Nissan NV3500		5		
		05-17	Nissan Pathfinder		5		
		04	Nissan Pathfinder Armada		5		
		04-17	Nissan Titan Except Titan XD		5		
		05-15	Nissan Xterra w/Factory Tow Package		5		
	3065-S	05-07	Ford F-250 Super Duty		5		
		05-07	Ford F-350 Super Duty		5		
		05-07	Ford F-350 Super Duty Cab & Chassis		5		
		05-07	Ford F-450 Super Duty Cab & Chassis		5		
		05-07	Ford F-550 Super Duty Cab & Chassis		5		
	3070-S	09-17	Honda Pilot w/Factory Tow Package		5		
		06-17	Honda Ridgeline w/Factory Tow Package		5		
2 - PLUG ADAPTERS							
	3014	14-19	Jeep Cherokee		5		
	3014-P	14-19	Jeep Cherokee		5		
	3015	03-06	Cadillac Escalade		5		
		03-06	Cadillac Escalade ESV		5		
		03-06	Cadillac Escalade EXT		5		
		03-06	Chevrolet Avalanche 1500		5		
		03-06	Chevrolet Avalanche 2500		5		
		03-06	Chevrolet Silverado 1500		5		
		07	Chevrolet Silverado 1500 (Classic)		5		
		03-06	Chevrolet Silverado 1500 HD		5		
		07	Chevrolet Silverado 1500 HD (Classic)		5		
		03-04	Chevrolet Silverado 2500		5		
		03-06	Chevrolet Silverado 2500 HD		5		
		07	Chevrolet Silverado 2500 HD (Classic)		5		
		03-06	Chevrolet Silverado 3500		5		
		07	Chevrolet Silverado 3500 (Classic)		5		
		03-06	Chevrolet Suburban 1500		5		
		03-06	Chevrolet Suburban 2500		5		
		03-06	Chevrolet Tahoe		5		
		03-06	GMC Sierra 1500		5		
		07	GMC Sierra 1500 (Classic)		5		
		03-06	GMC Sierra 1500 HD		5		
		07	GMC Sierra 1500 HD (Classic)		5		
		03-04	GMC Sierra 2500		5		
		03-06	GMC Sierra 2500 HD		5		
		07	GMC Sierra 2500 HD (Classic)		5		
		03-06	GMC Sierra 3500		5		
		07	GMC Sierra 3500 (Classic)		5		
		03-06	GMC Yukon		5		
		03-06	GMC Yukon Denali		5		
		03-06	GMC Yukon XL 1500		5		
		03-06	GMC Yukon XL 1500 Denali		5		
		03-06	GMC Yukon XL 2500		5		
		03-07	Hummer H2		5		
			3015-P	03-06	Cadillac Escalade		5
				03-06	Cadillac Escalade ESV		5
				03-06	Cadillac Escalade EXT		5
				03-06	Chevrolet Avalanche 1500		5
				03-06	Chevrolet Avalanche 2500		5
				03-06	Chevrolet Silverado 1500		5
				07	Chevrolet Silverado 1500 (Classic)		5
				03-06	Chevrolet Silverado 1500 HD		5
07	Chevrolet Silverado 1500 HD (Classic)				5		
03-04	Chevrolet Silverado 2500				5		
03-06	Chevrolet Silverado 2500 HD				5		
07	Chevrolet Silverado 2500 HD (Classic)				5		
03-06	Chevrolet Silverado 3500				5		
07	Chevrolet Silverado 3500 (Classic)				5		
03-06	Chevrolet Suburban 1500				5		
03-06	Chevrolet Suburban 2500				5		
03-06	Chevrolet Tahoe				5		
03-06	GMC Sierra 1500				5		
07	GMC Sierra 1500 (Classic)				5		
03-06	GMC Sierra 1500 HD				5		
07	GMC Sierra 1500 HD (Classic)				5		
03-04	GMC Sierra 2500				5		
03-06	GMC Sierra 2500 HD				5		
07	GMC Sierra 2500 HD (Classic)				5		
03-06	GMC Sierra 3500				5		
07	GMC Sierra 3500 (Classic)				5		
03-06	GMC Yukon				5		
03-06	GMC Yukon Denali				5		
03-06	GMC Yukon XL 1500				5		
03-06	GMC Yukon XL 1500 Denali				5		

PC	PART NO.	YEARS	MAKE/MODEL	WGT LBS	IN	
	3015-P	03-06	GMC Yukon XL 2500		5	
		03-07	Hummer H2		5	
	3016	15-18	Cadillac Escalade		5	
		14-18	Chevrolet Silverado 1500		5	
		15-19	Chevrolet Silverado 2500 HD		5	
		15-19	Chevrolet Silverado 3500 HD		5	
		15-17	Chevrolet Suburban		5	
		15-16	Chevrolet Tahoe		5	
		14-19	GMC Sierra 1500 LD (Old Body Style)		5	
		15-19	GMC Sierra 2500 HD		5	
		15-19	GMC Sierra 3500 HD		5	
		15-16	GMC Yukon		5	
	3016-P	15-18	Cadillac Escalade		5	
		14-18	Chevrolet Silverado 1500		5	
		15-19	Chevrolet Silverado 2500 HD		5	
		15-19	Chevrolet Silverado 3500 HD		5	
		15-17	Chevrolet Suburban		5	
	3017†	16-17	Toyota Tacoma		5	
		15-17	Toyota Tundra		5	
		3017-P†	16-17	Toyota Tacoma		5
			15-17	Toyota Tundra		5
			3020	07-09	Chrysler Aspen w/Factory Tow Package	
97-10	Dodge Dakota w/Factory Tow Package			5		
98-09	Dodge Durango w/Factory Tow Package			5		
95-09	Dodge Ram 1500			5		
95-09	Dodge Ram 2500			5		
95-09	Dodge Ram 3500		5			
11	RAM Dakota w/Factory Tow Package		5			
3020-P	07-09	Chrysler Aspen w/Factory Tow Package		5		
	97-10	Dodge Dakota w/Factory Tow Package		5		
	98-09	Dodge Durango w/Factory Tow Package		5		
	95-09	Dodge Ram 1500		5		
	95-09	Dodge Ram 2500		5		
95-09	Dodge Ram 3500		5			
11	RAM Dakota w/Factory Tow Package		5			
3021	10	Dodge Ram 1500		5		
	10	Dodge Ram 2500		5		
	10	Dodge Ram 3500		5		
	11-12	RAM 1500		5		
	11-12	RAM 2500		5		
11-12	RAM 3500		5			
3021-P	10	Dodge Ram 1500		5		
	10	Dodge Ram 2500		5		
	10	Dodge Ram 3500		5		
	11-12	RAM 1500		5		
	11-12	RAM 2500		5		
11-12	RAM 3500		5			
3023	13-14	RAM 1500		10		
	13-14	RAM 2500		10		
	13-14	RAM 3500		10		
30234-P	13-14	RAM 1500	2	45		
	13-14	RAM 2500		45		
	13-14	RAM 3500		45		
30235	13-19	RAM 1500 (Classic)	1	30		
	19	RAM 1500 (New Body Style)		30		
	13-19	RAM 2500		30		
	13-19	RAM 3500		30		
30235-P	13-19	RAM 1500 (Classic)	2	30		
	19	RAM 1500 (New Body Style)		30		
	13-19	RAM 2500		30		
13-19	RAM 3500		30			
3023-P	13-14	RAM 1500		10		
	13-14	RAM 2500		10		
	13-14	RAM 3500		10		
3024	15-19	RAM 1500 (Classic)		5		
	15-19	RAM 2500		5		
	15-19	RAM 3500		5		
3024-P	15-19	RAM 1500 (Classic)		5		
	15-19	RAM 2500		5		
	15-19	RAM 3500		5		
3025	02	Cadillac Escalade		5		
	02	Cadillac Escalade EXT		5		

BRAKE CONTROL HARNESS INDEX

PC	PART NO.	YEARS	MAKE/MODEL	WGT	
				LBS	IN
	3025	02	Chevrolet Avalanche 1500		5
		02	Chevrolet Avalanche 2500		5
		99-02	Chevrolet Silverado 1500		5
		01-02	Chevrolet Silverado 1500 HD		5
		99-02	Chevrolet Silverado 2500		5
		01-02	Chevrolet Silverado 2500 HD		5
		01-02	Chevrolet Silverado 3500		5
		00-02	Chevrolet Suburban 1500 w/Amber Turn Signals		5
		00-02	Chevrolet Suburban 2500 w/Amber Turn Signals		5
		00-02	Chevrolet Tahoe w/Amber Turn Signals		5
		99-02	GMC Sierra 1500		5
		01-02	GMC Sierra 1500 HD		5
		99-02	GMC Sierra 2500		5
		01-02	GMC Sierra 2500 HD		5
		01-02	GMC Sierra 3500		5
		01-02	GMC Yukon Denali w/Amber Turn Signals		5
		00-02	GMC Yukon w/Amber Turn Signals		5
		00-02	GMC Yukon XL 1500		5
		01-02	GMC Yukon XL 1500 Denali		5
		00-02	GMC Yukon XL 2500		5
3025-P		02	Cadillac Escalade		5
		02	Cadillac Escalade EXT		5
		02	Chevrolet Avalanche 1500		5
		02	Chevrolet Avalanche 2500		5
		99-02	Chevrolet Silverado 1500		5
		01-02	Chevrolet Silverado 1500 HD		5
		99-02	Chevrolet Silverado 2500		5
		01-02	Chevrolet Silverado 2500 HD		5
		01-02	Chevrolet Silverado 3500		5
		00-02	Chevrolet Suburban 1500 w/Amber Turn Signals		5
		00-02	Chevrolet Suburban 2500 w/Amber Turn Signals		5
		00-02	Chevrolet Tahoe w/Amber Turn Signals		5
		99-02	GMC Sierra 1500		5
		01-02	GMC Sierra 1500 HD		5
		99-02	GMC Sierra 2500		5
		01-02	GMC Sierra 2500 HD		5
		01-02	GMC Sierra 3500		5
		01-02	GMC Yukon Denali w/Amber Turn Signals		5
		00-02	GMC Yukon w/Amber Turn Signals		5
		00-02	GMC Yukon XL 1500		5
01-02	GMC Yukon XL 1500 Denali		5		
00-02	GMC Yukon XL 2500		5		
3026		08-17	Buick Enclave w/Factory 7-Way		5
		09-17	Chevrolet Traverse w/Factory 7-Way		5
		17	GMC Acadia Limited w/Factory 7-Way		5
		07-17	GMC Acadia w/Factory 7-Way		5
		07-09	Saturn Outlook w/Factory 7-Way		5
3026-P		08-17	Buick Enclave w/Factory 7-Way		5
		09-17	Chevrolet Traverse w/Factory 7-Way		5
		17	GMC Acadia Limited w/Factory 7-Way		5
		07-17	GMC Acadia w/Factory 7-Way		5
		07-09	Saturn Outlook w/Factory 7-Way		5
3027		04-16	Freightliner SL		5
		04-16	Freightliner XC		5
3027-P		04-16	Freightliner SL		5
		04-16	Freightliner XC		5
3028		13-19	Acura MDX		10
3028-P		13-19	Acura MDX		10
3030		12-18	Freightliner Sprinter 2500		10
		12-18	Freightliner Sprinter 3500		10
		12-18	Mercedes-Benz Sprinter		10
		19	Mercedes-Benz Sprinter 1500		10
3030-P		12-18	Freightliner Sprinter 2500		10
		12-18	Freightliner Sprinter 3500		10
		12-18	Mercedes-Benz Sprinter		10
		19	Mercedes-Benz Sprinter 1500		10
3031		16-19	Toyota Tacoma		5
		15-17	Toyota Tundra		5
3031-P		16-19	Toyota Tacoma		5
		15-17	Toyota Tundra		5
3032		09-11	KIA Borrego		5
3032-P		09-11	KIA Borrego		5
3034		09-14	Ford E-150 Econoline		20
		09-14	Ford E-250 Econoline		20
		09-14	Ford E-350 Econoline Super Duty		20
		09-11	Ford E-350 Econoline Super Duty RV Cutaway, w/Factory Tow Prep Plug		20

PC	PART NO.	YEARS	MAKE/MODEL	WGT			
				LBS	IN		
	3034	09-11	Ford E-450 Econoline Super Duty RV Cutaway, w/Factory Tow Prep Plug		20		
		13-14	Ford Expedition				
		08-16	Ford F-250 Super Duty		20		
		08-16	Ford F-350 Super Duty		20		
		08-16	Ford F-350 Super Duty Cab & Chassis		20		
		08-16	Ford F-450 Super Duty		20		
		08-16	Ford F-450 Super Duty Cab & Chassis		20		
		08-16	Ford F-550 Super Duty Cab & Chassis		20		
		13-14	Lincoln Navigator		20		
		3034-P		09-14	Ford E-150 Econoline		20
				09-14	Ford E-250 Econoline		20
				09-14	Ford E-350 Econoline Super Duty		20
				09-11	Ford E-350 Econoline Super Duty RV Cutaway, w/Factory Tow Prep Plug		20
09-11	Ford E-450 Econoline Super Duty RV Cutaway, w/Factory Tow Prep Plug				20		
13-14	Ford Expedition						
08-16	Ford F-250 Super Duty				20		
08-16	Ford F-350 Super Duty				20		
08-16	Ford F-350 Super Duty Cab & Chassis				20		
08-16	Ford F-450 Super Duty Cab & Chassis				20		
08-16	Ford F-550 Super Duty Cab & Chassis				20		
13-14	Lincoln Navigator				20		
3035				94-96	Ford Bronco		5
		92-08	Ford E-150 Econoline		5		
		92-08	Ford E-250 Econoline		5		
		92-08	Ford E-350 Econoline		5		
		92-08	Ford E-350 Econoline RV Cutaway, w/Factory Tow Prep Plug		5		
		03-08	Ford E-450 Econoline Super Duty RV Cutaway, w/Factory Tow Prep Plug		5		
		00-02	Ford E-450 Econoline Super Duty Stripped RV Cutaway, w/Factory Tow Prep Plug		5		
		00-05	Ford Excursion		5		
		97-12	Ford Expedition		5		
		07-10	Ford Explorer Sport Trac w/Factory Tow Package		5		
		02-19	Ford Explorer w/Factory Tow Package		5		
		94-08	Ford F-150		5		
		04	Ford F-150 Heritage		5		
94-96	Ford F-250		5				
97	Ford F-250 Heavy Duty		5				
97-99	Ford F-250 Styleside		5				
99-04	Ford F-250 Super Duty		5				
94-96	Ford F-350		5				
97	Ford F-350 Heavy Duty		5				
99-04	Ford F-350 Super Duty		5				
99-04	Ford F-450 Super Duty Cab & Chassis		5				
99-04	Ford F-550 Super Duty Cab & Chassis		5				
09-11	Ford Flex w/Factory Tow Package		5				
95-03	Ford Windstar w/Factory Tow Package		5				
05-09	Land Rover LR3		5				
10-15	Land Rover LR4		5				
05-15	Land Rover Range Rover		5				
12-17	Land Rover Range Rover Evoque		5				
03-05	Lincoln Aviator w/Factory Tow Package		5				
06-08	Lincoln Mark LT		5				
10-11	Lincoln MKT w/Factory Tow Package		5				
98-12	Lincoln Navigator		5				
02-10	Mercury Mountaineer w/Factory Tow Package		5				
3035-P		94-96	Ford Bronco		5		
		92-08	Ford E-150 Econoline		5		
		92-08	Ford E-250 Econoline		5		
		92-08	Ford E-350 Econoline		5		
		92-08	Ford E-350 Econoline RV Cutaway, w/Factory Tow Prep Plug		5		
		03-08	Ford E-450 Econoline Super Duty RV Cutaway, w/Factory Tow Prep Plug		5		
		00-02	Ford E-450 Econoline Super Duty Stripped RV Cutaway, w/Factory Tow Prep Plug		5		
		00-05	Ford Excursion		5		
		97-12	Ford Expedition		5		
		07-10	Ford Explorer Sport Trac w/Factory Tow Package		5		
		02-19	Ford Explorer w/Factory Tow Package		5		
		94-08	Ford F-150		5		
		04	Ford F-150 Heritage		5		

PC	PART NO.	YEARS	MAKE/MODEL	WGT LBS	IN		
3035-P		94-96	Ford F-250	5	5		
		97	Ford F-250 Heavy Duty	5	5		
		97-99	Ford F-250 Styleside	5	5		
		99-04	Ford F-250 Super Duty	5	5		
		94-96	Ford F-350	5	5		
		97	Ford F-350 Heavy Duty	5	5		
		99-04	Ford F-350 Super Duty	5	5		
		99-04	Ford F-450 Super Duty Cab & Chassis	5	5		
		99-04	Ford F-550 Super Duty Cab & Chassis	5	5		
		09-11	Ford Flex w/Factory Tow Package	5	5		
		95-03	Ford Windstar w/Factory Tow Package	5	5		
		05-09	Land Rover LR3	5	5		
		10-15	Land Rover LR4	5	5		
		05-15	Land Rover Range Rover	5	5		
		12-17	Land Rover Range Rover Evoque	5	5		
		03-05	Lincoln Aviator w/Factory Tow Package	5	5		
		06-08	Lincoln Mark LT	5	5		
		10-11	Lincoln MKT w/Factory Tow Package	5	5		
		98-12	Lincoln Navigator	5	5		
		02-10	Mercury Mountaineer w/Factory Tow Package	5	5		
		3036		15-17	Ford Expedition	20	20
				09-19	Ford F-150	20	20
				17-19	Ford F-250 Super Duty	20	20
				17-19	Ford F-350 Super Duty	20	20
				17-19	Ford F-450 Super Duty	20	20
				17-18	Ford F-550 Super Duty	20	20
				12-16	Ford Flex w/Factory Tow Package	20	20
12-15	Lincoln MKT w/Factory Tow Package			20	20		
15-17	Lincoln Navigator			20	20		
3036-P				15-17	Ford Expedition	20	20
		09-19	Ford F-150	20	20		
		17-19	Ford F-250 Super Duty	20	20		
		17-19	Ford F-350 Super Duty	20	20		
		17-19	Ford F-450 Super Duty	20	20		
		17-18	Ford F-550 Super Duty	20	20		
		12-16	Ford Flex w/Factory Tow Package	20	20		
		12-15	Lincoln MKT w/Factory Tow Package	20	20		
		15-17	Lincoln Navigator	20	20		
		3040		10-15	Lexus GX460	5	5
03-09	Lexus GX470			5	5		
03-07	Lexus LX470			5	5		
08-15	Lexus LX570			5	5		
03-13	Toyota 4Runner			5	5		
03-15	Toyota Land Cruiser			5	5		
03-19	Toyota Sequoia			5	5		
07-15	Toyota Tacoma			5	5		
03-14	Toyota Tundra			5	5		
3040-P				10-15	Lexus GX460	5	5
		03-09	Lexus GX470	5	5		
		03-07	Lexus LX470	5	5		
		08-15	Lexus LX570	5	5		
		03-13	Toyota 4Runner	5	5		
		03-15	Toyota Land Cruiser	5	5		
		03-19	Toyota Sequoia	5	5		
		07-15	Toyota Tacoma	5	5		
		03-14	Toyota Tundra	5	5		
		3041	14-16	Toyota 4Runner	10	10	
3041-P	14-16	Toyota 4Runner	10	10			
3045		17-19	Chrysler Pacifica w/Factory 7-Way	5	5		
		11-19	Dodge Durango w/Factory Tow Package	5	5		
		11-19	Jeep Grand Cherokee w/Factory Tow Package	5	5		
3045-P		17-19	Chrysler Pacifica w/Factory 7-Way	5	5		
		11-19	Dodge Durango w/Factory Tow Package	5	5		
		11-19	Jeep Grand Cherokee w/Factory Tow Package	5	5		
3050		04-13	Infiniti QX56	5	5		
		14-17	Infiniti QX60 Except Hybrid	5	5		
		14	Infiniti QX60 Hybrid	5	5		
		14-17	Infiniti QX80	5	5		
		05-15	Nissan Armada	5	5		
		05-15	Nissan Frontier	5	5		
		13-15	Nissan NV1500	5	5		
		13-15	Nissan NV2500	5	5		
		13-15	Nissan NV3500	5	5		
		05-17	Nissan Pathfinder	5	5		
		04	Nissan Pathfinder Armada	5	5		
		04-17	Nissan Titan Except Titan XD	5	5		
		05-15	Nissan Xterra w/Factory Tow Package	5	5		

PC	PART NO.	YEARS	MAKE/MODEL	WGT LBS	IN		
3050-P		04-13	Infiniti QX56	5	5		
		05-15	Nissan Armada	5	5		
		05-15	Nissan Frontier	5	5		
		13-15	Nissan NV1500	5	5		
		13-15	Nissan NV2500	5	5		
		13-15	Nissan NV3500	5	5		
		05-17	Nissan Pathfinder	5	5		
		04	Nissan Pathfinder Armada	5	5		
		04-17	Nissan Titan Except Titan XD	5	5		
		05-15	Nissan Xterra w/Factory Tow Package	5	5		
		3062	19	Subaru Ascent	10	10	
		3062-P	19	Subaru Ascent	10	10	
		3063		07-09	Dodge Sprinter 2500	10	10
				07-09	Dodge Sprinter 3500	10	10
				07-11	Freightliner Sprinter 2500	10	10
				07-11	Freightliner Sprinter 3500	10	10
				07-11	Mercedes-Benz Sprinter	10	10
				10-19	Mercedes-Benz Sprinter 2500	10	10
				10-19	Mercedes-Benz Sprinter 3500	10	10
3063-P		07-09	Dodge Sprinter 2500	10	10		
		07-09	Dodge Sprinter 3500	10	10		
		07-11	Freightliner Sprinter 2500	10	10		
		07-11	Freightliner Sprinter 3500	10	10		
		07-11	Mercedes-Benz Sprinter	10	10		
		10-19	Mercedes-Benz Sprinter 2500	10	10		
		10-19	Mercedes-Benz Sprinter 3500	10	10		
3064		19	Chevrolet Silverado 1500 (New Body Style)	10	10		
		19	GMC Sierra 1500 (New Body Style)	10	10		
3064-P		19	Chevrolet Silverado 1500 (New Body Style)	10	10		
		19	GMC Sierra 1500 (New Body Style)	10	10		
3065		05-07	Ford F-250 Super Duty	5	5		
		05-07	Ford F-350 Super Duty	5	5		
		05-07	Ford F-350 Super Duty Cab & Chassis	5	5		
		05-07	Ford F-450 Super Duty Cab & Chassis	5	5		
		05-07	Ford F-550 Super Duty Cab & Chassis	5	5		
3065-P		05-07	Ford F-250 Super Duty	5	5		
		05-07	Ford F-350 Super Duty	5	5		
		05-07	Ford F-350 Super Duty Cab & Chassis	5	5		
		05-07	Ford F-450 Super Duty Cab & Chassis	5	5		
		05-07	Ford F-550 Super Duty Cab & Chassis	5	5		
3066		12-15	Mercedes-Benz GL350 w/ Factory Tow Package	10	10		
		12-15	Mercedes-Benz GL450 w/ Factory Tow Package	10	10		
		12-15	Mercedes-Benz GL550 w/ Factory Tow Package	10	10		
		16-18	Mercedes-Benz GLE350 w/ Factory Tow Package	10	10		
		17-18	Mercedes-Benz GLE43 AMG w/ Factory Tow Package	10	10		
		16-17	Mercedes-Benz GLE550 w/ Factory Tow Package	10	10		
		16-18	Mercedes-Benz GLE63 AMG w/ Factory Tow Package	10	10		
		17-18	Mercedes-Benz GLS450 w/ Factory Tow Package	10	10		
		17-18	Mercedes-Benz GLS550 w/ Factory Tow Package	10	10		
		17-18	Mercedes-Benz GLS63 AMG w/ Factory Tow Package	10	10		
3066-P		15	Mercedes-Benz ML250 w/ Factory Tow Package	10	10		
		12-15	Mercedes-Benz ML350 w/ Factory Tow Package	10	10		
		15	Mercedes-Benz ML400 w/ Factory Tow Package	10	10		
		12-15	Mercedes-Benz GL350 w/ Factory Tow Package	10	10		
		12-15	Mercedes-Benz GL450 w/ Factory Tow Package	10	10		
		12-15	Mercedes-Benz GL550 w/ Factory Tow Package	10	10		
		16-18	Mercedes-Benz GLE350 w/ Factory Tow Package	10	10		
		17-18	Mercedes-Benz GLE43 AMG w/ Factory Tow Package	10	10		
		16	Mercedes-Benz GLE550 w/ Factory Tow Package	10	10		
		16-18	Mercedes-Benz GLE63 AMG w/ Factory Tow Package	10	10		
3070		09-17	Honda Pilot w/Factory Tow Package	5	5		
		06-17	Honda Ridgeline w/Factory Tow Package	5	5		
		09-17	Honda Pilot w/Factory Tow Package	5	5		
		06-17	Honda Ridgeline w/Factory Tow Package	5	5		
		3073	20	Jeep Gladiator	10	10	
3073-P		18-19	Jeep Wrangler JL (New Body Style)	10	10		
		20	Jeep Gladiator	10	10		
3073-P		18-19	Jeep Wrangler JL (New Body Style)	10	10		
		18-19	Jeep Wrangler JL (New Body Style)	10	10		
T-ONE CONNECTOR							
E7	118300	04-07	Chrysler Town & Country	1	20		
		04-07	Dodge Caravan	1	20		

T-ONE® CONNECTOR INDEX

PC	PART NO.	YEARS	MAKE/MODEL	WGT			
				LBS	IN		
E7	118300	04-07	Dodge Grand Caravan	1	20		
E10	118301	04-12	Chevrolet Colorado	1	10		
		04-12	GMC Canyon		10		
		06	Isuzu i-280		10		
		07-08	Isuzu i-290		10		
		06	Isuzu i-350		10		
		07-08	Isuzu i-370		10		
		E11	118302	06-08	Acura TSX 4 Dr. Sedan	1	10
		03-07	Honda Accord 4 Dr. Sedan		10		
E17	118303	04-08	Chrysler Pacifica	1	25		
E10	118304	04-10	Toyota Sienna	1	20		
E19	118305	03	Ford Windstar (Built After 11/2002)	2	45		
E10	118306	03-06	Mitsubishi Outlander	1	25		
E8	118307	03-06	KIA Sorento		5		
E10	118308	02-06	Toyota Camry 4 Dr. Sedan	1	5		
E10	118309	02-05	KIA Sedona	1	25		
E1	118311	73-74	Chevrolet Blazer Full Size		5		
		75-84	Chevrolet Blazer K5 Full Size		5		
		73-84	Chevrolet C10		5		
		73-84	Chevrolet C20		5		
		73-84	Chevrolet C30		5		
		73-84	Chevrolet K10		5		
		73-84	Chevrolet K20		5		
		77-84	Chevrolet K30		5		
		73-84	Chevrolet Suburban C10		5		
		73-84	Chevrolet Suburban C20		5		
		73-84	Chevrolet Suburban K10		5		
		73-84	Chevrolet Suburban K20		5		
		75-78	GMC C15		5		
		73-74	GMC C15/C1500		5		
		79-84	GMC C1500		5		
		75-78	GMC C25		5		
		67-74	GMC C25/C2500		5		
		79-84	GMC C2500		5		
		75-78	GMC C35		5		
		73-74	GMC C35/C3500		5		
		79-84	GMC C3500		5		
		73-84	GMC Jimmy Full Size		5		
		67-78	GMC K15		5		
		79-84	GMC K1500		5		
		73-78	GMC K25		5		
		79-84	GMC K2500		5		
		67-78	GMC K35		5		
		79-84	GMC K3500		5		
		73-78	GMC Suburban C15		5		
		79-84	GMC Suburban C1500		5		
		75-78	GMC Suburban C25		5		
		79-84	GMC Suburban C2500		5		
		73-78	GMC Suburban K15		5		
		79-84	GMC Suburban K1500		5		
		73-78	GMC Suburban K25		5		
		79-84	GMC Suburban K2500		5		
		E3	118312	87-91	Chevrolet Blazer Full Size		5
				85-86	Chevrolet Blazer K5 Full Size		5
				85-86	Chevrolet C10		5
				85-86	Chevrolet C20		5
				88-91	Chevrolet C2500 Crew Cab		5
				85-86	Chevrolet C30		5
				88-91	Chevrolet C3500 Crew Cab		5
85-86	Chevrolet K10				5		
85-86	Chevrolet K20				5		
88-91	Chevrolet K2500 Crew Cab				5		
85-86	Chevrolet K30				5		
88-91	Chevrolet K3500 Crew Cab				5		
85-97	Chevrolet S10				5		
85-86	Chevrolet Suburban C10				5		
85-86	Chevrolet Suburban C20				5		
85-86	Chevrolet Suburban K10				5		
85-86	Chevrolet Suburban K20				5		
87-88	Chevrolet Suburban R10				5		
89-91	Chevrolet Suburban R1500				5		
87-88	Chevrolet Suburban R20				5		
89-91	Chevrolet Suburban R2500				5		
87-88	Chevrolet Suburban V10				5		
89-91	Chevrolet Suburban V1500				5		
87-88	Chevrolet Suburban V20				5		
89-91	Chevrolet Suburban V2500				5		

PC	PART NO.	YEARS	MAKE/MODEL	WGT	
				LBS	IN
E3	118312	85-86	GMC C1500		5
		85-86	GMC C2500		5
		88-91	GMC C2500 Crew Cab		5
		85-86	GMC C3500		5
		88-91	GMC C3500 Crew Cab		5
		85-91	GMC Jimmy Full Size		5
		85-86	GMC K1500		5
		85-86	GMC K2500		5
		88-91	GMC K2500 Crew Cab		5
		85-86	GMC K3500		5
		88-91	GMC K3500 Crew Cab		5
		85-90	GMC S15		5
		91-97	GMC Sonoma		5
		85-86	GMC Suburban C1500		5
		85-86	GMC Suburban C2500		5
		85-86	GMC Suburban K1500		5
		85-86	GMC Suburban K2500		5
		87-91	GMC Suburban R1500		5
		87-91	GMC Suburban R2500		5
		87-91	GMC Suburban V1500		5
87-91	GMC Suburban V2500		5		
		91	GMC Syclone		5
		96-97	Isuzu Hombre		5
E1	118313	80-86	Ford Bronco		5
		80-83	Ford F-100		5
		80-86	Ford F-150		5
		80-86	Ford F-250		5
		80-86	Ford F-350		5
		83-85	Ford Ranger		5
E4	118314	86-92	Ford Ranger		5
E3	118315	88-99	Chevrolet C1500 Except 88-91 Crew Cab		5
		88-99	Chevrolet C2500 Except 88-91 Crew Cab		5
		88-00	Chevrolet C3500 Except 88-91 Crew Cab		5
		88-99	Chevrolet K1500 Except 88-91 Crew Cab		5
		88-99	Chevrolet K2500 Except 88-91 Crew Cab		5
		88-00	Chevrolet K3500 Except 88-91 Crew Cab		5
		88-99	GMC C1500 Except 88-91 Crew Cab		5
		88-00	GMC C2500 Except 88-91 Crew Cab		5
		88-00	GMC C3500 Except 88-91 Crew Cab		5
		88-99	GMC K1500 Except 88-91 Crew Cab		5
		88-00	GMC K2500 Except 88-91 Crew Cab		5
		88-00	GMC K3500 Except 88-91 Crew Cab		5
		E5	118316	87-96	Ford F-150
87-96	Ford F-250				5
97	Ford F-250 Heavy Duty				5
87-96	Ford F-350				5
97	Ford F-350 Heavy Duty				5
E7	118317	86-93	Dodge D150		5
		86-93	Dodge D250		5
		86-93	Dodge D350		5
		87-93	Dodge D350 Cab & Chassis		5
		87-94	Dodge Dakota		5
		94	Dodge Ram 1500		5
		94	Dodge Ram 2500		5
		94	Dodge Ram 3500		5
		94-02	Dodge Ram 3500, Cab & Chassis		5
		86-93	Dodge Ramcharger		5
		86-93	Dodge W150		5
		86-93	Dodge W250		5
		86-93	Dodge W350		5
87-93	Dodge W350 Cab & Chassis		5		
E3	118319	99-00	Cadillac Escalade		5
		92-94	Chevrolet Blazer Full Size		5
		92-99	Chevrolet Suburban C1500		5
		92-99	Chevrolet Suburban C2500		5
		92-99	Chevrolet Suburban K1500		5
		92-99	Chevrolet Suburban K2500		5
		95-00	Chevrolet Tahoe		5
		92-99	GMC Suburban C1500		5
		92-99	GMC Suburban C2500		5
		92-99	GMC Suburban K1500		5
		92-99	GMC Suburban K2500		5
		92-00	GMC Yukon		5
		99-00	GMC Yukon Denali		5
E7	118323	91-95	Chrysler Town & Country	1	10
		91-95	Dodge Caravan		10
		03-10	Dodge Dakota		10

PC	PART NO.	YEARS	MAKE/MODEL	WGT LBS	IN		
E7	118323	91-95	Dodge Grand Caravan	1	10		
		06-09	Mitsubishi Raider		10		
		91-95	Plymouth Grand Voyager		10		
		91-95	Plymouth Voyager		10		
		11	RAM Dakota		10		
E12	118325	93-99	Ford Ranger	1	5		
		94-09	Mazda B2300		5		
		98-01	Mazda B2500		5		
		94-08	Mazda B3000		5		
		94-09	Mazda B4000		5		
E9	118326	92-97	Ford Crown Victoria		20		
		94-04	Ford Mustang Except Cobra SVT 99-04		20		
E1	118328	92-97	Mercury Grand Marquis		20		
		93-94	Dodge Van, B150		5		
		95-98	Dodge Van, B1500		5		
		93-94	Dodge Van, B250		5		
		95-98	Dodge Van, B2500		5		
		93-94	Dodge Van, B350		5		
		95-98	Dodge Van, B3500		5		
E7	118329	95-03	Dodge Dakota	1	5		
		95-01	Dodge Ram 1500		5		
		95-02	Dodge Ram 2500		5		
		95-02	Dodge Ram 3500		5		
		95-01	Dodge Ram 4000		5		
E7	118331	94-97	Honda Passport		5		
		92-97	Isuzu Rodeo		5		
E9	118333	96-99	Ford Taurus 4 Dr. Sedan	1	10		
		96-99	Mercury Sable Sedan		10		
E11	118334	96-00	Chrysler Town & Country	1	20		
		96-00	Dodge Caravan		20		
		98-03	Dodge Durango		20		
		96-00	Dodge Grand Caravan		20		
		96-00	Plymouth Grand Voyager		20		
		96-00	Plymouth Voyager		20		
		96-00	Plymouth Voyager		20		
E8	118335	96-99	Chevrolet Express 1500		20		
		96-99	Chevrolet Express 2500		20		
		96-99	Chevrolet Express 3500		20		
		96-99	GMC Savana 1500		20		
		96-99	GMC Savana 2500		20		
		96-99	GMC Savana 3500		20		
		96-99	GMC Savana 3500		20		
E5	118336	97-03	Acura CL	1	5		
		94-01	Acura Integra		5		
		01-06	Acura MDX		10		
		96-01	Acura RL		5		
		96-03	Acura TL		5		
		94-02	Honda Accord 4 Dr. Sedan		5		
		93-97	Honda Civic Del Sol		5		
		97-06	Honda CR-V		10		
		03-04	Honda Element		10		
		95-04	Honda Odyssey		10		
		03-08	Honda Pilot		10		
		01	Honda Prelude		5		
		96-99	Isuzu Oasis		10		
		E4	118338	87-95	Chevrolet G10		10
				87-95	Chevrolet G20		10
87-95	Chevrolet G30				10		
87-95	GMC G1500				10		
87-95	GMC G2500				10		
87-95	GMC G3500				10		
87-95	GMC G3500				10		
E5	118339	96-99	Acura SLX		5		
		92-02	Isuzu Trooper		5		
E11	118341	96-02	Toyota 4Runner	1	20		
E11	118343	92-94	Ford E-150 Econoline	1	10		
		92-94	Ford E-250 Econoline		10		
		92-94	Ford E-350 Econoline		10		
		01-03	Ford Escape		10		
		01-03	Mazda Tribute		10		
		01-03	Mazda Tribute		10		
E5	118344	97	Ford Aerostar Extended Body	1	10		
		97	Ford Aerostar Standard Body		10		
		95-02	Ford E-150 Econoline		10		
		95-02	Ford E-250 Econoline		10		
		95-02	Ford E-350 Econoline		10		
		97-99	Ford Escort 4 Dr. Sedan		10		
		98-03	Ford Escort ZX2		10		
		00-03	Ford Excursion		10		
		97-03	Ford Expedition		10		
		01-03	Ford Explorer 2 Dr. Sport		10		

PC	PART NO.	YEARS	MAKE/MODEL	WGT LBS	IN
E5	118344	02-03	Ford Explorer 4 Dr.	1	10
		02-03	Ford Explorer Sport Trac		10
		97-03	Ford F-150 Flareside		10
		04	Ford F-150 Heritage Flareside		10
		00-03	Ford F-150 SuperCrew		10
		00-03	Ford Focus Wagon (Built Before 11/2002)		10
		00-03	Ford Ranger		10
		03-04	Lincoln Aviator		10
		98-03	Lincoln Navigator		10
		02-03	Mercury Mountaineer		10
		97-99	Mercury Tracer 4 Dr. Sedan		10
E16	118345	92-94	Ford E-150 Econoline	2	45
		92-94	Ford E-250 Econoline		45
		92-94	Ford E-350 Econoline		45
		01-03	Ford Escape		45
		95-00	Ford Explorer		45
		01	Ford Explorer 4 Dr.		45
		01-03	Mazda Tribute		45
97-01	Mercury Mountaineer		45		
E16	118349	94-98	Jeep Grand Cherokee	1	45
E8	118353	86-94	Nissan D21 (App. starts with 86-1/2)	1	10
		87-95	Nissan Pathfinder		10
E8	118354	97-01	Jeep Cherokee	1	20
E8	118355	97-05	Chevrolet Venture	1	10
		97-04	Oldsmobile Silhouette		10
		99-05	Pontiac Montana		10
		07-09	Pontiac Montana (Canada Only)		10
E5	118356	97-98	Pontiac Trans Sport		10
		97	Jeep TJ (Canada Only)	1	10
E7	118357	91-97	Jeep Wrangler		10
		96-97	Lexus LX450		5
E10	118358	96-97	Toyota Land Cruiser		5
		97-01	Toyota Camry 4 Dr. Sedan	1	5
E4	118359	98-04	Chevrolet S10		5
		98-04	GMC Sonoma		5
		98-00	Isuzu Hombre		5
E17	118360	98-02	Honda Passport	1	15
		98-00	Isuzu Amigo		15
		98-04	Isuzu Rodeo		15
		01-03	Isuzu Rodeo Sport		15
E10	118361	97-03	Infiniti QX4	1	20
		98-01	Nissan Altima		20
		96-04	Nissan Pathfinder		20
E10	118362	98	Mercury Villager	1	5
		98-04	Nissan Frontier		5
		98	Nissan Quest		5
E12	118364	99-04	Chrysler 300M	1	15
		98-02	Chrysler Concorde		15
		98-04	Chrysler Intrepid (Canada Only)		15
		99	Chrysler LHS		15
E7	118365	98-04	Dodge Intrepid		15
		98-99	Lexus LX470	1	5
E19	118366	98-99	Toyota Land Cruiser		5
		99-03	Ford Windstar (Built Before 11/2002)	2	45
E15	118367	00	Toyota Tundra	1	10
E1	118368	99-00	Dodge Van, Ram 1500		5
		99-00	Dodge Van, Ram 2500		5
		99-00	Dodge Van, Ram 3500		5
E10	118369	99-04	Jeep Grand Cherokee	1	10
E5	118372	98-04	Chevrolet Tracker	1	5
		96-97	GEO Tracker		5
		99-05	Suzuki Grand Vitara		5
		89-98	Suzuki Sidekick		5
		99-04	Suzuki Vitara		5
		02-06	Suzuki XL-7		5
E17	118373	00-06	Lincoln LS	1	20
E4	118375	00-03	Ford Taurus 4 Dr. Sedan	1	10
		00-03	Mercury Sable Sedan		10
E8	118376	01-03	Chrysler Town & Country	1	15
		01-03	Chrysler Voyager		15
		01-03	Dodge Caravan		15
		01-03	Dodge Grand Caravan		15
E8	118377	00-02	Chevrolet Express 1500	1	10
		00-02	Chevrolet Express 2500		10
		00-02	Chevrolet Express 3500		10
		00-02	GMC Savana 1500		10
		00-02	GMC Savana 2500		10
		00-02	GMC Savana 3500		10

T-ONE® CONNECTOR INDEX

PC	PART NO.	YEARS	MAKE/MODEL	WGT LBS	IN
E8	118377	00-02	GMC Savana 3500	1	10
E17	118378	01-02	Toyota Tundra	1	10
E14	118379	89-95	Toyota Pickup Except T-100	1	10
		95-04	Toyota Tacoma (App. starts with 95-1/2)	10	
E12	118380	01-06	Mitsubishi Montero Except Montero Sport	1	20
E3	118381	07-08	Chrysler Aspen w/Factory 7-Way	5	
		04-08	Chrysler Pacifica w/Factory 7-Way	5	
		00-09	Dodge Dakota w/Factory 7-Way	5	
		00-08	Dodge Durango w/Factory 7-Way	5	
		00-08	Dodge Ram 1500 w/Factory 7-Way	5	
		00-09	Dodge Ram 2500 w/Factory 7-Way	5	
		00-09	Dodge Ram 3500 w/Factory 7-Way	5	
		03-09	Dodge Sprinter 2500 w/Factory 7-Way	5	
		03-09	Dodge Sprinter 3500 w/Factory 7-Way	5	
		01-03	Dodge Van, Ram 1500	5	
		01-03	Dodge Van, Ram 2500	5	
		01-03	Dodge Van, Ram 3500	5	
		03-09	Freightliner Sprinter 2500 w/Factory 7-Way	5	
		03-09	Freightliner Sprinter 3500 w/Factory 7-Way	5	
		06-10	Jeep Commander w/Factory 7-Way	5	
		00-10	Jeep Grand Cherokee w/Factory 7-Way	5	
		05-08	Jeep Liberty w/Factory 7-Way	5	
		06-09	Mitsubishi Raider w/Factory 7-Way	5	
E10	118383	02-07	Buick Rendezvous	1	20
		01-05	Pontiac Aztek	20	
E8	118384	08-12	Buick Enclave w/Factory 7-Way	1	5
		04-07	Buick Rainier w/Factory 7-Way	5	
		02-16	Cadillac Escalade	5	
		03-15	Cadillac Escalade ESV	5	
		02-11	Cadillac Escalade EXT w/Factory 7-Way	5	
		02-11	Chevrolet Avalanche 1500 w/Factory 7-Way	5	
		02-11	Chevrolet Avalanche 2500 w/Factory 7-Way	5	
		99-01	Chevrolet Blazer Downsize, w/Factory 7-Way	5	
		99-01	Chevrolet Blazer Trailblazer w/Factory 7-Way	5	
		04-12	Chevrolet Colorado w/Factory 7-Way	5	
		07-13	Chevrolet Silverado 1500	5	
		07	Chevrolet Silverado 1500 (Classic), w/Factory 7-Way	5	
		07	Chevrolet Silverado 1500 HD (Classic), w/Factory 7-Way	5	
		01-06	Chevrolet Silverado 1500 HD w/Factory 7-Way	5	
		14-19	Chevrolet Silverado 1500 LD (Old Body Style)	5	
		99-06	Chevrolet Silverado 1500 w/Factory 7-Way	5	
		07-18	Chevrolet Silverado 2500 HD	5	
		07	Chevrolet Silverado 2500 HD (Classic), w/Factory 7-Way	5	
		01-06	Chevrolet Silverado 2500 HD w/Factory 7-Way	5	
		99-04	Chevrolet Silverado 2500 w/Factory 7-Way	5	
		07	Chevrolet Silverado 3500 (Classic), w/Factory 7-Way	5	
		07-17	Chevrolet Silverado 3500 HD	5	
		01-06	Chevrolet Silverado 3500 w/Factory 7-Way	5	
		14-15	Chevrolet Suburban	5	
		00-14	Chevrolet Suburban 1500 w/Amber Turn Signals	5	
		00-13	Chevrolet Suburban 2500 w/Amber Turn Signals	5	
		00-11	Chevrolet Tahoe w/Amber Turn Signals	5	
		02-09	Chevrolet TrailBlazer w/Factory 7-Way	5	
		09-12	Chevrolet Traverse w/Factory 7-Way	5	
		09	Chrysler Aspen w/Factory 7-Way	5	
		09	Dodge Durango w/Factory 7-Way	5	
		09-10	Dodge Ram 1500 w/Factory 7-Way	5	
		10	Dodge Ram 2500 w/Factory 7-Way	5	
		10	Dodge Ram 3500 w/Factory 7-Way	5	
		07-12	GMC Acadia w/Factory 7-Way	5	
		04-12	GMC Canyon w/Factory 7-Way	5	
		02-09	GMC Envoy w/Factory 7-Way	5	
		99-01	GMC Jimmy Downsize, w/Factory 7-Way	5	
		07-18	GMC Sierra 1500	5	
		07	GMC Sierra 1500 (Classic), w/Factory 7-Way	5	
		07	GMC Sierra 1500 HD (Classic), w/Factory 7-Way	5	
		01-06	GMC Sierra 1500 HD w/Factory 7-Way	5	
		99-06	GMC Sierra 1500 w/Factory 7-Way	5	
		07-18	GMC Sierra 2500 HD	5	
		07	GMC Sierra 2500 HD (Classic), w/Factory 7-Way	5	
		11-12	GMC Sierra 2500 HD Denali HD	5	
		01-06	GMC Sierra 2500 HD w/Factory 7-Way	5	
		99-04	GMC Sierra 2500 w/Factory 7-Way	5	

PC	PART NO.	YEARS	MAKE/MODEL	WGT LBS	IN
E8	118384	07	GMC Sierra 3500 (Classic), w/Factory 7-Way	1	5
		07-17	GMC Sierra 3500 HD	5	
		01-06	GMC Sierra 3500 w/Factory 7-Way	5	
		00-16	GMC Yukon w/Amber Turn Signals	5	
		00-11	GMC Yukon XL 1500	5	
		00-11	GMC Yukon XL 2500	5	
		03-09	Hummer H2 w/Factory 7-Way	5	
		06-10	Hummer H3 w/Factory 7-Way	5	
		09-10	Hummer H3T w/Factory 7-Way	5	
		04-12	Infiniti QX56 w/Factory 7-Way	5	
		03-08	Isuzu Ascender w/Factory 7-Way	5	
		11-15	Jeep Grand Cherokee w/Factory 7-Way	5	
		09-12	Jeep Liberty w/Factory 7-Way	5	
		09-11	KIA Borrego w/Factory 7-Way	5	
		10-11	Lexus GX460 w/Factory 7-Way	5	
		05-14	Nissan Armada w/Factory 7-Way	5	
		04	Nissan Pathfinder Armada w/Factory 7-Way	5	
		04-14	Nissan Titan w/Factory 7-Way	5	
		98-04	Oldsmobile Bravada w/Factory 7-Way	5	
		11-17	RAM 1500 w/Factory 7-Way	5	
		11-19	RAM 2500 w/Factory 7-Way	5	
		11-17	RAM 3500 w/Factory 7-Way	5	
		05-09	Saab 9-7X w/Factory 7-Way	5	
		07-09	Saturn Outlook w/Factory 7-Way	5	
		10-11	Toyota 4Runner w/Factory 7-Way	5	
		09-13	Toyota Tacoma w/Factory 7-Way	5	
		10-17	Toyota Tundra w/Factory 7-Way	5	
		18-19	Volkswagen Atlas w/Factory 7-Way	5	
E17	118385	04-07	Ford Freestar	2	45
		04-07	Mercury Monterey	45	
E12	118386	00-02	Toyota Echo	1	20
		03-08	Toyota Matrix	20	
E13	118387	03	Toyota Corolla	1	15
E12	118388	96-00	Toyota RAV4	1	20
E12	118389	01-05	Toyota RAV4	1	20
E15	118390	07-09	Chrysler Aspen	2	45
		04-09	Dodge Durango	45	
E8	118391	05-06	Chevrolet Equinox	1	10
		06	Pontiac Torrent	10	
E5	118392	03-14	Chevrolet Express 1500	1	20
		03-18	Chevrolet Express 2500	20	
		03-18	Chevrolet Express 3500	20	
		03-14	GMC Savana 1500	20	
		03-18	GMC Savana 2500	20	
		03-18	GMC Savana 3500	20	
E17	118394	05-06	Jeep Grand Cherokee	1	20
E5	118395	05-07	Ford Five Hundred	10	
		05-07	Ford Freestyle	10	
E10	118396	05-07	Buick Terraza	1	15
		05-08	Chevrolet Uplander	15	
		09	Chevrolet Uplander (Canada Only)	15	
		05-06	Pontiac Montana SV6	15	
		07-09	Pontiac Montana SV6 (Canada Only)	15	
		05-07	Saturn Relay	15	
E16	118397	05-09	Hyundai Tucson	1	30
E8	118398	05-10	Chevrolet Cobalt 4 Dr.	1	10
		08	Chevrolet Cobalt Sport 4 Dr.	10	
		05-10	Chevrolet Cobalt SS 4 Dr.	10	
		05-06	Pontiac Pursuit 4 Dr. (Canada Only)	10	
E15	118400	06-08	Honda Ridgeline	1	10
E8	118401	05-10	KIA Sportage 6 Cyl.	1	5
E19	118402	05-08	Dodge Magnum	2	45
E7	118404	05-07	Chrysler 300 Except 300 C	1	10
		08-14	Dodge Challenger	10	
		06-10	Dodge Charger	10	
E16	118405	14-17	Mazda 3 4 Dr. Sedan	2	45
		14-18	Mazda 3 5 Dr. Hatchback	45	
		03-08	Mazda 6 4 Dr. Sedan	45	
		04-08	Mazda 6 5 Dr. Hatchback	45	
		07-12	Mazda CX-7	45	
		07-09	Toyota Camry 4 Dr. Sedan, Except Hybrid	45	
		12-19	Toyota Camry Including Hybrid	45	
		14-19	Toyota Corolla Except Hatchback	45	
		07-14	Toyota FJ Cruiser	45	
E14	118406	08-10	Chrysler 300	1	15
		05-07	Chrysler 300 C	15	
E5	118407	05-10	Chevrolet Cobalt 2 Dr.	1	15

PC	PART NO.	YEARS	MAKE/MODEL	WGT LBS	IN
E5	118407	08	Chevrolet Cobalt Sport 2 Dr.	1	15
		05-10	Chevrolet Cobalt SS 2 Dr.		15
		06-11	Chevrolet HHR		15
		08-10	Chevrolet HHR SS		15
		07-09	Pontiac G5 2 Dr.		15
		07-09	Pontiac G5 GT 2 Dr.		15
E16	118408	06-10	Jeep Commander	1	15
E7	118409	98-06	Jeep TJ (Canada Only)	1	15
		98-06	Jeep Wrangler		15
E19	118410	07-09	Hyundai Entourage	2	45
		06-14	KIA Sedona		45
E18	118411	05-14	Volvo XC90	2	20
E16	118412	06-12	Toyota RAV4	1	45
		08-10	Toyota Sequoia		45
E10	118413	06-11	Hyundai Azera	1	20
		01-07	Toyota Highlander Except Hybrid		20
E12	118414	04-06	Scion xB	1	20
E12	118415	07-12	Hyundai Santa Fe	1	20
		10-13	KIA Forte 4 Dr. Sedan		20
E5	118416	07-17	Jeep Wrangler Except w/Right Hand Drive & Limited Edition		10
		18	Jeep Wrangler JK Except w/Right Hand Drive & Limited Edition		10
E5	118417	06-13	Chevrolet Impala		10
E16	118418	02-07	Saturn Vue	1	20
E5	118419	06-11	Buick Lucerne	1	10
E14	118420	09-14	Acura TSX 4 Dr. Sedan	1	15
		08-12	Honda Accord Coupe		15
		08-12	Honda Accord Sedan		15
		06-15	Honda Civic 4 Dr. Sedan, Except Hybrid & Si		15
		07-13	Honda Fit		15
		04-13	Mazda 3 4 Dr. Sedan, Except w/Grand Touring LED Taillights		15
		04-13	Mazda 3 5 Dr. Hatchback, Except w/Grand Touring LED Taillights		15
07-12	Mitsubishi Galant		15		
E13	118421	07	Dodge Nitro	1	15
E14	118422	11-13	Ford Fiesta 4 Dr. Sedan	1	30
		06-12	Ford Fusion		30
E12	118423	07-09	Saturn Aura	1	15
E11	118424	07-13	Acura MDX	1	20
E7	118425	07-13	Jeep Grand Cherokee	1	20
E17	118426	05-07	Ford Escape	2	45
		05-06	Mazda Tribute		45
E8	118427	07-11	Honda CR-V	1	20
		07	Dodge Caliber	2	45
E18	118428	07-10	Jeep Compass		45
		07	Jeep Patriot		45
		07-10	KIA Rondo	1	15
E14	118431	11-12	KIA Rondo (Canada Only)		15
		10-19	KIA Soul Except w/LED Taillights		15
		07-09	Chevrolet Equinox	1	10
E7	118432	07-09	Pontiac Torrent		10
		07-09	Suzuki XL-7 w/Factory Tow Package		10
		07-10	Hyundai Elantra 4 Dr. Sedan	1	10
E12	118433	06-09	Hyundai Sonata		10
		09-10	KIA Optima		10
E10	118434	07-09	Saturn Outlook		15
E8	118436	06-07	Honda Accord 2 Dr. Coupe	1	10
E12	118437	06-15	Honda Civic 2 Dr. Coupe, Except Si	1	10
E12	118438	05-10	Honda Odyssey	1	20
E7	118439	08	Chevrolet Malibu Classic LS	1	15
		08	Chevrolet Malibu Classic LT		15
		04-07	Chevrolet Malibu LS 4 Dr. Sedan		15
		04-07	Chevrolet Malibu LT 4 Dr. Sedan		15
		04-07	Chevrolet Malibu Maxx LS		15
		04-07	Chevrolet Malibu Maxx LT		15
		06-07	Chevrolet Malibu SS 4 Dr. Sedan		15
		05-09	Pontiac G6		15
		03-07	Cadillac CTS	2	45
E15	118440	04-07	Cadillac CTS V		45
E11	118441	03-05	Honda Accord 2 Dr. Coupe	1	10
E19	118443	12-15	Chevrolet Captiva Sport	2	45
		08-09	Saturn Vue		45
E19	118444	07-10	Chrysler Sebring	2	45
		07-10	Chrysler Sebring Convertible		45
E19	118445	08-10	Dodge Avenger	2	45

PC	PART NO.	YEARS	MAKE/MODEL	WGT LBS	IN
E7	118447	08-09	Ford Taurus 4 Dr. Sedan		10
		08-09	Mercury Sable Sedan		10
E7	118448	08-09	Ford Taurus X		15
E13	118449	08-19	Toyota Highlander	1	20
E7	118450	08-12	Buick Enclave		10
		08-12	Chevrolet Malibu Except LTZ		10
		09-12	Chevrolet Traverse		10
		07-12	GMC Acadia	1	15
E11	118451	07-12	GMC Acadia	1	15
E7	118452	07-08	KIA Optima		10
E10	118453	07-09	KIA Amanti	1	10
		11-19	KIA Optima		10
E19	118454	07-16	Volvo S80 Sedan	2	45
E12	118456	06-12	Suzuki Grand Vitara	2	20
		07-11	Suzuki SX4 Crossover		20
E5	118457	08-11	Ford Focus	1	15
E11	118458	03-08	Pontiac Vibe	1	15
E16	118459	09-13	Toyota Corolla	2	45
E16	118460	09-10	Pontiac Vibe	2	45
		11-13	Scion xB		45
		09-13	Toyota Matrix		45
		06-07	Subaru B9 Tribeca	1	10
E12	118461	98-08	Subaru Forester		10
		05-07	Subaru Legacy Wagon		10
		96-99	Subaru Legacy Wagon, Outback		10
		00-09	Subaru Outback Wagon, Except Sport		10
		08-14	Subaru Tribeca		10
E19	118462	01-10	Chrysler PT Cruiser	2	45
		05-10	Chrysler PT Cruiser Convertible		45
E15	118463	08-10	Volvo V70 Wagon, Except w/Optional Power Operated Tailgate	2	45
		08-11	Subaru Impreza 4 Dr. Sedan	2	45
E14	118465	07-11	Honda Element	1	45
E15	118466	08-13	Cadillac CTS 4 Dr. Sedan	1	15
E11	118467	16-19	Subaru Crosstrek Except Hybrid	1	15
		09-19	Subaru Forester		15
		10-19	Subaru Outback Wagon, Except Sport		15
		13-15	Subaru XV Crosstrek Except Hybrid		15
		08-10	Scion xB	2	45
E18	118468	08-10	Scion xB	2	45
E16	118469	04-09	Nissan Quest	1	45
E17	118470	08-13	Nissan Altima Coupe	2	45
		07-15	Nissan Altima Sedan		45
		04-14	Nissan Maxima		45
		07-12	Nissan Sentra		45
E18	118471	11-13	Ford Fiesta 5 Dr. Hatchback	2	45
		09-12	Lincoln MKS		45
E8	118472	09-19	Ford Flex	1	15
E11	118473	09-12	Hyundai Elantra Touring 5 Dr.	1	15
		01-06	Hyundai Santa Fe		15
E18	118474	09	Dodge Journey	2	45
E12	118475	08-11	Suzuki SX4 Sport Sedan	1	20
E15	118476	09-11	Hyundai Genesis 4 Dr. Sedan	1	15
E17	118478	04-06	Lexus RX330	2	45
E7	118479	07-12	Lexus RX350		45
		05-09	Buick LaCrosse	1	10
E15	118480	07-08	Infiniti G35 4 Dr. Sedan	2	45
		09-13	Infiniti G37 4 Dr. Sedan		45
		08-13	Nissan Rogue Except Krom		45
		14-19	Nissan Rogue Except Sport		45
E17	118482	14	Nissan Rogue Select		45
		14-19	Mitsubishi Outlander Except Outlander Sport or PHEV	2	45
E19	118483	11-12	Toyota Avalon		45
		10-11	Toyota Camry 4 Dr. Sedan, Except Hybrid		45
		07-11	Toyota Camry Hybrid 4 Dr. Sedan		45
		09-16	Toyota Venza		45
		09-13	Mazda 6 4 Dr. Sedan	2	45
E13	118484	07-10	Scion tC	1	15
E13	118485	04-06	Chevrolet Aveo 4 Dr. Sedan	1	15
		04-11	Chevrolet Aveo 5 Dr. Hatchback		15
E17	118486	09	Pontiac G3 5 Dr.		15
		10-11	Chevrolet Camaro	1	15
E16	118487	10-17	Ford Mustang	2	45
E16	118488	07-12	Lexus ES350	2	45
E10	118489	04-08	Acura TL	1	10
E7	118490	09-12	Volkswagen Routan	1	20
E15	118491	09-11	Honda Pilot	1	20
		09-14	Honda Ridgeline		10

T-ONE® CONNECTOR INDEX

PC	PART NO.	YEARS	MAKE/MODEL	WGT LBS	IN
E15	118492	09-12	Nissan Cube	1	45
E16	118494	10-17	Chevrolet Equinox	2	45
		10-17	GMC Terrain		45
E8	118495	10	Dodge Journey	1	10
E13	118496	08-12	Toyota Hilux	1	10
		93-98	Toyota T100		10
		05-15	Toyota Tacoma		10
E18	118497	10-16	Buick LaCrosse	2	45
E18	118498	11-14	Toyota Sienna	2	45
		15-20	Toyota Sienna SE		45
E11	118500	07-12	Acura RDX	1	15
		10-11	Honda Accord Crosstour		15
		12	Honda Crosstour		15
E18	118501	10-18	Hyundai Tucson	1	45
E17	118502	07-09	Lincoln MKZ	2	45
		06	Lincoln Zephyr		45
		06-11	Mercury Milan		45
E13	118503	10-13	Acura ZDX	1	30
E18	118504	11-13	Buick Regal	2	45
E16	118505	04-15	Toyota Prius All Styles (Including Plug-In)	1	25
E23	118506	11-13	KIA Sorento Base I4	2	45
		11-13	KIA Sorento EX I4		45
		11-13	KIA Sorento EX V6, Except w/Factory Tow Package		45
		11-13	KIA Sorento LX I4		45
		11-13	KIA Sorento LX V6		45
E18	118507	10-14	Lincoln MKT	2	45
E19	118508	11-15	Chevrolet Cruze	2	45
		16	Chevrolet Cruze Limited Only (Old Body Style)		45
E24	118509	04-10	Volkswagen Touareg	2	45
E17	118510	10-12	Lexus HS250h Hybrid	2	20
E14	118511	10-14	Subaru Legacy Sedan	2	45
E5	118512	00-05	Chevrolet Impala	1	25
E12	118514	07-11	Chevrolet Aveo 4 Dr. Sedan	1	25
E21	118515	11-14	Ford Edge	2	45
E12	118516	04-11	Mitsubishi Endeavor	2	30
E18	118517	07-11	Toyota Yaris 4 Dr. Sedan	2	45
E18	118518	07-13	Mitsubishi Outlander Except Outlander Sport	1	45
E23	118519	11-15	Lincoln MKX	2	45
E17	118520	11-14	Mazda 2	2	45
		06-17	Mazda 5		45
		07-15	Mazda CX-9		45
E17	118521	11-17	Honda Odyssey	1	30
E16	118522	10-12	Hyundai Genesis 2 Dr. Coupe	2	45
E20	118524	02-07	Jeep Liberty	2	45
E14	118525	05-19	Nissan Frontier	1	30
		05-07	Nissan Pathfinder		30
		08-12	Nissan Pathfinder Except w/Factory 4-Flat		30
		05-15	Nissan Xterra		30
		09-12	Suzuki Equator		30
E25	118526	11-16	KIA Sportage	2	45
E17	118528	11-17	Nissan JUKE	2	45
E22	118530	07-10	Volkswagen Passat Wagon	2	45
E16	118532	13-14	Hyundai Elantra 2 Dr. Coupe	2	45
		11-13	Hyundai Elantra 4 Dr. Sedan		45
E18	118534	11-16	Chrysler Town & Country	2	45
		11-19	Dodge Grand Caravan		45
		12-15	RAM C/V Tradesman		45
E16	118535	06-11	Cadillac DTS	2	45
E17	118536	11-19	Dodge Journey w/LED Taillights	2	45
E19	118537	09-14	Acura TL	2	45
E16	118538	12-17	Mitsubishi Lancer 4 Dr. Sedan, Except Evolution, Ralliart & w/Dual Exhaust	2	45
		10-14	Mitsubishi Lancer 5 Dr. Hatchback, Except Ralliart & w/Dual Exhaust		45
		11-19	Mitsubishi Outlander Sport Except PHEV		45
		11-17	Mitsubishi RVR (Canada Only)		45
E20	118539	11-17	Jeep Compass (Old Body Style)	2	45
E11	118540	11-19	Ford Explorer	1	5
E21	118543	10-12	Lincoln MKZ	2	45
E17	118545	07-12	Nissan Versa 5 Dr. Hatchback	2	45
E20	118546	12-18	FIAT 500	2	45
E19	118547	11-17	Nissan Quest	1	45
E16	118548	16-18	Ford Focus RS	2	45
		12-18	Ford Focus Sedan		45
E18	118549	13-14	Ford Focus 5 Dr. Hatchback	2	45
		12-14	Ford Focus 5 Dr. Hatchback, Except ST w/Center Exhaust		45

PC	PART NO.	YEARS	MAKE/MODEL	WGT LBS	IN
E18	118550	11	Chrysler 200 4 Dr. Sedan	2	45
		11	Chrysler 200 Convertible		45
		11	Dodge Avenger		45
E17	118551	08-14	Ford E-150 Econoline	2	45
		08-14	Ford E-250 Econoline		45
		08-14	Ford E-350 Econoline Super Duty		45
		07-10	Ford Edge		45
		08-12	Ford Escape		45
		07-10	Lincoln MKX		45
		08-11	Mazda Tribute		45
		05-11	Mercury Mariner		45
E18	118552	08-10	Chrysler Town & Country	2	45
		08-12	Dodge Caliber		45
		11-13	Dodge Durango		45
		08-10	Dodge Grand Caravan		45
		08-17	Jeep Patriot		45
E17	118553	12-19	Nissan NV1500	2	45
		12-19	Nissan NV2500		45
		12-19	Nissan NV3500		45
E19	118554	07-11	Dodge Nitro	2	45
		08-12	Jeep Liberty		45
E16	118556	12-15	Chevrolet Camaro	1	30
E16	118557	10	Hyundai Sonata	2	45
		11-14	Hyundai Sonata Except Hybrid		45
E25	118558	12-15	Honda Pilot	1	30
E16	118559	12-17	Hyundai Accent 4 Dr. Sedan	2	45
E19	118560	11-14	Dodge Charger	1	25
E17	118561	12-16	Honda CR-V	1	45
E25	118562	06-10	Volkswagen Passat 4 Dr. Sedan	2	45
E19	118563	13-16	Mazda CX-5	1	45
E17	118564	12-17	Buick Verano	2	45
E16	118565	12	Chevrolet Orlando (Canada Only)	2	45
E18	118566	13-16	Ford Escape	2	45
E14	118567	12-19	Dodge Journey Except w/LED Taillights	2	45
E16	118568	13-16	Dodge Dart	2	25
E14	118569	13-18	Acura RDX	1	15
E16	118570	12-17	KIA Rio 4 Dr. Sedan	2	45
		12-16	KIA Rio 5 Dr. Hatchback		45
E18	118571	13-18	Hyundai Santa Fe Sport (5 Passenger)	2	45
E27	118572	11-18	Volkswagen Jetta 4 Dr. Sedan	2	45
E19	118573	12-16	Subaru Impreza 5 Dr. Wagon, Except WRX STi	2	45
E16	118574	13-19	Ford Fusion	2	45
E19	118575	13-15	Chevrolet Spark	1	45
E16	118576	13	Chevrolet Malibu Except LTZ & Canada Models	2	45
E17	118577	12-14	Chrysler 200 4 Dr. Sedan	2	45
		12-14	Chrysler 200 Convertible		45
		12-14	Dodge Avenger		45
E16	118578	13-18	Toyota Avalon	2	45
		13-18	Toyota RAV4		45
E15	118580	13-19	Cadillac ATS	2	25
E15	118581	12-16	Subaru Impreza 4 Dr. Sedan, Except WRX & WRX STi	1	45
E16	118582	13-19	Nissan Sentra	2	45
		14-18	Nissan Versa Note		45
E16	118583	14-19	KIA Sorento w/ I4 Engine	2	45
E26	118585	10-13	Ford Transit Connect	2	45
E15	118586	13-15	Honda Accord Coupe, w/LED Taillights	2	45
		13-15	Honda Accord Sedan, w/LED Taillights		45
E17	118587	14-19	Mazda 6 4 Dr. Sedan	2	45
E16	118588	13-16	Buick Encore	2	45
E14	118590	14-19	Chevrolet Impala Except Impala Limited	1	45
E17	118591	13-19	Lincoln MKZ	2	45
E17	118592	13-16	Lexus ES300h Hybrid	2	45
		13-18	Lexus ES350		45
E16	118593	09-12	Infiniti FX35	2	45
		13	Infiniti FX37		45
		09-13	Infiniti FX50		45
E15	118594	14-18	KIA Forte 4 Dr. Sedan	2	45
E15	118595	12-17	Hyundai Azera	2	45
E16	118596	13-15	Honda Accord Coupe, Except w/LED Taillights	2	45
		13-15	Honda Accord Sedan, Except w/LED Taillights		45
E17	118597	15-17	Chevrolet City Express	1	45
		13-17	Nissan NV200		45
E17	118598	13-14	Lexus GS350	2	45
		13	Lexus GS450h		45
E15	118599	20	Ford Explorer		45
		10-19	Ford Taurus 4 Dr. Sedan		45
		13-16	Lincoln MKS		45

PC	PART NO.	YEARS	MAKE/MODEL	WGT LBS	IN
E16	118600	11-14	Chrysler 300	1	25
		11-14	Chrysler 300 C		25
E17	118602	16	Chevrolet Malibu Limited LTZ, Except Canada Models (Old Body Style)	2	45
		13-15	Chevrolet Malibu LTZ Except Canada Models		45
E18	118604	13	Chevrolet Malibu (Canada Only), Except LTZ	2	45
		14-15	Chevrolet Malibu Except LTZ		45
		16	Chevrolet Malibu Limited, Except LTZ (Old Body Style)		45
E18	118605	14-18	Jeep Cherokee	2	45
E16	118609	09-13	Lexus IS250	2	45
		09-14	Lexus IS350		45
E13	118610	12-17	Toyota Prius V	2	45
E15	118611†	14-15	FIAT 500L	2	25
E14	118613	14-19	Ford Transit Connect	1	45
E18	118615	14	Scion tC	2	45
E16	118617	14-19	Dodge Durango	2	45
E18	118618	14-19	RAM ProMaster 1500 All Models	2	45
		14-19	RAM ProMaster 2500 All Models		45
		14-19	RAM ProMaster 3500 All Models		45
E1	118624	12-14	Land Rover Range Rover Evoque	2	10
E16	118626	14-17	Acura RLX	2	45
E18	118627	13-19	Acura ILX	2	45
E11	118628	14-19	Acura MDX	2	20
E16	118629	13-16	Scion FR-S	2	45
		13-19	Subaru BRZ		45
		17-19	Subaru Impreza Sedan, Except WRX & WRX STi		45
E17	118637	10-19	KIA Soul w/LED Taillights	2	45
E15	118638	15-17	Chrysler 200 4 Dr. Sedan	2	45
E18	118639	14-17	Buick Regal	2	45
E19	118640	12-16	Chevrolet Sonic 4 Dr. Sedan	2	45
		12-16	Chevrolet Sonic 5 Dr. Hatchback		45
E15	118641	14-19	Ford Fiesta 5 Dr. Hatchback	1	45
E11	118642	13-15	Honda Crosstour	2	15
E16	118643	15-19	Ford Transit-150	3	45
		15-19	Ford Transit-250		45
		15-19	Ford Transit-350 Single Rear Wheel w/148" Wheelbase		45
E15	118644	15-17	Hyundai Sonata Except Hybrid	2	45
E15	118645	14-19	Cadillac CTS 4 Dr. Sedan	1	45
E20	118646	15-19	Volkswagen Golf Except Sportwagen and R Models	2	45
		12-15	Volkswagen Passat		45
E16	118647	15-17	Volvo V60 (App. starts with 2015-1/2)	2	45
E16	118648	15-20	Toyota Sienna Except SE	2	45
E19	118649	14-19	Mercedes-Benz Sprinter 2500	2	45
		14-19	Mercedes-Benz Sprinter 3500		45
E17	118650	07-09	Dodge Sprinter 2500	2	45
		07-09	Dodge Sprinter 3500		45
		07-13	Freightliner Sprinter 2500		45
		07-13	Freightliner Sprinter 3500		45
		07-09	Mercedes-Benz Sprinter		45
		10-13	Mercedes-Benz Sprinter 2500		45
		10-13	Mercedes-Benz Sprinter 3500		45
E26	118651	15-18	Jeep Renegade	2	45
E17	118652	15-17	Lexus NX200t	2	45
		15	Lexus NX300h		45
E15	118653	09-14	Nissan Murano Except CrossCabriolet	1	20
E16	118654	12-16	Ford Ranger	2	45
E15	118655	15-19	Dodge Charger	30	
E16	118656	15-19	Dodge Challenger	1	30
E15	118658	15-19	Chrysler 300	3	20
E16	118659	13-16	Chevrolet Trax	2	45
		17-19	Chevrolet Trax LS		45
E15	118660	15-19	Nissan Murano Except CrossCabriolet	1	20
E16	118661	15-18	Toyota Yaris	1	45
E14	118663	11-16	Hyundai Sonata Hybrid	1	45
E22	118667	05-10	Volkswagen Jetta 4 Dr. Sedan	2	45
E18	118668	11-17	Volkswagen Touareg	2	45
E16	118669	15-18	Ford Edge Except Sport & Titanium Models	2	45
E20	118670	14-19	Infiniti QX60	1	30
		13-19	Nissan Pathfinder		30
E15	118671	15-18	Subaru Legacy	2	45
E15	118672	14-19	Infiniti Q50	2	45
E14	118673	16-19	Honda HR-V	2	45
E18	118674	15-18	Ford Focus 5 Dr. Hatchback, Except RS	2	45
E20	118675	12-17	Volkswagen Tiguan	2	45
		18	Volkswagen Tiguan Limited		45

PC	PART NO.	YEARS	MAKE/MODEL	WGT LBS	IN
E15	118676	16-19	Nissan Maxima	2	45
E14	118677	15-18	Ford Edge Titanium and Sport Models Only	2	45
E15	118678	16	Hyundai Elantra 4 Dr. Limited Models Only	2	45
E13	118680	12-19	Toyota Prius C		25
E1	118681	14-17	Land Rover Range Rover Sport		10
		15	Land Rover Range Rover w/Factory Tow Package		10
E18	118682	17-19	Lincoln Continental	2	45
		16-18	Lincoln MKX		45
E14	118683	17-18	Volvo S90	1	20
		16-19	Volvo XC90		20
E16	118684	16-17	Honda Accord Sedan	2	45
E21	118685	16-19	Toyota Tacoma	2	45
E19	118686	16-19	Honda Civic Sedan	2	45
E16	118687	15-19	Land Rover Discovery Sport	2	45
E17	118688	12-19	Volkswagen Beetle	2	45
E17	118689	16-19	Chevrolet Malibu Except Premier (New Body Style)	2	45
E17	118690	16-18	Chevrolet Camaro	2	45
E15	118692	17-20	Hyundai Elantra 4 Dr. Except Limited Models	2	45
		13-17	Hyundai Elantra GT Except for Korean Manufactured Vehicles		45
E24	118693	16-19	FIAT 500X	2	45
E18	118694	16-19	Chevrolet Spark	2	45
E17	118695	16	Honda Accord Coupe	2	45
E14	118696	16-19	Chevrolet Cruze (New Body Style)	2	45
E18	118697	16-19	Acura TLX	2	45
E17	118698	17-19	KIA Sportage	2	45
E17	118701	16-19	Toyota Prius Except Prius Prime	2	45
E15	118711	17	Hyundai Elantra 4 Dr. Limited Models	2	45
E15	118712	17-19	Chrysler Pacifica Limited	2	45
		17-19	Chrysler Pacifica Touring L		45
		17-19	Chrysler Pacifica Touring L Plus		45
		17-19	Chrysler Pacifica Touring Plus		45
E23	118713	16-18	BMW 320i	2	45
		16	BMW 320i xDrive		45
		16	BMW 328d		45
		16	BMW 328d xDrive		45
		16	BMW 328i		45
		16	BMW 328i GT xDrive		45
		16	BMW 328i xDrive		45
		16	BMW 330e		45
16	BMW 330i		45		
16	BMW 340i		45		
16	BMW 340i xDrive		45		
E16	118714	13-17	Volkswagen CC	2	45
E17	118715	17-18	Ford Escape	2	45
E23	118717	15-17	BMW X1	2	45
E14	118718	16-19	Mazda CX-3	2	45
E18	118719	15-19	RAM ProMaster City	2	45
E20	118721	17-19	Volkswagen Passat	2	45
		16	Volkswagen Passat Except SE & SEL		45
E18	118722	15-19	Ford Transit-350 Except Single Rear Wheel w/148" Wheelbase	3	45
E18	118723	17-19	Chrysler Pacifica LX	2	45
		17-19	Chrysler Pacifica Touring		45
E19	118724	16	Honda Civic Coupe	2	45
E5	118725	16-19	Buick Envision		15
E17	118726	17-19	Chevrolet Volt	2	45
E18	118727	14-19	Jeep Grand Cherokee	2	45
E15	118728	16	Scion iA	2	45
		17-18	Toyota Yaris iA		45
E16	118729	16	Scion iM	2	45
		19	Toyota Corolla Hatchback		45
		17-18	Toyota Corolla iM		45
E17	118730	17	Volkswagen Golf Alltrack	1	45
		16-17	Volkswagen Golf SportWagen		45
E15	118731	16-19	Nissan Altima Sedan	16	45
E17	118732	16	Cadillac CT6	1	25
E15	118733	17-19	Buick LaCrosse	2	45
E23	118734	17-19	Chevrolet Cruze Hatchback	2	45
E15	118736	17	Infiniti QX30	2	45
E13	118738	17-18	Genesis G80	2	25
		15-16	Hyundai Genesis Sedan		25
E15	118739	10-17	Volvo XC60	2	45
E15	118740	16-19	Chevrolet Malibu Premier (New Body Style)	2	45
E11	118741	17-19	Honda CR-V	2	30
E20	118742	16	Volkswagen Passat SE & SEL Only	2	45
E17	118744	17-19	Subaru Impreza Hatchback	2	45

T-ONE® CONNECTOR INDEX

PC	PART NO.	YEARS	MAKE/MODEL	WGT LBS	IN
E16	118745	17-19	Buick Encore	2	45
E15	118746	17-19	Mazda CX-5	2	45
E16	118747	17-18	Mercedes-Benz GLC250 SUV, Except P03 Premium Package	2	45
		16-18	Mercedes-Benz GLC300 SUV, Except P03 Premium Package		45
		18	Mercedes-Benz GLC350e SUV, Except P03 Premium Package		45
		17-18	Mercedes-Benz GLC43 AMG SUV, Except P03 Premium Package		45
		18	Mercedes-Benz GLC63 AMG S SUV, Except P03 Premium Package		45
		18	Mercedes-Benz GLC63 AMG SUV, Except P03 Premium Package		45
E15	118749	17-19	KIA Niro Except Plug-In-Hybrid	2	45
E17	118750	18-20	Chevrolet Equinox Except Premier	2	45
E16	118751	17-19	Chevrolet Trax Except LS	2	45
E20	118752	17-19	Jeep Compass (New Body Style)	2	45
E13	118753	18-19	Honda Odyssey Without Fuse Provisions	2	25
E19	118754	18-19	Volkswagen Atlas	2	45
E17	118755	17	Chevrolet Sonic 4 Dr. Sedan	2	45
		17-19	Chevrolet Sonic 5 Dr. Hatchback		45
E17	118756	18	Toyota C-HR	2	45
E15	118757	17-19	Nissan Rogue Sport	2	45
E14	118758	17	Hyundai Ioniq	2	45
E15	118759	18-20	Chevrolet Equinox Premier	2	45
E17	118760	16-19	Honda Pilot	4	20
E4	118761	18-19	Buick Enclave		20
		18-19	Chevrolet Traverse		20
E15	118762	18-19	Hyundai Sonata	2	45
E15	118763	18-19	Toyota Camry	2	45
E17	118764	18-19	GMC Terrain Without Relay Provisions	2	45
E14	118766	14-19	Ford Fiesta 4 Dr. Sedan	1	45
E23	118767	14-19	Honda Fit	2	45
E15	118768	18	Subaru WRX	2	45
E15	118769	14-15	Mitsubishi Mirage	1	45
		17-18	Mitsubishi Mirage Except Mirage G4		45
		17	Mitsubishi Mirage G4		45
E15	118770	14-18	Volvo S60 Sedan	2	45
E15	118771	13-17	Hyundai Accent 5 Dr. Hatchback	1	45
E17	118772	14-17	FIAT 500L	2	45
E16	118773	18-19	Volvo XC60	2	45
E17	118774	08-16	Volvo XC70	2	20
E17	118775	06-07	Nissan Murano	2	45
E15	118776	18-19	Honda Accord	2	45
E22	118777	18	Alfa Romeo Stelvio	2	45
E10	118778	17-18	Honda Ridgeline	1	20
E17	118779	19	Jeep Cherokee	2	45
E18	118780	18	KIA Stinger	2	45
E11	118781	18-19	Honda Odyssey With Fuse Provisions		20
E16	118783	18-19	Buick Regal Sportback	2	45
		18-19	Buick Regal TourX		45
E11	118784	20	Hyundai Palisade	1	15
		19	Hyundai Santa Fe Except XL Models		15
		20	KIA Telluride		15
E16	118785	17-19	Jaguar F-Pace	2	45
		18-19	Land Rover Range Rover Velar		45
E21	118786	20	Jeep Gladiator	2	45
		18-19	Jeep Wrangler JL (New Body Style)		45
E19	118787	18	Volkswagen Golf R	2	45
E17	118788	18-19	Jaguar E-Pace	2	45
E21	118789	18	BMW X2	2	45
E10	118790	19	Subaru Ascent	1	15
E22	118791	19	Volkswagen Jetta	2	45
E15	118792	19	Volvo XC40	2	45
E16	118793	18-19	KIA Rio Sedan	2	45
E19	118794	18	Nissan Kicks	2	45
E3	118795	19	Cadillac XT4	2	15
E18	118796	19	Infiniti QX50	2	45
E16	118798	19	Toyota Avalon	2	45
E12	118800	19-20	Acura RDX With +12V Power Provision	1	25
E16	118801	19	Toyota RAV4	2	45
E17	118802	19	Ford Escape	2	45
E23	118803	19	Lincoln Nautilus	2	45
E13	118804	19-20	Acura RDX Without +12V Power Provision	2	45
E20	118805	19	Ford Edge Except Titanium Models	2	45
E19	118806	19	Ford Edge Titanium Models Only	2	45

PC	PART NO.	YEARS	MAKE/MODEL	WGT LBS	IN
E16	118808	19	Mazda 3 Hatchback	2	45
		19	Mazda 3 Sedan		45
E14	118809	19	Honda Passport	2	25
E17	118810	20	Toyota Corolla Sedan	2	45
E17	118811	18-19	Volkswagen Tiguan	2	45
E19	118813	20	KIA Soul Except w/LED Taillights	2	45
		10-19	KIA Soul w/LED Taillights		45
TOW HARNESS					
E1	118240	96-03	Chevrolet Express 1500 w/Factory Tow Package		5
		96-03	Chevrolet Express 2500 w/Factory Tow Package		5
		96-03	Chevrolet Express 3500 w/Factory Tow Package		5
		96-03	GMC Savana 1500 w/Factory Tow Package		5
		96-03	GMC Savana 2500 w/Factory Tow Package		5
		96-03	GMC Savana 3500 w/Factory Tow Package		5
E3	118241	95-01	Ford Explorer w/Factory Tow Package		5
		98-99	Ford Ranger w/Factory Tow Package		5
		98-01	Mazda B2500 w/Factory Tow Package		5
		98-01	Mazda B3000 w/Factory Tow Package		5
		98-01	Mazda B4000 w/Factory Tow Package		5
		97-01	Mercury Mountaineer w/Factory Tow Package		5
E19	118242	04	Ford F-150 Heritage w/Factory 4-Flat	1	5
		97-03	Ford F-150 w/Factory 4-Flat		5
		97-99	Ford F-250 Styleside, w/Factory 4-Flat		5
E15	118243	99-01	Ford F-250 Super Duty w/Factory 4-Flat	1	5
		99-01	Ford F-350 Super Duty w/Factory 4-Flat		5
		99-01	Ford F-450 Super Duty w/Factory 4-Flat		5
		99-01	Ford F-550 Super Duty w/Factory 4-Flat		5
E1	118244	00-04	Nissan Xterra w/Factory Tow Package		5
E3	118245	01-07	Lexus LX470		10
		08-11	Lexus LX570		10
		01-03	Lexus RX300		10
		01-02	Toyota 4Runner		10
		01-03	Toyota Highlander		10
		01-02	Toyota Land Cruiser		10
E1	118246	01-02	Toyota Sequoia		5
E19	118247	04	Ford F-150 w/Factory 4-Flat	1	5
E10	118248	04-07	Toyota Highlander	1	20
E12	118249	07-12	Mazda CX-7 w/Factory Tow Package	1	5
E1	118251	08-12	Ford Escape Except Vehicles w/Back Up Sensors	1	5
		08-11	Mazda Tribute		5
		08-11	Mercury Mariner		5
E3	118252	10-18	Lexus RX350 w/Factory Tow Package		5
		18	Lexus RX350L w/Factory Tow Package		5
		10-18	Lexus RX450h Hybrid, w/Factory Tow Package		5
E22	118253	09-11	Honda Pilot	1	20
		09-14	Honda Ridgeline		20
E13	118255	10-18	Lexus RX350 Except Without Factory Tow Prep Package	1	10
		18	Lexus RX350L With Factory Tow Prep Package		20
		10-18	Lexus RX450h Hybrid		20
E14	118258	07-12	Hyundai Santa Fe w/Factory Tow Package		25
E3	118259	10-16	Cadillac SRX w/Factory Tow Package		5
E3	118260	09-12	Ford E-150 Econoline w/Factory 4-Flat (Prepped Class I Towing Package)		10
		09-12	Ford E-250 Econoline w/Factory 4-Flat (Prepped Class I Towing Package)		10
		09-12	Ford E-350 Econoline Super Duty w/Factory 4-Flat (Prepped Class I Towing Package)		10
E14	118261	09-12	Ford E-150 Econoline w/Factory 7-Way (Prepped Class II Towing Package)	1	10
		09-12	Ford E-250 Econoline w/Factory 7-Way (Prepped Class II Towing Package)		10
		09-12	Ford E-350 Econoline Super Duty w/Factory 7-Way (Prepped Class II Towing Package)		10
E12	118262	10-14	Lexus GX460	1	10
		10-11	Toyota 4Runner		10
E3	118263	05-19	Nissan Frontier w/Factory Tow Package		5
		05-07	Nissan Pathfinder		5
		05-15	Nissan Xterra w/Factory Tow Package		5
		09-12	Suzuki Equator w/Factory Tow Package		5
E1	118264	10-17	Chevrolet Equinox w/Factory Tow Package	1	15
		10-17	GMC Terrain w/Factory Tow Package		15
E30	118265	12-15	Honda Pilot	2	30
E21	118266	05-19	Nissan Frontier	1	30
		05-07	Nissan Pathfinder		30
		08-12	Nissan Pathfinder Except w/Factory 4-Flat		30
		05-15	Nissan Xterra		30

TOW HARNESS INDEX

PC	PART NO.	YEARS	MAKE/MODEL	WGT LBS	IN
E21	118266	09-12	Suzuki Equator	1	30
E9	118267	05-19	Nissan Frontier w/Factory Tow Package	1	5
		05-07	Nissan Pathfinder		5
		08-12	Nissan Pathfinder Except w/Factory 4-Flat		5
		05-15	Nissan Xterra w/Factory Tow Package		5
		09-12	Suzuki Equator w/Factory Tow Package		5
		E13	118269	13-17	Hyundai Santa Fe (6/7 Passenger)
		14-18	Hyundai Santa Fe Sport (5 Passenger) w/Factory Tow Package		20
		13-18	Hyundai Santa Fe Sport w/Factory Tow Package (5 Passenger)		20
		19	Hyundai Santa Fe XL w/Factory Tow Package		20
		07-12	Hyundai Veracruz		20
		15-19	KIA Sedona		20
		11-13	KIA Sorento EX V6, w/Factory Tow Package		20
		11-13	KIA Sorento LX V6		20
		11-13	KIA Sorento LX V6 w/Factory Tow Package		20
		11-13	KIA Sorento SX V6		20
		14-19	KIA Sorento w/ V6 Engine		20
		07-09	KIA Sorento w/Factory Tow Package		20
E10	118270	13-17	Buick Enclave	1	20
		13-17	Chevrolet Traverse		20
		13-16	GMC Acadia		20
		17	GMC Acadia Limited		20
E16	118271	13-17	Buick Enclave	1	20
		13-17	Chevrolet Traverse		20
		13-16	GMC Acadia		20
		17	GMC Acadia Limited		20
E15	118272	11-19	Ford Explorer	1	20
E23	118273	14-15	Infiniti QX60	2	30
		13-19	Nissan Pathfinder		30
E8	118275	14-15	Land Rover Range Rover Sport	1	20
		15	Land Rover Range Rover w/Factory Tow Package		20
E9	118276	17-19	Cadillac XT5	1	10
		19	Chevrolet Blazer		10
		17-19	GMC Acadia		10
E12	118277	16-18	Mitsubishi Outlander Except Outlander Sport or PHEV	1	25
E9	118278	16-19	Mazda CX-9 w/Factory Tow Package	1	25
E21	118281	05-17	Nissan Frontier (Canada Only)	2	30
		05-07	Nissan Pathfinder (Canada Only)		30
		08-12	Nissan Pathfinder Except w/Factory 4-Flat (Canada Only)		30
		05-15	Nissan Xterra (Canada Only)		30
		09-12	Suzuki Equator (Canada Only)		30
E9	118282	05-17	Nissan Frontier w/Factory Tow Package (Canada Only)	2	5
		05-07	Nissan Pathfinder (Canada Only)		5
		08-12	Nissan Pathfinder Except w/Factory 4-Flat (Canada Only)		5
		05-15	Nissan Xterra w/Factory Tow Package (Canada Only)		5
		09-12	Suzuki Equator w/Factory Tow Package (Canada Only)		5
E15	118283	15-19	Ford F-150	2	25
E14	118284	15-17	Lincoln MKC	2	45
E6	118285	18-19	Chevrolet Equinox w/ Tow Prep Package	2	15
		18-19	GMC Terrain w/ Tow Prep Package		15
E21	118286	16-19	Honda Pilot	2	30
E9	118287	18-19	Buick Enclave	2	15
		18-19	Chevrolet Traverse		15
E14	118288	17-18	Honda Ridgeline	2	20
E23	118289	14-19	Acura MDX	2	30
E30	118290	19	Subaru Ascent	2	45
E25	118291	19	Honda Passport	2	25
E3	118290	17-19	Cadillac XT5		10
		19	Chevrolet Blazer		10
		17-19	GMC Acadia		10
	20135	07-08	Chrysler Aspen w/Factory 7-Way	1	10
		04-08	Chrysler Pacifica w/Factory 7-Way		10
		00-09	Dodge Dakota w/Factory 7-Way		10
		00-08	Dodge Durango w/Factory 7-Way		10
		00-08	Dodge Ram 1500 w/Factory 7-Way		10
		00-09	Dodge Ram 2500 w/Factory 7-Way		10
		00-09	Dodge Ram 3500 w/Factory 7-Way		10
		03-09	Dodge Sprinter 2500 w/Factory 7-Way		10
		03-09	Dodge Sprinter 3500 w/Factory 7-Way		10
		01-03	Dodge Van, Ram 1500 w/Factory 7-Way		10
		01-03	Dodge Van, Ram 2500 w/Factory 7-Way		10

PC	PART NO.	YEARS	MAKE/MODEL	WGT LBS	IN	
	20135	01-03	Dodge Van, Ram 3500 w/Factory 7-Way	1	10	
		03-09	Freightliner Sprinter 2500 w/Factory 7-Way		10	
		03-09	Freightliner Sprinter 3500 w/Factory 7-Way		10	
		06-10	Jeep Commander w/Factory 7-Way		10	
		00-10	Jeep Grand Cherokee w/Factory 7-Way		10	
		05-08	Jeep Liberty w/Factory 7-Way		10	
		06-09	Mitsubishi Raider w/Factory 7-Way		10	
		03-06	Toyota Tundra w/Factory 7-Way		10	
		20137	03-06	Toyota Tundra w/Factory 7-Way	1	10
		E12	22111	08-12	Buick Enclave	1
09-12	Chevrolet Traverse				25	
	22112	14-18	RAM ProMaster 1500 All Models	4	60	
		14-19	RAM ProMaster 2500 All Models		60	
		14-19	RAM ProMaster 3500 All Models		60	
	22113	14-17	Dodge Durango	5	60	
	22114	15-19	Ford Transit-150	5	90	
		15-19	Ford Transit-250		90	
		15-19	Ford Transit-350 Single Rear Wheel w/148" Wheelbase		45	
	22115	14-17	Mercedes-Benz Sprinter 2500	7	90	
		14-17	Mercedes-Benz Sprinter 3500		90	
	22116	15-19	Ford Transit-350 Except Single Rear Wheel w/148" Wheelbase	3	90	
	22117	16-19	Toyota Tacoma	5	90	
	22119	14-19	Toyota Highlander	4	90	
	22121	11-16	Chrysler Town & Country	5	90	
		11-19	Dodge Grand Caravan		90	
		12-15	RAM C/V Tradesman		90	
E20	22124	19	Ford Ranger	2	45	
		74682	08-12	Buick Enclave w/Factory 7-Way	1	10
		04-07	Buick Rainier w/Factory 7-Way		10	
		03-15	Cadillac Escalade ESV w/Factory 7-Way		10	
		02-11	Cadillac Escalade EXT w/Factory 7-Way		10	
		02-16	Cadillac Escalade w/Factory 7-Way		10	
		02-06	Chevrolet Avalanche 1500 w/Factory 7-Way		10	
		02-06	Chevrolet Avalanche 2500 w/Factory 7-Way		10	
		07-11	Chevrolet Avalanche w/Factory 7-Way		10	
		99-01	Chevrolet Blazer Downsize, w/Factory 7-Way		10	
		99-01	Chevrolet Blazer Trailblazer w/Factory 7-Way		10	
		04-12	Chevrolet Colorado w/Factory 7-Way		10	
		07	Chevrolet Silverado 1500 (Classic), w/Factory 7-Way		10	
		07	Chevrolet Silverado 1500 HD (Classic), w/Factory 7-Way		10	
		01-06	Chevrolet Silverado 1500 HD w/Factory 7-Way		10	
		07-19	Chevrolet Silverado 1500 LD (Old Body Style) w/Factory 7-Way		10	
		99-06	Chevrolet Silverado 1500 w/Factory 7-Way		10	
		07	Chevrolet Silverado 2500 HD (Classic), w/Factory 7-Way		10	
		01-19	Chevrolet Silverado 2500 HD w/Factory 7-Way		10	
		99-04	Chevrolet Silverado 2500 w/Factory 7-Way		10	
		07	Chevrolet Silverado 3500 (Classic), w/Factory 7-Way		10	
		07-19	Chevrolet Silverado 3500 HD w/Factory 7-Way		10	
		01-06	Chevrolet Silverado 3500 w/Factory 7-Way		10	
		00-14	Chevrolet Suburban 1500 w/Amber Turn Signals, w/Factory 7-Way		10	
		00-13	Chevrolet Suburban 2500 w/Amber Turn Signals, w/Factory 7-Way		10	
		00-11	Chevrolet Tahoe w/Amber Turn Signals, w/Factory 7-Way		10	
		02-09	Chevrolet TrailBlazer w/Factory 7-Way		10	
		09-12	Chevrolet Traverse w/Factory 7-Way		10	
		09	Chrysler Aspen w/Factory 7-Way		10	
		09	Dodge Durango w/Factory 7-Way		10	
		09-10	Dodge Ram 1500 w/Factory 7-Way		10	
		10	Dodge Ram 2500 w/Factory 7-Way		10	
		10	Dodge Ram 3500 w/Factory 7-Way		10	
		97-09	Ford E-150 Econoline w/Factory 7-Way		10	
		97-09	Ford E-250 Econoline w/Factory 7-Way		10	
		97-09	Ford E-350 Econoline w/Factory 7-Way		10	
		00-05	Ford Excursion w/Factory 7-Way		10	
		97-15	Ford Expedition w/Factory 7-Way		10	
		00-03	Ford Explorer 2 Dr. Sport, w/Factory 7-Way		10	
		00-10	Ford Explorer 4 Dr., w/Factory 7-Way		10	
		07-10	Ford Explorer Sport Trac w/Factory 7-Way		10	
		11-19	Ford Explorer w/Factory 7-Way		10	

TOW HARNESS INDEX

PC	PART NO.	YEARS	MAKE/MODEL	WGT LBS	IN
	74682	97-19	Ford F-150 Flareside, w/Factory 7-Way	1	10
	04		Ford F-150 Heritage Flareside, w/Factory 7-Way		10
	04		Ford F-150 Heritage Styleside, w/Factory 7-Way		10
	97-19		Ford F-150 Styleside, w/Factory 7-Way		10
	00-19		Ford F-150 SuperCrew, w/Factory 7-Way		10
	97-99		Ford F-250 Styleside, w/Factory 7-Way		10
	99-19		Ford F-250 Super Duty w/Factory 7-Way		10
	99-19		Ford F-350 Super Duty w/Factory 7-Way		10
	99-15		Ford F-450 Super Duty w/Factory 7-Way		10
	99-11		Ford F-550 Super Duty w/Factory 7-Way		10
	09-19		Ford Flex w/Factory 7-Way		10
	00-11		Ford Ranger w/Factory 7-Way		10
	07-12		GMC Acadia w/Factory 7-Way		10
	04-12		GMC Canyon w/Factory 7-Way		10
	02-09		GMC Envoy w/Factory 7-Way		10
	99-01		GMC Jimmy Downsize, w/Factory 7-Way		10
	07		GMC Sierra 1500 (Classic), w/Factory 7-Way		10
	07		GMC Sierra 1500 HD (Classic), w/Factory 7-Way		10
	01-06		GMC Sierra 1500 HD w/Factory 7-Way		10
	99-18		GMC Sierra 1500 w/Factory 7-Way		10
	07		GMC Sierra 2500 HD (Classic), w/Factory 7-Way		10
	11-12		GMC Sierra 2500 HD Denali HD, w/Factory 7-Way		10
	01-19		GMC Sierra 2500 HD w/Factory 7-Way		10
	99-04		GMC Sierra 2500 w/Factory 7-Way		10
	07		GMC Sierra 3500 (Classic), w/Factory 7-Way		10
	07-19		GMC Sierra 3500 HD w/Factory 7-Way		10
	01-06		GMC Sierra 3500 w/Factory 7-Way		10
	01-17		GMC Yukon Denali w/Amber Turn Signals, w/Factory 7-Way		10
	00-17		GMC Yukon w/Amber Turn Signals, w/Factory 7-Way		10
	01-19		GMC Yukon XL 1500 Denali w/Factory 7-Way		10
	00-11		GMC Yukon XL 1500 w/Factory 7-Way		10
	00-13		GMC Yukon XL 2500 w/Factory 7-Way		10
	03-09		Hummer H2 w/Factory 7-Way		10
	06-10		Hummer H3 w/Factory 7-Way		10
	09-10		Hummer H3T w/Factory 7-Way		10
	04-12		Infiniti QX56 w/Factory 7-Way		10
	03-08		Isuzu Ascender w/Factory 7-Way		10
	11-15		Jeep Grand Cherokee w/Factory 7-Way		10
	09-12		Jeep Liberty w/Factory 7-Way		10
	09-11		KIA Borrego w/Factory 7-Way		10
	10-11		Lexus GX460 w/Factory 7-Way		10
	03-05		Lincoln Aviator w/Factory 7-Way		10
	06-08		Lincoln Mark LT w/Factory 7-Way		10
	10-12		Lincoln MKT w/Factory 7-Way		10
	98-11		Lincoln Navigator w/Factory 7-Way		10
	00-10		Mercury Mountaineer w/Factory 7-Way		10
	05-14		Nissan Armada w/Factory 7-Way		10
04		Nissan Pathfinder Armada w/Factory 7-Way		10	
04-14		Nissan Titan w/Factory 7-Way		10	
99-04		Oldsmobile Bravada w/Factory 7-Way		10	
11-17		RAM 1500 w/Factory 7-Way		10	
11-19		RAM 2500 w/Factory 7-Way		10	
11-17		RAM 3500 w/Factory 7-Way		10	
05-09		Saab 9-7X w/Factory 7-Way		10	
07-09		Saturn Outlook w/Factory 7-Way		10	
10-11		Toyota 4Runner w/Factory 7-Way		10	
09-12		Toyota Tacoma w/Factory 7-Way		10	
10-13		Toyota Tundra w/Factory 7-Way		10	
FIFTH WHEEL HARNESS					
	20110	07	Chevrolet Silverado 1500 (Classic), w/Factory 7-Way	3	45
	07		Chevrolet Silverado 1500 HD (Classic), w/Factory 7-Way		45
	01-06		Chevrolet Silverado 1500 HD w/Factory 7-Way		45
	07-19		Chevrolet Silverado 1500 LD (Old Body Style) w/Factory 7-Way		45
	99-06		Chevrolet Silverado 1500 w/Factory 7-Way		45
	07		Chevrolet Silverado 2500 HD (Classic), w/Factory 7-Way		45
	01-19		Chevrolet Silverado 2500 HD w/Factory 7-Way		45
	99-04		Chevrolet Silverado 2500 w/Factory 7-Way		45
	07		Chevrolet Silverado 3500 (Classic), w/Factory 7-Way		45
	07-19		Chevrolet Silverado 3500 HD w/Factory 7-Way		45
	99-04		Chevrolet Silverado 3500 w/Factory 7-Way		45
	07		Chevrolet Silverado 3500 (Classic), w/Factory 7-Way		45
	07-19		Chevrolet Silverado 3500 HD w/Factory 7-Way		45
	01-06		Chevrolet Silverado 3500 w/Factory 7-Way		45
	09-10		Dodge Ram 1500 w/Factory 7-Way		45

PC	PART NO.	YEARS	MAKE/MODEL	WGT LBS	IN
	20110	10	Dodge Ram 2500 w/Factory 7-Way	3	45
		10	Dodge Ram 3500 w/Factory 7-Way		45
		97-19	Ford F-150 Flareside, w/Factory 7-Way		45
		04	Ford F-150 Heritage Flareside, w/Factory 7-Way		45
		04	Ford F-150 Heritage Styleside, w/Factory 7-Way		45
		97-19	Ford F-150 Styleside, w/Factory 7-Way		45
		04-19	Ford F-150 SuperCrew, w/Factory 7-Way		45
		97-99	Ford F-250 Styleside, w/Factory 7-Way		45
		99-19	Ford F-250 Super Duty w/Factory 7-Way		45
		99-19	Ford F-350 Super Duty w/Factory 7-Way		45
		99-19	Ford F-450 Super Duty w/Factory 7-Way		45
		99-11	Ford F-550 Super Duty w/Factory 7-Way		45
		07	GMC Sierra 1500 (Classic), w/Factory 7-Way		45
		07	GMC Sierra 1500 HD (Classic), w/Factory 7-Way		45
		01-06	GMC Sierra 1500 HD w/Factory 7-Way		45
		07-19	GMC Sierra 1500 LD (Old Body Style) w/Factory 7-Way		45
		99-06	GMC Sierra 1500 w/Factory 7-Way		45
		07	GMC Sierra 2500 HD (Classic), w/Factory 7-Way		45
		11-12	GMC Sierra 2500 HD Denali HD, w/Factory 7-Way		45
		01-19	GMC Sierra 2500 HD w/Factory 7-Way		45
	99-04	GMC Sierra 2500 w/Factory 7-Way		45	
	07	GMC Sierra 3500 (Classic), w/Factory 7-Way		45	
	07-19	GMC Sierra 3500 HD w/Factory 7-Way		45	
	01-06	GMC Sierra 3500 w/Factory 7-Way		45	
	06-08	Lincoln Mark LT w/Factory 7-Way		45	
	04-14	Nissan Titan w/Factory 7-Way		45	
	11-17	RAM 1500 w/Factory 7-Way		45	
	11-18	RAM 2500 w/Factory 7-Way		45	
	11-17	RAM 3500 w/Factory 7-Way		45	
	10-16	Toyota Tundra w/Factory 7-Way		45	
	20111	00-08	Dodge Ram 1500 w/Factory 7-Way	2	45
		00-09	Dodge Ram 2500 w/Factory 7-Way		45
		00-09	Dodge Ram 3500 w/Factory 7-Way		45
	20113	07-09	Toyota Tundra w/Factory 7-Way	2	45
	20128	97-03	Ford F-150 Flareside, w/Factory 4-Flat	1	5
		04	Ford F-150 Heritage w/Factory 4-Flat		5
		97-03	Ford F-150 Styleside, w/Factory 4-Flat		5
		97-99	Ford F-250 Styleside, w/Factory 4-Flat		5
	20129	99-01	Ford F-250 Super Duty w/Factory 4-Flat	1	5
		99-01	Ford F-350 Super Duty w/Factory 4-Flat		5
		99-01	Ford F-450 Super Duty w/Factory 4-Flat		5
		99-01	Ford F-550 Super Duty w/Factory 4-Flat		5
	20130	97-03	Ford F-150 Flareside, w/Factory 4-Flat	2	5
		04	Ford F-150 Heritage w/Factory 4-Flat		5
		97-03	Ford F-150 Styleside, w/Factory 4-Flat		5
		97-99	Ford F-250 Styleside, w/Factory 4-Flat		5
	20131	99-01	Ford F-250 Super Duty w/Factory 4-Flat	2	5
99-01		Ford F-350 Super Duty w/Factory 4-Flat		5	
99-01		Ford F-450 Super Duty w/Factory 4-Flat		5	
99-01		Ford F-550 Super Duty w/Factory 4-Flat		5	
20140	07	Chevrolet Silverado 1500 (Classic), w/Factory 7-Way	2	45	
	07	Chevrolet Silverado 1500 HD (Classic), w/Factory 7-Way		45	
	01-06	Chevrolet Silverado 1500 HD w/Factory 7-Way		45	
	07-19	Chevrolet Silverado 1500 LD (Old Body Style) w/Factory 7-Way		45	
	99-06	Chevrolet Silverado 1500 w/Factory 7-Way		45	
	07	Chevrolet Silverado 2500 HD (Classic), w/Factory 7-Way		45	
	01-19	Chevrolet Silverado 2500 HD w/Factory 7-Way		45	
	99-04	Chevrolet Silverado 2500 w/Factory 7-Way		45	
	07	Chevrolet Silverado 3500 (Classic), w/Factory 7-Way		45	
	07-19	Chevrolet Silverado 3500 HD w/Factory 7-Way		45	
	01-06	Chevrolet Silverado 3500 w/Factory 7-Way		45	
	09-10	Dodge Ram 1500 w/Factory 7-Way		45	
	10	Dodge Ram 2500 w/Factory 7-Way		45	
	10	Dodge Ram 3500 w/Factory 7-Way		45	
	97-19	Ford F-150 Flareside, w/Factory 7-Way		45	
04	Ford F-150 Heritage Flareside, w/Factory 7-Way		45		
04	Ford F-150 Heritage Styleside, w/Factory 7-Way		45		
97-19	Ford F-150 Styleside, w/Factory 7-Way		45		
04-19	Ford F-150 SuperCrew, w/Factory 7-Way		45		
97-99	Ford F-250 Styleside, w/Factory 7-Way		45		
99-19	Ford F-250 Super Duty w/Factory 7-Way		45		

FIFTH WHEEL HARNESS INDEX

PC	PART NO.	YEARS	MAKE/MODEL	WGT LBS	IN			
51-97-410	07-19	07-19	GMC Sierra 1500 LD (Old Body Style) w/Factory 7-Way	4	45			
			99-06	GMC Sierra 1500 w/Factory 7-Way	45			
			07	GMC Sierra 2500 HD (Classic), w/Factory 7-Way	45			
			11-12	GMC Sierra 2500 HD Denali HD, w/Factory 7-Way	45			
			01-19	GMC Sierra 2500 HD w/Factory 7-Way	45			
			99-04	GMC Sierra 2500 w/Factory 7-Way	45			
			07	GMC Sierra 3500 (Classic), w/Factory 7-Way	45			
			07-19	GMC Sierra 3500 HD w/Factory 7-Way	45			
			01-06	GMC Sierra 3500 w/Factory 7-Way	45			
			06-08	Lincoln Mark LT w/Factory 7-Way	45			
			04-14	Nissan Titan w/Factory 7-Way	45			
			11-17	RAM 1500 w/Factory 7-Way	45			
			11-18	RAM 2500 w/Factory 7-Way	45			
			11-17	RAM 3500 w/Factory 7-Way	45			
			10-16	Toyota Tundra w/Factory 7-Way	45			
51-97-411	00-08	00-08	Dodge Ram 1500 w/Factory 7-Way	4	45			
			00-09	Dodge Ram 2500 w/Factory 7-Way	45			
			00-09	Dodge Ram 3500 w/Factory 7-Way	45			
51-97-412	07-09	07-09	Toyota Tundra w/Factory 7-Way	4	45			
54700-003	07	07	Chevrolet Silverado 1500 (Classic), w/Factory 7-Way	3	45			
			07	Chevrolet Silverado 1500 HD (Classic), w/Factory 7-Way	45			
			01-06	Chevrolet Silverado 1500 HD w/Factory 7-Way	45			
			07-19	Chevrolet Silverado 1500 LD (Old Body Style) w/Factory 7-Way	45			
			99-06	Chevrolet Silverado 1500 w/Factory 7-Way	45			
			07	Chevrolet Silverado 2500 HD (Classic), w/Factory 7-Way	45			
			01-19	Chevrolet Silverado 2500 HD w/Factory 7-Way	45			
			99-04	Chevrolet Silverado 2500 w/Factory 7-Way	45			
			07	Chevrolet Silverado 3500 (Classic), w/Factory 7-Way	45			
			07-19	Chevrolet Silverado 3500 HD w/Factory 7-Way	45			
			01-06	Chevrolet Silverado 3500 w/Factory 7-Way	45			
			09-10	Dodge Ram 1500 w/Factory 7-Way	45			
			10	Dodge Ram 2500 w/Factory 7-Way	45			
			10	Dodge Ram 3500 w/Factory 7-Way	45			
			97-19	Ford F-150 Flareside, w/Factory 7-Way	45			
			04	Ford F-150 Heritage Flareside, w/Factory 7-Way	45			
			04	Ford F-150 Heritage Styleside, w/Factory 7-Way	45			
			97-19	Ford F-150 Styleside, w/Factory 7-Way	45			
			04-19	Ford F-150 SuperCrew, w/Factory 7-Way	45			
			97-99	Ford F-250 Styleside, w/Factory 7-Way	45			
			99-19	Ford F-250 Super Duty w/Factory 7-Way	45			
			99-15	Ford F-350 Super Duty w/Factory 7-Way	45			
			99-15	Ford F-450 Super Duty w/Factory 7-Way	45			
			99-11	Ford F-550 Super Duty w/Factory 7-Way	45			
			07	GMC Sierra 1500 (Classic), w/Factory 7-Way	45			
			07	GMC Sierra 1500 HD (Classic), w/Factory 7-Way	45			
			01-06	GMC Sierra 1500 HD w/Factory 7-Way	45			
			07-19	GMC Sierra 1500 LD (Old Body Style) w/Factory 7-Way	45			
			99-06	GMC Sierra 1500 w/Factory 7-Way	45			
			07	GMC Sierra 2500 HD (Classic), w/Factory 7-Way	45			
			11-12	GMC Sierra 2500 HD Denali HD, w/Factory 7-Way	45			
			01-19	GMC Sierra 2500 HD w/Factory 7-Way	45			
			99-04	GMC Sierra 2500 w/Factory 7-Way	45			
			07	GMC Sierra 3500 (Classic), w/Factory 7-Way	45			
			07-19	GMC Sierra 3500 HD w/Factory 7-Way	45			
			01-06	GMC Sierra 3500 w/Factory 7-Way	45			
			06-08	Lincoln Mark LT w/Factory 7-Way	45			
			04-14	Nissan Titan w/Factory 7-Way	45			
			11-17	RAM 1500 w/Factory 7-Way	45			
			11-17	RAM 2500 w/Factory 7-Way	45			
			11-17	RAM 3500 w/Factory 7-Way	45			
			10-16	Toyota Tundra w/Factory 7-Way	45			
			54700-004	07-09	07-09	Toyota Tundra w/Factory 7-Way	3	45
			54700-007	11-19	11-19	Ford F-250 Super Duty w/Factory 7-Way	3	45
						11-19	Ford F-350 Super Duty w/Factory 7-Way	45
11-19	Ford F-450 Super Duty w/Factory 7-Way	45						
54700-009	11-19	11-19	Ford F-250 Super Duty w/Factory 7-Way	3	45			
			11-19	Ford F-350 Super Duty w/Factory 7-Way	45			
			11-19	Ford F-450 Super Duty w/Factory 7-Way	45			
54701-003	07	07	Chevrolet Silverado 1500 (Classic), w/Factory 7-Way	4	45			

PC	PART NO.	YEARS	MAKE/MODEL	WGT LBS	IN			
54701-003	07	07	Chevrolet Silverado 1500 HD (Classic), w/Factory 7-Way	4	45			
			01-06	Chevrolet Silverado 1500 HD w/Factory 7-Way	45			
			07-19	Chevrolet Silverado 1500 LD (Old Body Style) w/Factory 7-Way	45			
			99-06	Chevrolet Silverado 1500 w/Factory 7-Way	45			
			07	Chevrolet Silverado 2500 HD (Classic), w/Factory 7-Way	45			
			01-19	Chevrolet Silverado 2500 HD w/Factory 7-Way	45			
			99-04	Chevrolet Silverado 2500 w/Factory 7-Way	45			
			07	Chevrolet Silverado 3500 (Classic), w/Factory 7-Way	45			
			07-19	Chevrolet Silverado 3500 HD w/Factory 7-Way	45			
			01-06	Chevrolet Silverado 3500 w/Factory 7-Way	45			
			09-10	Dodge Ram 1500 w/Factory 7-Way	45			
			10	Dodge Ram 2500 w/Factory 7-Way	45			
			10	Dodge Ram 3500 w/Factory 7-Way	45			
			97-19	Ford F-150 Flareside, w/Factory 7-Way	45			
			04	Ford F-150 Heritage Flareside, w/Factory 7-Way	45			
			04	Ford F-150 Heritage Styleside, w/Factory 7-Way	45			
			97-19	Ford F-150 Styleside, w/Factory 7-Way	45			
			04-19	Ford F-150 SuperCrew, w/Factory 7-Way	45			
			97-99	Ford F-250 Styleside, w/Factory 7-Way	45			
			99-19	Ford F-250 Super Duty w/Factory 7-Way	45			
			99-15	Ford F-350 Super Duty w/Factory 7-Way	45			
			99-15	Ford F-450 Super Duty w/Factory 7-Way	45			
			99-11	Ford F-550 Super Duty w/Factory 7-Way	45			
			07	GMC Sierra 1500 (Classic), w/Factory 7-Way	45			
			07	GMC Sierra 1500 HD (Classic), w/Factory 7-Way	45			
			01-06	GMC Sierra 1500 HD w/Factory 7-Way	45			
			07-19	GMC Sierra 1500 LD (Old Body Style) w/Factory 7-Way	45			
			99-06	GMC Sierra 1500 w/Factory 7-Way	45			
			07	GMC Sierra 2500 HD (Classic), w/Factory 7-Way	45			
			11-12	GMC Sierra 2500 HD Denali HD, w/Factory 7-Way	45			
			01-19	GMC Sierra 2500 HD w/Factory 7-Way	45			
			99-04	GMC Sierra 2500 w/Factory 7-Way	45			
			07	GMC Sierra 3500 (Classic), w/Factory 7-Way	45			
			07-19	GMC Sierra 3500 HD w/Factory 7-Way	45			
			01-06	GMC Sierra 3500 w/Factory 7-Way	45			
			06-08	Lincoln Mark LT w/Factory 7-Way	45			
			04-14	Nissan Titan w/Factory 7-Way	45			
			11-17	RAM 1500 w/Factory 7-Way	45			
			11-17	RAM 2500 w/Factory 7-Way	45			
			11-17	RAM 3500 w/Factory 7-Way	45			
			10-16	Toyota Tundra w/Factory 7-Way	45			
			54701-004	07-09	07-09	Toyota Tundra w/Factory 7-Way	4	45
			54701-007	11-19	11-19	Ford F-250 Super Duty w/Factory 7-Way	3	45
						11-19	Ford F-350 Super Duty w/Factory 7-Way	45
						11-19	Ford F-450 Super Duty w/Factory 7-Way	45
54701-009	11-19	11-19	Ford F-250 Super Duty w/Factory 7-Way	3	45			
			11-19	Ford F-350 Super Duty w/Factory 7-Way	45			
			11-19	Ford F-450 Super Duty w/Factory 7-Way	45			
6 / 7-WAY CONNECTORS								
85219	08-12	08-12	Buick Enclave w/Factory 7-Way	1	10			
			04-07	Buick Rainier w/Factory 7-Way	10			
			03-15	Cadillac Escalade ESV w/Factory 7-Way	10			
			02-11	Cadillac Escalade EXT w/Factory 7-Way	10			
			02-16	Cadillac Escalade w/Factory 7-Way	10			
			02-06	Chevrolet Avalanche 1500 w/Factory 7-Way	10			
			02-06	Chevrolet Avalanche 2500 w/Factory 7-Way	10			
			07-11	Chevrolet Avalanche w/Factory 7-Way	10			
			99-01	Chevrolet Blazer Downsize, w/Factory 7-Way	10			
			99-01	Chevrolet Blazer Trailblazer w/Factory 7-Way	10			
			04-12	Chevrolet Colorado w/Factory 7-Way	10			
			07	Chevrolet Silverado 1500 (Classic), w/Factory 7-Way	10			
			07	Chevrolet Silverado 1500 HD (Classic), w/Factory 7-Way	10			
			01-06	Chevrolet Silverado 1500 HD w/Factory 7-Way	10			
			07-19	Chevrolet Silverado 1500 LD (Old Body Style) w/Factory 7-Way	10			
99-06	Chevrolet Silverado 1500 w/Factory 7-Way	10						
07	Chevrolet Silverado 2500 HD (Classic), w/Factory 7-Way	10						
01-19	Chevrolet Silverado 2500 HD w/Factory 7-Way	10						
99-04	Chevrolet Silverado 2500 w/Factory 7-Way	10						

6-WAY AND 7-WAY CONNECTOR INDEX

PC	PART NO.	YEARS	MAKE/MODEL	WGT LBS	IN
	85219	07	Chevrolet Silverado 3500 (Classic), w/Factory 7-Way	1	10
		07-19	Chevrolet Silverado 3500 HD w/Factory 7-Way		10
		01-06	Chevrolet Silverado 3500 w/Factory 7-Way		10
		00-14	Chevrolet Suburban 1500 w/Amber Turn Signals, w/Factory 7-Way		10
		00-13	Chevrolet Suburban 2500 w/Amber Turn Signals, w/Factory 7-Way		10
		00-11	Chevrolet Tahoe w/Amber Turn Signals, w/Factory 7-Way		10
		02-09	Chevrolet TrailBlazer w/Factory 7-Way		10
		09-12	Chevrolet Traverse w/Factory 7-Way		10
		09	Chrysler Aspen w/Factory 7-Way		10
		09	Dodge Durango w/Factory 7-Way		10
		09-10	Dodge Ram 1500 w/Factory 7-Way		10
		10	Dodge Ram 2500 w/Factory 7-Way		10
		10	Dodge Ram 3500 w/Factory 7-Way		10
		97-09	Ford E-150 Econoline w/Factory 7-Way		10
		97-09	Ford E-250 Econoline w/Factory 7-Way		10
		97-09	Ford E-350 Econoline w/Factory 7-Way		10
		00-05	Ford Excursion w/Factory 7-Way		10
		97-15	Ford Expedition w/Factory 7-Way		10
		01-03	Ford Explorer 2 Dr. Sport, w/Factory 7-Way		10
		00-10	Ford Explorer 4 Dr., w/Factory 7-Way		10
		07-10	Ford Explorer Sport Trac w/Factory 7-Way		10
		11-19	Ford Explorer w/Factory 7-Way		10
		04	Ford F-150 Heritage w/Factory 7-Way		10
		97-19	Ford F-150 w/Factory 7-Way		10
		97-99	Ford F-250 Styleside, w/Factory 7-Way		10
		99-19	Ford F-250 Super Duty w/Factory 7-Way		10
		99-19	Ford F-350 Super Duty w/Factory 7-Way		10
		99-15	Ford F-450 Super Duty w/Factory 7-Way		10
		99-11	Ford F-550 Super Duty w/Factory 7-Way		10
		09-19	Ford Flex w/Factory 7-Way		10
		00-11	Ford Ranger w/Factory 7-Way		10
		07-12	GMC Acadia w/Factory 7-Way		10
		04-12	GMC Canyon w/Factory 7-Way		10
		02-09	GMC Envoy w/Factory 7-Way		10
		99-01	GMC Jimmy Downsize, w/Factory 7-Way		10
		07	GMC Sierra 1500 (Classic), w/Factory 7-Way		10
		07	GMC Sierra 1500 HD (Classic), w/Factory 7-Way		10
		01-06	GMC Sierra 1500 HD w/Factory 7-Way		10
		99-18	GMC Sierra 1500 w/Factory 7-Way		10
		07	GMC Sierra 2500 HD (Classic), w/Factory 7-Way		10
		01-19	GMC Sierra 2500 HD w/Factory 7-Way		10
		99-04	GMC Sierra 2500 w/Factory 7-Way		10
		07	GMC Sierra 3500 (Classic), w/Factory 7-Way		10
		07-19	GMC Sierra 3500 HD w/Factory 7-Way		10
		01-06	GMC Sierra 3500 w/Factory 7-Way		10
		11-12	GMC Sierra Denali HD, w/Factory 7-Way		10
		00-17	GMC Yukon w/Amber Turn Signals, w/Factory 7-Way		10
		00-11	GMC Yukon XL 1500 w/Factory 7-Way		10
		00-13	GMC Yukon XL 2500 w/Factory 7-Way		10
		03-09	Hummer H2 w/Factory 7-Way		10
		06-10	Hummer H3 w/Factory 7-Way		10
		09-10	Hummer H3T w/Factory 7-Way		10
		04-12	Infiniti QX56 w/Factory 7-Way		10
		03-08	Isuzu Ascender w/Factory 7-Way		10
		11-15	Jeep Grand Cherokee w/Factory 7-Way		10
		09-12	Jeep Liberty w/Factory 7-Way		10
		09-11	KIA Borrego w/Factory 7-Way		10
		10-11	Lexus GX460 w/Factory 7-Way		10
		03-05	Lincoln Aviator w/Factory 7-Way		10
		06-08	Lincoln Mark LT w/Factory 7-Way		10
		10-12	Lincoln MKT w/Factory 7-Way		10
		98-11	Lincoln Navigator w/Factory 7-Way		10
		00-10	Mercury Mountaineer w/Factory 7-Way		10
		05-14	Nissan Armada w/Factory 7-Way		10
		04	Nissan Pathfinder Armada w/Factory 7-Way		10
		04-14	Nissan Titan w/Factory 7-Way		10
		99-04	Oldsmobile Bravada w/Factory 7-Way		10
		11-17	RAM 1500 w/Factory 7-Way		10
		11-19	RAM 2500 w/Factory 7-Way		10
		11-17	RAM 3500 w/Factory 7-Way		10
		05-09	Saab 9-7X w/Factory 7-Way		10
		07-09	Saturn Outlook w/Factory 7-Way		10
		10-11	Toyota 4Runner w/Factory 7-Way		10

PC	PART NO.	YEARS	MAKE/MODEL	WGT LBS	IN
	85219	09-12	Toyota Tacoma w/Factory 7-Way	1	10
		10-13	Toyota Tundra w/Factory 7-Way		10
	8551511	08-12	Buick Enclave w/Factory 7-Way	2	10
		04-07	Buick Rainier w/Factory 7-Way		10
		03-11	Cadillac Escalade ESV w/Factory 7-Way		10
		02-11	Cadillac Escalade EXT w/Factory 7-Way		10
		02-16	Cadillac Escalade w/Factory 7-Way		10
		02-06	Chevrolet Avalanche 1500 w/Factory 7-Way		10
		02-06	Chevrolet Avalanche 2500 w/Factory 7-Way		10
		07-11	Chevrolet Avalanche w/Factory 7-Way		10
		99-01	Chevrolet Blazer Downsize, w/Factory 7-Way		10
		99-01	Chevrolet Blazer Trailblazer w/Factory 7-Way		10
		04-12	Chevrolet Colorado w/Factory 7-Way		10
		07	Chevrolet Silverado 1500 (Classic), w/Factory 7-Way		10
		07	Chevrolet Silverado 1500 HD (Classic), w/Factory 7-Way		10
		01-06	Chevrolet Silverado 1500 HD w/Factory 7-Way		10
		07-19	Chevrolet Silverado 1500 LD (Old Body Style) w/Factory 7-Way		10
		99-06	Chevrolet Silverado 1500 w/Factory 7-Way		10
		07	Chevrolet Silverado 2500 HD (Classic), w/Factory 7-Way		10
		01-19	Chevrolet Silverado 2500 HD w/Factory 7-Way		10
		99-04	Chevrolet Silverado 2500 w/Factory 7-Way		10
		07	Chevrolet Silverado 3500 (Classic), w/Factory 7-Way		10
		07-19	Chevrolet Silverado 3500 HD w/Factory 7-Way		10
		01-06	Chevrolet Silverado 3500 w/Factory 7-Way		10
		00-14	Chevrolet Suburban 1500 w/Amber Turn Signals, w/Factory 7-Way		10
		00-13	Chevrolet Suburban 2500 w/Amber Turn Signals, w/Factory 7-Way		10
		00-11	Chevrolet Tahoe w/Amber Turn Signals, w/Factory 7-Way		10
		02-09	Chevrolet TrailBlazer w/Factory 7-Way		10
		09-12	Chevrolet Traverse w/Factory 7-Way		10
		07-12	GMC Acadia w/Factory 7-Way		10
		04-12	GMC Canyon w/Factory 7-Way		10
		02-09	GMC Envoy w/Factory 7-Way		10
		99-01	GMC Jimmy Downsize, w/Factory 7-Way		10
		07	GMC Sierra 1500 (Classic), w/Factory 7-Way		10
		07	GMC Sierra 1500 HD (Classic), w/Factory 7-Way		10
		01-06	GMC Sierra 1500 HD w/Factory 7-Way		10
		99-18	GMC Sierra 1500 w/Factory 7-Way		10
		01-06	GMC Sierra 1500 HD w/Factory 7-Way		10
		99-18	GMC Sierra 1500 w/Factory 7-Way		10
		07	GMC Sierra 2500 HD (Classic), w/Factory 7-Way		10
		11-12	GMC Sierra 2500 HD Denali HD, w/Factory 7-Way		10
		01-19	GMC Sierra 2500 HD w/Factory 7-Way		10
		99-04	GMC Sierra 2500 w/Factory 7-Way		10
		07	GMC Sierra 3500 (Classic), w/Factory 7-Way		10
		07-19	GMC Sierra 3500 HD w/Factory 7-Way		10
		01-06	GMC Sierra 3500 w/Factory 7-Way		10
		01-17	GMC Yukon Denali w/Amber Turn Signals, w/Factory 7-Way		10
		00-17	GMC Yukon w/Amber Turn Signals, w/Factory 7-Way		10
		01-19	GMC Yukon XL 1500 Denali w/Factory 7-Way		10
		00-11	GMC Yukon XL 1500 w/Factory 7-Way		10
		00-13	GMC Yukon XL 2500 w/Factory 7-Way		10
		03-09	Hummer H2 w/Factory 7-Way		10
		06-10	Hummer H3 w/Factory 7-Way		10
		09-10	Hummer H3T w/Factory 7-Way		10
		03-08	Isuzu Ascender w/Factory 7-Way		10
		99-04	Oldsmobile Bravada w/Factory 7-Way		10
		05-09	Saab 9-7X w/Factory 7-Way		10
		07-09	Saturn Outlook w/Factory 7-Way		10
			20K / 22K / 25K FIFTH WHEEL		
	30160	13-19	RAM 2500 w/Factory HD Towing Option	182	
		14-19	RAM 3500 w/Factory HD Towing Option		
			RAILS & BRACKET KITS		
	30035	73-86	Chevrolet C10	54	
		88-99	Chevrolet C1500		
		73-86	Chevrolet C20		
		88-99	Chevrolet C2500		
		73-86	Chevrolet C30		
		88-00	Chevrolet C3500		
		73-86	Chevrolet K10		
		88-99	Chevrolet K1500		

FIFTH WHEEL RAIL KIT INDEX

PC	PART NO.	YEARS	MAKE/MODEL	WGT LBS	IN
	30035	73-86	Chevrolet K20	54	
		88-99	Chevrolet K2500		
		73-86	Chevrolet K30		
		88-00	Chevrolet K3500		
		99-06	Chevrolet Silverado 1500		
		07	Chevrolet Silverado 1500 (Classic)		
		01-06	Chevrolet Silverado 1500 HD		
		07	Chevrolet Silverado 1500 HD (Classic)		
		07-19	Chevrolet Silverado 1500 LD (Old Body Style) Except High Desert Package		
		99-04	Chevrolet Silverado 2500		
		01-14	Chevrolet Silverado 2500 HD		
		07	Chevrolet Silverado 2500 HD (Classic)		
		15-19	Chevrolet Silverado 2500 HD Except with OEM HD Towing Prep Package		
		01-06	Chevrolet Silverado 3500		
		07	Chevrolet Silverado 3500 (Classic)		
		07-14	Chevrolet Silverado 3500 HD		
		15-19	Chevrolet Silverado 3500 HD Except with OEM HD Towing Prep Package		
		73-89	Dodge D100		
		77-93	Dodge D150		
		73-80	Dodge D200		
		81-93	Dodge D250		
		73-80	Dodge D300		
		81-93	Dodge D350		
		94-04	Dodge Dakota		
		94-10	Dodge Ram 1500		
		94-02	Dodge Ram 2500		
		03-10	Dodge Ram 2500 Except w/Overload Springs		
		03-10	Dodge Ram 2500 w/Overload Springs		
		94-02	Dodge Ram 3500		
		03-10	Dodge Ram 3500 Except w/Overload Springs		
		03-10	Dodge Ram 3500 w/Overload Springs		
		75-83	Ford F-100		
		75-14	Ford F-150		
		15-19	Ford F-150 Except Raptor		
		04	Ford F-150 Heritage Styleside		
		97-03	Ford F-150 Styleside, Except SuperCrew		
		75-96	Ford F-250		
		97	Ford F-250 Heavy Duty		
		97-99	Ford F-250 Styleside		
		99-16	Ford F-250 Super Duty Except Cab & Chassis		
		75-96	Ford F-350		
		97	Ford F-350 Heavy Duty		
		99-16	Ford F-350 Super Duty Except Cab & Chassis		
		08-16	Ford F-450 Super Duty Except Cab & Chassis		
		75-78	GMC C15		
		73-74	GMC C15/C1500		
		79-99	GMC C1500		
		75-78	GMC C25		
		67-74	GMC C25/C2500		
		79-00	GMC C2500		
		75-78	GMC C35		
		73-74	GMC C35/C3500		
		79-00	GMC C3500		
		92-00	GMC C3500 Crew Cab		
		73-78	GMC K15		
		79-99	GMC K1500		
		73-78	GMC K25		
		79-00	GMC K2500		
		73-78	GMC K35		
		79-00	GMC K3500		
		92-00	GMC K3500 Crew Cab		
		99-06	GMC Sierra 1500		
		07	GMC Sierra 1500 (Classic)		
		01-06	GMC Sierra 1500 HD		
		07	GMC Sierra 1500 HD (Classic)		
		07-19	GMC Sierra 1500 LD (Old Body Style)		
		99-04	GMC Sierra 2500		
		01-14	GMC Sierra 2500 HD		
		07	GMC Sierra 2500 HD (Classic)		
		15-19	GMC Sierra 2500 HD Except with OEM HD Towing Prep Package		
		01-06	GMC Sierra 3500		
		07	GMC Sierra 3500 (Classic)		
		07-14	GMC Sierra 3500 HD		

PC	PART NO.	YEARS	MAKE/MODEL	WGT LBS	IN
	30035	15-19	GMC Sierra 3500 HD Except with OEM HD Towing Prep Package	54	
		04-15	Nissan Titan		
		11-12	RAM 1500		
		19	RAM 1500 (Classic), Except w/Air Suspension		
		19	RAM 1500 (Classic), Except w/Air Suspension or w/ECODiesel Engine		
		14-18	RAM 1500 Except w/Air Suspension		
		13-18	RAM 1500 Except w/Air Suspension or w/ECODiesel Engine		
		14-19	RAM 2500		
		11-13	RAM 2500 Except w/Overload Springs		
		11-12	RAM 2500 w/Overload Springs		
		13-18	RAM 3500		
		11-12	RAM 3500 Except w/Overload Springs		
		11-12	RAM 3500 w/Overload Springs		
		07-19	Toyota Tundra		
		00-06	Toyota Tundra Regular Cab 8 ft. Bed		
	50026	11-16	Ford F-250 Super Duty Except Cab & Chassis	27	
		11-16	Ford F-350 Super Duty Except Cab & Chassis		
		11-16	Ford F-450 Super Duty Except Cab & Chassis		
	50026-58	11-16	Ford F-250 Super Duty Except Cab & Chassis	70	
		11-16	Ford F-350 Super Duty Except Cab & Chassis		
		11-16	Ford F-450 Super Duty Except Cab & Chassis		
	50040	02-08	Dodge Ram 1500 Except Mega Cab	60	
		03-10	Dodge Ram 2500 Except Mega Cab & w/Overload Springs		
		03-10	Dodge Ram 3500 Except Mega Cab & w/Overload Springs		
		11-12	RAM 2500 Except Mega Cab & w/Overload Springs		
		11-12	RAM 3500 Except Mega Cab & w/Overload Springs		
	50040-58	02-08	Dodge Ram 1500 Except Mega Cab	98	
		03-10	Dodge Ram 2500 Except Mega Cab & w/Overload Springs		
		03-10	Dodge Ram 3500 Except Mega Cab & w/Overload Springs		
		11-12	RAM 2500 Except Mega Cab & w/Overload Springs		
		11-12	RAM 3500 Except Mega Cab & w/Overload Springs		
	50042	04	Ford F-150 Heritage Styleside	28	
		97-03	Ford F-150 Styleside		
		97-99	Ford F-250 Styleside		
	50042-58	04	Ford F-150 Heritage Styleside	66	
		97-03	Ford F-150 Styleside		
		97-99	Ford F-250 Styleside		
	50043	99-04	Ford F-250 Super Duty Except Cab & Chassis	24	
		99-04	Ford F-350 Super Duty Except Cab & Chassis		
	50043-58	99-04	Ford F-250 Super Duty Except Cab & Chassis	64	
		99-04	Ford F-350 Super Duty Except Cab & Chassis		
	50054	14-19	RAM 2500	18	
	50054-58	14-19	RAM 2500	59	
	50064	99-13	Chevrolet Silverado 1500	42	
		07	Chevrolet Silverado 1500 (Classic)		
		01-06	Chevrolet Silverado 1500 HD		
		07	Chevrolet Silverado 1500 HD (Classic)		
		14-19	Chevrolet Silverado 1500 LD (Old Body Style) Does Not Fit MagneRide Magnetic Ride Suspension		
		99-04	Chevrolet Silverado 2500		
		01-10	Chevrolet Silverado 2500 HD		
		07	Chevrolet Silverado 2500 HD (Classic)		
		01-06	Chevrolet Silverado 3500		
		07	Chevrolet Silverado 3500 (Classic)		
		07-10	Chevrolet Silverado 3500 HD		
		99-13	GMC Sierra 1500		
		07	GMC Sierra 1500 (Classic)		
		01-06	GMC Sierra 1500 HD		
		07	GMC Sierra 1500 HD (Classic)		
		14-19	GMC Sierra 1500 LD (Old Body Style) Does Not Fit MagneRide Magnetic Ride Suspension		
		99-04	GMC Sierra 2500		
		01-10	GMC Sierra 2500 HD		
		07	GMC Sierra 2500 HD (Classic)		
		01-06	GMC Sierra 3500		
		07	GMC Sierra 3500 (Classic)		
		07-10	GMC Sierra 3500 HD		
	50064-58	99-13	Chevrolet Silverado 1500	83	
		07	Chevrolet Silverado 1500 (Classic)		
		01-06	Chevrolet Silverado 1500 HD		

FIFTH WHEEL RAIL KIT INDEX

PC	PART NO.	YEARS	MAKE/MODEL	WGT LBS	IN
50064-58	07		Chevrolet Silverado 1500 HD (Classic)	83	
	14-19		Chevrolet Silverado 1500 LD (Old Body Style) Does Not Fit MagneRide Magnetic Ride Suspension		
	99-04		Chevrolet Silverado 2500		
	01-10		Chevrolet Silverado 2500 HD		
	07		Chevrolet Silverado 2500 HD (Classic)		
	01-06		Chevrolet Silverado 3500		
	07		Chevrolet Silverado 3500 (Classic)		
	07-10		Chevrolet Silverado 3500 HD		
	99-13		GMC Sierra 1500		
	07		GMC Sierra 1500 (Classic)		
	01-06		GMC Sierra 1500 HD		
	07		GMC Sierra 1500 HD (Classic)		
	14-19		GMC Sierra 1500 LD (Old Body Style) Does Not Fit MagneRide Magnetic Ride Suspension		
	99-04		GMC Sierra 2500		
	01-10		GMC Sierra 2500 HD		
	07		GMC Sierra 2500 HD (Classic)		
	01-06		GMC Sierra 3500		
07		GMC Sierra 3500 (Classic)			
07-10		GMC Sierra 3500 HD			
50066	11-14		Chevrolet Silverado 2500 HD	31	
	15-19		Chevrolet Silverado 2500 HD Except with OEM HD Towing Prep Package		
	11-14		Chevrolet Silverado 3500 HD		
	15-19		Chevrolet Silverado 3500 HD Except with OEM HD Towing Prep Package		
	11-14		GMC Sierra 2500 HD		
	15-19		GMC Sierra 2500 HD Except with OEM HD Towing Prep Package		
50066-58	11-14		Chevrolet Silverado 2500 HD	76	
	15-19		Chevrolet Silverado 2500 HD Except with OEM HD Towing Prep Package		
	11-14		Chevrolet Silverado 3500 HD		
	15-19		Chevrolet Silverado 3500 HD Except with OEM HD Towing Prep Package		
	11-14		GMC Sierra 2500 HD		
	15-19		GMC Sierra 2500 HD Except with OEM HD Towing Prep Package		
50074	17-19		Ford F-250 Super Duty Except Dual Rear Wheel or Cab & Chassis	28	
	17-19		Ford F-350 Super Duty Except Dual Rear Wheel or Cab & Chassis		
	17-19		Ford F-350 Super Duty Except Dual Rear Wheel or Cab & Chassis		
50074-58	17-19		Ford F-250 Super Duty Except Dual Rear Wheel or Cab & Chassis	89	
	17-19		Ford F-350 Super Duty Except Dual Rear Wheel or Cab & Chassis		
50081	04-14		Ford F-150	24	
50081-58	04-14		Ford F-150	63	
50082	99-10		Ford F-250 Super Duty Except Cab & Chassis	31	
	99-10		Ford F-350 Super Duty Except Cab & Chassis		
	08-10		Ford F-450 Super Duty Except Cab & Chassis		
50082-58	99-10		Ford F-250 Super Duty Except Cab & Chassis	73	
	99-10		Ford F-350 Super Duty Except Cab & Chassis		
	08-10		Ford F-450 Super Duty Except Cab & Chassis		
50084†	07-19		Toyota Tundra	32	
50084-58	07-19		Toyota Tundra	86	
50085	13-18		RAM 3500	30	
50085-58	13-18		RAM 3500	75	
50087	15-19		Ford F-150 Except Raptor	27	
50087-58	15-19		Ford F-150 Except Raptor	68	
50140	06-08		Dodge Ram 1500 Mega Cab	24	
	03-09		Dodge Ram 2500		
	10		Dodge Ram 2500 Except w/Gas Engines w/Overload Springs		
	03-09		Dodge Ram 3500		
	10		Dodge Ram 3500 Except w/Gas Engines w/Overload Springs		
50140-58	11-12		RAM 2500 Except w/Gas Engines w/Overload Springs	65	
	11-12		RAM 3500 Except w/Gas Engines w/Overload Springs		
	06-08		Dodge Ram 1500 Mega Cab		

PC	PART NO.	YEARS	MAKE/MODEL	WGT LBS	IN
50140-58	03-09		Dodge Ram 2500	65	
	10		Dodge Ram 2500 Except w/Gas Engines w/Overload Springs		
	03-09		Dodge Ram 3500		
	10		Dodge Ram 3500 Except w/Gas Engines w/Overload Springs		
	11-12		RAM 2500 Except w/Gas Engines w/Overload Springs		
50141†	19		RAM 1500 (Classic), Except w/Air Suspension or 5.7 ft. Bed	31	
	14-18		RAM 1500 Except w/Air Suspension or 5.7 ft. Bed		
50142	09-10		Dodge Ram 1500	38	
	11-18		RAM 1500		
	19		RAM 1500 (Classic)		
50142-58	09-10		Dodge Ram 1500	74	
	11-18		RAM 1500		
	19		RAM 1500 (Classic)		
56001	11-14		Chevrolet Silverado 2500 HD	22	
	15-19		Chevrolet Silverado 2500 HD Except with OEM HD Towing Prep Package		
	11-14		Chevrolet Silverado 3500 HD		
	15-19		Chevrolet Silverado 3500 HD Except with OEM HD Towing Prep Package		
	11-14		GMC Sierra 2500 HD		
	15-19		GMC Sierra 2500 HD Except with OEM HD Towing Prep Package		
56001-53	11-14		Chevrolet Silverado 2500 HD	70	
	15-19		Chevrolet Silverado 2500 HD Except with OEM HD Towing Prep Package		
	11-14		Chevrolet Silverado 3500 HD		
	15-19		Chevrolet Silverado 3500 HD Except with OEM HD Towing Prep Package		
	11-14		GMC Sierra 2500 HD		
	15-19		GMC Sierra 2500 HD Except with OEM HD Towing Prep Package		
56005	99-10		Ford F-250 Super Duty Except Cab & Chassis	28	
	99-10		Ford F-350 Super Duty Except Cab & Chassis		
	08-10		Ford F-450 Super Duty Except Cab & Chassis		
56005-53	99-10		Ford F-250 Super Duty Except Cab & Chassis	89	
	99-10		Ford F-350 Super Duty Except Cab & Chassis		
	08-10		Ford F-450 Super Duty Except Cab & Chassis		
56006	04-14		Ford F-150	28	
56006-53	04-14		Ford F-150	89	
56007	99-13		Chevrolet Silverado 1500	36	
	07		Chevrolet Silverado 1500 (Classic)		
	01-06		Chevrolet Silverado 1500 HD		
	07		Chevrolet Silverado 1500 HD (Classic)		
	14-19		Chevrolet Silverado 1500 LD (Old Body Style) Does Not Fit MagneRide Magnetic Ride Suspension		
	99-04		Chevrolet Silverado 2500		
	01-10		Chevrolet Silverado 2500 HD		
	07		Chevrolet Silverado 2500 HD (Classic)		
	01-06		Chevrolet Silverado 3500		
	07		Chevrolet Silverado 3500 (Classic)		
	07-10		Chevrolet Silverado 3500 HD		
56007-53	99-13		GMC Sierra 1500	97	
	07		GMC Sierra 1500 (Classic)		
	01-06		GMC Sierra 1500 HD		
	07		GMC Sierra 1500 HD (Classic)		
	14-19		GMC Sierra 1500 LD (Old Body Style) Does Not Fit MagneRide Magnetic Ride Suspension		
	99-04		GMC Sierra 2500		
	01-10		GMC Sierra 2500 HD		
	07		GMC Sierra 2500 HD (Classic)		
	01-06		GMC Sierra 3500		
	07		GMC Sierra 3500 (Classic)		
07-10		GMC Sierra 3500 HD			
56007-53	99-13		Chevrolet Silverado 1500	97	
	07		Chevrolet Silverado 1500 (Classic)		
	01-06		Chevrolet Silverado 1500 HD		
07		Chevrolet Silverado 1500 HD (Classic)			

FIFTH WHEEL RAIL KIT INDEX

PC	PART NO.	YEARS	MAKE/MODEL	WGT LBS	IN
	56007-53	14-19	Chevrolet Silverado 1500 LD (Old Body Style) Does Not Fit MagneRide Magnetic Ride Suspension	97	
		99-04	Chevrolet Silverado 2500		
		01-10	Chevrolet Silverado 2500 HD		
		07	Chevrolet Silverado 2500 HD (Classic)		
		01-06	Chevrolet Silverado 3500		
		07	Chevrolet Silverado 3500 (Classic)		
		07-10	Chevrolet Silverado 3500 HD		
		99-13	GMC Sierra 1500		
		07	GMC Sierra 1500 (Classic)		
		01-06	GMC Sierra 1500 HD		
		07	GMC Sierra 1500 HD (Classic)		
		14-19	GMC Sierra 1500 LD (Old Body Style) Does Not Fit MagneRide Magnetic Ride Suspension		
		99-04	GMC Sierra 2500		
		01-10	GMC Sierra 2500 HD		
		07	GMC Sierra 2500 HD (Classic)		
		01-06	GMC Sierra 3500		
		07	GMC Sierra 3500 (Classic)		
		07-10	GMC Sierra 3500 HD		
	56009	14-19	RAM 2500	20	
	56009-53	14-19	RAM 2500	79	
	56010	13-14	RAM 3500 Except w/RamBox Cargo Management System	40	
		15-18	RAM 3500 Except w/RamBox Cargo Management System or Models w/Air Suspension		
	56010-53	13-14	RAM 3500 Except w/RamBox Cargo Management System	101	
		15-18	RAM 3500 Except w/RamBox Cargo Management System or Models w/Air Suspension		
	56011	03-10	Dodge Ram 2500	48	
		03-10	Dodge Ram 3500		
		11-13	RAM 2500		
		11-12	RAM 3500		
	56011-53	03-10	Dodge Ram 2500	108	
		03-10	Dodge Ram 3500		
		11-13	RAM 2500		
		11-12	RAM 3500		
	56014f	08-10	Chevrolet Silverado 2500 HD 6.6 ft. Bed	35	
		08-10	Chevrolet Silverado 3500 HD 6.6 ft. Bed		
		08-10	GMC Sierra 2500 HD 6.6 ft. Bed		
		08-10	GMC Sierra 3500 HD 6.6 ft. Bed		
	56014-53f	08-10	Chevrolet Silverado 2500 HD	96	
		08-10	Chevrolet Silverado 3500 HD		
		08-10	GMC Sierra 2500 HD		
		08-10	GMC Sierra 3500 HD		
	56015	19	Chevrolet Silverado 1500 New Body Style, Except 8 ft. Bed	30	
		19	GMC Sierra 1500 New Body Style, Except 8 ft. Bed		
	56015-53	19	Chevrolet Silverado 1500 New Body Style, Except 8 ft. Bed	101	
		19	GMC Sierra 1500 New Body Style, Except 8 ft. Bed		
	56016	11-16	Ford F-250 Super Duty Except Cab & Chassis	30	
		11-16	Ford F-350 Super Duty Except Cab & Chassis		
		11-16	Ford F-450 Super Duty Except Cab & Chassis		
	56016-53	11-16	Ford F-250 Super Duty Except Cab & Chassis	294	
		11-16	Ford F-350 Super Duty Except Cab & Chassis		
		11-16	Ford F-450 Super Duty Except Cab & Chassis		
	56017	17-19	Ford F-250 Super Duty Except Cab & Chassis	37	
		17-19	Ford F-350 Super Duty Except Cab & Chassis		
		17-19	Ford F-450 Super Duty Except Cab & Chassis		
	56017-53	17-19	Ford F-250 Super Duty Except Cab & Chassis	96	
		17-19	Ford F-350 Super Duty Except Cab & Chassis		
		17-19	Ford F-450 Super Duty Except Cab & Chassis		
	56018	19	RAM 1500 New Body Style	14	90
	56018-53	19	RAM 1500 New Body Style	75	90
	56021	13-14	RAM 3500 Except w/RamBox Cargo Management System	40	90
		15-19	RAM 3500 Except w/RamBox Cargo Management System or Models w/Air Suspension		90
	56021-53	13-14	RAM 3500 Except w/RamBox Cargo Management System	100	
		15-19	RAM 3500 Except w/RamBox Cargo Management System or Models w/Air Suspension		
	56034	15-19	Ford F-150 Except Raptor	28	
	56034-53	15-19	Ford F-150	78	
	58023	02-08	Dodge Ram 1500	3	
		03-10	Dodge Ram 2500 Except w/Overload Springs		
		03-10	Dodge Ram 3500 Except w/Overload Springs		
		11-12	RAM 2500 Except w/Overload Springs		
		11-12	RAM 3500 Except w/Overload Springs		

PC	PART NO.	YEARS	MAKE/MODEL	WGT LBS	IN
	58166	02-08	Dodge Ram 1500	1	
		03-10	Dodge Ram 2500 Except w/Overload Springs		
		03-10	Dodge Ram 3500 Except w/Overload Springs		
		11-12	RAM 2500 Except w/Overload Springs		
		11-12	RAM 3500 Except w/Overload Springs		
	58186	03-10	Dodge Ram 2500 w/Overload Springs	12	
		03-10	Dodge Ram 3500 w/Overload Springs		
		11-12	RAM 2500 w/Overload Springs		
		11-12	RAM 3500 w/Overload Springs		
	58197	00-06	Toyota Tundra Regular Cab 8 ft. Bed	1	
	58309	07-19	Toyota Tundra	3	
	58386	09-10	Dodge Ram 1500	18	
		11-12	RAM 1500		
		19	RAM 1500 (Classic), Except w/Air Suspension or w/ECODiesel Engine		
		13-18	RAM 1500 Except w/Air Suspension or w/ECODiesel Engine		
	58405	04-15	Nissan Titan	26	
	58425	05-15	Ford F-250 Super Duty Except Cab & Chassis	4	
		05-15	Ford F-350 Super Duty Except Cab & Chassis		
		08-15	Ford F-450 Super Duty Except Cab & Chassis		
	58426	04-14	Ford F-150	16	
	58432	02-08	Dodge Ram 1500 Except Mega Cab	7	
	58433	09-10	Dodge Ram 1500	4	
		11-12	RAM 1500 Except 5.7 ft. Bed		
		13-14	RAM 1500 Except 5.7 ft. Bed and Models w/Air Suspension		
	58520	13-18	RAM 3500	14	
	58522	14-19	RAM 2500	12	
	58523	09-10	Dodge Ram 1500	19	
		11-12	RAM 1500		
		19	RAM 1500 (Classic), Except w/Air Suspension		
		14-18	RAM 1500 Except w/Air Suspension		
		13	RAM 1500 Except w/Air Suspension or w/ECODiesel Engine		
	58531	15-19	Ford F-150 Except Raptor	9	
M SERIES					
	30890	16-19	Chevrolet Silverado 2500 HD w/Factory HD Towing Option	146	
		16-19	Chevrolet Silverado 3500 HD w/Factory HD Towing Option		
		16-19	GMC Sierra 2500 HD w/Factory HD Towing Option		
		16-19	GMC Sierra 3500 HD w/Factory HD Towing Option		
	30895	16-19	Chevrolet Silverado 2500 HD w/Factory HD Towing Option	146	
		16-19	Chevrolet Silverado 3500 HD w/Factory HD Towing Option		
		16-19	GMC Sierra 2500 HD w/Factory HD Towing Option		
		16-19	GMC Sierra 3500 HD w/Factory HD Towing Option		
	30918	14-19	RAM 2500 w/Factory HD Towing Option	186	
		14-19	RAM 3500 w/Factory HD Towing Option		
	30919	14-19	RAM 2500 w/Factory HD Towing Option	203	
		14-19	RAM 3500 w/Factory HD Towing Option		
	30921	11-19	Ford F-250 Super Duty w/Factory HD Towing Option	148	
		11-19	Ford F-350 Super Duty w/Factory HD Towing Option		
	30922	11-19	Ford F-250 Super Duty w/Factory HD Towing Option	148	
		11-19	Ford F-350 Super Duty w/Factory HD Towing Option		
ELITE SERIES RAIL KITS					
	30061	99-06	Chevrolet Silverado 1500 Except 8 ft. Bed	70	150
		07	Chevrolet Silverado 1500 Except 8 ft. Bed (Classic)		150
		01-06	Chevrolet Silverado 1500 HD		150
		07	Chevrolet Silverado 1500 HD (Classic)		150
		99-04	Chevrolet Silverado 2500 Except 8 ft. Bed		150
		01-10	Chevrolet Silverado 2500 HD Except 8 ft. Bed		150
		07-10	Chevrolet Silverado 3500 HD Except 8 ft. Bed		150
		99-06	GMC Sierra 1500 Except 8 ft. Bed		150
		07	GMC Sierra 1500 Except 8 ft. Bed (Classic)		150
		01-06	GMC Sierra 1500 HD		150
		07	GMC Sierra 1500 HD (Classic)		150
		99-04	GMC Sierra 2500 Except 8 ft. Bed		150
		01-10	GMC Sierra 2500 HD Except 8 ft. Bed		150
		07-10	GMC Sierra 3500 HD Except 8 ft. Bed		150
	30064	04-14	Ford F-150	62	120
	30067	02-08	Dodge Ram 1500 Except Mega Cab	63	120
		03-10	Dodge Ram 2500 Except Mega Cab		120
		03-10	Dodge Ram 3500 Except Mega Cab		120

GOOSENECK HITCH INDEX

PC	PART NO.	YEARS	MAKE/MODEL	WGT LBS	IN
	30067	11-12	RAM 2500 Except Mega Cab	63	120
		11-12	RAM 3500 Except Mega Cab		120
	30073	99-10	Ford F-250 Super Duty Except Cab & Chassis	84	120
		99-10	Ford F-350 Super Duty Except Cab & Chassis		120
		08-10	Ford F-450 Super Duty Except Cab & Chassis		120
	30074	02-08	Dodge Ram 1500	85	120
		03-10	Dodge Ram 2500		120
		03-10	Dodge Ram 3500		120
		11-13	RAM 2500		120
		11-12	RAM 3500		120
	30126	11-16	Ford F-250 Super Duty Except Cab & Chassis	105	
		11-16	Ford F-350 Super Duty Except Cab & Chassis		
		11-16	Ford F-450 Super Duty Except Cab & Chassis		
	30852	10	Dodge Ram 2500	113	
		10	Dodge Ram 3500		
		11-12	RAM 2500		
		11-12	RAM 3500		
	30868	11-19	Chevrolet Silverado 2500 HD Except with OEM HD Towing Prep Package	120	
		11-19	Chevrolet Silverado 3500 HD Except with OEM HD Towing Prep Package		
		11-19	GMC Sierra 2500 HD Except with OEM HD Towing Prep Package		
		11-19	GMC Sierra 3500 HD Except with OEM HD Towing Prep Package		
	30886	17-19	Ford F-250 Super Duty Except Cab & Chassis	95	
		17-19	Ford F-350 Super Duty Except Cab & Chassis		
		17-19	Ford F-450 Super Duty Except Cab & Chassis		
ELITE SERIES ACCESS.					
	30154	13-19	RAM 2500 w/Factory HD Towing Option	90	
		13-19	RAM 3500 w/Factory HD Towing Option		
	30156	11-19	Ford F-250 Super Duty w/Hitch Prep Package	54	
		11-19	Ford F-350 Super Duty w/Hitch Prep Package		
ELITE SERIES GOOSENECK					
	30138-26	11-16	Ford F-250 Super Duty Except Cab & Chassis	120	
		11-16	Ford F-350 Super Duty Except Cab & Chassis		
		11-16	Ford F-450 Super Duty Except Cab & Chassis		
	30158-52	10	Dodge Ram 2500	163	
		10	Dodge Ram 3500		
		11-12	RAM 2500		
		11-12	RAM 3500		
	30158-68	11-19	Chevrolet Silverado 2500 HD Except with OEM HD Towing Prep Package	170	
		11-19	Chevrolet Silverado 3500 HD Except with OEM HD Towing Prep Package		
		11-19	GMC Sierra 2500 HD Except with OEM HD Towing Prep Package		
		11-19	GMC Sierra 3500 HD Except with OEM HD Towing Prep Package		
UNDER-BED GOOSENECK					
	4494	17-19	Ford F-250 Super Duty Except Cab & Chassis	110	120
		17-19	Ford F-350 Super Duty Except Cab & Chassis		120
		17-19	Ford F-450 Super Duty Except Cab & Chassis		120
	9460-39	94-01	Dodge Ram 1500	91	90
		94-02	Dodge Ram 2500		90
		94-02	Dodge Ram 3500		90
	9460-48†	99-16	Ford F-250 Super Duty Except Cab & Chassis	95	90
		99-16	Ford F-350 Super Duty Except Cab & Chassis		90
	9460-49	99-16	Ford F-250 Super Duty Except Cab & Chassis	102	90
		99-16	Ford F-350 Super Duty Except Cab & Chassis		90
		08-16	Ford F-450 Super Duty Except Cab & Chassis		90
	9464-35	06-08	Dodge Ram 1500 Mega Cab	114	90
		03-10	Dodge Ram 2500		90
		03-10	Dodge Ram 3500		90
		11-12	RAM 2500		90
		11-12	RAM 3500		90
	9464-38	02-08	Dodge Ram 1500 Except Mega Cab	110	90
	9464-46	09-10	Dodge Ram 1500	121	90
		19	RAM 1500 (Classic), Except w/Air Suspension		90
		11-18	RAM 1500 Except w/Air Suspension		90
	9464-57	10	Dodge Ram 2500	124	110
		10	Dodge Ram 3500		110
		11-13	RAM 2500		125
		11-12	RAM 3500		110
	9465-34	99-04	Chevrolet Silverado 2500	93	105
		01-10	Chevrolet Silverado 2500 HD		105
		07-10	Chevrolet Silverado 3500 HD		105

PC	PART NO.	YEARS	MAKE/MODEL	WGT LBS	IN
	9465-34	99-04	GMC Sierra 2500	93	105
		01-10	GMC Sierra 2500 HD		105
		07-10	GMC Sierra 3500 HD		105
	9465-36	07-19	Toyota Tundra	94	90
	9465-37	04-14	Ford F-150	91	90
	9465-40	88-99	Chevrolet C1500	101	105
		88-99	Chevrolet C2500		105
		88-00	Chevrolet C3500 Except Crew Cab		105
		88-99	Chevrolet K1500		105
		88-99	Chevrolet K2500		105
		88-00	Chevrolet K3500 Except Crew Cab		105
		88-99	GMC C1500		105
		88-99	GMC C2500		105
		88-00	GMC C3500 Except Crew Cab		105
		88-99	GMC K1500		105
		88-99	GMC K2500		105
		88-00	GMC K3500 Except Crew Cab		105
	9465-45	01-07	Chevrolet Silverado 3500 8 ft. Bed	106	90
		01-07	GMC Sierra 3500 8 ft. Bed		90
	9465-54	99-13	Chevrolet Silverado 1500	96	105
		07	Chevrolet Silverado 1500 (Classic)		105
		01-06	Chevrolet Silverado 1500 HD		105
		07	Chevrolet Silverado 1500 HD (Classic)		105
		14-19	Chevrolet Silverado 1500 LD (Old Body Style) Does Not Fit MagneRide Magnetic Ride Suspension		105
		99-04	Chevrolet Silverado 2500 6.6 ft. Bed		105
		99-13	GMC Sierra 1500		105
		07	GMC Sierra 1500 (Classic)		105
		01-07	GMC Sierra 1500 HD		105
		14-19	GMC Sierra 1500 LD (Old Body Style) Does Not Fit MagneRide Magnetic Ride Suspension		105
		99-04	GMC Sierra 2500 6.6 ft. Bed		105
	9465-56	11-19	Chevrolet Silverado 2500 HD Except with OEM HD Towing Prep Package	97	45
		11-19	Chevrolet Silverado 3500 HD Except with OEM HD Towing Prep Package		45
		11-19	GMC Sierra 2500 HD Except with OEM HD Towing Prep Package		45
		11-19	GMC Sierra 3500 HD Except with OEM HD Towing Prep Package		45
	9465-91	15-19	Ford F-150 Except Raptor	88	90
	9466	13-18	RAM 3500 (Gooseneck Head Does Not Require Rail Kit)	52	60
	9467	14-18	RAM 2500 (Gooseneck Head Does Not Require Rail Kit)	49	30
	9468-94	17-19	Ford F-250 Super Duty Except Cab & Chassis	169	120
		17-19	Ford F-350 Super Duty Except Cab & Chassis		120
		17-19	Ford F-450 Super Duty Except Cab & Chassis		120
	9476†	13-15	RAM 3500 (Gooseneck Head Does Not Require Rail Kit)	52	60
	9477†	14-15	RAM 2500 (Gooseneck Head Does Not Require Rail Kit)	49	30
ABOVE-BED GOOSENECK					
	4434	99-02	Chevrolet Silverado 2500	59	105
		01-10	Chevrolet Silverado 2500 HD		105
		07-10	Chevrolet Silverado 3500 HD		105
		99-04	GMC Sierra 2500		105
		01-10	GMC Sierra 2500 HD		105
		07-10	GMC Sierra 3500 HD		105
	4435	06-08	Dodge Ram 1500 Mega Cab	71	90
		03-10	Dodge Ram 2500		90
		03-10	Dodge Ram 3500		90
		11-12	RAM 2500		90
		11-12	RAM 3500		90
	4436	07-19	Toyota Tundra	57	90
	4437	04-14	Ford F-150	55	90
	4438	02-08	Dodge Ram 1500 Except Mega Cab	66	90
	4439	94-01	Dodge Ram 1500	48	90
		94-02	Dodge Ram 2500		90
		94-02	Dodge Ram 3500		90
	4440	88-99	Chevrolet C1500	65	105
		88-99	Chevrolet C2500		105
		88-00	Chevrolet C3500 Except Crew Cab		105
		88-99	Chevrolet K1500		105
		88-99	Chevrolet K2500		105
		88-00	Chevrolet K3500 Except Crew Cab		105
		88-99	GMC C1500		105

TRUCK BED RACK INDEX

PC	PART NO.	YEARS	MAKE/MODEL	WGT LBS	IN
	4440	88-99 88-00 88-99 88-99 88-00	GMC C2500 GMC C3500 Except Crew Cab GMC K1500 GMC K2500 GMC K3500 Except Crew Cab	65	105 105 105 105 105
	4445	01-06 07 01-06 07	Chevrolet Silverado 3500 8 ft. Bed Chevrolet Silverado 3500 8 ft. Bed (Classic) GMC Sierra 3500 8 ft. Bed GMC Sierra 3500 8 ft. Bed (Classic)	61	90 90 90 90
	4446	09-10 11-19	Dodge Ram 1500 RAM 1500 (Classic) Except w/Air Suspension	82	90 90
	44481	99-16 99-16	Ford F-250 Super Duty Except Cab & Chassis Ford F-350 Super Duty Except Cab and Chassis	68	90 90
	4449	99-16 99-16 08-16	Ford F-250 Super Duty Except Cab & Chassis Ford F-350 Super Duty Except Cab & Chassis Ford F-450 Super Duty Except Cab & Chassis	78	90 90 90
	4454	99-13 07 14-19 01-06 07 99-04 99-13 07 01-06 07 14-19 99-04	Chevrolet Silverado 1500 Chevrolet Silverado 1500 (Classic) Chevrolet Silverado 1500 Does Not Fit MagneRide Magnetic Ride Suspension Chevrolet Silverado 1500 HD Chevrolet Silverado 1500 HD (Classic) Chevrolet Silverado 2500 6.6 ft. Bed GMC Sierra 1500 GMC Sierra 1500 (Classic) GMC Sierra 1500 HD GMC Sierra 1500 HD (Classic) GMC Sierra 1500 LD (Old Body Style) Does Not Fit MagneRide Magnetic Ride Suspension GMC Sierra 2500 6.6 ft. Bed	57	105 105 105 105 105 105 105 105 105 105 105 105
	4456	11-19 11-19 11-19 11-19	Chevrolet Silverado 2500 HD Except with OEM HD Towing Prep Package Chevrolet Silverado 3500 HD Except with OEM HD Towing Prep Package GMC Sierra 2500 HD Except with OEM HD Towing Prep Package GMC Sierra 3500 HD Except with OEM HD Towing Prep Package	58	45 45 45 45
	4457	10	Dodge Ram 2500	84	110
		11-18 11-13 14-17 16-17	Honda Odyssey w/Factory Roof Rails Infiniti QX56 w/Factory Roof Rails Infiniti QX80 w/Factory Roof Rails Mercedes-Benz Metris w/Factory Roof Rails		10 10 10 10
TRUCK BED RACKS					
	59742	04-16 94-04 07-18 99-07 01-07 99-04 07-18 01-07 01-07 07-18 97-10 94-10 94-10 94-10 04-18 01-11 04-12 07-18 99-07 01-07 99-04 07-18 01-07 01-07 07-18 94-04 11-17 11-17 11-17 11 00-17	Chevrolet Colorado Chevrolet S10 Chevrolet Silverado 1500 Chevrolet Silverado 1500 (Classic) Chevrolet Silverado 1500 HD (Classic) Chevrolet Silverado 2500 Chevrolet Silverado 2500 HD Chevrolet Silverado 2500 HD (Classic) Chevrolet Silverado 3500 (Classic) Chevrolet Silverado 3500 HD Dodge Dakota Dodge Ram 1500 Dodge Ram 2500 Dodge Ram 3500 Ford F-150 Except Flareside Ford Ranger GMC Canyon GMC Sierra 1500 GMC Sierra 1500 (Classic) GMC Sierra 1500 HD (Classic) GMC Sierra 2500 GMC Sierra 2500 HD GMC Sierra 2500 HD (Classic) GMC Sierra 3500 (Classic) GMC Sierra 3500 HD GMC Sonoma RAM 1500 Except w/RamBox Cargo Management System RAM 2500 Except w/RamBox Cargo Management System RAM 3500 Except w/RamBox Cargo Management System RAM Dakota Toyota Tundra Except w/Integrated Deck Rail Systems	59	40 40
	59799	04-15	Nissan Titan w/Factory Bed Channel System (Deck Rail System)	44	40

INDEX

PART NO.	DESCRIPTION	PAGE NUMBER
001501	Wheel Bearing Grease Cap	N-10
001503	Wheel Bearing Grease Cap	N-10
001505	Wheel Bearing Grease Cap	N-10
001515	Wheel Bearing Grease Cap	N-10
001520	Wheel Bearing Grease Cap	N-10
001521	Wheel Bearing Grease Cap	N-10
001523	Wheel Bearing Grease Cap	N-10
001524	Wheel Bearing Grease Cap	N-10
001526	Wheel Bearing Grease Cap	N-10
001531	Wheel Bearing Grease Cap	N-10
001601	Wheel Bearing Grease Cap	N-10
001602	Wheel Bearing Grease Cap	N-10
001604	Wheel Bearing Grease Cap	N-10
001605	Wheel Bearing Grease Cap	N-10
001607	Wheel Bearing Grease Cap	N-10
001609	Wheel Bearing Grease Cap	N-10
002215	4-Flat Connector Harness - Trailer End	C-12
002220	4-Flat Connector Harness - Trailer End	C-12, M-18, M-23
002230	4-Flat Connector Harness - Trailer End	C-12
002235	4-Flat Connector Harness - Trailer End	C-12
002240	4-Flat Connector Harness - Trailer End	C-12
002275	5-Flat Connector Harness - Trailer End	C-15
002280	5-Flat Connector Harness - Trailer End	C-15
002285	5-Flat Connector Harness - Trailer End	C-15
002290	5-Flat Connector Harness - Trailer End	C-15
002301	4-Flat Connector Harness - Vehicle End	C-12, M-8, M-9, M-18, M-20, M-23
002309	5-Flat Connector Harness - Car End	C-15
002401	4-Flat Connector Harness - Trailer End	C-12
002402	4-Flat Connector Harness - Trailer End	C-12
002408	Ag Extension Harnesses	C-25
002409	5-Flat Connector Harness - Trailer End	C-15
002410	Ag Extension Harnesses	C-25
002415	Ag Extension Harnesses	C-25
002425	Ag Extension Harnesses	C-25
002430	Ag Extension Harnesses	C-25
002435	Ag Extension Harnesses	C-25
002478	7-Way Connector Harness - Trailer End	C-18
002500	Tandem Haul Adapters	C-24
002504	Ag Extension Harnesses	C-25
002505	Ag Extension Harnesses	C-25
002510	Ag Extension Harnesses	C-25
002515	Ag Extension Harnesses	C-25
002590	Replacement Part	M-48, M-49
002625	Tandem Haul Adapters	C-24
002670	Economy Ag Light Kit	M-48
002675	Ag Transport Light Kits	M-49
002676	Ag Transport Light Kits	M-49
002802	Chassis Clip	C-32
002805	Wire Nuts	C-32
002806	Wire Taps	C-32
002807	Wire Taps	C-32
003101	Clearance Lights w/ Reflex Lens	M-20, M-35
003103	Clearance Lights w/ Reflex Lens	M-35
003121	Clearance Lights w/ Reflex Lens	M-35
003123	Clearance Lights w/ Reflex Lens	M-35
0031350300	Bottom Support Plates	J-14, J-32
0031550300	Tube Mounts	J-14, J-31
003201	License Plate Brackets	M-8, M-9, M-18, M-20, M-23, M-42
003202	License Plate Brackets	M-42
003211	License Plate Brackets	M-8, M-9, M-18, M-20, M-23, M-42
003213	License Plate Brackets	M-42
003225	Clearance / Side Marker Lights	M-37
003230	Waterproof Clearance Lights	M-32
003231	Waterproof Clearance Lights	M-32
003232	Waterproof Courtesy Lights	M-23
003238	Waterproof Clearance Lights	M-32
003239	Waterproof Clearance Lights	M-32
003272	Waterproof Clearance Lights	M-32

PART NO.	DESCRIPTION	PAGE NUMBER
003273	Waterproof Clearance Lights	M-32
003305	Waterproof ID Light Bars	M-40
003306	Waterproof ID Light Bars	M-40
003327	Replacement Part - Side Marker Lens	M-35
003328	Replacement Part - Side Marker Lens	M-23, M-35
003330	Replacement Part - Side Marker Lens	M-37
003337	Replacement Part - Trailer Light Lens	M-35
003338	Replacement Part - Trailer Light Lens	M-23, M-35
003340	Replacement Part - Trailer Light Lens	M-37
003357	Rectangular Trailer Reflector	M-42
003358	Rectangular Trailer Reflector	M-42
003387	Rectangular Trailer Reflector	M-43
003388	Rectangular Trailer Reflector	M-43
003440	Dual Bulb Clearance / Side Marker Lights	M-36
003441	Dual Bulb Clearance / Side Marker Lights	M-36
0050050300	Tube Mounts	J-14, J-31
0050240300	Tube Mounts	J-14, J-14, J-31
005122	Tube Mounts	J-14, J-31
006504	Waterproof Trailer Taillights	M-20
006554	Waterproof Trailer Taillights	M-20
007257	Trailer Connector Adapter - 7 to 5-Flat	C-26
007509	Waterproof Trailer Taillights	M-20
007539	Waterproof Trailer Taillights	M-20
008540	Trailer Fender	N-11
008541	Trailer Fender	N-11
008542	Trailer Fender	N-11
008543	Trailer Fender	N-11
008549	Trailer Fender	N-11
008550	Trailer Fender	N-11
008551	Trailer Fender	N-11
008553	Trailer Fender	N-11
008554	Trailer Fender	N-11
008559	Trailer Fender	N-11
008561	Trailer Fender	N-11
008563	Trailer Fender	N-11
008564	Trailer Fender	N-11
008572	Trailer Fender	N-11
008573	Trailer Fender	N-11
008574	Trailer Fender	N-11
008575	Trailer Fender	N-11
008582	Trailer Fender	N-11
008583	Trailer Fender	N-11
008584	Trailer Fender	N-11
008585	Trailer Fender	N-11
008592	Trailer Fender	N-11
008593	Trailer Fender	N-11
008594	Trailer Fender	N-11
008595	Trailer Fender	N-11
0133310S00	Replacement Part - Trailer Winch	L-4
0133311S00	Replacement Part - Trailer Winch	L-4
0133312S00	Replacement Part - Trailer Winch	L-4
0133313S00	Replacement Part - Trailer Winch	L-4
015181	Sidewind Crank Assembly	J-20, J-34
0152710300	Tube Mounts	J-14, J-31
0152730300	Tube Mounts	J-14, J-31
0152790300	Tube Mounts	J-14, J-31
017125	Steel Wheels	J-14
0180060301	Trailer Jack	J-29
0180070301†	Trailer Jack	J-37
0180340301†	Trailer Jack	J-37
018098	Trailer Jack Foot	J-14, J-31
0181550317	Trailer Jack Gearbox	J-29
0181590317†	Trailer Jack Gearbox	J-37
0181610317	Trailer Jack Gearbox	J-29
0181620317†	Trailer Jack Gearbox	J-37
0181640317†	Trailer Jack Gearbox	J-37
0181670317†	Trailer Jack Gearbox	J-37
0181710317†	Trailer Jack Gearbox	J-37
0181730324	Trailer Jack Foot Plate	J-31
0181770317†	Trailer Jack Gearbox	J-37
0181890378†	Trailer Jack Gearbox	J-37

PRODUCT INDEX

PART NO.	DESCRIPTION	PAGE NUMBER
0181910378†	Trailer Jack Gearbox	J-29, J-37
0183080301†	Trailer Jack Wheel	J-29, J-37
0185100301	Trailer Jack	J-29
0185200301	Trailer Jack	J-29
0185400301†	Trailer Jack	J-37
0185640301	Removable Disc Feet	J-31
0190600324†	Trailer Jack Wheel	J-29, J-37
0191410310	Trailer Jack Gearbox	J-29
01932-003	Drill Bit	A-9
01933-003	Drill Bit	A-9
01934-003	Drill Bit	A-9
01938-003	Drill Bit	A-9
0233010300	Gooseneck Coupler Adjustable Tube	K-5
0233060301	Replacement Part - Pin Kit	K-3
0233100300	Replacement Part - Coupler Repair Kit	K-5
0233120300	Gooseneck Trailer Coupler Outer Tube	K-4
024200	Replacement Part - Coupler Repair Kit	K-8
024202	Replacement Part - Coupler Hardware Kit	K-7, K-12
0252010201	Trailer Hitch Safety Chain	J-32
028242	Round Tubular Mount Trailer Coupler	K-9
028243	Square/Rectangular Mount Trailer Coupler	K-9
028244	Square/Rectangular Mount Trailer Coupler	K-9
028287	A-Frame Trailer Coupler	K-10
028288	A-Frame Trailer Coupler	K-10
028351†	Class III Trailer Hitch Ball	B-25
028352†	Class III Trailer Hitch Ball	B-25
028375†	Class III Trailer Hitch Ball	B-25
028381	Round Tubular Mount Trailer Coupler	K-9
028382	Square/Rectangular Mount Trailer Coupler	K-9
028383	Round Tubular Mount Trailer Coupler	K-9
028384	A-Frame Trailer Coupler	K-10
028386	A-Frame Trailer Coupler	K-10
028387	Square/Rectangular Mount Trailer Coupler	K-9
028390	Adjustable Channel Mount Trailer Coupler	K-10
028400†	Class III Trailer Hitch Ball	B-25
028442	Round Tubular Mount Trailer Coupler	K-9
028444	Square/Rectangular Mount Trailer Coupler	K-9
028461	Round Tubular Mount Trailer Coupler	K-9
028462	Square/Rectangular Mount Trailer Coupler	K-9
028463	A-Frame Trailer Coupler	K-10
028499	A-Frame Trailer Coupler	K-10
028584	Rigid Mount Adjustable Trailer Coupler	K-10
028585	Rigid Mount Adjustable Trailer Coupler	K-10
028630	Adjustable Channel Mount Trailer Coupler	K-10
028655	A-Frame Trailer Coupler	K-10
028656	A-Frame Trailer Coupler	K-10
028657	Adjustable Channel Mount Trailer Coupler	K-10
0287600300	Gooseneck Trailer Coupler	K-5
0287610300	Gooseneck Trailer Coupler	K-5
0287620300	Gooseneck Trailer Coupler	K-5
0287650300	Gooseneck Trailer Coupler	K-5
0287690300	Gooseneck Trailer Coupler	K-5
0287740300	Gooseneck Trailer Coupler	K-5
0287760300	Gooseneck Trailer Coupler	K-5
0287790300	Gooseneck Trailer Coupler	K-6
0287800300	Gooseneck Trailer Coupler	K-6
0287820300	Gooseneck Trailer Coupler	K-6
0288660300	Gooseneck Trailer Coupler	K-6
028900	Gooseneck Trailer Coupler	K-6
0289250300	Gooseneck Trailer Coupler	K-5
0289340317	Gooseneck Trailer Coupler	K-5
0289500300	Gooseneck Trailer Coupler	K-5
0289580300	Gooseneck Trailer Coupler	K-7
0289590300	Gooseneck Trailer Coupler	K-7
0289600300	Gooseneck Trailer Coupler	K-6
0289640300	Gooseneck Trailer Coupler	K-7
0289650300	Gooseneck Trailer Coupler	K-7
0289800300	Gooseneck Trailer Coupler	K-6
0289SB0140	Replacement Part - Bolt Kit	K-7
05330-010†	Trailer Hitch Tube Cover	B-29
06237	Trailer Hitch Pin	B-20

PART NO.	DESCRIPTION	PAGE NUMBER
07010-024†	Trailer Hitch Tube Cover	B-29
0933301S00	Replacement Part	J-10
0933302S00	Replacement Part	J-10
0933305S00	Replacement Part	J-10
0933306S00	Replacement Part	J-6, J-10
0933307S00	Replacement Part	J-10
0933323S00	Replacement Part	J-10
0933325S00	Replacement Part	J-10
1000750†	Water Wick	N-17
100235	Wheel Bearing Grease Cap	N-10
101469	4-Flat Connector Harness - Vehicle End	C-12
1024	Breakaway Charger	N-5
1026	Breakaway System	N-3
1028	Breakaway System	N-3
1040900†	Roof Top Cargo Carrier	I-16
1041000	Roof Top Cargo Carrier	I-4
1041100	Cargo Carrier Bag	I-4
1041500	Trailer Hitch Cargo Carrier	I-6
1043000	Rainproof Cargo Carrier Bag	I-6
104393	4-Flat Dust Cover	C-14
104429	Chassis Clip	C-32
105	Combo Lock Set	C-7
105728	Agriculture Light Plug Holder	C-25
106289	Replacement Part	M-27, M-31
106293	Replacement Part	M-27, M-31
106310	Replacement Part - Lights	M-40
106334	Replacement Part - Lights	M-31
106410	Agriculture Light	M-20
106411	Agriculture Light	M-20
106873	Replacement Part	M-10, M-11, M-21, M-24, M-37
108119	Trailer Light Mounting Bracket	M-10, M-11, M-21, M-24, M-37
108297	Replacement Part	M-27, M-31
108318	Ag Light Enhanced Lighting Modules	C-25
108663	Replacement Part	M-26, M-27, M-30, M-31, M-40
108820	4-Flat Connector Harness - Trailer End	C-12
108825	4-Flat Connector Harness - Trailer End	C-12, M-8, M-9, M-20
108830	4-Flat Connector Harness - Trailer End	C-12
108835	4-Flat Connector Harness - Trailer End	C-12
108840	4-Flat Connector Harness - Trailer End	C-12
108891	Replacement Bulbs	M-17, M-18, M-19, M-20, M-21, M-23, M-35, M-36, M-36, M-45
11003	Trailer Hitch Extension	B-16
11004	Trailer Hitch Extension	B-16
11006	Trailer Hitch Extension	B-16
11029	Trailer Hitch Receiver Tube	A-9
11081	Trailer Hitch Receiver Tube	A-9
111428	Replacement Part - Fifth Wheel	F-13, F-14
11200 0101	Straight Trailer Coupler	K-11
1124	Hole Saw	A-9
11250 0101	Straight Trailer Coupler	K-11
11300 0101	Straight Trailer Coupler	K-11
117300	Replacement Part - Fifth Wheel	F-3, F-5, F-13, F-14, F-15, G-4
117398	Point of Purchase Display	O-4
117400	RV Trailer Jack End Caps	O-4
11755	Electrical Contact Grease	C-31
118001	4-Flat Connector Harness - Vehicle End	C-13
118001-024	4-Flat Connector Harness - Vehicle End	C-13
118001-200	4-Flat Connector Harness - Vehicle End	C-13
118002	4-Flat Connector Harness - Vehicle End	C-13
118002-024	4-Flat Connector Harness - Vehicle End	C-13
118002-200	4-Flat Connector Harness - Vehicle End	C-13
118004	4-Flat Connector Harness - Trailer End	C-13
118004-012	4-Flat Connector Harness - Trailer End	C-13
118009	4-Flat Connector Harness - Trailer End	C-13
118016	5-Flat Connector Harness - Vehicle End	C-15

PART NO.	DESCRIPTION	PAGE NUMBER
118016-025	5-Flat Connector Harness - Vehicle End	C-15
118017	5-Flat Connector Harness - Trailer End	C-15
118019	Trailer Connector Adapter - 7 to 12v	C-27
118020†	7-Way Connector - Vehicle End	C-34
118020-006	7-Way Connector - Vehicle End	C-17
118020-050	7-Way Connector - Vehicle End	C-17
118021	7-Way Connector - Trailer End	C-17
118021-006	7-Way Connector - Trailer End	C-17
118021-050	7-Way Connector - Trailer End	C-17
118030	7-Way Connector - Vehicle End	C-17
118031	7-Way Connector - Trailer End	C-17
118033	4-Flat Connector Harness - Trailer End	C-13
118033-012	4-Flat Connector Harness - Trailer End	C-13
118036	6-Way Connector - Vehicle End	C-16
118036-006	6-Way Connector - Vehicle End	C-16
118036-050	6-Way Connector - Vehicle End	C-16
118037	6-Way Connector - Trailer End	C-16
118037-006	6-Way Connector - Trailer End	C-16
118037-050	6-Way Connector - Trailer End	C-16
118043	4-Flat Connector Harness - Vehicle End	C-14
118044	4-Flat Connector Harness - Loop	C-13
118044-010	4-Flat Connector Harness - Loop	C-13
118044-175	4-Flat Connector Harness - Loop	C-13
118045	4-Flat Connector Harness - Loop	C-13
118045-010	4-Flat Connector Harness - Loop	C-13
118045-175	4-Flat Connector Harness - Loop	C-13
118077	4-Way Round Connectors - Car and Trailer	C-13
118101	4-Way Round Connector - Vehicle End	C-13
118102	4-Way Round Connector - Trailer End	C-13
118104	Trailer Connector Adapter - 4 to 6-Sq	C-16
118132	Towing Electrical Mount Bracket	C-28
118136	Towing Electrical Mount Bracket (1 of 2)	C-29
118137	Towing Electrical Mount Bracket (2 of 2)	C-29
118137-010	Towing Electrical Mount Bracket (2 of 2)	C-29
118138	Towing Electrical Mount Bracket (2 of 2)	C-29
118138-010	Towing Electrical Mount Bracket (2 of 2)	C-29
118140	Towing Electrical Mount Bracket (1 of 2)	C-29
118144	Towing Electrical Mount Bracket (2 of 2)	C-29
118144-010	Towing Electrical Mount Bracket (2 of 2)	C-29
118149	Towing Electrical Mount Bracket	C-28
118149-010	Towing Electrical Mount Bracket	C-28
118150	Trailer Light Power Module Wiring Kit	C-10
118151	Trailer Light Power Module Wiring Kit	C-10
118156	Towing Electrical Box	C-30
118156-010	Towing Electrical Box	C-30
118157	Towing Electrical Box	C-30
118157-010	Towing Electrical Box	C-30
118158	Taillight Converter	C-11
118159	Towing Electrical Box	C-30
118159-010	Towing Electrical Box	C-30
118172-024	4-Flat Connector Harness - Vehicle End	C-13
118172-150	4-Flat Connector Harness - Vehicle End	C-13
118185	4-Flat Connector Harness - Loop	C-13
118185-025	4-Flat Connector Harness - Loop	C-13
118192	4-Flat Connector Harness - Trailer End	C-13
118215	5-Flat Connector Harness - Loop	C-15
118601	Trailer Connector Adapter - 4 to 4-Flat	C-26
118603	4-Way Round Connector - Vehicle End	C-14
118607	Brake Control Wiring Kit	C-23, D-6
118636	4-Flat Connector Harness - Loop	C-13
118664	7-Way Connector - Cable Extension	C-20
118665	Battery Isolation Solenoid	C-31
118666	6-Way Connector - Cable Extension	C-20
118700	Trailer Connector Adapter - 6 to 4-Flat	C-26
118700-050	Trailer Connector Adapter - 6 to 4-Flat	C-26
118702†	Trailer Connector Adapter - 7 to 4-Flat	C-34
118702-050	Trailer Connector Adapter - 7 to 4-Flat	C-26
118703	Trailer Connector Adapter - 7 to 5-Flat	C-26
118704†	Trailer Connector Adapter - 7 to 6-Way	C-34
118704-050	Trailer Connector Adapter - 7 to 6-Way	C-26
118708†	Trailer Connector Adapter - 7 to 6-Way	C-34

PART NO.	DESCRIPTION	PAGE NUMBER
118708-050	Trailer Connector Adapter - 7 to 6-Way	C-26
118709	Trailer Connector Adapter - 7 to 4-Flat	C-26
118710	Trailer Connector Adapter - 7 to 4-Flat	C-26
118799	Brake Control Wiring Kit	C-23
118821	Taillight Isolating System	C-11
119130	Taillight Converter	C-11
119130-012	Taillight Converter	C-11
119130-050	Taillight Converter	C-11
119147	Trailer Light Power Module	C-9
119147-012	Trailer Light Power Module	C-9
119147-050	Trailer Light Power Module	C-9
119148	Trailer Light Power Module	C-9
119177	Trailer Light Power Module	C-9
119178	Taillight Converter	C-11
119178-012	Taillight Converter	C-11
119178-050	Taillight Converter	C-11
119190	Trailer Light Power Module	C-8
119190-012	Trailer Light Power Module	C-8
119190-050	Trailer Light Power Module	C-8
119191	Trailer Light Power Module	C-8
119192	Trailer Light Power Module	C-10
119250	Zero Contact Universal ModuLite	C-8
119251	Zero Contact Universal ModuLite	C-8
1202	Trailer Hitch Tube Cover	B-24
1289000300	Gooseneck Trailer Coupler	K-3
1289020300	Gooseneck Trailer Coupler	K-3
1289030300	Gooseneck Trailer Coupler	K-3
1289040300	Gooseneck Trailer Coupler	K-3
1289050300	Gooseneck Trailer Coupler	K-3
1289070300	Gooseneck Trailer Coupler	K-3
1289080300	Gooseneck Trailer Coupler	K-3
1289130300	Gooseneck Trailer Coupler	K-4
1289140300	Gooseneck Trailer Coupler	K-4
1289170300	Gooseneck Trailer Coupler	K-3
1289200300	Gooseneck Trailer Coupler	K-4
1289210300	Gooseneck Trailer Coupler	K-4
1291020340	Lunette Ring	K-7
1291020383	Lunette Ring	K-7
1390100	Cargo Carrier Bag	I-4
1390600†	Ratcheting Cargo Bar	I-16
1391300	Roof Top Cargo Carrier	I-4
1391800	Cargo Carrier Bag	I-4
13937DT	Bungee Cargo Net	I-12
1394400	Cargo Carrier - Roof Rack	I-4
1394500	Trailer Hitch Cargo Carrier	I-6
1394900	Kayak Carrier - Roof Rack	I-9
1395800	Trailer Hitch Cargo Carrier	I-6
1400300303	Pro Series Bolt-On Jack	J-27
1400400303	Trailer Weld-On Jack - 2,000 lbs	J-27
1400600303	Trailer A-Frame Jack - 5,000 lbs	J-27, O-4
1400700340	Trailer Jack Plate	J-10, J-14
1400750340	Trailer Jack Caster	J-10, J-14
1400800383	Square Trailer Trailer Jack - 8,000 lbs	J-28
1400830383†	Square Trailer Trailer Jack - 8,000 lbs	J-36
1400850383	Square Trailer Trailer Jack - 8,000 lbs	J-28
1400860383	Weld-On Square Trailer Jack - 8,000 lbs	J-28
1400920383	Trailer Jack Handle	J-28
140094	Weld-On Square Trailer Jack - 12,000 lbs	J-28
1400950376	Weld-On Square Trailer Jack - 12,000 lbs	J-28
1400960376	Weld-On Square Trailer Jack - 12,000 lbs	J-28
1400980376	Weld-On Square Trailer Jack - 12,000 lbs	J-28
1400990376	Weld-On Square Trailer Jack - 12,000 lbs	J-28
1401000303	Trailer A-Frame Jack - 2,000 lbs	J-27
1401010376	Weld-On Square Trailer Jack - 12,000 lbs	J-28
1401020303	Trailer Weld-On Jack - 2,000 lbs	J-27
1401030303	Trailer Weld-On Jack - 2,000 lbs	J-27
1401040303	Trailer Weld-On Jack - 2,000 lbs	J-27
1401060303	Trailer Weld-On Jack - 2,000 lbs	J-27
1401080303	Trailer Weld-On Jack - 2,000 lbs	J-27
1401140303	Trailer Weld-On Jack - 2,000 lbs	J-27
1401200303	Trailer Weld-On Jack - 2,000 lbs	J-27

PRODUCT INDEX

PART NO.	DESCRIPTION	PAGE NUMBER
1401420303	Trailer Weld-On Jack - 5,000 lbs	J-27
1401440303	Trailer Weld-On Jack - 5,000 lbs	J-27
1401460303	Trailer Weld-On Jack - 5,000 lbs	J-27
1401480303	Trailer Weld-On Jack - 5,000 lbs	J-27
1401500383†	Square Tube Trailer Jack - 5,000 lbs	J-36
1401520383†	Square Tube Trailer Jack - 5,000 lbs	J-36
1401600383	Square Tube Trailer Jack - 5,000 lbs	J-28
1401610383†	Square Tube Trailer Jack - 5,000 lbs	J-36
1410050149	Marine and Recreational Jacks	J-9
141133	Marine and Recreational Jacks	J-6
1413020134	F2 Jacks - Twin & Wide Track	J-8
1413040134	F2 Jacks - Twin & Wide Track	J-8
1413120334	F2 Jacks - Twin & Wide Track	J-8
1413140334	F2 Jacks - Twin & Wide Track	J-8
1413230134	F2 Jacks - Footplate	J-7
1413250334	F2 A-Frame Jack and Coupler	J-7
141401	XLT Powered Jack	J-6
142001	Single Speed Trailer Winch	L-5
142006	Single Speed Trailer Winch	L-5
142100	Single Speed Trailer Winch	L-5
142102	Single Speed Trailer Winch	L-5
142103	Single Speed Trailer Winch	L-5
142200	Single Speed Trailer Winch	L-5
142203	Single Speed Trailer Winch	L-5
142208	Single Speed Trailer Winch	L-5
142300	Single Speed Trailer Winch	L-5
142305	Single Speed Trailer Winch	L-5
142311	Single Speed Trailer Winch	L-5
142314	Single Speed Trailer Winch	L-5
142400	Two Speed Trailer Winch	L-6
142410	Two Speed Trailer Winch	L-6
142411	Two Speed Trailer Winch	L-6
142415	Two Speed Trailer Winch	L-6
142420	Two Speed Trailer Winch	L-6
142430	Two Speed Trailer Winch	L-6
143001	Brake Winch	L-7
143005	Brake Winch	L-7
143100	Brake Winch	L-7
143104	Brake Winch	L-7
143200	Brake Winch	L-7
14-715810	Trailer Wire Junction Box	C-30
150000	Trailer Jack Without Mount - 2,000 lbs	J-13
150037	Trailer Jack Without Mount - 2,000 lbs	J-13
1500520317	Trailer Jack Without Mount - 2,000 lbs	J-13
1501040301	Trailer Jack - 3,000 lbs	J-11
150152	Trailer Jack Without Mount - 2,000 lbs	J-13
150441	Trailer Jack	J-11
151101	Trailer Weld-On Jack - 2,000 lbs	J-13
151110	Trailer Jack	J-13
151159	Trailer Weld-On Jack - 2,000 lbs	J-13
151401	Trailer Weld-On Jack - 2,000 lbs	J-13
151421	Trailer Weld-On Jack - 2,000 lbs	J-13
151443	Trailer Bolt-On Jack - 2,000 lbs	J-12
151460	Trailer Jack	J-13
151464	Trailer Jack	J-13
154102	Trailer Jack	J-12
154107	Trailer Jack	J-12
1541150301	Trailer Jack Without Mount - 2,000 lbs	J-11
1542S01	Replacement Part - Coupler Repair Kit	K-5
1550100317	A-Frame Trailer Jack - 3,000 lbs	J-12
1550101344	A-Frame Trailer Jack - 3,000 lbs	J-12
155022	A-Frame Trailer Jack - 2,000 lbs	J-12
1550220117	A-Frame Trailer Jack - 2,000 lbs	O-4
155028	A-Frame Trailer Jack - 2,000 lbs	J-12
155032	A-Frame Trailer Jack - 5,000 lbs	J-12
1550320117	A-Frame Trailer Jack - 5,000 lbs	O-4
155033	A-Frame Trailer Jack - 2,000 lbs	J-12
155100	A-Frame Trailer Jack - 2,000 lbs	J-12
155157	A-Frame Trailer Jack - 2,000 lbs	J-12
1551570117	A-Frame Trailer Jack - 2,000 lbs	O-4
158109	Tubular Swivel Trailer Jack - 2,000 lbs	J-11

PART NO.	DESCRIPTION	PAGE NUMBER
1581090301	Tubular Swivel Trailer Jack - 2,000 lbs	J-11
158151	Tubular Swivel Trailer Jack - 2,000 lbs	J-11
1581510117	Tubular Swivel Trailer Jack - 2,000 lbs	J-11
158451	Tubular Swivel Trailer Jack - 2,000 lbs	J-11
158452	Tubular Swivel Trailer Jack - 2,000 lbs	J-11
158488	Tubular Swivel Trailer Jack - 2,000 lbs	J-11
1596S01	Replacement Part - Trailer Winch	L-4
161300†	Trailer Jack Bracket & Wheel	J-36
162300†	Trailer Jack Bracket & Wheel	J-36
165111†	Trailer Jack Bracket & Wheel	J-36
165211†	Trailer Jack Bracket & Wheel	J-36
165311†	Trailer Jack Bracket & Wheel	J-36
165411	Rack and Gear Jacks - 1,200 lbs	J-29
165412†	Rack and Gear Jacks - 1,200 lbs	J-36
169201	Trailer Jack Wheel	J-29
1700100301	A-Frame Trailer Jack - 5,000 lbs	J-12
1700100317	A-Frame Trailer Jack - 5,000 lbs	J-12
1701480317	Trailer Jack Without Mount - 5,000 lbs	J-13
170205	Trailer Jack Without Mount - 5,000 lbs	J-13
171401	Weld-On Swivel Trailer Jack - 5,000 lbs	J-13
171412	Weld-On Swivel Trailer Jack - 5,000 lbs	J-13
1750290301	A-Frame Trailer Jack - 5,000 lbs	J-12
1750290317	A-Frame Trailer Jack - 5,000 lbs	J-12, O-4
178101	Tubular Swivel Trailer Jack - 5,000 lbs	J-11
178151	Tubular Swivel Trailer Jack - 5,000 lbs	J-11
178201	Tubular Swivel Trailer Jack - 5,000 lbs	J-11
178203	Tubular Swivel Trailer Jack - 5,000 lbs	J-11
18004001	4-Flat Connector Harness - Trailer End	C-12
180304	Square Tube Trailer Jack - 10,000 lbs	J-18
180354	Square Tube Trailer Jack - 10,000 lbs	J-18
180405	Square Tube Trailer Jack - 10,000 lbs	J-18
18044001	4-Flat Connector Harness - Loop	C-12
18045001	4-Flat Connector Harness - Loop	C-12
180455	Square Tube Trailer Jack - 10,000 lbs	J-18
180587	Square Tube Trailer Jack - 10,000 lbs	J-18
18185001	4-Flat Connector Harness - Loop	C-12
182300	HD Square Trailer Jacks - 12,000 lbs	J-20
182304	HD Square Trailer Jacks - 12,000 lbs	J-20
1823050383	HD Single Speed Tandem Landing Gear	J-25
1823060383†	HD Single Speed Tandem Landing Gear	J-36
182400	HD Square Trailer Jacks - 12,000 lbs	J-20
182404	HD Square Trailer Jacks - 12,000 lbs	J-20
182411	HD Square Trailer Jacks - 12,000 lbs	J-20
182415	HD Square Trailer Jacks - 12,000 lbs	J-20
1824180100	Powered Trailer Jack - 12,000 lbs	J-22
1824200100	Powered Trailer Jack - 12,000 lbs	J-22
182500	HD Square Trailer Jacks - 12,000 lbs	J-20
182524	HD Square Trailer Jacks - 12,000 lbs	J-19
182700†	HD Square Trailer Jacks - 12,000 lbs	J-23
182701†	HD Square Trailer Jacks - 12,000 lbs	J-23
182800	HD Square Trailer Jacks - 12,000 lbs	J-19
182804	HD Square Trailer Jacks - 12,000 lbs	J-19
182805	HD Square Trailer Jacks - 12,000 lbs	J-19
182815	HD Square Trailer Jacks - 12,000 lbs	J-19
183401	2-Speed Square Trailer Jack	J-24
183416	2-Speed Square Trailer Jack	J-24
183749†	2-Speed Square Trailer Jack	J-23
183750†	2-Speed Square Trailer Jack	J-23
183816	2-Speed Square Trailer Jack	J-24
183900†	2-Speed Square Trailer Jack	J-35
183901	2-Speed Square Trailer Jack	J-24
183902	2-Speed Square Trailer Jack	J-24
183903	2-Speed Square Trailer Jack	J-24
1839050383†	HD 2-Speed Tandem Landing Gear	J-36
1839060383	HD 2-Speed Tandem Landing Gear	J-25
185400	High Speed Trailer Jack	J-21, O-5
185402	High Speed Trailer Jack	J-21, O-5
190704	Square Tube Trailer Jack - 8,000 lbs	J-17
1907040176†	Square Tube Trailer Jack - 8,000 lbs	J-36
190705	Square Tube Trailer Jack - 8,000 lbs	J-17
190706	Square Tube Trailer Jack - 8,000 lbs	J-17

PART NO.	DESCRIPTION	PAGE NUMBER
190708	Square Tube Trailer Jack - 8,000 lbs	J-17
190724	Square Tube Trailer Jack - 8,000 lbs	J-17
190754	Square Tube Trailer Jack - 8,000 lbs	J-17
1907540176	Square Tube Trailer Jack - 8,000 lbs	J-17
190756	Square Tube Trailer Jack - 8,000 lbs	J-17
190758	Square Tube Trailer Jack - 8,000 lbs	J-17
190789†	Square Tube Trailer Jack - 8,000 lbs	J-36
19306	Gooseneck High Rise Hitch Ball	G-9
19307	Gooseneck 3" Hitch Ball	G-9
19308	Gooseneck Offset Hitch Ball	G-9
19309	Replacement Part - Gooseneck	G-9
19310	Replacement Part - Gooseneck Hitch Ball	G-9
19311	Replacement Part - Gooseneck	G-4
19314	Replacement Part - Gooseneck	G-4
19315	Replacement Part - Gooseneck	G-4
1935	Drill Bit	A-9
1937	Hole Saw	A-9
195301	Square Tube Trailer Jack - 5,000 lbs	J-16
195304	Square Tube Trailer Jack - 5,000 lbs	J-16
195306	Square Tube Trailer Jack - 5,000 lbs	J-15
195312	Square Tube Trailer Jack - 5,000 lbs	J-15
195318	Square Tube Trailer Jack - 5,000 lbs	J-16
195319	Square Tube Trailer Jack - 5,000 lbs	J-16
195320	Square Tube Trailer Jack - 5,000 lbs	J-16
195321	Square Tube Trailer Jack - 5,000 lbs	J-16
195351	Square Tube Trailer Jack - 5,000 lbs	J-16
195352	Square Tube Trailer Jack - 5,000 lbs	J-16
195354	Square Tube Trailer Jack - 5,000 lbs	J-16
195356	Square Tube Trailer Jack - 5,000 lbs	J-15
195362	Square Tube Trailer Jack - 5,000 lbs	J-15
195368	Square Tube Trailer Jack - 5,000 lbs	J-16
195369	Square Tube Trailer Jack - 5,000 lbs	J-16
1962	Safety Chain Loop	N-14
198100	Tubular Swivel Trailer Jack - 7,000 lbs	J-11
198150	Tubular Swivel Trailer Jack - 7,000 lbs	J-11
198200	Tubular Swivel Trailer Jack - 7,000 lbs	J-11
198250	Tubular Swivel Trailer Jack - 7,000 lbs	J-11
20000	Battery Case	N-5
20005	Breakaway System	N-3
20010	Breakaway System	N-3
20015	Breakaway System	N-3
20020	Breakaway System	N-3
20034-025	Butt Connectors	C-32
20035-025	Butt Connectors	C-32
20046	Towing Electrical Mount Bracket (2 of 2)	C-29
20059	Trailer Brake Control Mounting Kit	D-7
2005-A	Breakaway Switch	N-4
2005-B120	Breakaway Switch	N-4
2005-P	Breakaway Switch	N-4
20060	Trailer Brake Control Mounting Kit	D-7
2009-A	Breakaway Switch	N-4
2009-A-P	Breakaway Switch	N-4
2009-B60	Breakaway Switch	N-4
2009-P	Breakaway Switch	N-4
2010-A	Breakaway Switch	N-4
2010-A-P	Breakaway Switch	N-4
2010-B125	Breakaway Switch	N-4
2010-P	Breakaway Switch	N-4
20110	7-Way Fifth Wheel Adapter Harness	C-22
20111	7-Way Fifth Wheel Adapter Harness	C-22
20112-024	4-Flat Dust Cover	C-14
20113	7-Way Fifth Wheel Adapter Harness	C-22
20115	Trailer Wire Plug Tester	C-33
20116	Trailer Wire Plug Tester	C-33
20117	Trailer Wire Plug Tester	C-33
20118	5-Flat Dust Cover	C-15
20118-024	5-Flat Dust Cover	C-15
20125	Trailer Connector Adapter - 4 to 7-Way	C-23
20127	Replacement Part - Brake Control Wiring	D-7
20127-012	Replacement Part - Brake Control Wiring	D-7
20128	4/6-Way Adapter Harness	C-21

PART NO.	DESCRIPTION	PAGE NUMBER
20129	4/6-Way Adapter Harness	C-21
20131	4/7-Way Adapter Harness	C-21
20135	Tow Harness Wiring Package	C-5
20136	Trailer Connector Adapter - 4 to 5-Flat	C-26
20137	Tow Harness Wiring Package	C-5
20140	7-Way Fifth Wheel Adapter Harness	C-21
20141	Trailer Connector Adapter - 7 to 5-Flat	C-26
20142	Trailer Connector Adapter - 7 to 7-Way	C-26
20145	Trailer Wire Circuit Tester	C-33
20145-010	Trailer Wire Circuit Tester	C-33
20146	7-Way Fifth Wheel Adapter Harness	C-22
20147	7-Way Connector Harness - Vehicle End	C-22
20160	Brake Control Wiring - Universal Harness	D-7
20160-012	Brake Control Wiring - Universal Harness	D-7
20174	Cargo Carrier Light Kit	I-13
2018	Battery Case	N-5
20191†	Trailer Brake Control - Proportional	D-4
20212	Towing Electrical Mount Bracket (2 of 2)	C-29
20212-010	Towing Electrical Mount Bracket	C-29
20223	7-Way Connector Harness - Vehicle End	C-21
20224	7-Way Connector Harness - Vehicle End	C-21
2023	Breakaway Battery	N-5
2023-X	Breakaway Battery	N-5
2024-07	Breakaway Charger	N-5
2024-07-S	Breakaway Charger	N-5
20250	4-Flat Connector Harness - Vehicle End	C-10
2025-09	Breakaway Charger	N-5
20251	4-Flat Connector Harness - Vehicle End	C-10
20252	4-Flat Connector Harness - Vehicle End	C-10
2026	Breakaway System	N-3
2028	Breakaway System	N-3
203111	Clearance Lights w/ Reflex Lens	M-20, M-35
203113	Clearance Lights w/ Reflex Lens	M-35
203116	Clearance Lights w/ Reflex Lens	M-35
203117	Clearance Lights w/ Reflex Lens	M-23, M-35
203131	Clearance Lights w/ Reflex Lens	M-35
203133	Clearance Lights w/ Reflex Lens	M-35
20320	Trailer Connector Adapter - 4 to 6-Way	C-23
20320-012	Trailer Connector Adapter - 4 to 6-Way	C-23
20321†	Trailer Connector Adapter - 4 to 7-Way	C-34
20321-012	Trailer Connector Adapter - 4 to 7-Way	C-23
20322	Trailer Connector Adapter - 4 to 7-Way	C-23
203233	Waterproof Clearance Lights	M-32
203234	Waterproof Clearance Lights	M-32
203235	Clearance / Side Marker Lights	M-37
203285	Waterproof Clearance Lights	M-32
203286	Waterproof Clearance Lights	M-32
203292	Waterproof Clearance Lights #37 Series	M-31
203293	Waterproof Clearance Lights #37 Series	M-31
203294	Waterproof Clearance Lights #37 Series	M-31
203295	Waterproof Clearance Lights #37 Series	M-31
203315	Waterproof ID Light Bars	M-40
203380	Replacement Part	M-30
203381	Replacement Part	M-30
203395	Replacement Part	M-31
203396	Replacement Part	M-31, M-40
20501	Pulse Preventor	D-7
20505	Brake Control Wiring Kit	D-6
20506	Brake Control Wiring Kit	D-6
2051	Battery Case	N-5
2060266	Ratchet Tie Down Strap	I-15
2060466	Cambuckle Tie Down Strap	I-15
2060866	Ratchet Tie Down Strap	I-15
2061366	Ratchet Tie Down Strap	I-15
2061566	Ratchet Tie Down Strap	I-15
2061766	Ratchet Tie Down Strap	I-15
21141	Trailer Hitch Adjustable Ball Mount	B-14
2120	4-Flat Connector Harness - Trailer End	C-12
2125	4-Flat Connector Harness - Trailer End	C-12
2130	4-Flat Connector Harness - Trailer End	C-12
21501	Replacement Part - WD	E-8, E-10, E-11



PRODUCT INDEX

PART NO.	DESCRIPTION	PAGE NUMBER
2178	Trailer Brake Control Mounting Kit	D-7
2211	Trailer Hitch Tube Cover	B-24
22111	Tow Harness Wiring Package	C-6
22112	Tow Harness Wiring Package	C-6
22113	Tow Harness Wiring Package	C-6
22114	Tow Harness Wiring Package	C-6
22115	Tow Harness Wiring Package	C-6
22116	Tow Harness Wiring Package	C-6
22117	Tow Harness Wiring Package	C-6
22119	Tow Harness Wiring Package	C-6
22121	Tow Harness Wiring Package	C-6
221588	Replacement Part	M-26, M-27, M-31
22200 0101	Straight Trailer Coupler	K-11
222012	Trailer Light Lens	M-24
22225	Replacement Part - WD	E-11
22300 0101	Straight Trailer Coupler	K-11
223117	Clearance Lights w/ Reflex Lens	M-23, M-35
223210	Waterproof License Plate Light	M-40
225501	Tow Harness Wiring Package	C-34
22551	Tow Harness Wiring Package	C-6
23227	Replacement Part - WD	E-11
2423006	Submersible Under 80" Taillights	M-21
2423008	Submersible Over 80" Taillights	M-19
2423056	Submersible Under 80" Taillights	M-21
2423058	Submersible Over 80" Taillights	M-19
2423273	Pedestal Mount Taillight	M-17
2423274	Pedestal Mount Taillight	M-17
2423275	Pedestal Mount Taillight	M-17
2423283	Combination Taillights #80 Series	M-18
2423284	Combination Taillights #80 Series	M-18
2423286	Replacement Part	M-17, M-18, M-19, M-21
2423287	Replacement Part	M-17, M-19, M-21
2423293	Combination Taillights #80 Series	M-17
2423294	Combination Taillights #80 Series	M-17
2423297	Replacement Part	M-18
2423500	Submersible Taillight Kit	M-19
2471	Replacement Part - Tow Bar	N-14
2489	Trailer Hitch Safety Chain	N-13
24899	Class I Trailer Hitch	O-2
2523023	Submersible Under 80" Taillights	M-21
2523024	Submersible Over 80" Taillights	M-19
2523073	Submersible Under 80" Taillights	M-21
2523074	Submersible Over 80" Taillights	M-19
2527511	Submersible Under 80" Taillight Kit	M-21
26002	Sway Control - Dual Cam	E-6, O-2
26003	Sway Control Adapter Bracket	E-8
26005	Sway Control Adapter Bracket	E-8
2706	Class III Trailer Hitch Ball Mount	B-7
271574	LED Waterproof Taillights	M-8
271575	LED Waterproof Taillights	M-8
271584	LED Waterproof Taillights	M-9
271584-01	LED Waterproof Taillights	M-9
271585	LED Waterproof Taillights	M-9
271585-01	LED Waterproof Taillights	M-9
271594	LED Waterproof Taillights	M-8
271595	LED Waterproof Taillights	M-8
273006	LED Submersible Taillights	M-11
273008	LED Submersible Taillights	M-12
273056	LED Submersible Taillights	M-11
273058	LED Submersible Taillights	M-12
273560	LED Waterproof 6" Oval Taillights	M-24
273561	LED Waterproof 6" Oval Taillights	M-11
273564	LED Waterproof 6" Oval Taillights	M-11
273565	LED Waterproof 6" Oval Taillights	M-11
2736	Class III Trailer Hitch Ball Mount	B-7
2736-006†	Class III Trailer Hitch Ball Mount	B-26
2793	Class III Trailer Hitch Ball Mount	B-7
2793-002†	Class III Trailer Hitch Ball Mount	B-26
281500	LED Submersible Taillight Kit	M-8
281594	LED Waterproof Taillights	M-8

PART NO.	DESCRIPTION	PAGE NUMBER
281595	LED Waterproof Taillights	M-8
2823283	Combination Taillights #80 Series	M-18
2823284	Combination Taillights #80 Series	M-18
2823285	Combination Taillights #80 Series	M-18
2823293	Combination Taillights #80 Series	M-17
2823294	Combination Taillights #80 Series	M-17
283006	LED Submersible Combination Taillights	M-11
283008	LED Submersible Taillights	M-12
283056	LED Submersible Combination Taillights	M-11
283058	LED Submersible Taillights	M-12
283500	LED Submersible Taillights	M-12
283561	LED Waterproof 6" Taillights	M-11
283564	LED Waterproof 6" Taillights	M-11
283565	LED Waterproof 6" Taillights	M-11
28451	Class I Trailer Hitch Drawbar Kit	B-6
2850	Trailer Hitch Receiver Tube	A-9
2851	Trailer Hitch Receiver Tube	A-9
2852	Trailer Hitch Receiver Tube	A-9
2853	Trailer Hitch Receiver Tube	A-9
2854	Trailer Hitch Receiver Tube	A-9
287512	LED Submersible Taillight Kit	M-11
2898	Trailer Hitch Receiver Tube	A-9
2923	Class IV Trailer Hitch Ball Mount	B-7
2953	Class IV Trailer Hitch Ball Mount	B-7
30033†	Fifth Wheel Trailer Hitch - 22K	F-12, F-20
30035	Fifth Wheel Trailer Hitch Rail Kit	F-11, O-3
30035-040	Fifth Wheel Trailer Hitch Rail Kit	F-11
30047	Fifth Wheel Trailer Hitch - 16K	F-3, F-12
30047A	Replacement Part - Fifth Wheel	F-3
30048	Fifth Wheel Trailer Hitch Slider	F-7
30051	Fifth Wheel Trailer Hitch - 16K	F-3, F-12
30053	Fifth Wheel Trailer Hitch Starter Kit	F-8
30054	Fifth Wheel Trailer Hitch - 30K	F-4, F-12
30055	Fifth Wheel Trailer Hitch Cover	F-8
3006	Trailer Hitch Receiver Tube	A-9
30-073833	Clearance Lights 2-3/4" Round	M-36
30-073834	Clearance Lights 2-3/4" Round	M-36
30075	Fifth Wheel Trailer Hitch - 16K	F-3, F-12
30081†	Fifth Wheel Trailer Hitch - 20K	F-12, F-19, O-3
30083†	Fifth Wheel Trailer Hitch - 20K	F-12, F-19
30084†	Fifth Wheel Trailer Hitch - 20K	F-12, F-19
30092†	Fifth Wheel Trailer Hitch Slider	F-20
30093†	Fifth Wheel Trailer Hitch - 15K	F-12, F-19
30094†	Fifth Wheel Trailer Hitch - 15K	F-12, F-19
30099†	Fifth Wheel Trailer Hitch - 15K	F-19
30105	6 Pole Square Connector Kit	C-16
30118	Fifth Wheel Trailer Hitch - 20K	F-4
30119	Fifth Wheel Trailer Hitch - 20K	F-4, F-12
30121†	Fifth Wheel Trailer Hitch - 20K	F-12, F-19
30126	Fifth Wheel Trailer Hitch Rail Kit	F-12, O-3
30128†	Fifth Wheel Trailer Hitch - 15K	F-19
30129†	Fifth Wheel Trailer Hitch - 15K	F-19
30132	Fifth Wheel Trailer Hitch - 20K	F-4
30133†	Fifth Wheel Trailer Hitch - 20K	F-19
30134	Replacement Part - Gooseneck	G-4
30135	Replacement Part - Gooseneck	G-4
30136	Replacement Part - Gooseneck	G-4
30137	Gooseneck Trailer Hitch Accessory Kit	G-4
30138	Gooseneck Trailer Hitch Head	G-3
30138-26	Gooseneck Trailer Hitch	G-3
30140	Gooseneck Trailer Hitch Accessory Kit	G-4
30142†	Fifth Wheel Trailer Hitch - 18K	F-12, F-19, O-3
30143†	Fifth Wheel Trailer Hitch - 25K	F-12, F-19
30144†	Fifth Wheel Trailer Hitch - 18K	F-12, F-19, O-3
30145	Replacement Part - Gooseneck	G-4
30153	Fifth Wheel Trailer Hitch Rails	F-10, F-12, O-3
30154	Fifth Wheel Trailer Hitch Adapter Kit	F-5, F-12
30156	Fifth Wheel Trailer Hitch Adapter Kit	F-5, F-12
30158	Gooseneck Trailer Hitch Head	G-3
30158-52	Gooseneck Trailer Hitch	G-3
30158-68	Gooseneck Trailer Hitch	G-3

PART NO.	DESCRIPTION	PAGE NUMBER
30160	Fifth Wheel Trailer Hitch - 20K	F-3, F-12
30-17-034	Replacement Part - Lights	M-33
30-17-814	Clearance/Side Marker Lights #178 Series	M-33
30-17-815	Clearance/Side Marker Lights #178 Series	M-33
30416	Replacement Part - Fifth Wheel	F-16, F-17
30439	Replacement Part - Fifth Wheel	F-18
30579	Replacement Part - Fifth Wheel	F-16, F-17
30-58-001	Clearance/Side Marker Lights #58 Series	M-33
30-58-002	Clearance/Side Marker Lights #58 Series	M-33
30-58-007†	Clearance/Side Marker Lights #58 Series	M-33
30-58-010	Replacement Part	M-33
30-58-012	Replacement Part	M-33
30-58-024	Replacement Part	M-33, M-34
30-58-702	Replacement Part	M-33, M-34
30-59-001	Clearance/Side Marker Lights #59 Series	M-34
30-59-002	Clearance/Side Marker Lights #59 Series	M-34
30-59-003	Clearance/Side Marker Lights #59 Series	M-34
30-59-004	Clearance/Side Marker Lights #59 Series	M-34
30-59-010	Replacement Part	M-34
30-59-012	Replacement Part	M-34
30-59-054	Replacement Part - Lights	M-33, M-34
30-60-004	Cargo Dome Light	M-45
30-60-005	Utility Light	M-45
30-62-000	License Plate Lights	M-41
30-62-002	License Plate Lights #62 Series	M-41
30-62-003	License Plate Lights #62 Series	M-41
30-62-030	License Plate Brackets	M-41, M-42
30-62-102	License Plate Lights #62 Series	M-41
30-62-103	License Plate Lights #62 Series	M-41
30-72-100	License Plate Brackets	M-42
30727	Replacement Part - Fifth Wheel	F-3, F-15, F-16
30730	Replacement Part - Fifth Wheel	F-17
30-76-028	Replacement Part	M-44
30-76-123	Interior Lights #76 Series	M-44
30-76-223	Interior Lights #76 Series	M-44
30-76-243	Interior Lights #76 Series	M-44
30776	Replacement Part - Fifth Wheel	F-16, F-17
30-78-021	Replacement Part	M-44
30-78-022	Replacement Part	M-44
30-78-515	Porch / Utility Lights #78 Series	M-44
30-78-516	Porch / Utility Lights #78 Series	M-44
30-78-517	Porch / Utility Lights #78 Series	M-44
30-78-518	Porch / Utility Lights #78 Series	M-44
30-78-522	Porch / Utility Lights #78 Series	M-44
30-78-523	Porch / Utility Lights #78 Series	M-44
30-78-524	Porch / Utility Lights #78 Series	M-44
30-78-525	Porch / Utility Lights #78 Series	M-44
30-78-600	Porch / Utility Lights #78 Series	M-44
308 0217	Straight Trailer Coupler	K-12
30-84-001	Recessed Double Taillights #84 Series	M-14
30-84-002	Recessed Triple Taillights #84/85 Series	M-15
30-84-008	Recessed Double Taillights #84 Series	M-14
30-84-009	Recessed Triple Taillights #84/85 Series	M-15
30-84-057	Replacement Bulbs	M-13, M-14, M-15, M-16, M-20, M-45
30-84-075	Replacement Part - Lights	M-13, M-14, M-15, M-30, M-34
30-84-103	Recessed Taillights #84 Series	M-15
30-84-104	Recessed Taillights #84 Series	M-15
30845	Gooseneck Trailer Hitch	F-6, G-8
30-84-508	Recessed Double Taillights #84 Series	M-14
30-84-509	Recessed Triple Taillights #84/85 Series	M-15
30-84-523	Recessed Triple Taillights #84/85 Series	M-15
30-84-527	Recessed Double Taillights #84 Series	M-14
30-84-529	Recessed Double Taillights #84 Series	M-14
30-84-540	Recessed Double Taillights #84 Series	M-14
30-84-547	Recessed Double Taillights #84 Series	M-14
30-84-554	Recessed Taillights #84 Series	M-15
30850	Fifth Wheel Wedge Kit	H-6
30-85-002	Recessed Triple Taillights #84/85 Series	M-15
30852	Fifth Wheel Trailer Hitch Rail Kit	F-12

PART NO.	DESCRIPTION	PAGE NUMBER
30-86-005	Clearance/Side Marker Lights #86 Series	M-13
30861	Fifth Wheel Wedge Kit	H-6
30-86-101	Single Taillights #86 Series	M-13
30-86-103	Single Taillights #86 Series	M-13
30-86-107	Single Taillights #86 Series	M-13
30862†	Fifth Wheel Trailer Hitch - 25K	F-12, F-20
30-86-202	Clearance/Side Marker Lights #86 Series	M-34
30-86-203	Clearance/Side Marker Lights #86 Series	M-34
30863	Replacement Part - Fifth Wheel	F-3
30864	Replacement Part - Fifth Wheel	F-3
30865	Fifth Wheel Wedge Kit	H-6
30-86-711	Replacement Part	M-30, M-34
30-86-712	Replacement Part	M-30, M-34
30868	Fifth Wheel Trailer Hitch Rail Kit	F-12
30871†	Fifth Wheel Trailer Hitch - 26.5K	F-12, F-19, O-3
30884	Fifth Wheel Center Section	F-2
30887	Replacement Part - Gooseneck	G-4
30888	Replacement Part - Gooseneck	G-4
30889	Fifth Wheel GM Leg Kit	F-2
30890	Fifth Wheel Trailer Hitch - 20K	F-2, F-12
30892	Fifth Wheel Head	F-2
30894	Fifth Wheel Center Section	F-2
30895	Fifth Wheel Trailer Hitch - 27K	F-2
30-90-021	Replacement Bulbs	M-44, M-45
30-90-156	Replacement Bulbs	M-13, M-14, M-15, M-16, M-17, M-43, M-45
30-90-157	Replacement Bulbs	M-17, M-18, M-19, M-21, M-23, M-45, M-48
30917	Fifth Wheel RAM Leg Kit	F-2
30918	Fifth Wheel Trailer Hitch - 20K	F-2
30919	Fifth Wheel Trailer Hitch - 27K	F-2
30-92-001	Surface Mount Taillights #92 Series	M-16
30-92-002	Surface Mount Taillights #92 Series	M-16
30-92-003	Surface Mount Taillights #92 Series	M-16
30-92-004	Surface Mount Taillights #92 Series	M-16
30-92-012	Replacement Part	M-16
30-92-044	Wedge Base for #92 Series Taillights	M-16
30921	Fifth Wheel Trailer Hitch - 20K	F-2
30-92-106	Surface Mount Taillights #92 Series	M-16
30-92-107	Surface Mount Taillights #92 Series	M-16
30-92-108	Surface Mount Taillights #92 Series	M-16
30-92-109	Surface Mount Taillights #92 Series	M-16
30922	Fifth Wheel Trailer Hitch - 27K	F-2
30923	Fifth Wheel Ford Leg Kit	F-2
30926	Fifth Wheel Leg Kit	F-2
30927	Fifth Wheel Leg Kit	F-2
30-92-704	Replacement Part	M-16
30-92-708	Replacement Part	M-16
30-92-713	Replacement Part	M-16
30928	Fifth Wheel Trailer Hitch - 20K	F-2
30929	Fifth Wheel Trailer Hitch - 27K	F-2
30-99-001	Clearance/Side Marker Lights #99 Series	M-36
30-99-002	Clearance/Side Marker Lights #99 Series	M-36
30-99-010	Replacement Part	M-36
30-99-012	Replacement Part	M-36
31016	Fifth Wheel Wedge Kit	H-6
31-2823285	Under 80" Trailer Light Kit #80 Series	M-18
3132†	Cooler Accessories	N-17
31-407540	LED Waterproof Taillight Kit	M-8
31-407560	LED Waterproof Taillight Kit	M-9
31-59-001	Clearance/Side Marker Lights #59 Series	M-34
31-59-002	Clearance/Side Marker Lights #59 Series	M-34
31-59-010	Replacement Part	M-34
31-59-012	Replacement Part	M-34
31-78-531	Porch / Utility Lights #78 Series	M-44
31-84-010	Replacement Part	M-13, M-14, M-15
31-84-016	Replacement Part	M-13, M-14, M-15
31-84-700	Replacement Part	M-13, M-14, M-15
31-84-711	Replacement Part	M-13, M-14, M-15

PRODUCT INDEX

PART NO.	DESCRIPTION	PAGE NUMBER
31-86-101	Single Taillights #86 Series	M-13
31-86-103	Single Taillights #86 Series	M-13
31-92-001	Surface Mount Taillights #92 Series	M-16
31-92-003	Surface Mount Taillights #92 Series	M-16
3194-S	Battery Post Adapter	C-31
31-99-001	Clearance/Side Marker Lights #99 Series	M-36
31-99-002	Clearance/Side Marker Lights #99 Series	M-36
31-99-215	Waterproof ID Light Bar	M-40
32-003440	Dual Bulb Clearance / Side Marker Lights	M-36
32-003441	Dual Bulb Clearance / Side Marker Lights	M-36
3214	Weight Distributing Shank	E-7
3215	Weight Distributing Shank	E-7
323356	Rectangular Reflectors	M-42
323357	Rectangular Reflectors	M-42
3280	Pole Tongue Adapter	E-7
33305H0301	A-Frame Trailer Coupler	K-12
3344	Weight Distributing Shank	E-7
34-108663	Replacement Part - Lights	M-26, M-27, M-30, M-31, M-40
34141	Safety Chain Loop	N-14
34-17-034	Replacement Part - Lights	M-33
34-17-808	Clearance/Side Marker Lights #178 Series	M-33
34-17-809	Clearance/Side Marker Lights #178 Series	M-33
34300 0301	Straight Trailer Coupler	K-11
34300 0317	Straight Trailer Coupler	K-11
3442	Replacement Part - WD	E-7
34-58-001	Clearance/Side Marker Lights #58 Series	M-33
34-58-002	Clearance/Side Marker Lights #58 Series	M-33
34-58-010	Replacement Part	M-33
34-58-012	Replacement Part	M-33
34-59-001	Clearance/Side Marker Lights #59 Series	M-34
34-59-002	Clearance/Side Marker Lights #59 Series	M-34
34-59-010	Replacement Part	M-34
34-59-012	Replacement Part	M-34
34600 0301	Straight Trailer Coupler	K-11
34-62-000	License Plate Lights	M-41
34-62-002	License Plate Lights #62 Series	M-41
34-62-003	License Plate Lights #62 Series	M-41
34-62-030	License Plate Brackets	M-41, M-42
34-62-102	License Plate Lights #62 Series	M-41
34-62-103	License Plate Lights #62 Series	M-41
34-72-100	License Plate Brackets	M-42
34-76-028	Replacement Part	M-44
34-76-123	Interior Lights #76 Series	M-44
34-76-223	Interior Lights #76 Series	M-44
34-76-243	Interior Lights #76 Series	M-44
34-78-021	Replacement Part	M-44
34-78-022	Replacement Part	M-44
34-78-515	Porch / Utility Lights #78 Series	M-44
34-78-517	Porch / Utility Lights #78 Series	M-44
34-78-518	Porch / Utility Lights #78 Series	M-44
34-84-008	Recessed Double Taillights #84 Series	M-14
34-84-009	Recessed Triple Taillights #84/85 Series	M-15
34-84-010	Replacement Part	M-13, M-14, M-15
34-84-016	Replacement Part	M-13, M-14, M-15
34-84-527	Recessed Double Taillights #84 Series	M-14
34-84-700	Replacement Part	M-13, M-14, M-15
34-84-711	Replacement Part	M-13, M-14, M-15
34-85-750	Replacement Part	M-14, M-15
34-86-101	Single Taillights #86 Series	M-13
34-86-202	Wrap-Around Lights #86 Series	M-13, M-34
34-86-203	Wrap-Around Lights #86 Series	M-13, M-34
34-86-711	Replacement Part	M-13, M-30, M-34
34-86-712	Replacement Part	M-13, M-30, M-34
34-92-001	Surface Mount Taillights #92 Series	M-16
34-92-002	Surface Mount Taillights #92 Series	M-16
34-92-003	Surface Mount Taillights #92 Series	M-16
34-92-012	Replacement Part	M-16
34-92-704	Replacement Part	M-16
34-92-708	Replacement Part	M-16
34-92-713	Replacement Part	M-16

PART NO.	DESCRIPTION	PAGE NUMBER
34-99-001	Clearance/Side Marker Lights #99 Series	M-36
34-99-002	Clearance/Side Marker Lights #99 Series	M-36
34-99-010	Replacement Part	M-36
34-99-012	Replacement Part	M-36
3590	Class I Trailer Hitch Drawbar Kit	B-6
3591	Class I Trailer Hitch Drawbar Kit	B-6
3592	Class I Trailer Hitch Drawbar Kit	B-6
3593	Class I Trailer Hitch Drawbar Kit	B-6
3594	Class I Trailer Hitch Drawbar Kit	B-6
36010†	Motorhome Hitch	A-143
36051	Class II Trailer Hitch Drawbar Kit	B-6
36053	Class II Trailer Hitch Drawbar Kit	B-6
36061	Class II Trailer Hitch Drawbar Kit	B-6
36063	Class II Trailer Hitch Drawbar Kit	B-6
36065	Class II Trailer Hitch Drawbar Kit	B-6
36071	Class II Trailer Hitch Drawbar Kit	B-6
36078	Class II Trailer Hitch Drawbar Kit	B-6
36423	Class II Trailer Hitch	O-2
37-0023	Point of Purchase Display	O-5
37-0030	Point of Purchase Display	O-2
37-2075	Aluminum Sign	O-5
37-2103	Point of Purchase Display	O-3
37-2109	Point of Purchase Display	O-2
37-2112	Point of Purchase Display	O-6
37-2114	Point of Purchase Display	O-6
37-2126	Point of Purchase Display	O-4
37-2127	Point of Purchase Display	O-6
37-2130	Point of Purchase Display	O-3
37-2131	Point of Purchase Display	O-6
37-2132	Point of Purchase Display	O-6
37-2133	Point of Purchase Display	O-6
37-2134	Point of Purchase Display	O-4, O-6
37-3016	Point of Purchase Display	O-5
38023	Class V Trailer Hitch	A-7
3808	Trailer Wire Circuit Tester	C-33
38124	Class V Trailer Hitch	A-7
38180	Dual-Ball Trailer Hitch Ball Mount	B-11
38186	Pintle Hook Mounting Plate	B-17
38208	Class V Trailer Hitch	A-7
38211	Class V Trailer Hitch	A-7
38665-012	Trailer Wire Relay	C-32
38666-010	Trailer Wire Relay	C-32
38667-010	Trailer Wire Relay	C-32
38735	Ball Mount Reducer Bushing	B-15
40-00-002	Replacement Part - Lights	M-26, M-27, M-30, M-31, M-40
40-00-003	Replacement Part	M-10, M-11, M-19, M-21, M-24, M-37
40-00-004	Replacement Part	M-8, M-9, M-10, M-11, M-19, M-21, M-24, M-37
40-00-005	Replacement Part - Lights	M-28
40-00-006	Replacement Part	M-9
40-01-001	Replacement Part	M-19
40-01-003	Replacement Part	M-19
40-01-020	Replacement Part	M-19
40-01-020	Replacement Part	M-9
40058-002	Trailer Hitch Starter Ball Mount Kit	B-9
40-06-001	Replacement Part	M-21
40-06-020	Replacement Part	M-10, M-11, M-21, M-24, M-37
40109	Drill Bit	A-9
40110	Drill Bit	A-9
401565	LED Waterproof Clearance Lights	M-27
401566	LED Waterproof Clearance Lights	M-27, M-39
401567	LED Waterproof Clearance Lights	M-39
401580	Replacement Part	M-27
401581	Replacement Part	M-27
401582	Replacement Part	M-28
401583	Replacement Part	M-28
401584	Replacement Part	M-10

PART NO.	DESCRIPTION	PAGE NUMBER
401585	LED Clearance Lights #58 Series	M-28
401586	LED Clearance Lights #58 Series	M-28
401589	Replacement Part - Lights	M-30
401591	Replacement Part	M-10, M-11, M-21, M-24, M-37
40200	Class V Trailer Hitch Ball Mount	B-10
40201	Class V Trailer Hitch Ball Mount	B-10
40202	Class V Trailer Hitch Ball Mount	B-10
40205	Class V Trailer Hitch Ball Mount	B-10
40206	Class V Trailer Hitch Ball Mount	B-10
40238-002	Trailer Hitch Starter Ball Mount Kit	B-9
40-30-001	Replacement Part	M-30
40-30-002	Replacement Part	M-30
40-30-020	Replacement Part - Lights	M-30
403025	Submersible 4X6 Over 80" Taillights	M-23
403026	Waterproof Taillights	M-20
403075	Submersible 4X6 Over 80" Taillights	M-23
403076	Waterproof Taillights	M-20
403080	Waterproof Recessed Taillights	M-21
403085	Replacement Part	M-21
40330	Class V Trailer Hitch Ball Mount	B-10
40330-002†	Class V Trailer Hitch Ball Mount	B-27
40331	Class V Trailer Hitch Ball Mount	B-10
40331-002†	Class V Trailer Hitch Ball Mount	B-27
40332	Class V Trailer Hitch Ball Mount	B-10
40332-002†	Class V Trailer Hitch Ball Mount	B-27
403336	Replacement Part	M-20
40342	Class IV Trailer Hitch Ball Mount	B-7
40342-006†	Class IV Trailer Hitch Ball Mount	B-26
40343	Class IV Trailer Hitch Ball Mount	B-7
40343-006†	Class IV Trailer Hitch Ball Mount	B-26
40344	Class IV Trailer Hitch Ball Mount	B-7
40344-006†	Class IV Trailer Hitch Ball Mount	B-26
40345	Class IV Trailer Hitch Ball Mount	B-7
40345-006†	Class IV Trailer Hitch Ball Mount	B-26
40346	Class IV Trailer Hitch Ball Mount	B-7
40346-002†	Class IV Trailer Hitch Ball Mount	B-26
40-37-001	Replacement Part	M-31, M-40
40-37-002	Replacement Part	M-31
40-37-020	Replacement Part	M-27, M-31
40376	Trailer Wire Circuit Tester	C-33
40-38-001	Replacement Part	M-32
40-38-002	Replacement Part	M-32
40-38-004	Waterproof Side Marker Lights #38 Series	M-32
40-38-020	Replacement Part	M-28, M-32
40-38-025	Replacement Part	M-28, M-32
40381	Class IV Trailer Hitch Ball Mount	B-10
4038188	Class III Trailer Hitch Ball Mount	B-9
40382	Class IV Trailer Hitch Ball Mount	B-10
4038288	Class III Trailer Hitch Ball Mount	B-9
40383	Class IV Trailer Hitch Ball Mount	B-10
4038388	Class III Trailer Hitch Ball Mount	B-9
40384	Class IV Trailer Hitch Ball Mount	B-10
40-40-004	Fender Mount Lights #40 Series	M-37
40-40-104	Fender Mount Light	M-37
40-40-115	Accessory Part	M-37
40-40-120	Accessory Part	M-32, M-36
40443†	Class IV Trailer Hitch Ball Mount	B-25
40446†	Class IV Trailer Hitch Ball Mount	B-25
40565	Trailer Hitch Starter Ball Mount Kit	B-9
40583-002	Trailer Hitch Starter Ball Mount Kit	B-9
40584-002†	Trailer Hitch Starter Ball Mount Kit	B-26
40-60-001	Security / Utility Lights	M-43
40-60-004	Security / Utility Lights	M-43
40602	Tow Bar Bracket Chain	N-14
40604	Tow Bar Safety Chain Kit	N-14
40644-002	Trailer Hitch Starter Ball Mount Kit	B-9
40700	3" Trailer Hitch Ball Mount	B-11
40701	3" Trailer Hitch Ball Mount	B-11
40702	3" Trailer Hitch Ball Mount	B-11
40703	3" Trailer Hitch Ball Mount	B-11

PART NO.	DESCRIPTION	PAGE NUMBER
407500	Combination Trailer Light Kit #80 Series	M-18
407515	Submersible 4X6 Over 80" Taillight Kit	M-23
407530	LED Waterproof Taillights	M-8
407535	LED Waterproof Taillights	M-8
407540	LED Waterproof Taillight Kit	M-8
407550	LED Waterproof Taillights	M-9
407555	LED Waterproof Taillights	M-9
407560	LED Waterproof Taillight Kit	M-9
40-767758	LED Waterproof 6" Taillights	M-10
41011†	Transmission Cooler Kit - Tube	N-17
41013†	Transmission Cooler Kit - Tube	N-17
41014†	Transmission Cooler Kit - Tube	N-17
41019†	Transmission Cooler Kit - Plate	N-17
41020†	Transmission Cooler Kit - Plate	N-17
41103†	Transmission Cooler Kit - Metal Strap	N-17
41-30-001	Replacement Part	M-30
41-30-002	Replacement Part	M-30
41310†	Transmission Cooler Kit - Plate	N-17
41311†	Transmission Cooler Kit - Plate	N-17
41312†	Transmission Cooler Kit - Plate	N-17
413560	Waterproof Taillights #06 Series	M-21
41-37-031	Waterproof Lights #37 Series	M-31
41-37-032	Waterproof Lights #37 Series	M-31
41-38-031	Waterproof Lights #38 Series	M-32
41-38-032	Waterproof Lights #38 Series	M-32
41405†	Transmission Cooler Kit - Nylon Tie	N-17
41410†	Transmission Cooler Line Fitting Kit	N-17
41412†	Transmission Cooler Line Fitting Kit	N-17
416088	Replacement Part	M-10, M-11, M-21, M-24, M-37
417515	Submersible 4X6 Over 80" Taillight Kit	M-23
41946	Class V Trailer Hitch	O-2
41990	Service Body Receiver	A-6
41990-07	Class V Trailer Hitch	A-6
41990-16	Class V Trailer Hitch	A-6
41991	Service Body Receiver	A-6
41991-07	Class V Trailer Hitch	A-6
41991-16	Class V Trailer Hitch	A-6
42-106858	LED Waterproof Clearance Lights	M-39
42250†	Trailer Hitch Ball Cover	B-29
42250-012†	Trailer Hitch Ball Cover	B-29
42251	Trailer Hitch Ball Cover	B-24
42251-012†	Trailer Hitch Ball Cover	B-29
423025	Submersible 4X6 Over 80" Taillights	M-23
423075	Submersible 4X6 Over 80" Taillights	M-23
4234	Safety Chain Loop	N-14
42-37-401	Replacement Part	M-27, M-39
42-37-402	Replacement Part	M-27
42-38-033	LED Lights #38 Series	M-28
42-38-034	LED Lights #38 Series	M-28
42-59-401	LED Lights #59 Series	M-29
42-59-402	LED Lights #59 Series	M-29
42-59-410	LED Upgrade Kits #59 Series	M-29
42-59-412	LED Upgrade Kits #59 Series	M-29
4280	Class V Trailer Hitch Ball Mount	B-10
4281	Class V Trailer Hitch Ball Mount	B-10
4282	Class V Trailer Hitch Ball Mount	B-10
4283	Class V Trailer Hitch Ball Mount	B-10
4284	Class V Trailer Hitch Ball Mount	B-10
42-84-410	LED Upgrade Kits #84/85 Series	M-3
42-84-412	LED Upgrade Kits #84/85 Series	M-3
4285	Class V Trailer Hitch Ball Mount	B-10
42-86-101	LED Single Taillights #86 Series	M-4
42-86-410	LED Upgrade Kits #86 Series	M-3, M-30
42-86-412	LED Upgrade Kits #86 Series	M-3, M-30
42-99-215	LED Waterproof ID Light Bar	M-39
42-99-401	LED Waterproof Lights #99 Series	M-26
42-99-402	LED Waterproof Lights #99 Series	M-26
43805W0317	A-Frame Trailer Coupler	K-8
44-00-002	Replacement Part - Lights	M-26, M-27, M-30, M-31, M-40

PRODUCT INDEX

PART NO.	DESCRIPTION	PAGE NUMBER
44-01-031	Waterproof Taillights #01 Series	M-19
44-06-001	Replacement Part	M-21
44-06-031	Waterproof Taillights #06 Series	M-21
44125W0317	A-Frame Trailer Coupler	K-8
44133†	Trailer Hitch Safety Chain Link	N-18
44140†	Trailer Hitch Safety Chain Link	N-18
44150W0317	A-Frame Trailer Coupler	K-8
44150WH301	A-Frame Trailer Coupler	K-8
44150WQ317	A-Frame Trailer Coupler	K-8
44154†	Clevis Slip Hook	N-18
44155	Clevis Slip Hook	N-14
44156†	Clevis Slip Hook	N-18
44157†	Clevis Slip Hook	N-18
44159†	Clevis Slip Hook	N-18
44163†	Clevis Slip Hook	N-18
44164†	Clevis Slip Hook	N-18
4420000317	Flat Mount Trailer Coupler Plate	K-8
4425000317	Flat Mount Trailer Coupler Plate	K-8
44-30-001	Replacement Part	M-30
44-30-002	Replacement Part	M-30
44-30-020	Replacement Part - Lights	M-30
44-30-031	Waterproof Lights #30 Series	M-30
44305F0317	F2 A-Frame Jack and Coupler	J-7
44305R0317	A-Frame Trailer Coupler	K-12
44305R0500	A-Frame Trailer Coupler	K-12
44311H0301	A-Frame Trailer Coupler	K-12
44314R0303	A-Frame Trailer Coupler	K-12
44-37-031	Waterproof Lights #37 Series	M-31
44-37-032	Waterproof Lights #37 Series	M-31
44-38-031	Waterproof Lights #38 Series	M-32
44-38-032	Waterproof Lights #37 Series	M-32
44-40-004	Fender Mount Lights #40 Series	M-37
45018	Trailer Hitch Extension	B-16
45122	Class V Trailer Hitch Ball Mount	B-11
45123	Class V Trailer Hitch Ball Mount	B-11
45156	Pintle Hook Mounting Plate	B-17
45291	Class V Trailer Hitch Ball Mount	B-11
45292	Trailer Hitch Extension	B-16
45294	Pintle Hook Mounting Plate	B-17
45322	Class V Trailer Hitch Ball Mount	B-11
45323	Class V Trailer Hitch Ball Mount	B-11
45325	Tri-Ball Trailer Hitch Ball Mount	B-11
45519	Class V Trailer Hitch	O-2
4655	Drill Bit	A-9
47-01-001	Replacement Part	M-9
47-01-031	LED Waterproof 4" Round Taillight	M-9
47-06-004	Replacement Part	M-10
47-06-005	LED 6" Oval Mid-Turn Light	M-37
47-06-034	LED Waterproof 6" Oval Mount Taillights	M-10
47-06-404	Replacement Part	M-10
47-106020	Replacement Part	M-25
47-106851	LED Waterproof Clearance Lights	M-26
47-106852	LED Waterproof Clearance Lights	M-26
47-106853	LED Waterproof Clearance Lights	M-25
47-106854	LED Waterproof Clearance Lights	M-25
47-106857	LED Waterproof Clearance Lights	M-26
47-106858	LED Waterproof ID Light Bar	M-39
47-107043	LED Waterproof Side Marker Lights	M-26
47-107044	LED Waterproof Clearance Lights	M-26
47-107046	LED Waterproof Clearance Lights	M-26
47-107047	LED Waterproof Clearance Lights	M-25
47-107048	LED Waterproof Clearance Lights	M-25
47-203667	Grommet Mount Clearance Lights	M-26
47-203668	Grommet Mount Clearance Lights	M-26
47-222012	LED Waterproof Clearance Light	M-24
47-222014	LED Waterproof Clearance Light	M-24
47-222015	LED Waterproof Clearance Light	M-24
47-222017	LED Waterproof Clearance Light	M-24
47-37-001	Replacement Part	M-27, M-39
47-37-002	Replacement Part	M-27
47-37-005	LED Waterproof Lights #37 Series	M-27

PART NO.	DESCRIPTION	PAGE NUMBER
47-37-006	LED Waterproof Lights #37 Series	M-27
47-37-031	LED Waterproof Lights #37 Series	M-27
47-37-032	LED Waterproof Lights #37 Series	M-27
47-37-401	Replacement Part	M-27, M-39
47-37-402	Replacement Part	M-27
47-38-001	Replacement Part	M-28
47-38-002	Replacement Part	M-28
47-38-004	LED Side Marker Lights #38 Series	M-28
47-38-033	LED Side Marker Lights #38 Series	M-28
47-38-034	LED Side Marker Lights #38 Series	M-28
47-38-401	Replacement Part	M-28
47-38-402	Replacement Part	M-28
47-54-001	LED Narrow Taillight #54 Series	M-4
47-54-002	LED ID Light Bar w/ Reflex Lens	M-39
47-54-003	LED ID Light Bar w/ Reflex Lens	M-39
47-58-001	LED Side Marker Lights #58 Series	M-28
47-58-002	LED Side Marker Lights #58 Series	M-28
47-58-031	LED Side Marker Lights #58 Series	M-28
47-58-032	LED Side Marker Lights #58 Series	M-28
47-59-001	LED Side Marker Lights #59 Series	M-29
47-59-002	LED Side Marker Lights #59 Series	M-29
47-59-010	LED Upgrade Kits #59 Series	M-29
47-59-012	LED Upgrade Kits #59 Series	M-29
47-59-401	LED Side Marker Lights #59 Series	M-29
47-59-402	LED Side Marker Lights #59 Series	M-29
47-59-410	LED Upgrade Kits #59 Series	M-29
47-59-412	LED Upgrade Kits #59 Series	M-29
47-84-001	LED Recessed Taillights #84/85 Series	M-6
47-84-005	LED Recessed Taillights #84/85 Series	M-7
47-84-008	LED Recessed Taillights #84/85 Series	M-6
47-84-009	LED Recessed Taillights #84/85 Series	M-7
47-84-026	LED Upgrade Kits #84/85 Series	M-3
47-84-103	LED Long Taillights #84/85 Series	M-5
47-84-104	LED Long Taillights #84/85 Series	M-5
47-84-410	LED Upgrade Kits #84/85 Series	M-3
47-84-412	LED Upgrade Kits #84/85 Series	M-3
47-84-420	Replacement Part	M-4, M-5, M-6, M-7
47-84-527	LED Recessed Taillights #84/85 Series	M-6
47-84-529	LED Recessed Taillights #84/85 Series	M-6
47-84-530	LED Recessed Taillights #84/85 Series	M-7
47-84-540	LED Recessed Taillights #84/85 Series	M-6
47-84-610	LED Surface Mount Taillights	M-5
47-84-711	Incandescent Upgrade Lens #84/85 Series	M-3, M-5, M-6, M-7
47-84-712	Incandescent Upgrade Lens #84/85 Series	M-3, M-5, M-6, M-7
47-84-808	LED Recessed Taillights #84/85 Series	M-6
47-85-002	LED Recessed Taillights #84/85 Series	M-7
47-85-004	LED Recessed Taillights #84/85 Series	M-7
47-85-611	LED Surface Mount Taillights	M-5
47-85-711	Incandescent Upgrade Lens #84/85 Series	M-3
47-86-101	LED Single Taillights #86 Series	M-4
47-86-202	LED Wrap-Around Lights #86 Series	M-30
47-99-004	LED Waterproof ID Light Bar	M-39
47-99-005	LED Waterproof Lights #99 Series	M-27, M-39
47-99-006	LED Waterproof Lights #99 Series	M-27
47-99-034	LED Waterproof ID Light Bar	M-39
47-99-215	LED Waterproof ID Light Bar	M-39
47-99-401	LED Waterproof Lights #99 Series	M-26
47-99-402	LED Waterproof Lights #99 Series	M-26
48-84-008	LED Recessed Taillights #84/85 Series	M-6
48-84-009	LED Recessed Taillights #84/85 Series	M-7
48-84-527	LED Recessed Taillights #84/85 Series	M-6
48-84-711	Incandescent Upgrade Lens #84/85 Series	M-3, M-5, M-6, M-7
48-86-101	LED Single Taillights #86 Series	M-4
48-86-202	LED Wrap-Around Lights #86 Series	M-30
4907	Weld Together Short Side Bracket Kit	A-6
49080	Gooseneck Trailer Hitch	F-6, G-8
49080-024	Gooseneck Trailer Hitch	G-8

PART NO.	DESCRIPTION	PAGE NUMBER
49131†	Trailer Hitch Safety Chain Link	N-18
49132†	Trailer Hitch Safety Chain Link	N-18
49134†	Trailer Hitch Safety Chain Link	N-18
49135†	Trailer Hitch Safety Chain Link	N-18
49137†	Trailer Hitch Safety Chain	N-18
49138†	Trailer Hitch Safety Chain	N-18
49141†	Trailer Hitch Safety Chain	N-18
49147†	Trailer Hitch Safety Chain	N-18
49148†	Trailer Hitch Safety Chain	N-18
49149†	Trailer Hitch Safety Chain	N-18
49150	Trailer Hitch Safety Chain	G-2, H-3
49151	Trailer Hitch Safety Chain	G-2, H-3
4916	Weld Together Long Side Bracket Kit	A-6
49568†	Weight Distributing Kit - Round Bar	E-14
49569†	Weight Distributing Kit - Round Bar	E-14
49570†	Weight Distributing Kit - Round Bar	E-14
49581†	Weight Distributing Kit - Round Bar	E-14
49582†	Weight Distributing Kit - Round Bar	E-14
49583†	Weight Distributing Kit - Round Bar	E-14
49802	License Plate Holder	A-10
49803	Install Hardware	A-10
49901†	Weight Distributing Kit & Sway Control	E-14
49902†	Weight Distributing Kit & Sway Control	E-14
49903†	Weight Distributing Kit & Sway Control	E-14
49904†	Weight Distributing Kit & Sway Control	E-14
49911	Weight Distributing Kit - Round Bar	E-2
49912	Weight Distributing Kit - Round Bar	E-2
49913	Weight Distributing Kit - Round Bar	E-2
5000-DX	Trailer Brake Shoe and Lining Kit	N-7
500103	Pins	J-32
500105	Sidewind Crank Assembly	J-14, J-34
500106	Gear Kits	J-33
500129	Replacement Part	J-7, J-8
500130	Replacement Part	J-8
500131	Replacement Part	J-8
500132	Replacement Part	J-8
500133	Replacement Part	J-8
500134	Replacement Part	J-7, J-8
500135	Replacement Part	J-7, J-8
500136	Replacement Part	J-8
500137	Replacement Part	J-7, J-8
500138	Replacement Part	J-8
500148	Topwind Crank Assembly	J-14, J-34
500153	HD 2-Speed Tandem Landing Gear	J-25
500154	HD 2-Speed Tandem Landing Gear	J-25
500156	Gear Kits	J-33
500161†	Fifth Wheel RV Landing Gear System	J-35
500162	Fifth Wheel RV Landing Gear System	J-5
500171	Sidewind Crank Assembly	J-14, J-34
500177	Pin Kits	J-32
500178	Pin Kits	J-32
500180	Topwind Crank Assembly	J-14, J-34
500187	Powered A-Frame Jack, 3500 lbs.	J-4, 0-4
500188	Powered A-Frame Jack, 3500 lbs.	J-4, 0-4
500190	Replacement Part - Power Trailer Jack	J-3, J-4, J-30
500193	Replacement Part - Power Trailer Jack	J-3
500194	Replacement Part - Power Trailer Jack	J-3
500196	Replacement Part - Power Trailer Jack	J-3
500198	Powered A-Frame Jack, 2500 lbs.	J-5, 0-4
500199	Powered A-Frame Jack, 4000 lbs.	J-3, 0-4
500200	Powered A-Frame Jack, 4000 lbs.	J-3, 0-4
500201	Replacement Part - Power Trailer Jack	J-4
500202	Replacement Part - Power Trailer Jack	J-4
500203	Replacement Part - Power Trailer Jack	J-3, J-4
500204	Replacement Part - Power Trailer Jack	J-5
500205	Trailer Jack Gearbox Cover	J-33
500212	Sidewind Gears	J-33
500217	Replacement Part - Jack	J-33
500219	Lynch Pin Kit	J-32
500223	Bearing Kits	J-33
500224	Bearing Kits	J-33

PART NO.	DESCRIPTION	PAGE NUMBER
500231	Pin Kits	J-32
500232	Pin Kits	J-32
500239	Tube Mounts	J-14, J-31
50024	Fifth Wheel Trailer Hitch Slider	F-7
500241	Trailer Jack Retaining Ring	J-33
500242	Replacement Part - Jack	J-14
500243	Pin Kits	J-32
500244	Trailer Jack Foot	J-14, J-31
500245	Poly Wheels	J-14, J-31
500246	Knob Kits	J-33
500248	Knob Kits	J-33
500250	Replacement Part - Jack	J-33
500251	Bearing Kits	J-33
500256	Sidewind Crank Assembly	J-14, J-34
5002581360	Gear Kits	J-33
500265	Trailer Jack Wheel	J-7
500266	Trailer Jack Wheel	J-7
500267	Trailer Jack Wheel	J-7
500268	Replacement Part	J-7
500270	Drop Legs	J-30
500276	Replacement Part	J-8
500277	Replacement Part	J-8
500282	Trailer Jack Wheel	J-31
500285	Replacement Part	J-24, J-33
500286	Replacement Part	J-10, J-12
500289	Replacement Part - Coupler Repair Kit	K-3, K-4
500293	Replacement Part - Trailer Jack	J-25
500294	Replacement Part - Trailer Jack	J-25
500295	Replacement Part - Trailer Jack	J-24
500296	Replacement Part - Coupler Bolt Kit	K-5
5003	Trailer Brake Shoe and Lining Kit	N-7
500305	Replacement Part - Power Trailer Jack	J-4
500306	Replacement Part - Power Trailer Jack	J-4
500310	Pins	J-32
500312	Replacement Part - Trailer Jack	J-20, J-34
500314	Replacement Part	J-7, J-8
500315	Tube Mounts	J-14, J-31
500320	Jack Accessories	J-8, J-10
500322	Replacement Part - Trailer Jack	J-10
500323	Replacement Part - Trailer Jack	J-10
500324	Replacement Part - Trailer Jack	J-10
500325	Replacement Part - Trailer Jack	J-10
500326	Replacement Part - Trailer Jack	J-32
500329	Trailer Jack Drop Leg	J-30
500330	Replacement Part - Trailer Jack	J-24
500334	Replacement Part - Coupler	K-11
500335	Replacement Part - Coupler	K-11
500336	Replacement Part - Coupler	K-11
500337	Replacement Part - Trailer Jack	J-32
500338	Replacement Part - Trailer Jack	J-32
500339	Tube Mounts	J-31
500340	Replacement Part - Trailer Jack	J-30, J-32
500341	Replacement Part - Trailer Jack	J-32
500344	Replacement Part - Trailer Jack	J-34
500349	Replacement Part	J-10, J-12
500350	Replacement Part - Trailer Winch	L-4
500351	Replacement Part - Trailer Winch	L-4
500353	Replacement Part - Coupler Repair Kit	K-4
500354	Replacement Part - Coupler Cap Spring	K-10
500356	Gooseneck Coupler Locking Pin	K-3, K-4
500357	Replacement Part - Trailer Winch	L-8
500358	Replacement Part - Winch	N-12
500359	Replacement Part - Landing Gear	J-5
500360	Replacement Part - Power Trailer Jack	J-3
500361	Replacement Part - Power Trailer Jack	J-3
500362	Replacement Part - Jacks	J-3, J-4
500363	Replacement Part - Jacks	J-3, J-4
500365	Replacement Part - Trailer Jack	J-6
500366	Replacement Part - Trailer Winch	L-8
500367	Replacement Part - Landing Gear	J-5
500368	Replacement Part - Landing Gear	J-5

PRODUCT INDEX

PART NO.	DESCRIPTION	PAGE NUMBER
500370	Replacement Part - Landing Gear	J-22
500372	Velocity Series High Speed Jack	J-21
500374	Base Plate Kits	J-21
500375	Replacement Part - Trailer	J-21
500376	Replacement Part - Jack Contactor Kit	J-21
500377	Trailer Jack Drop Leg	J-30
500379	High Speed Trailer Jack	J-21
500380	High Speed Trailer Jack	J-21
500382	High Speed Trailer Jack	J-21
500386	High Speed Trailer Jack	J-21
500389	High Speed Trailer Jack	J-21
500400	DC Electric Utility Winch	L-9
500401	DC Electric Utility Winch	L-9
500402	DC Electric Utility Winch	L-9, O-5
500403	DC Electric Heavy Duty Winch	L-10
500404	DC Electric Heavy Duty Winch	L-10
500405	DC Electric Heavy Duty Winch	L-10
500406	DC Electric Heavy Duty Winch	L-10
500407	DC Electric Heavy Duty Winch	L-10
500408	DC Electric Heavy Duty Winch	L-10
500410	DC Electric Hoist	L-11
500411	DC Electric Hoist	L-11
500412	DC Electric Hoist	L-11
500413	Hydraulic Winch	L-11
500414	Hydraulic Winch	L-11
500415	Hydraulic Winch	L-11
500423	DC Electric Heavy Duty Winch	L-10
500424	DC Electric Heavy Duty Winch	L-10
500426	DC Electric Heavy Duty Winch	L-10, O-5
50048	Replacement Part - Fifth Wheel	F-7
500516	Electric Winch Rope	L-12
500517	Trailer Winch Cable	L-12
500520	Electric Winch Rope	L-12
500522	Electric Winch Rope	L-12
500524	Replacement Part - Electric Winch	L-12
500525	Replacement Part - Electric Winch	L-12
500526	Electric Winch Wireless Remote	L-12
500527	Electric Winch Wireless Remote	J-27, L-12
500528	Electric Winch Wired Remote	L-12
500529	Electric Winch Wired Remote	L-12
500530	Electric Winch Wired Remote	L-12
500532	Replacement Part - Electric Winch	L-10
500533	Replacement Part - Electric Winch	L-10
500534	Replacement Part - Electric Winch	L-10
500536	Replacement Part - Electric Winch	L-12
500540	Replacement Part - Electric Winch	L-12
500541	Replacement Part - Electric Winch	L-12
500542	Replacement Part - Electric Winch	L-12
500545	Replacement Part - Electric Winch	L-10, L-11
500546	Replacement Part - Electric Winch	L-10
500549	Electric Winch Accessory - Recovery Damper	L-12
500553	Electric Winch Quick Mount	L-12
500554	Electric Winch Accessory Kit	L-12
500600	DC Electric Heavy Duty Winch	L-9
500601	DC Electric Heavy Duty Winch	L-9
500602	Electric Winch Snatch Block	L-12
500603	Electric Winch Snatch Block	L-12
500604	Electric Winch Clevis	L-12
500605	Electric Winch Clevis	L-12
500606	Electric Winch Connector	L-12
500607	Electric Winch Connector	L-12
500608	Trailer Winch Cable	L-12
500609	Trailer Winch Cable	L-12
500620	XLT Powered Winch	L-2
500621	XLT Powered Winch	L-2
500630	DC Electric Utility Winch	L-9, O-5
500631	DC Electric Utility Winch	L-9
500632	DC Electric Utility Winch	L-9
500701†	Powered A-Frame Jack, 4000 lbs.	J-35
500702†	Powered A-Frame Jack, 4000 lbs.	J-35

PART NO.	DESCRIPTION	PAGE NUMBER
500703†	Powered A-Frame Jack, 3500 lbs.	J-35
500704†	Powered A-Frame Jack, 3500 lbs.	J-35
500705	Replacement Part - Dampener	K-11
500708	Single Output Fifth Wheel RV Landing Gear	J-5
5010	Trailer Brake Shoe and Lining Kit	N-7
501001	Rope Keeper	L-7
501101	Trailer Winch Handle	L-5, L-7
501103	Trailer Winch Handle	L-5
501106	Trailer Winch Handle	L-5
501107	Trailer Winch Handle	L-5
501108	Trailer Winch Handle	L-5, L-6
501109	Trailer Winch Handle	L-5
501110	Trailer Winch Handle	L-6
501115	Replacement Part - Trailer Winch	L-7
501117	Replacement Part - Trailer Winch	L-7
501118	Replacement Part - Trailer Winch	L-7
501121	Replacement Part - Trailer Winch	L-7
501122	Replacement Part - Trailer Winch	L-7
501124	Replacement Part - Trailer Winch	L-7
501125	Replacement Part - Trailer Winch	L-7
501130	Replacement Part - Trailer Winch	L-7
501131	Replacement Part - Trailer Winch	L-7
501132	Replacement Part - Trailer Winch	L-6
501133	Replacement Part - Trailer Winch	L-6
501134	Replacement Part	L-6
501135	Replacement Part	L-4, L-6
501136	Replacement Part - Trailer Winch	L-4
501137	Replacement Part - Trailer Winch	L-4
501138	Replacement Part - Trailer Winch	L-4
501202	Trailer Winch Strap	L-5, L-6
501207	Trailer Winch Strap	L-5, L-6
501210	Replacement Part - Trailer Winch	L-6
50223	Fifth Wheel Trailer Hitch Chain Bracket	F-8
50-57-007	7-Way Connector - Trailer End	C-17
50-57-503	7-Way Connector - Vehicle End	C-17
50-61-008	6-Way Connector Harness - Trailer End	C-16
50-61-104	6-Way Connector Harness - Trailer End	C-16
50-61-106	6-Way Connector Harness - Trailer End	C-16
50-61-108	6-Way Connector Harness - Trailer End	C-16
50-67-001	7-Way Connector Harness - Trailer End	C-19
50-67-002	7-Way Connector Harness - Trailer End	C-19
50-67-003	7-Way Connector Harness - Trailer End	C-19
50-67-004	7-Way Connector Harness - Trailer End	C-19
50-67-005	7-Way Connector Harness - Trailer End	C-19
50-67-007	7-Way Connector Harness - Trailer End	C-19
50-67-103	7-Way Connector Harness - Trailer End	C-19
50-67-106	7-Way Connector Harness - Trailer End	C-19
50-67-210	7-Way Connector Harness - Trailer End	C-18
50-67-410	7-Way Connector Harness - Trailer End	C-18
50-67-614	7-Way Connector Harness - Trailer End	C-20, C-24
50-67-616	7-Way Connector Harness - Trailer End	C-20, C-24
50-67-618	7-Way Connector Harness - Trailer End	C-20, C-24
50-67-620	7-Way Connector Harness - Trailer End	C-20, C-24
50-67-901	7-Way Connector Harness - Trailer End	C-18
50-67-907	7-Way Connector Harness - Trailer End	C-19
50-767751	LED Waterproof Flange Mount Stop Lights	M-10
50-767752	LED Waterproof Flange Mount Stop Lights	M-10
50-77-001	7-Way Connector - Vehicle End	C-17
50-77-003	7-Way Connector - Trailer End	C-17
50-77-070	Towing Electrical Mount Bracket (2 of 2)	C-28
50-77-071	Towing Electrical Mount Bracket (2 of 2)	C-28
50-85-002	Breakaway Switch	N-4
50-85-007	Breakaway Switch	N-4
50-85-104	Breakaway Charger	N-5
5085115	Post Mount Bracket Kit	N-2, N-4
50-85-302	Breakaway System	N-4
50-85-312	Breakaway System	N-4
50-85-313	Breakaway System	N-2
50-85-315	Breakaway System	N-2
50-85-320	Breakaway System	N-2
50-85-325	Breakaway System	N-2

PART NO.	DESCRIPTION	PAGE NUMBER
508573	Trailer Fender	N-11
508574	Trailer Fender	N-11
50-86-004	6-Way Connector Harness - Vehicle End	C-16
50-86-007	6-Way Connector Harness - Vehicle End	C-16
50-87-002	7-Way Connector Harness - Vehicle End	C-18
50-87-004	7-Way Connector Harness - Vehicle End	C-18
50-87-007	7-Way Connector Harness - Vehicle End	C-18
50-87-009	7-Way Connector Harness - Vehicle End	C-18
50-97-407	7-Way Fifth Wheel Adapter Harness	C-21
50-97-410	7-Way Fifth Wheel Adapter Harness	C-22
50-97-411	7-Way Fifth Wheel Adapter Harness	C-22
50-97-412	7-Way Fifth Wheel Adapter Harness	C-22
50-98-003	Towing Electrical Plug Holder	C-29
50-98-050	Trailer Connector Adapter - 7 to 4-Flat	C-26
50-98-051	Trailer Connector Adapter - 7 to 6-Way	C-26
50-98-052	Trailer Connector Adapter - 7 to 4-Flat	C-26
50-98-054	Trailer Connector Adapter - 6 to 4-Flat	C-26
5100	Trailer Brake Control - Timed	D-5
5101-HA	Trailer Brake Magnet Kit	N-8
5106	Trailer Brake Magnet Kit	N-8
5109	Trailer Brake Magnet Kit	N-8
5113	Trailer Brake Magnet Kit	N-8
5114	Trailer Brake Magnet Kit	N-8
51-20036	Trailer Connector Adapter - 4 to 5-Flat	C-26
5120TEK	Trailer Brake Magnet Retaining Ring	N-8
5121TEK	Trailer Brake Magnet Retaining Clip	N-8
5122	Trailer Brake Wire Clip	N-8
51-67-003	7-Way Connector Harness - Trailer End	C-19
51-87-002	7-Way Connector Harness - Vehicle End	C-18
51-87-004†	7-Way Connector Harness - Vehicle End	C-34
52 0801	Replacement Part - Coupler Repair Kit	K-12
5280	Trailer Brake Control Mounting Kit	D-7
5298	Trailer Brake Control Mounting Kit	D-7
5305	Trailer Brake Return Spring	N-7
5307	Trailer Brake Return Spring	N-7
5330†	Trailer Hitch Tube Cover	B-29
5350	Motorhome Hitch	A-8
5351†	Trailer Hitch Tube Cover	B-29
5352†	Trailer Hitch Tube Cover	B-29
5353	Trailer Brake Hold Down Kit	N-7
5362	Trailer Hitch Tube Cover	B-24
5363	Trailer Hitch Tube Cover	B-24
54000-026	4-Flat Connector Harness - Trailer End	C-14
54000-027	5-Flat Connector Harness - Trailer End	C-14
54001	Replacement Part	M-19, M-21
54002	Replacement Part	M-21
54003	Replacement Part	M-19
54003-017	4-Way Ag Connector Harness	C-25
54003-018	4-Way Ag Connector Harness	C-25
54003-020†	4-Way Ag Connector Harness	C-34
54003-040	Economy Ag LED Light Kit	M-48
54003-041	Ag Transport LED Light Kit	M-48
54003-137	Economy Ag LED Pedestal Mount Light Kit	M-48
54003-138	Ag Transport LED Light Kit	M-48
54004	Red Stop/Tail/Turn Light	M-10
54005	LED Oval Courtesy Light Clear	M-24
54006	Red Stop/Tail/Turn Light	M-11
54006-009	7-Way Connector Harness - Trailer End	C-20
54006-010	7-Way Connector Harness - Trailer End	C-20
54006-015	7-Way Connector Harness - Trailer End	C-20
54006-016	7-Way Connector Harness - Trailer End	C-20
54006-043	7-Way Connector Harness - Trailer End	C-19
54006-044	7-Way Connector Harness - Trailer End	C-19
54006-045	7-Way Connector Harness - Trailer End	C-19
54006-046	7-Way Connector Harness - Trailer End	C-19
54006-049	7-Way Connector Harness - Trailer End	C-19
54006-050	7-Way Connector Harness - Trailer End	C-19
54006-051	7-Way Connector Harness - Trailer End	C-19
54006-052	7-Way Connector Harness - Trailer End	C-19
54006-057	7-Way Connector Harness - Trailer End	C-20
54006-058	7-Way Connector Harness - Trailer End	C-20

PART NO.	DESCRIPTION	PAGE NUMBER
54006-059	7-Way Connector Harness - Trailer End	C-20
5404	Trailer Brake Adjusting Hardware	N-7
54200-012	LED 4" Round Taillight	M-9
54200-013	LED 4" Round Taillight	M-9
54200-015	Narrow LED Tail Lamp	M-4
54200-016	Chrome Bezel	M-4
54200-018	LED 4" Round Taillight	M-9
54-20012	Towing Electrical Mount Bracket	C-28
54201-001	Waterproof LED Clearance Lights	M-25
54201-002	Waterproof LED Clearance Lights	M-25
54201-006	Hi Intensity Micro LED Light	M-25
54201-007	Hi Intensity Micro LED Light	M-25
54201-008	Hi Intensity Micro LED Light	M-25
54201-010†	Incandescent Lights #58 Series	M-33
54201-011	Incandescent Lights #58 Series	M-25
54201-013	Incandescent Lights #58 Series	M-25
54201-014	Incandescent Lights #58 Series	M-25
54201-015	2.5" Round LED Red Clearance Light	M-29
54201-016	2.5" Round LED Red Clearance Light	M-29
54201-017	2.5" Round LED Amber Clearance Light	M-29
54201-018	2.5" Round LED Amber Clearance Light	M-29
54205-010	LED Light Strip	M-38
54205-011	LED Light Strip	M-38
54205-012	LED Light Strip	M-38
54205-013	LED Light Strip	M-38
54205-014	LED Light Strip	M-38
54205-015	LED Light Strip	M-38
54205-016	LED Light Strip	M-38
54205-017	LED Light Strip	M-38
54205-018	LED Light Strip	M-38
54205-019	LED Light Strip	M-38
54205-020	LED Strobe Light	M-38
54205-021	LED Strobe Light	M-38
54205-022	LED Strobe Light	M-38
54205-023	LED Strobe Light	M-38
54205-024	LED Strobe Light	M-38
54206-001	License Plate Lights	M-41
54209-001	Auxiliary LED Work Light	M-12, M-49
54209-002	Auxiliary LED Work Light	M-12, M-49
54209-005	Replacement Part - Ag	M-47
54209-006	Replacement Part - Ag	M-47, M-48
54209-007	Replacement Part - Ag	M-47
54209-008	Heavy-Duty Ag LED Lights	M-47, M-48
54209-009	Replacement Part - Ag	M-47
54209-010	Heavy-Duty Ag LED Lights	M-47
54209-011	Replacement Part - Ag	M-47
54209-012	Heavy-Duty Ag LED Lights	M-47
54209-013	Replacement Part - Ag	M-47
54209-014	Replacement Part - Ag	M-47
54209-015	Replacement Part - Ag	M-47
54209-016	Replacement Part - Ag	M-47
54209-017	Auxiliary LED Work Light	M-12, M-49
54209-018	Auxiliary LED Work Light	M-12, M-49
54209-019	Replacement Part - Ag	M-47
54209-020	Heavy-Duty Ag LED Lights	M-47, M-48
54209-021	Replacement Part - Ag	M-47
54209-022	Heavy-Duty Ag LED Lights	M-47, M-48
54209-025	Auxiliary LED Work Light	M-12, M-49
54209-031	Pedestal Mount AG LED Light	M-48
54209-032	Pedestal Mount AG LED Light	M-48
54209-047	Pedestal Mount AG LED Light	M-48
54209-048	Pedestal Mount AG LED Light	M-48
5443	License Plate Holder	A-10
54500-001	Ag Light Enhanced Lighting Modules	C-25
54500-002	Ag Light Enhanced Lighting Modules	C-25
54504-001	Protective Tail Light Bracket	M-8, M-9, M-11, M-12, M-17, M-18
54-57-007	7-Way Connector - Trailer End	C-17
54-57-503	7-Way Connector - Vehicle End	C-17
54-6562†	Trailer Wire Emulator	C-34
54-67-525	7-Way Connector Harness - Trailer End	C-19

PRODUCT INDEX

PART NO.	DESCRIPTION	PAGE NUMBER
54700-003	7-Way Fifth Wheel Adapter Harness	C-22
54700-004	7-Way Fifth Wheel Adapter Harness	C-22
54700-007	7-Way Fifth Wheel Adapter Harness	C-22
54700-009	7-Way Fifth Wheel Adapter Harness	C-22
54700-010	Screw Kit for Aluminum Beds	C-21
54-77-001	7-Way Connector - Vehicle End	C-17
54-77-003	7-Way Connector - Trailer End	C-17
54-77-071	Towing Electrical Mount Bracket (2 of 2)	C-28
54801-001	Trailer Brake Assembly - Right Hand 10"	N-6
54801-002	Trailer Brake Assembly - Left Hand 10"	N-6
54801-003	Trailer Brake Assembly - Right Hand 12"	N-6
54801-004	Trailer Brake Assembly - Left Hand 12"	N-6
54801-005	Trailer Brake Assembly - Right Hand 10"	N-6
54801-006	Trailer Brake Assembly - Left Hand 10"	N-6
54801-007	Trailer Brake Assembly - Right Hand 12"	N-6
54801-008	Trailer Brake Assembly - Left Hand 12"	N-6
54801-023	Trailer Brake Assembly - Right Hand 10"	N-6
54801-024	Trailer Brake Assembly - Left Hand 10"	N-6
54801-025	Trailer Brake Assembly - Right Hand 12"	N-6
54801-026	Trailer Brake Assembly - Left Hand 12"	N-6
5481	Wire Forms	A-10
5482	Wire Forms	A-10
54-85-002	Breakaway Switch	N-4
54-85-007	Breakaway Switch	N-4
54970	Weight Distributing Shank	E-7, E-10, E-12
54976†	Weight Distributing Shank	E-14
54977†	Weight Distributing Shank	E-11, E-14
54980	Replacement Part - WD	E-8
54-98-004	Battery Isolation Solenoid	C-31
54-98-050	Trailer Connector Adapter - 7 to 4-Flat	C-26
54-98-051	Trailer Connector Adapter - 7 to 6-Way	C-26
54-98-052	Trailer Connector Adapter - 7 to 4-Flat	C-26
54994	Replacement Part - WD	E-8
54998	Weight Distributing Shank	E-7
55003	Trailer Hitch Coupler Lock	B-23
55010	Trailer Hitch Pin	E-10, E-11, E-12, B-20
5502	Wheel Bearing Sets	N-7, N-9
5503	Wheel Bearing Sets	N-8, N-9
55030	Replacement Part - WD	E-12
5504	Trailer Brake Control - Timed	D-5
5505	Wheel Bearing Sets	N-7, N-9
55055	Replacement Part - Fifth Wheel	F-18
5507	Wheel Bearing Sets	N-7, N-9
5508	Wheel Bearing Sets	N-7, N-9
5509	Wheel Bearing Sets	N-7, N-9
55180	Replacement Part - WD	E-10, E-11, E-12
5535	Trailer Brake Control - Proportional	D-4
55392	Pull Wire	A-10
55393	Pull Wire	A-10
55478	Replacement Part - Fifth Wheel	F-16
55515†	Trailer Hitch Clip	B-28, E-10, E-11, E-12, E-13
55630	Replacement Part - WD	E-10, E-11
5592	Trailer Hitch Safety Chain	N-13
5602	Wheel Grease Seal	N-8
5603	Wheel Grease Seal	N-8
5604	Wheel Grease Seal	N-8
5605	Wheel Grease Seal	N-8
5606	Wheel Grease Seal	N-8
5607	Wheel Grease Seal	N-8
5608	Wheel Grease Seal	N-8
5651	Wheel Grease Seal	N-8
5652	Wheel Grease Seal	N-8
5691	Trailer Hitch Receiver Tube	A-9
5692	Trailer Hitch Receiver Tube	A-9
5720	Trailer Brake Mounting Bolt	N-9
5721	Trailer Brake Mounting Bolt	N-9
5762	Clevis Ball Mount	B-20
5764†	Clevis Mount Pin	B-29
5774	Trailer Brake Spindle Nut Kit	N-9

PART NO.	DESCRIPTION	PAGE NUMBER
5775	Trailer Brake Spindle Nut Kit	N-9
5780	Trailer Tongue Weight Scale	E-8
5780TEK	Trailer Brake Wheel Hardware	N-9
5787	Trailer Brake Wheel Hardware	N-9
58024	Replacement Part - WD	E-10
58032	Replacement Part - WD	E-10, E-11
58033	Replacement Part - WD	E-10, E-13
580400	Trailer Hitch Towing Lock	B-22
580401	Trailer Hitch Towing Lock	B-22
580402	Trailer Hitch Towing Lock	B-22
580403	Trailer Coupler Lock	B-22
580404	Trailer Coupler Lock Set	B-22
580405	Trailer Hitch Towing Lock	B-22
580406	Trailer Coupler Lock Set	B-22
580407	Trailer Hitch Towing Lock	B-22
580408	Trailer Coupler Lock	B-22
580409	Trailer Coupler Lock	B-22
580410	Trailer Coupler Lock	B-22
580412	Trailer Hitch Towing Lock	B-23
58053	Replacement Part - Fifth Wheel	F-16, F-17
58054	Replacement Part - Fifth Wheel	F-16, F-17
58055	Replacement Part - Fifth Wheel	F-16, F-17
58056	Replacement Part - Fifth Wheel	F-16, F-17
58058	Fifth Wheel Trailer Hitch Rails	F-9, F-12, F-18
58060	Replacement Part - WD	E-7, E-13
58062	Replacement Part - WD	E-7, E-13
58070†	Trailer Hitch Tube Cover	B-29
58079	Gooseneck Trailer Hitch	F-6, G-8
58089	Replacement Part - Fifth Wheel	F-16
58093	Fifth Wheel Trailer Hitch Lock Links	F-7
58094	Replacement Part - Fifth Wheel	F-16, F-17
58097	Replacement Part - WD	E-11
58098	Replacement Part - WD	E-11
58099	Replacement Part - Fifth Wheel	F-17
58102	Trailer Hitch Ball Reducer Bushing	B-15
58109	Trailer Hitch Ball Reducer Bushing	B-24
58112	Replacement Part - WD	E-10, E-12
58114	Replacement Part - WD	E-10, E-12
58115	Replacement Part - WD	E-10, E-12
58117	Trailer Hitch Ball Grease	B-24
58133	Replacement Part - WD	E-11
58146	Replacement Part - Fifth Wheel	F-3, F-16
58147	Replacement Part - Fifth Wheel	F-3, F-16
58161	Replacement Part - Fifth Wheel	F-7
58162	Replacement Part - WD	E-8, E-10, E-11, E-12
58164	Replacement Part - Fifth Wheel	F-18
58166	Fifth Wheel Trailer Hitch Spacer Kit	F-18
58167	Replacement Part - WD	E-10
58184	Trailer Hitch Ball Reducer Bushing	E-10, E-11, E-12, B-24
58192	Replacement Part - WD	E-13
58208	Fifth Wheel Trailer Hitch Adapter Kit	F-6, G-8
58215	Replacement Part - Fifth Wheel	F-13, F-14, F-15
58216	Replacement Part - Fifth Wheel	F-13, F-14, F-15
58225	Replacement Part - Fifth Wheel	F-13
58229	Replacement Part - Fifth Wheel	F-13, F-14, F-15
58230	Replacement Part - Fifth Wheel	F-13, F-14, F-15
58240	Replacement Part - Fifth Wheel	F-13, F-14, F-15
58255†	Replacement Part - Fifth Wheel	F-13
58276	Replacement Part - Fifth Wheel	F-13, F-14
58293	Replacement Part - Fifth Wheel	F-15
58296	Replacement Part - Fifth Wheel	F-15
58305	Weight Distributing Chain Hangers	E-8
58306	Weight Distributing Chain Hangers	E-8
58312	Replacement Part - Gooseneck	G-9
58314	Replacement Part - Fifth Wheel	F-9, F-18
58321	Replacement Part - Gooseneck	G-9
58333	Replacement Part - WD	E-12
58336	Replacement Part - WD	E-12
58337	Replacement Part - WD	E-12

PART NO.	DESCRIPTION	PAGE NUMBER
58338	Replacement Part - WD	E-12
58339	Replacement Part - WD	E-12
58362	Replacement Part - WD	E-12
58364	Replacement Part - WD	E-12
58369	Replacement Part - WD	E-11
58374†	Hitch End Cap	A-143
58381	Hole Saw	A-9, G-7
58384	Gooseneck Trailer Hitch Template	G-7
58388	Trailer Hitch Pin and Clip	B-15, B-20
58389	Replacement Part - Gooseneck	G-9
58392	Replacement Part - WD	E-8, E-10, E-11
58393	Pole Tongue Adapter	E-7
58419	Replacement Part - Fifth Wheel	F-6, F-13, F-14, G-8
58430	Replacement Part - Fifth Wheel	F-9
58431	Trailer Hitch Ball Reducer Bushing	B-15
58435	Replacement Part - WD	E-13
58437	Replacement Part - WD	E-13
58438	Replacement Part - Gooseneck	F-5, G-4
58439	Replacement Part - WD	E-12
58440	Replacement Part - WD	E-12
58441	Replacement Part - WD	E-12
58442	Replacement Part - WD	E-12
58444	Replacement Part - WD	E-12
58459	Replacement Part - WD	E-11
58467	Replacement Part - Fifth Wheel	F-9, F-10
58468	Replacement Part - Gooseneck	G-4
58472	Replacement Part - Fifth Wheel	F-4
58473	Replacement Part - Fifth Wheel	F-4
58474	Replacement Part - Fifth Wheel	F-4
58475	Replacement Part - Fifth Wheel	F-4
58484	Replacement Part - Fifth Wheel	F-3, F-16
58493	Replacement Part - Slider Handle	F-7
58497	Replacement Part - WD	E-9
58498	Replacement Part - WD	E-9
58499	Replacement Part - WD	E-9
58500	Replacement Part - WD	E-9
58501	Replacement Part - WD	E-9
58503	Fifth Wheel Trailer Hitch Adapter Kit	F-9, F-10
58504	Replacement Part - Fifth Wheel	F-10
58507	Sway Control Rivet Nuts	E-6
58513	Replacement Part - WD	E-9
58514	Replacement Part - Fifth Wheel	F-13, F-14
58521	Replacement Part - Fifth Wheel	F-3, F-16
58524	Replacement Part - Gooseneck	G-9
58527	Replacement Part - WD	E-9
58528	Replacement Part - WD	E-9
58530	Rubber Bolt Cap	A-10
58541	Replacement Part - Fifth Wheel	F-14
58542	Replacement Part - Fifth Wheel	F-14
58543	Replacement Part - Fifth Wheel	F-16
58550	Ball Mount Reducer Sleeve	B-15
58552	Ball Mount Reducer Sleeve	B-15
58553	Replacement Part - Fifth Wheel	F-2
58563	Accessory Part - Fifth Wheel	F-2
59000	Vehicle Interior Organizer	I-13
5901TEK	Trailer Brake Control Mounting Kit	D-7
5904	Trailer Brake Control Mounting Kit	D-7
59043	Roof Top Cargo Carrier	I-4
5906	Replacement Part - Brake Control Bracket	D-7
59100†	Cargo Carrier Bag	I-16
59102	Cargo Carrier Bag	I-7
59108†	Cargo Carrier - Trailer Hitch Mount	I-16
59109	Cargo Carrier - Trailer Hitch Mount	I-5
59110†	Cargo Carrier - Trailer Hitch Mount	I-16
59119	Cargo Carrier Bag	I-7
59200	Cargo Net	I-13
59300	Replacement Part - Water Craft Carrier	I-9
59302	Replacement Part - Water Craft Carrier	I-9
59303	Replacement Part - Water Craft Carrier	I-9
59305†	Ratchet Tie Down Strap	I-17
59306†	Ratchet Tie Down Strap	I-16

PART NO.	DESCRIPTION	PAGE NUMBER
59307	Bike Carrier - Trailer Hitch Mount	I-8
59308	Bike Carrier - Trailer Hitch Mount	I-8
59310	Bike Carrier - Trailer Hitch Mount	I-8
59315†	Roof Rack Lock Core System	I-3, I-17
59316†	Roof Rack Lock Core System	I-3, I-17
59318†	Cargo Carrier Bag	I-16
59400	2 Bike Carrier - Trailer Hitch Mount	I-8
59401	4 Bike Carrier - Trailer Hitch Mount	I-8
59403†	3 Bike Carrier - Trailer Hitch Mount	I-16
59405	Replacement Part - Bike Carrier	I-8
59406	Replacement Part - Bike Carrier	I-8
59407	Replacement Part - Bike Carrier	I-8
59502	Cargo Carrier - Trailer Hitch Mount	I-5
59504	Roof Top Cargo Carrier	I-3
59505	Roof Top Cargo Carrier	I-3
59507	Cargo Carrier - Trailer Hitch Mount	I-5
59510	Replacement Part - Cargo Carrier	I-5
59516	Cargo Carrier Light Kit	I-13
59550	Cargo Carrier - Trailer Hitch Mount	I-5
59622	Universal Van Rack	I-9
59623	Universal Van Rack	I-9
5973	Replacement Part - Gooseneck	G-9
59742	Truck Bed Rack	I-10
59794	Truck Bed Load Stop Kit	I-10
59796	Truck Bed Eye Bolt Kit	I-10
59799	Truck Bed Rack	I-10
5983	Replacement Part - Gooseneck	G-9
59904	Bike Mounting Adapter Kit	I-13
59913	Water Craft Carrier - Roof Rack	I-9
59970†	Vehicle Roof Rack	I-17
59972 †	Vehicle Roof Rack	I-17
59976†	Vehicle Roof Rack	I-17
5AB-E1621-16K	Fifth Wheel Coupler	H-4, O-3
5AB-E1621-610	Fifth Wheel Coupler	H-4
5AB-E510-710	Fifth Wheel Coupler	H-4
5AB-S500-700	Fifth Wheel Coupler	H-4
5AS16K	Fifth Wheel Coupler	H-5
600051	Point of Purchase Display	O-4
60037	Trailer Hitch Tube Cover	B-24
60037-024†	Trailer Hitch Tube Cover	B-29
6004	Trailer Brake Shoe and Lining Kit	N-7
6005	Trailer Brake Shoe and Lining Kit	N-7
6011	Fifth Wheel Trailer Hitch Lube Plate	F-8
6020	Replacement Part - Fifth Wheel	F-17
60-50-001	Mounting Bracket	M-41
61009†	Weight Distributing Kit - Round Bar	E-14, E-14
610322	Tubular Swivel Jack	J-11
6106	Trailer Brake Magnet Kit	N-8
6109	Trailer Brake Magnet Kit	N-8
61300	Fifth Wheel Turret	H-5
61301†	Fifth Wheel Coupler Spacer Kit	G-2, H-3, H-5, H-7
61302	Fifth Wheel Turret	H-5
61410†	Fifth Wheel Coupler	H-7
61411†	Fifth Wheel Coupler	H-7
61412	Fifth Wheel Coupler	H-5
61420†	Fifth Wheel Coupler	O-3, H-7
61421†	Fifth Wheel Coupler	H-7
61422	Fifth Wheel Coupler	H-5, O-3
61450†	Fifth Wheel Coupler	H-7
61452	Fifth Wheel Coupler	H-5
62	6-Way Connector - Vehicle End	C-16
6201	Clevis Ball Mount	B-20
63	6-Way Connector - Trailer End	C-16
6300	Gooseneck Trailer Hitch Head	G-6
63010	Pintle Hook Combination	B-18
63011	Pintle Hook Combination	B-18
63012	Pintle Hook Combination	B-18
63013	Pintle Hook	B-18
63014	Pintle Hook	B-18
63015	Pintle Hook	B-18

PRODUCT INDEX

PART NO.	DESCRIPTION	PAGE NUMBER
63016	Pintle Hook	B-18
63017	Replacement Part - Pintle Hook Ball	B-18
63018	Replacement Part - Pintle Hook Ball	B-18
63019	Replacement Part - Pintle Hook Ball	B-18
63020	Replacement Part - Pintle Chain Assy	B-18
63022	Lunette Ring	K-7
63023	Lunette Ring	K-7
63024	Forged D-Ring	N-13
63025	Forged D-Ring	N-13
63026	Forged D-Ring	N-13
63027	Forged D-Ring	N-13
63028	Forged D-Ring	N-13
63029†	Tow Hook	N-18
63030†	Tow Hook	N-18
63032	Pintle Hook Mounting Plate Hardware	B-18
63033	Replacement Part - Lunette Hardware	K-7
63034	Trailer Hitch Safety Chain	N-13
63035	Trailer Hitch Safety Chain	N-13
63036	Lunette Ring	K-7
63040	Pintle Hook Combination	B-19
63041	Pintle Hook Combination	B-19
63042	Pintle Hook Combination	B-19
63043	Pintle Hook	B-19
63044	Trailer Hitch Tow Hook	B-19
63045	Tow Strap Mount	B-19
63046	Tow Strap Loop	B-19
63047†	Trailer Hitch Tow Hook	B-27
63050	Replacement Part - Pintle Hook Ball	B-18
63051	Replacement Part - Pintle Hook Ball	B-18
63052	Replacement Part - Pintle Hook Ball	B-18
63056	Pintle Hook Mounting Plate	B-17
63057	Pintle Hook Mounting Plate	B-17
63058	Pintle Hook Mounting Plate	B-17
63059	Pintle Hook Mounting Plate	B-17
63060	Lunette Ring	K-7
63069	Trailer Hitch Pin and Clip	B-13, B-23
63070	Trailer Hitch Pin and Clip	B-13
63071	Trailer Hitch Pin and Clip	B-13
63072	Pintle Trailer Hitch Mount	B-14, B-17
63075	Tri-Ball Trailer Hitch Ball Mount	B-13
63076	Dual-Ball Trailer Hitch Ball Mount	B-13
6308	Replacement Part - Gooseneck	G-9
63080	Trailer Hitch Anti Rattle Device	B-21
63082	Trailer Hitch Anti Rattle Device	B-21
63089	Trailer Hitch Ball Mount Bag	B-20
63090	Trailer Hitch Anti Rattle Device	B-21
63091	Trailer Hitch Anti Rattle Device	B-21
63100	Trailer Hitch Anti Rattle Device	B-21
63100-025†	Trailer Hitch Anti Rattle Device	B-29
63120†	2 Bike Carrier - Trailer Hitch Mount	I-16
63123†	3 Bike Carrier - Trailer Hitch Mount	I-16
63124†	4 Bike Carrier - Trailer Hitch Mount	I-16
63134	2 Bike Carrier - Trailer Hitch Mount	I-7
63135	Replacement Part - Bike Carrier	I-7
63138	4 Bike Carrier - Trailer Hitch Mount	I-7
63148†	Replacement Part - Bike Carrier	I-16
63153	Cargo Carrier - Trailer Hitch Mount	I-6
63155	Cargo Carrier - Trailer Hitch Mount	I-6
63180	Tow Bar - Adjustable	N-14
63181	Tow Bar - Adjustable	N-14
63201	Trailer Hitch Anti Rattle Device	B-21
63202†	Trailer Hitch Pin and Clip	B-28
63203	Trailer Hitch Pin and Clip	B-20
63204	Trailer Hitch Pin and Clip	B-20
63205	Trailer Hitch Pin and Clip	B-20
63216KA†	Trailer Coupler Lock Set	B-28
63218KA†	Trailer Coupler Lock Set	B-28
63219KA†	Trailer Coupler Lock Set	B-28
63220KA†	Trailer Coupler Lock Set	B-28
63221KA†	Trailer Coupler Lock Set	B-28
63222KA†	Trailer Coupler Lock Set	B-28

PART NO.	DESCRIPTION	PAGE NUMBER
63223	Trailer Hitch Towing Lock	B-22
63224	Trailer Hitch Towing Lock	B-22
63225	Trailer Coupler Lock	B-23
63227	Trailer Coupler Lock	B-23
63228	Trailer Coupler Lock	B-23
63233†	Cable Lock	B-28
63240	Trailer Hitch Pin and Clip	B-20
63241	Trailer Hitch Pin and Clip	B-20
63242	Trailer Hitch Pin and Clip	B-20
63243	Trailer Hitch Pin and Clip	B-20
63248	Trailer Hitch Towing Lock	B-22
63250†	Trailer Coupler Lock Set	B-28
63251	Fifth Wheel Trailer Hitch King Pin Lock	F-8
63252	Trailer Hitch Towing Lock	B-22
63253	Trailer Hitch Towing Lock	B-22
63254	Fifth Wheel Trailer Hitch Lock	F-8
63255	Cable Lock	B-23
63256	Trailer Hitch Towing Lock	B-23
63258	Trailer Hitch Pin and Clip	B-20
63259	Trailer Hitch Towing Lock	B-23
63260	Trailer Hitch Towing Lock	B-23
63300	Trailer Hitch Alignment System	B-24, N-16
63451	Trailer Hitch Safety Chain	N-13
63451†	Fifth Wheel Trailer Hitch King Pin Lock	B-28
63604	Cargo Carrier Bag	I-6
63801†	Class III Trailer Hitch Ball	B-28
63802	Class IV Trailer Hitch Ball	B-5
63803	Class IV Trailer Hitch Ball	B-5
63804†	Class IV Trailer Hitch Ball	B-28
63805†	Replacement Part - Hitch Ball	B-28
63806†	Replacement Part - Hitch Ball	B-28
63807†	Replacement Part - Hitch Ball	B-28
63808†	Replacement Part - Hitch Ball Shank	B-28
63809†	Replacement Part - Hitch Ball Shank	B-28
63810	Class I Trailer Hitch Ball	B-3
63810-006†	Class I Trailer Hitch Ball	B-25
63811†	Class I Trailer Hitch Ball	B-25
63812	Class I Trailer Hitch Ball	B-3
63813†	Class I Trailer Hitch Ball	B-25
63814	Class I Trailer Hitch Ball	B-3
63816	Class I Trailer Hitch Ball	B-3
63816-006†	Class I Trailer Hitch Ball	B-25
63817†	Class I Trailer Hitch Ball	B-25
63818†	Class I Trailer Hitch Ball	B-25
63819†	Class I Trailer Hitch Ball	B-25
63820	Class II Trailer Hitch Ball	B-4
63821†	Class II Trailer Hitch Ball	B-25
63822	Class II Trailer Hitch Ball	B-4
63823†	Class II Trailer Hitch Ball	B-25
63824	Class II Trailer Hitch Ball	B-4
63830	Class IV Trailer Hitch Ball	B-4
63831†	Class IV Trailer Hitch Ball	B-25
63834	Class V Trailer Hitch Ball	B-4
63835	Class V Trailer Hitch Ball	O-2
63835†	Class V Trailer Hitch Ball	B-25
63836	Class V Trailer Hitch Ball	B-4
63840	Class V Trailer Hitch Ball	B-4
63845	Class IV Trailer Hitch Ball	B-4
63845-006†	Class IV Trailer Hitch Ball	B-25
63846†	Class IV Trailer Hitch Ball	B-25
63847	Class IV Trailer Hitch Ball	B-4
63847-006†	Class IV Trailer Hitch Ball	B-25
63848†	Class IV Trailer Hitch Ball	B-25
63849	Class IV Trailer Hitch Ball	B-4
63850†	Class IV Trailer Hitch Ball	B-25
63851	Class I Trailer Hitch Ball	B-3
63852	Class IV Trailer Hitch Ball	B-4, B-5
63853	Class IV Trailer Hitch Ball	B-4
63864	Class V Trailer Hitch Ball	B-4
63880	Class I Trailer Hitch Ball	B-3
63881†	Class I Trailer Hitch Ball	B-25

PART NO.	DESCRIPTION	PAGE NUMBER
63882	Class I Trailer Hitch Ball	B-3
63884	Class I Trailer Hitch Ball	B-3
63885†	Class I Trailer Hitch Ball	B-25
63887	Class II Trailer Hitch Ball	B-4
63888†	Class II Trailer Hitch Ball	B-25
63889	Class II Trailer Hitch Ball	B-4
63896	Class V Trailer Hitch Ball	B-4
63897†	Class V Trailer Hitch Ball	B-25
63899	Class IV Trailer Hitch Ball	B-4
63907†	Class IV Trailer Hitch Ball	B-25
63908	Class IV Trailer Hitch Ball	B-4
63909	Class IV Trailer Hitch Ball	B-4
63910†	Class IV Trailer Hitch Ball	B-25
63911	Weight Distributing Shank	E-7, B-13, B-14, B-17
63912	Class II Trailer Hitch Ball	B-5
63971	Weight Distributing Shank	E-7
64 0801	Replacement Part - Coupler Repair Kit	K-12
6425	Gooseneck Trailer Hitch Template	G-7
6495	Winch Mounting Plate	A-10, L-12
6502	Cargo Carrier - Trailer Hitch Mount	I-6
65509†	Weight Distributing Kit - Round Bar	E-14
6562	Trailer Wire Emulator	C-33
6565	Current Monitor	C-33
6580†	Trailer Hitch Adjustable Ball Mount	B-27
66 0801	Replacement Part - Coupler Repair Kit	K-8
66006	Weight Distributing Kit - Trunnion Bar	E-6
66009	Replacement Part - WD	E-11
66010	Replacement Part - WD	E-11
66014	Replacement Part - WD	E-10, E-11
66020	Weight Distributing Kit - Trunnion Bar	E-6
66021	Weight Distributing Kit - Trunnion Bar	E-6
66022	Weight Distributing Kit - Trunnion Bar	E-6
6604	Trailer Brake Grease Seal	N-8
6605	Trailer Brake Grease Seal	N-8
66072	Weight Distributing Kit & Sway Control	E-5
66073	Weight Distributing Kit & Sway Control	E-5
66074	Weight Distributing Kit & Sway Control	E-5
66075	Weight Distributing Kit & Sway Control	E-5
66082	Weight Distributing Kit & Sway Control	E-5, 0-2
66083	Weight Distributing Kit & Sway Control	E-5
66084	Weight Distributing Kit & Sway Control	E-5
66086†	Weight Distributing Kit & Sway Control	E-14
66087†	Weight Distributing Kit & Sway Control	E-14
66088†	Weight Distributing Kit & Sway Control	E-14
66130	Weight Distributing Kit & Sway Control	E-5
66131	Weight Distributing Kit - Trunnion Bar	E-6
6637	Replacement Part - WD	E-8
66540	Weight Distributing Kit - Trunnion Bar	E-6, E-6
66541	Weight Distributing Kit - Trunnion Bar	E-6
66542	Weight Distributing Kit - Trunnion Bar	E-6, 0-2
66557	Weight Distributing Kit - Light Weight	E-4
66558	Weight Distributing Kit - Light Weight	E-4
66559	Weight Distributing Kit & Sway Control	E-4
66560	Weight Distributing Kit & Sway Control	E-4
66561	Weight Distributing Kit & Sway Control	E-4
6658	Trailer Brake Grease Seal	N-8
67 0801	Trailer Coupler Repair Kit	K-8
6715	Trailer Hitch Spare Tire Carrier	A-10
67509†	Weight Distributing Kit - Round Bar	E-14, 0-2
6758	Trailer Hitch Work Step	A-10
6771	Trailer Hitch Skid Shield	A-10
6810	Drill Bit	A-9
6811	Drill Bit	A-9
6811S00	Replacement Part	J-10
68220	Fifth Wheel Coupler	H-2
690020	Ratchet Jack	J-26
690071	Ratchet Jack	J-26
6927	Trailer Brake Control Mounting Kit	D-7
7000	Battery Switch	C-31
7000100	Trailer Accessories	N-12, N-16

PART NO.	DESCRIPTION	PAGE NUMBER
7000-S	Battery Switch	C-31
7001	Battery Switch	C-31
7001-S	Battery Switch	C-31
7005300	Trailer Coupler Lock	B-23
7006100	Trailer Hitch and Coupler Lock	B-23
7010	Trailer Hitch Tube Cover	B-24
7010A	Circuit Breaker	C-32
7010A-S	Circuit Breaker	C-32
7011800300	Trailer Jack Male Mount	J-14, J-31
7011A	Circuit Breaker	C-32
7011A-S	Circuit Breaker	C-32
7012A	Circuit Breaker	C-32
7012A-S	Circuit Breaker	C-32
7013A	Circuit Breaker	C-32
7013A-S	Circuit Breaker	C-32
701466	Sidewind Crank Assembly	J-20, J-34
702275	5-Flat Connector Harness - Trailer End	C-15
7022A	Circuit Breaker	C-32
7022A-S	Circuit Breaker	C-32
702305	5-Flat Connector Harness - Vehicle End	C-15
702405	5-Flat Connector Harness - Trailer End	C-15
7033400	Farm Multi-Jack	J-26
70-38-010	Round Reflectors w/ Adhesive Mounting	M-43
70-38-020	Round Reflectors w/ Adhesive Mounting	M-43
7048400	Farm Multi-Jack Foot Plate	J-26
7050	Trailer Hitch Tube Cover	B-24
70-55-010	Round Reflectors w/ Adhesive Mounting	M-43
70-55-020	Round Reflectors w/ Adhesive Mounting	M-43
7060900	Farm Multi-Jack	J-26
7061520	Farm Multi-Jack Handle Holder	J-26
7064120	Farm Multi-Jack Repair Kit	J-26
7064200	UTV Multi-Jack	J-26
70-68-010	Round Reflectors w/ Center Mounting Hole	M-43
70-68-020	Round Reflectors w/ Center Mounting Hole	M-43
707103	4-Flat Connector Harness - Trailer End	C-12
707104	4-Flat Connector Harness - Trailer End	C-12
707105	5-Flat Connector Harness - Trailer End	C-15
70-71-170	Round Reflectors w/ Center Mounting Hole	M-43
70-71-175	Round Reflectors w/ Center Mounting Hole	M-43
70-71-180	Rectangular Reflectors	M-42
70-71-181	Rectangular Reflectors	M-42
7071300	Sport Utility Jack	J-26
70-72-020	Conspicuity Reflectors	M-43
70-72-030	Conspicuity Reflectors	M-43
707250	Trailer Connector Adapter - 7 to 5-Flat	C-26
707254	4-Flat Connector Harness - Loop	C-12
707255	5-Flat Connector Harness - Loop	C-15
707261	4-Flat Connector Harness - Trailer End	C-12, M-8, M-9, M-20
707270	4-Flat Connector Harness - Trailer End	C-12
707272	4-Flat Connector Harness - Vehicle End	C-12
707273	5-Flat Connector Harness - Vehicle End	C-15
707275	4-Flat Connector Harness - Vehicle End	C-12, M-8, M-9, M-18, M-20, M-23
707281	Trailer Connector Adapter - 6 to 4-Flat	C-26
707282	Trailer Connector Adapter - 7 to 4-Flat	C-26
707283	5-Flat Connector Harness - Trailer End	C-15
707285	4-Flat Connector Harness - Trailer End	C-12
707286	4-Flat Connector Harness - Trailer End	C-12
70-78-010	Oblong Reflectors	M-42
70-78-020	Oblong Reflectors	M-42
70-78-050	Oblong Reflectors	M-42
70-78-060	Oblong Reflectors	M-42
7086500	Farm Multi-Jack	J-26
7088900	Farm Multi-Jack	J-26
71-78-010	Oblong Reflectors	M-42
71-78-020	Oblong Reflectors	M-42
719063	Replacement Part	M-8, M-9, M-10, M-11, M-19, M-21, M-24, M-37
7200†	Dielectric Grease	C-34

PRODUCT INDEX

PART NO.	DESCRIPTION	PAGE NUMBER
7200Pt	Dielectric Grease	C-34
72783	Trailer Coupler Lock	B-23
73864	Tail Light Kit	M-18
7390	Trailer Hitch Adjustable Ball Mount	B-14
74099t	Trailer Hitch Tube Cover	B-29
74184	Pre-wired Adapter	C-23
74342	Trailer Hitch Ball Wrench	A-10, B-24
74-38-010	Round Reflectors w/ Adhesive Mounting	M-43
74-38-020	Round Reflectors w/ Adhesive Mounting	M-43
74527DT	Arched Loading Ramp	I-14
74547t	Trailer Hitch Tube Cover	B-29
74-55-010	Round Reflectors w/ Adhesive Mounting	M-43
74-55-020	Round Reflectors w/ Adhesive Mounting	M-43
74607	Trailer Connector Adapter - 7 to 4-Flat	C-26
74633	4-Way Circuit Tester	C-33
74641	Storage Box	C-30
74645	Plug to Plug Adapter	C-26
74-68-010	Round Reflectors w/ Center Mounting Hole	M-43
74-68-020	Round Reflectors w/ Center Mounting Hole	M-43
74682	Tow Harness Wiring Package	C-5
74700	Trailer Hitch Safety Chain Link	N-14
74-71-170	Round Reflectors w/ Center Mounting Hole	M-43
74-71-175	Round Reflectors w/ Center Mounting Hole	M-43
74-71-180	Rectangular Reflectors	M-42
74-71-181	Rectangular Reflectors	M-42
74-72-040	Conspicuity Reflectors	M-43
74-78-010	Oblong Reflectors	M-42
74-78-020	Oblong Reflectors	M-42
75193	Class III Trailer Hitch	O-2
7585	Bench Tester	C-33
767940	Trailer Connector Adapter - 7 to 5-Flat	C-26
767943t	Trailer Wire Plug Tester	C-34
7685	Trailer Brake Control Mounting Kit	D-7
7686	Replacement Part - Brake Control Bracket	D-7
76902	Euro Trailer Hitch	A-2
76903	Euro Trailer Hitch	A-2
76904	Euro Trailer Hitch	A-2
76905	Euro Trailer Hitch	A-2
76906	Euro Trailer Hitch	A-2
76907	Euro Trailer Hitch	A-2
76908	Euro Trailer Hitch	A-2
76910	Euro Trailer Hitch	A-2
76911	Euro Trailer Hitch	A-2
76912	Euro Trailer Hitch	A-2
78007	Trailer Connector Adapter - 7 to 4-Flat	C-27
78117	Trailer Connector Adapter - 7 to 4-Flat	C-27
78118	Trailer Connector Adapter - 7 to 5-Flat	C-27
7865	Trailer Brake Control Harness	D-7
787159	4-Flat Connector Harness - Loop	C-14
787206	Trailer Connector Adapter - 5 to 5-Flat	C-27
787207	Trailer Connector Adapter - 7 to 5-Flat	C-27
787208	Trailer Connector Adapter - 7 to 5-Flat	C-27
787264	4-Flat Connector Harness - Trailer End	C-14
787268	4-Flat Connector Harness - Trailer End	C-14
787270	4-Flat Connector Harness - Trailer End	C-14
787274	4-Flat Connector Harness - Trailer End	C-14
787302	7-Way Ag Connector - Trailer End	C-24
787303	7-Way Ag Connector - Vehicle End	C-24
787304	7-Way Ag Connector - Trailer End	C-24
787305	7-Way Ag Connector - Vehicle End	C-24
787535	7-Way Junction Box	C-30
7894	Replacement Part - Brake Control Wiring	D-7
800075	Topwind Crank Assembly	J-20, J-34
800090	Sidewind Crank Assembly	J-20, J-34
800102	Sidewind Crank Assembly	J-20, J-34
8001090283	Tandem Trailer Jack Handle	J-25, J-34
800144	Sidewind Crank Assembly	J-33
800148	Sidewind Crank Assembly	J-34
80037t	Trailer Hitch Tube Cover	B-29
80037-012t	Trailer Hitch Tube Cover	B-29
80058-002t	Trailer Hitch Starter Ball Mount Kit	B-26

PART NO.	DESCRIPTION	PAGE NUMBER
8010	Trailer Tester	C-33
80100t	Trailer Tester	B-29
80106t	Trailer Tester	B-29
802650	Replacement Part	M-48
802651	Replacement Part	M-48
802652	Replacement Part	M-48
80300	Trailer Hitch Adapter	B-15
80301	Trailer Hitch Adapter	B-15
80303	Trailer Hitch Adapter	B-15
80304	Trailer Hitch Adapter	B-15
80305	Trailer Hitch Extension	B-16
80306	Trailer Hitch Extension	B-16
80307	Trailer Hitch Extension	B-16
80404t	Dual-Ball Trailer Hitch Ball Mount	B-27
80406	Dual-Ball Trailer Hitch Ball Mount	B-12
80410t	Clevis Trailer Hitch Ball Mount	B-27
80425	Tri-Ball Trailer Hitch Ball Mount	B-12
80426	Tri-Ball Trailer Hitch Ball Mount	B-12
80472-002t	Trailer Hitch Starter Ball Mount Kit	B-26
80500	Trailer Brake Control - Timed	D-6
80550	Trailer Brake Control - Timed	D-6
80583-002t	Trailer Hitch Starter Ball Mount Kit	B-26
80644-002t	Trailer Hitch Starter Ball Mount Kit	B-26
80791	Tri-Ball Trailer Hitch Ball Mount	B-12
80795t	Dual-Ball Trailer Hitch Ball Mount	B-27
80796	Dual-Ball Trailer Hitch Ball Mount	B-12
80797t	Dual-Ball Trailer Hitch Ball Mount	B-27
80798	Dual-Ball Trailer Hitch Ball Mount	B-12
80799	Tri-Ball Trailer Hitch Ball Mount	B-12
80806	Trailer Hitch Receiver Tube	A-9
80812	Trailer Hitch Receiver Tube	A-9
80818t	Trailer Hitch Receiver Tube	A-143
80953t	Trailer Hitch Tube Cover	B-29
80980t	Trailer Hitch Tube Cover	B-29
81378	Class II Step Bumper Trailer Hitch	A-8
82201	Motorhome Hitch	A-8
8260001	Heavy-Duty Ag Lights	M-48
8260101	Heavy-Duty Ag Lights	M-48
8260501	Heavy-Duty Ag Lights	M-48
8260502	Heavy-Duty Ag Lights	M-48
8260601	Heavy-Duty Ag Lights	M-48
8260602	Heavy-Duty Ag Lights	M-48
8261001	Heavy-Duty Ag Lights	M-48
8261002	Heavy-Duty Ag Lights	M-48
8261501	Heavy-Duty Ag Lights	M-48, M-49
8261601	Heavy-Duty Ag Lights	M-48, M-49
8261605	Heavy-Duty Ag Lights	M-48
83001	Fifth Wheel Trailer Hitch Lube Plate	F-8
83002	Fifth Wheel Trailer Hitch Lube Plate	F-8
83003	Fifth Wheel Trailer Hitch Lube Plate	F-8
83004	Fifth Wheel Trailer Hitch Lube Plate	F-8
83058-002t	Trailer Hitch Starter Ball Mount Kit	B-26
83238-002t	Trailer Hitch Starter Ball Mount Kit	B-26
8339	Gooseneck Trailer Hitch Head	G-6
83407-002	Trailer Hitch Starter Ball Mount Kit	B-9
83501	Trailer Brake Control - Timed	D-5
83504	Trailer Brake Control - Timed	D-5
83583-002t	Trailer Hitch Starter Ball Mount Kit	B-26
83637t	Class I Trailer Hitch Drawbar Kit	B-25
83644-002t	Trailer Hitch Starter Ball Mount Kit	B-26
83660	Sway Control - Friction	E-7, O-2
85208	2-Flat Connector Harness	C-14
85216	Plug to Plug Adapter	C-26
85218	4-Flat Cover	C-14
85219	7-Way Connector - Car End	C-6
85343	Trailer Connector Adapter - 7 to 4-Flat	C-26
8549100	7-Way Connector Harness - Trailer End	C-19
8551511	7-Way Connector - Vehicle End	C-6
85-767010	Accessory Item	M-10
86005t	Fifth Wheel Coupler Rebuild Kit	H-7
86007	Goose Box™ Air System Service Kit	G-2

PART NO.	DESCRIPTION	PAGE NUMBER
90-03-327	Replacement Part	M-35
90-03-328	Replacement Part	M-23, M-35
90-03-336	Replacement Part	M-20
90160	Trailer Brake Control - Proportional	D-3
90195	Trailer Brake Control - Proportional	D-3
902501	Trailer Brake Control - Proportional	D-2
90253	Trailer Brake Control - Proportional	D-2
9030	Trailer Brake Control - Proportional	D-4
90885	Trailer Brake Control - Proportional	D-3
94241DT	Bungee Cargo Net	I-12
9424200	Bungee Cargo Net	I-12
94247DT	Cambuckle Tie Down Strap	I-11
94252DT	Ratchet Tie Down Strap	I-11
94255DT	Ratchet Tie Down Strap	I-11, I-12
94260DT	Ratchet Tie Down Strap	I-11
94262DT	Ratchet Tie Down Strap	I-11
94263DT	Tow Strap with Hooks	I-14
94264DT	Tow Strap with Loops	I-14
94273DT	Ratchet Tie Down Strap	I-11, I-12
94316	Fifth Wheel Coupler Rebuild Kit	H-5
9460	Gooseneck Trailer Hitch Head	G-5
9464	Gooseneck Trailer Hitch Head	G-5
9465	Gooseneck Trailer Hitch Head	G-5
9466	Gooseneck Trailer Hitch	G-5
9467	Gooseneck Trailer Hitch	G-5
9468	Gooseneck Trailer Hitch Head	G-5
94716	Gooseneck RV Coupler	G-2, H-3
94720	Gooseneck RV Coupler	G-2, H-3
9480	Gooseneck Fifth Wheel Trailer Hitch	F-5, G-4
94815DT	Ratchet Tie Down Strap	I-11
94816DT	Cambuckle Tie Down Strap	I-11
94824DT	Ratchet Tie Down Strap	I-12
94828DT	Ratchet Tie Down Strap	I-11
94853DT	Ratchet Tie Down Strap	I-11
95108DT	Ratchet Tie Down Strap	I-11
95111DT	Ratchet Tie Down Strap	I-11
95118DT	Ratchet Tie Down Strap	I-12
95120DT	Ratchet Tie Down Strap	I-12
95142DT	Ratchet Tie Down Strap	I-11
95150DT	Arched Loading Ramp	I-14
95151DT	Straight Loading Ramp	I-14
95167DT	Tree Saver Strap	I-14
95235DT	Tie Down Anchor	I-14
95236DT	Tie Down Anchor	I-14
95451DT	Tow Strap	I-14
95463DT	Ratchet Tie Down Strap	I-11
95466DT	Ratchet Tie Down Strap	I-12
95473DT†	Ratchet Tie Down Strap	I-17
A2003C0317	Adjustable Channel Mount Trailer Coupler	K-8
A2005C0317	Adjustable Channel Mount Trailer Coupler	K-8
A200C 0317	Adjustable Channel Mount Trailer Coupler	K-8
A200S 0303	Adjustable Channel Mount Trailer Coupler	K-12
A2563C0317	Adjustable Channel Mount Trailer Coupler	K-8
A2565C0317	Adjustable Channel Mount Trailer Coupler	K-8
A256C 0317	Adjustable Channel Mount Trailer Coupler	K-8
A256S 0303	Adjustable Channel Mount Trailer Coupler	K-12
AC300 0300	Adjustable Coupler Channel	K-7, K-12
AC500 0300	Adjustable Coupler Channel	K-7, K-12
BB19800112	Wheel Bearing Protector Cover	N-10
BGR20 0101	Boat Roller Guides	N-12
BP198S0304	Wheel Bearing Protector Cover	N-10
BP244S0304	Wheel Bearing Protector Cover	N-10
BP244S0604	Wheel Bearing Protector Cover	N-10
BPC1980604	Wheel Bearing Protector Cover	N-10
CA5550301	Caster Adapter Plates	J-32
CE555 0101	Poly Wheels	J-14, J-31
CH 0701	Trailer Coupler Handle	K-12
CHA0010140	Trailer Hitch Safety Chain	N-13
CHA0010340	Trailer Hitch Safety Chain	N-13
CHA0020324	Trailer Hitch Safety Chain	N-13
CHA0030140	Trailer Hitch Safety Chain	N-13

PART NO.	DESCRIPTION	PAGE NUMBER
CHA0040324	Trailer Hitch Safety Chain	N-13
CHA0050324	Trailer Hitch Safety Chain	N-13
CHA0060324	Trailer Hitch Safety Chain	N-13
CHA0070324	Trailer Hitch Safety Chain	N-13
CLK15 0100	Cable Lock	B-23
CR8008	Bunk Carpeting	N-12
CR8012	Bunk Carpeting	N-12
CS730300	HD 2-Speed Tandem Landing Gear	J-20, J-25
DF35000324	Drop Legs	J-30
E333050303	A-Frame Trailer Coupler	K-12
E338050303	A-Frame Trailer Coupler	K-12
E438050303	A-Frame Trailer Coupler	K-12
E443050303	A-Frame Trailer Coupler	K-12
EA20000103	A-Frame Trailer Jack - 2,000 lbs	J-27, O-4
EA20000303	A-Frame Trailer Jack - 2,000 lbs	J-27
EA20000340	A-Frame Trailer Jack - 2,000 lbs	J-27, O-4
EJ10000101	Pro Series™ Bolt-On Jack	J-9
ETC 0101	Spare Tire Carrier	N-15
ETCHL 0700	Spare Tire Carrier	N-15
ETCLB 0700	Spare Tire Carrier	N-15
ETCSTL0701	Spare Tire Carrier	N-15
F2000 0301	Foot Plates	J-31
F3500 0324	Foot Plates	J-31
FP20000201	Removable Disc Feet	J-31
FW16000101	Trailer Winch	L-4
FW20000101	Trailer Winch	L-4
FW32000101	Two Speed Trailer Winch	L-4
FW3200S01	Replacement Part - Trailer Winch	L-4
GB150 0100	Boat Trailer Visual Guide Post	N-12
GB44 0101	Boat Trailer Visual Guide Post	N-12
GN24 0200	Gooseneck Trailer Coupler	K-5
HD25000101	Marine and Recreational Trailer Jack	J-9
HD50000101	Marine and Recreational Trailer Jack	J-9
HDDS 0201	Trailer Jack Handle	J-34
HDPB230101	Trailer Tongue Bolt-On Hinge Kit	K-11
HDPB330101	Trailer Tongue Bolt-On Hinge Kit	K-11
HDPB340101	Trailer Tongue Bolt-On Hinge Kit	K-11
HDPB350101	Trailer Tongue Bolt-On Hinge Kit	K-11
HDSTC 0101	Spare Tire Carrier	N-15
JC1000300	Trailer Hitch Safety Chain Clip	N-14
KR10000301	Brake Winch	L-8
KR15000301	Brake Winch	L-8
LP516 0201	Replacement Part	J-30
MKG0182	REESE Header Card	O-6
MKG0188	Tekonsha Header Card	O-6
MKG0196	Draw-Tite Banner	O-7
MKG0198	REESE Hours of Operation Sign	O-7
MKG0202	REESE Banner	O-7
MKG0205	REESE Header Card	O-6
MKG0209	BULLDOG Header Card	O-6
MKG0216	Draw-Tite Hours of Operation Sign	O-7
MKG0218	Draw-Tite Hitch Header Card	O-2, O-6
MKG0219	Draw-Tite Header Card	O-6
MKG0255	REESE Fifth Wheel Sign	O-3, O-6
MKG0346	REESE Fifth Wheel Sign	O-3, O-6
MKG0358	Tekonsha ZCI Display	O-4
MKG0466	REESE Fifth Wheel Header Card	O-6
MKG1276	BULLDOG Banner	O-7
MKG1281	REESE Weight Distribution Sign	O-2
MKG1929	Draw-Tite Gooseneck Window Cling	O-7
MKG2090	REESE Banner	O-7
MKG2097	BULLDOG Jack Sign	O-5
MKG2136	Tekonsha ZCI Brochure	O-4
MKG2806	REESE Hours of Operation Sign, French	O-7
MKG3253	Fulton Header Card	O-6
OML 0127	Outboard Motor Lock	N-12
P20520-00	Retaining Ring Mounting Brackets	J-31
P9012-00	Trailer Jack Mounting Bracket	J-12
P9222-00	Retaining Ring Mounting Brackets	J-14, J-31
PD110101	POD Hazard	N-16
PD110200	POD Hazard	N-16

PRODUCT INDEX

PART NO.	DESCRIPTION	PAGE NUMBER
PD110700	Roadside Warning Lights	N-16
PL4 0201	Coupler Pin/Lanyard	K-8
PQM19-00	Trailer Jack Mount Bracket	J-14, J-31
R4000-1†	Vehicle Roof Rack	I-17
R7001†	Vehicle Roof Rack - Fit Kit Direct Mount	I-17
R7002†	Vehicle Roof Rack - Fit Kit Direct Mount	I-17
R7003†	Vehicle Roof Rack - Track Mount Adapter	I-17
R7010†	Vehicle Roof Rack - Fit Kit Direct Mount	I-17
R7011†	Vehicle Roof Rack - Fit Kit Direct Mount	I-17
R7012†	Vehicle Roof Rack - Fit Kit Direct Mount	I-17
RBU43	Vehicle Roof Rack	I-3
RBU47	Vehicle Roof Rack	I-3
RBU53	Vehicle Roof Rack	I-3
RBU60	Vehicle Roof Rack	I-3
RE43†	Vehicle Roof Rack	I-17
RE47†	Vehicle Roof Rack	I-17
RE53†	Vehicle Roof Rack	I-17
RE60†	Vehicle Roof Rack	I-17
RV20000103	A-Frame Trailer Jack - 2,000 lbs	J-27, O-4
RV20000303	A-Frame Trailer Jack - 2,000 lbs	J-27
SJ1 0300	Trailer Stabilizer	J-30
SJ2 0324	Trailer Stabilizer	J-30
SJ3 0300	Trailer Stabilizer	J-30
SJ4 0324	Trailer Stabilizer	J-30
SJ5 0324	Trailer Stabilizer	J-30
SJL8 0300	Trailer Stabilizer	J-30
SJW 0324†	Trailer Stabilizer	J-36
SPAQ500300†	Trailer Jack A-Plate	J-37
SPB50 0300	Trailer Jack Bottom Support Plates	J-32

PART NO.	DESCRIPTION	PAGE NUMBER
SPBQ500300†	Trailer Jack A-Plate	J-37
ST400	Fifth Wheel Turret	H-5
ST400-5AS16K	Fifth Wheel Coupler	H-5
ST400-SW16K†	Fifth Wheel Coupler	H-7
ST400-SW19K†	Fifth Wheel Coupler	H-7
STC1000101	Spare Tire Carrier	N-15
STC1000301	Spare Tire Carrier	N-15
STL 0603	Spare Tire Lock	N-15
SW16K†	Fifth Wheel Coupler	H-7
SW19K†	Fifth Wheel Coupler	H-7
SWW-01	Fifth Wheel Wedge Kit	H-6
SWW-03	Fifth Wheel Wedge Kit	H-6
SWW-04	Fifth Wheel Wedge Kit	H-6
SWW-05	Fifth Wheel Wedge Kit	H-6
SWW-06	Fifth Wheel Wedge Kit	H-6
SWW-07	Fifth Wheel Wedge Kit	H-6
SWW-08	Fifth Wheel Wedge Kit	H-6
SWW-09	Fifth Wheel Wedge Kit	H-6
TJ12000101	Swivel Trailer Jack - 1,200 lbs	J-9
WB100 0700	Trailer Wheel Bearing Protector	N-9
WB106 0700	Trailer Wheel Bearing Protector	N-9
WB138T0700	Trailer Wheel Bearing Protector	N-9
WC325 0100	Trailer Winch Cable	L-6, L-7, L-8
WC750 0100	Trailer Winch Cable	L-6, L-7, L-8
WS20HD0600	Trailer Winch Strap	L-5, L-6
XP10 0101	Marine and Recreational Trailer Jack	J-9
XP15 0101	Marine and Recreational Trailer Jack	J-9
XP15L 0101	Marine and Recreational Trailer Jack	J-9
XPD15L0101	Marine and Recreational Trailer Jack	J-9