



TSP[®]

TOP STREET PERFORMANCE

2021 PRODUCT CATALOG

ABOUT THE COMPANY



Top Street Performance is a privately-owned company based in Southern California. We offer a wide range of products for both classic and modern American muscle. We are constantly striving to expand our catalog, improve our products and services, and be the first call you make when you're looking for parts for your hot rod or muscle car.

Throughout our history in the automotive aftermarket industry, we've cultivated excellent relationships with a growing number of premium manufacturers. This allows us to provide high-quality parts at bargain pricing – all guaranteed by our one-year warranty. Our products range from dress-up components such as valve covers and oil pans, to electrical and ignition parts such as high-torque starters and high-performance electronic distributors.

If you're looking for a part or two for your resto-mod or performance upgrade, or if you're a shop or wholesale distributor looking to add TSP's high-quality performance parts to your product line, we've got you covered. Customer service is at the center of everything we do at Top Street Performance, and our friendly and knowledgeable staff is ready to assist you with anything you may need.

Top Street Performance is a proud member of the Specialty Equipment Market Association (SEMA).

Top Street Performance: Quality. Performance. Period.®



 **WARNING:** Cancer and Reproductive Harm

LS PRODUCTS	3	DRESS UP	107
Velocity® by TSP Induction Kits	3-4	LS Valve Covers	107-108
Velocity® by TSP Products	5-8	Chevy Valve Covers	108-109
LS Products	9-16	Ford Valve Covers	110
Wiring Harnesses & Adapters	17	Ford FE Valve Covers	111
LS Coil Bracket Kits	19-20	Mopar Valve Covers	111
LS Relocation Brackets	21-22	Finned Fabricated Valve Covers	112
LS Serpentine Front Drive System	23-24	Valve Cover Gaskets	113-114
FORD COYOTE 5.0L	25	Push-in Breathers	115
Ford Coyote 5.0L	25-26	Clamp-on Breathers	115-116
FRONT DRIVE SYSTEM	27	Oil Plugs & Cap	116
SBC & BBC Front Drive System	29-31	Air Cleaner Kits	116
SBC & BBC Front Drive System with Gilmer Pulley Kit	31-32	Oil Pans	117-119
IGNITION	33	Oil Pan Pick-ups	119-120
Pro Series Pro Billet Distributors	33-35	Oil Pan Gaskets	120
Power Pack Ignition Kit	36	Transmission Oil Pans & Gaskets	120-121
Pro Series Ready to Run Distributors	37-41	Mirrors, Window & Door Handles	121-122
Pro Series Ready to Run Kit	42	Polished Aluminum Knobs	122
HEI Distributors	43-46	Gas & Brake Pedals	122-123
Pro Billet Distributors	47-48	FUEL DELIVERY	125
Ready to Run Distributors	49-50	Electric Fuel Pump & Filter Mounting Bracket Kit	125-127
EFI Distributors	51-52	Fuel Filter Regulator	128
Ignition Accessories	53-62	Electric Fuel Pumps & Regulators	129-130
TSP® Ignition Wire Sets, Spark Plug Boot Protectors	63-64	Micro Electric Fuel Pumps & Filters	130
ELECTRICAL	65	Mechanical Fuel Pumps	131-133
Alternators	65-67	Fittings, Block-Off/Mounting Plates	133
Starters	69-70	Gauges, Throttle Cable Bracket	133-134
COOLING	71	Aluminum Carb Spacers & Adapters	134
Mechanical Water Pumps	71-73	Phenolic Carb Spacer	134-135
Electric Water Pumps	74	Throttle, Kick-Down & Choke Cables	135
Water Necks	75	Fuel Lines & Fuel Logs	135-136
A/C Compressors	76	Phenolic Manifold Heat Spacers & Gaskets	136
Overflow Tanks	77	STEERING	137
Universal Transmission Oil Coolers	78	Power Steering Pumps	137-138
Aluminum Fan Shroud Kits	79-80	Power Steering Pump Accessories	138
Aluminum Fan Shrouds	81	CYLINDER HEADS	139
Radiators	82	Cylinder Heads	139-140
Radiator Cap, Radiator Hose Kit, Heater Hose Kit, Flap	82	HOT ROD	141
Electric Cooling Fans, Fan Accessories	83-86	'32 Ford Rear-End Kits & Grill Shells	141
BRACKET & PULLEYS	87	Chevy & Ford Column Shift Linkage	142
Bracket Kits	87-89	Electric Vacuum Pump	142
Gilmer Style Pulley Kits	90-92	BLACK SERIES	143
Pulleys	93-96	Black Series	143-150
INTAKE MANIFOLDS	97	INSTRUCTIONS & DIAGRAMS	151
Intake Manifolds	97-99	Distributors Installation	153-154
FENDER COVER	100	Distributor Cap Dimensions	154
HARMONIC BALANCERS	101	Fan Dimensions	155-156
Harmonic Balancers	101-102	Alternator Installation & Dimensions	157-160
ROCKER ARMS	103	Starter Dimensions	161
Rocker Arms	103-105	A/C Compressor Dimensions	162
		Velocity® by TSP LS Intake Manifold	163-164
		Velocity® by TSP Ford Coyote 5.0L Intake Manifold	164
		LS Oil Pan & LS Relocation Brackets Dimension	165-166
		Valve Cover Dimensions	167



INDUCTION KIT NAME	DESCRIPTION
VL01	LS1/LS2/LS6 Low Profile Angled Velocity® Intake Manifold Kit
VL02	LS1/LS2/LS6 Low Profile Straight Velocity® Intake Manifold Kit
VL02T	LS1/LS2/LS6 High Ram Straight Velocity® Intake Manifold Kit
VL03	LS3 Low Profile Angled Velocity® Intake Manifold Kit
VL03T	LS3 High Ram Straight Velocity® Intake Manifold Kit
VL07	LS7 Low Profile Angled Velocity® Intake Manifold Kit
VL50	Ford Coyote 5.0L High Ram Angled Velocity® Intake Manifold Kit

VELOCITY[®] BY TSP

INDUCTION KITS

VELOCITY[®]



Take care of the whole top end in one shot. Combining all of TSP's high-performance Velocity[®] products, all kits include a fabricated intake manifold and billet aluminum high-pressure fuel rails. Additional options include high-flow fuel injectors and a large-bore throttle body. Kits are available in black and clear anodized.

VELOCITY[®] BY TSP

VELOCITY[®]



81001:

- Velocity[®] LS1/LS2/LS6 EFI Fabricated Intake Manifold
- 6061-T6 Aluminum
- 102mm Throttle body opening
- Velocity stacked intake runners
- Runners length are 5.0 inches long
- 3mm thick aluminum
- Compatible with Map Sensor GM 12592525
- 7 degree front angle
- Overall Height: 6.75 inches
- Finish: Black Anodized, Clear Anodized



Velocity stacks for better air flow



Compatible with Map Sensor GM 12592525

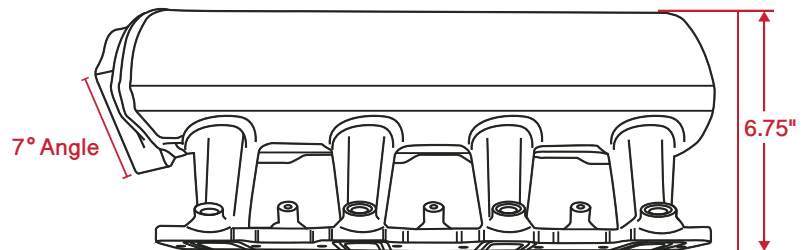



81002



81002T



81003



81003T



81007



84050



81008



81009



81010



81011



81002

Velocity® LS1/LS2/LS6, 102mm Fabricated Aluminum Intake Manifold, 0° Angle
Black, Clear Anodized

81002T (Tall Version)

Velocity® LS1/LS2/LS6, 102mm Hi-Ram Fabricated Aluminum Intake Manifold, 0° Angle
Black, Clear Anodized

81003

Velocity® LS3/L92, 102mm Fabricated Aluminum Intake Manifold
Black, Clear Anodized

81003T (Tall Version)

Velocity® LS3/L92, 102mm Hi-Ram Fabricated Aluminum Intake Manifold
Black, Clear Anodized

81007

Velocity® LS7, 102mm Fabricated Aluminum Intake Manifold
Black, Clear Anodized

84050

Velocity® 2011+ Ford Coyote 5.0L Embossed, EFI Fabricated Aluminum Intake Manifold
Black, Clear Anodized

81008

Velocity® LS1/LS2/LS6 Billet Aluminum Fuel Rail Kit
Black, Clear Anodized

81009

Velocity® LS3/L92 Billet Aluminum Fuel Rail Kit
Black, Clear Anodized

81010

Velocity® OEM Billet Aluminum Fuel Rail Kit
Black, Clear Anodized

81011

Velocity® LS7 Billet Aluminum Fuel Rail Kit
Black, Clear Anodized

84051

Velocity® Ford Coyote 5.0L Billet Aluminum Fuel Rail Kit
Black



84051



12592525

12592525

ACDelco MAP Sensors
for LS9 & LSA Applications

81012

Velocity® 102mm 4-Bolt LS CNC Machined Billet Auminum Throttle Body
Black, Natural



81012



81013



81013

Velocity® LS Throttle Cable Bracket,
Steel, 105mm
Black, Silver

81014

Velocity® 102mm Electronic CNC Machined Billet Auminum Throttle Body, 6 Pin
Black, Natural



81014



81041



81041

Velocity® 102mm Electronic CNC Machined Billet Auminum Throttle Body Housing
Black, Natural

81042

Velocity® 92mm 4-Bolt LS CNC Machined Billet Auminum Throttle Body
Black, Natural



81042



81059

81059

Velocity® LS1 Adjustable Throttle Cable

VELOCITY[®] BY TSP

FUEL INJECTORS

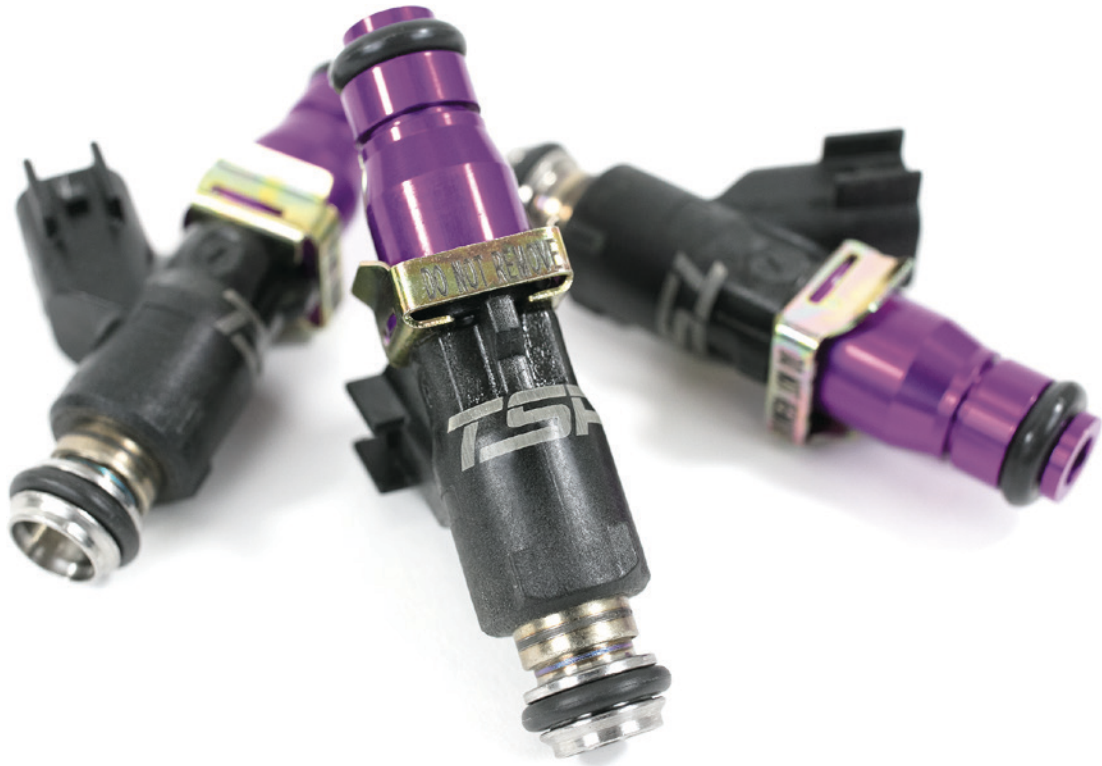

Precision. That's what matters most when it comes to fuel delivery. With TSP's high-flow Velocity[®] fuel injectors, you can expect reliable delivery of the precise amount of fuel every time. TSP Velocity[®] fuel injectors are made in the USA, assembled with top-quality parts and trusted techniques. The 81050 injector is designed to fit our LS1/LS2/LS6 and Coyote 5.0L Velocity[®] intakes and rails. The 81051 injector is designed to fit our LS3 and LS7 Velocity[®] intakes and rails.

PRODUCT NO.	DESCRIPTION	FLOW RATE
81050-36	Velocity [®] LS1/LS2/LS6/Ford Coyote 5.0L High-Flow Fuel Injector	36 lbs/hr (.380 cc/min)
81050-52	Velocity [®] LS1/LS2/LS6/Ford Coyote 5.0L High-Flow Fuel Injector	52 lbs/hr (.550 cc/min)
81050-61	Velocity [®] LS1/LS2/LS6/Ford Coyote 5.0L High-Flow Fuel Injector	61 lbs/hr (.650 cc/min)
81050-80	Velocity [®] LS1/LS2/LS6/Ford Coyote 5.0L High-Flow Fuel Injector	80 lbs/hr (.850 cc/min)

PRODUCT NO.	DESCRIPTION	FLOW RATE
81051-52	Velocity [®] LS3/LS7 High-Flow Fuel Injector	52 lbs/hr (.550 cc/min)
81051-80	Velocity [®] LS3/LS7 High-Flow Fuel Injector	80 lbs/hr (.850 cc/min)

LS PRODUCTS

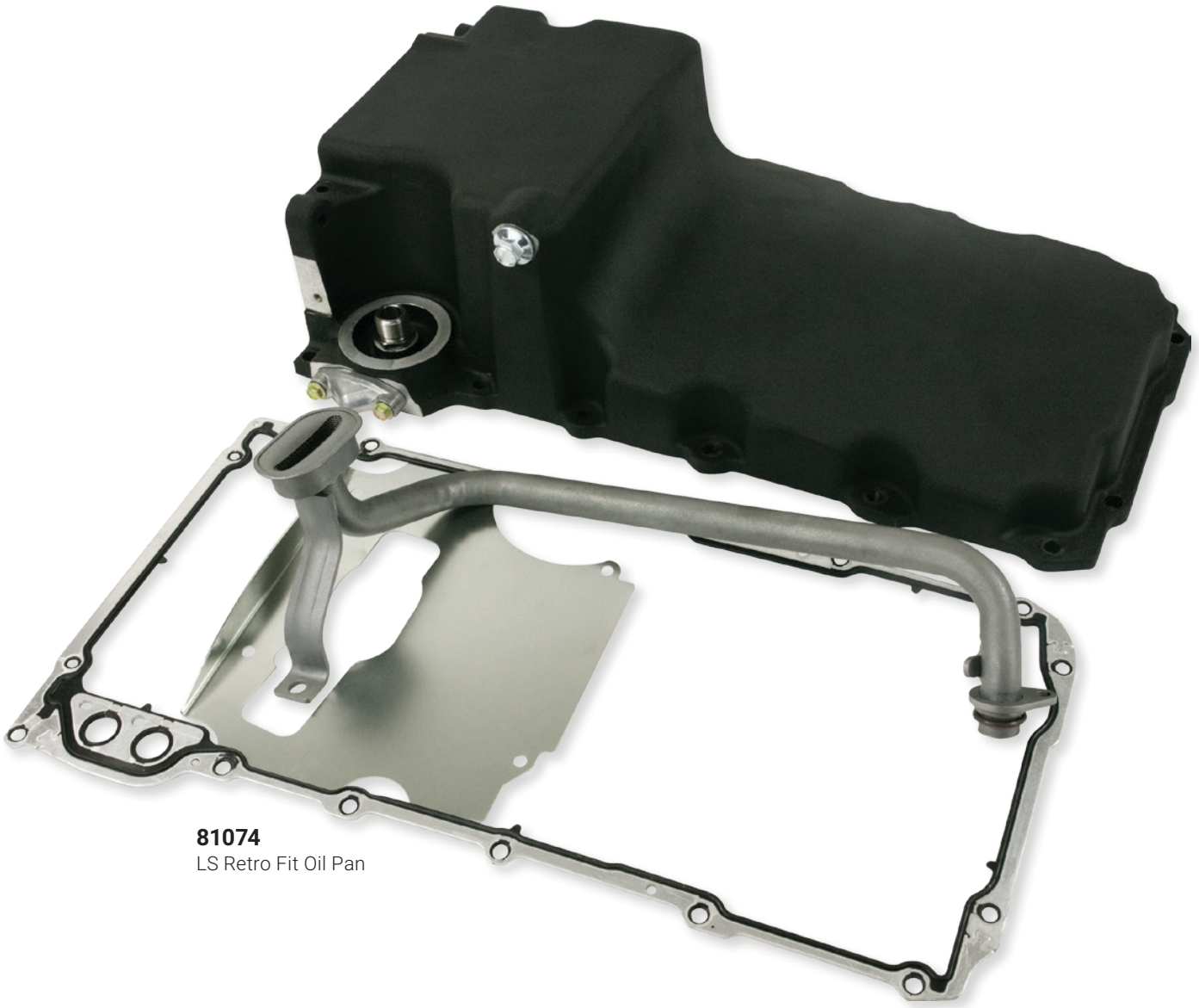

81074
LS Retro Fit Oil Pan

LS engines are among the most popular for swaps for their low expense and great power potential. Unfortunately, stock LS oil pans can't always fit where you want them to. That's where TSP's retro fit oil pan comes in. Composed of lightweight cast aluminum, it is designed to allow for increased clearance to the ground and chassis. It will fit many GM rear-wheel drive applications originally equipped with a small or big block Chevy engine and factory rear sump pan. Meticulously designed, it will mount perfectly to any wet-sump LS engine and take the stock oil filter.



81019



81070



81071



81072



81073



81075



81076



81077



81079



81006*

81019
Billet Aluminum Oil Filter Relocation Kit
Black

81070
LS Oil Pan Adapter for Oil Cooler,
-6AN ORB

81071
Oil Baffle Kit for LS Low Profile Retro Fit
Oil Pan

81072
Oil Baffle Kit for LS Retro Fit Oil Pan

81073
LS Low Profile Retro Fit Oil Pan
Black, Polished, Satin

81074
LS Retro Fit Oil Pan
Black, Polished, Satin

81075
LS Low Profile Retro Fit Oil Pan with
1/2" NPT Ports & Frame Cut Outs
Black, Polished, Satin

81076
LS Retro Fit Oil Pan, Front Sump
Black, Polished, Satin

81077
LT Retro Fit Oil Pan
Black, Polished, Satin

81079
LS Oil Dipstick and Tube
Black, Chrome

81006*
LS Oil Pan Gasket, Neoprene
- Will not fit LS7 and LS9 series engines

*OEM Replacement

81099
LS1/LS2/LS3/LS6 Engine Oil Pump
Pickup Tube Girdle



81099

81102
TSP LS SFI Certified Harmonic
Balancer Steel Damper, 360° Markings
Black



81102

81032
LS2 to LS1 Throttle Body Harness
Adapter



81032

81033
LS1 to LS3 Map Sensor Adapter



81033

81034
LS3 Map Sensor Extension Harness



81034

81043
LS1/LS6 Truss Valley Cover
Black, Chrome

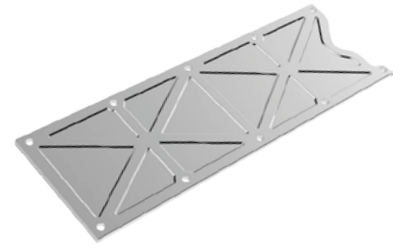

81043



81044
LS2/LS3 Truss Valley Cover
Black, Chrome



81044



81045
LS1/LS6 Finned Valley Cover
Black, Polished

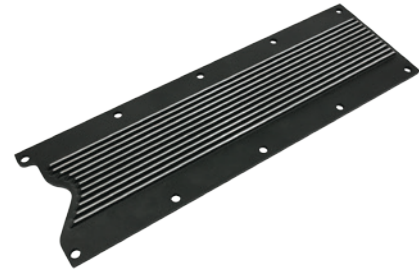

81045



81046
LS2/LS3 Finned Valley Cover
Black, Polished



81046



81047
LS1/LS6 Valley Cover Gasket



81047



81048



81054



81048
LS2/LS3 Valley Cover Gasket

81054
LS Steam Vent Kit
Black, Natural

81055
LS1/LS6 2-Piece Timing Cover with
Gasket and Seal
Black, Polished

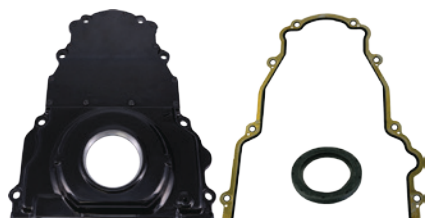

81055



81056
LS2/LS3 2-Piece Timing Cover with
CPS Provision, Harness, Gasket, and Seal
Black, Polished

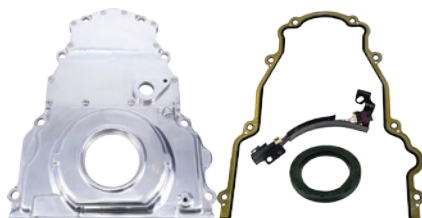

81056



81058
LS2/LS3 Camshaft Position Sensor Bracket
with Harness

12591720
ACDelco Camshaft Position Sensor



81058



12591720

81100
LS to Chevy SB Motor Mount
Adapter Plates, Brushed Billet Aluminum
Black, Natural

81101
Chevy SB/BB Polyurethane
Motor Mount, 1 unit
Red/Zinc



81100



81103
Chevy Polyurethane Transmission Mount

81104
LT to Chevy SB Motor Mount Adapter Plates
Black, Natural

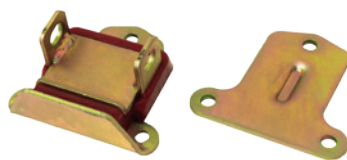

81101

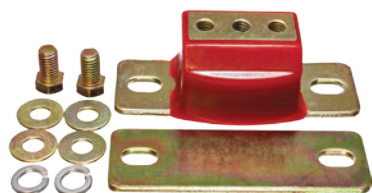

81103



81104



81150

LS to Fox Body Mustang Adapter Plates
Black, Natural



81150

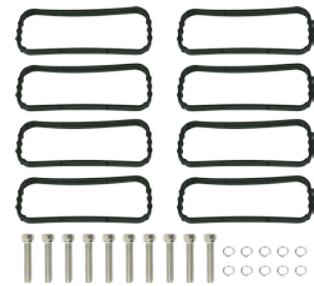

81701

81701

81001/81002 Replacement Gaskets and
Mounting Bolts

81703

81003 Replacement Gaskets and
Mounting Bolts

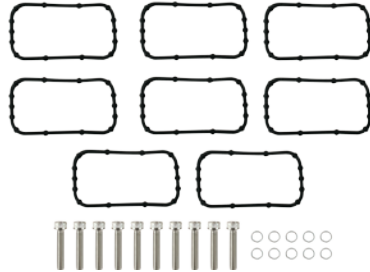

81703

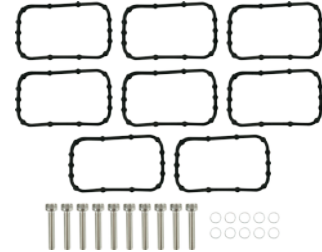

81707

81707

81007 Replacement Gaskets and
Mounting Bolts

81708

Fuel Rail Mounting Brackets for 81008

81709

Fuel Rail Mounting Brackets for 81009



81708

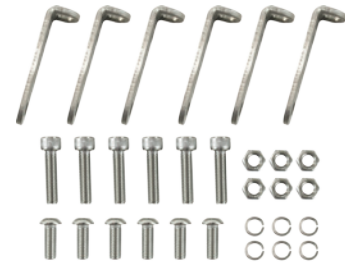

81709

81711

Fuel Rail Mounting Brackets for 81011

HC8935*

LS Truck 4.8L/5.3L/6.0L,
Aluminum Mechanical Water Pump
Fits 1999-2006, OEM Replacement
Satin

HC8937

LS 45° Aluminum Water Neck
360° Swivel
Black, Chrome

HC8937-KT

LS 45° Aluminum Water Neck
360° Swivel with 160° Thermostat
Black, Chrome

HC8938

LS Straight Aluminum Water Neck
Black, Chrome

HC8938-KT

LS Straight Aluminum Water Neck
with 160° Thermostat
Black, Chrome

*OEM Replacement

81711



HC8937-KT



HC8935*



HC8938-KT





HC8939-KT



HC8940



ES1024

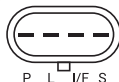

ES1025



JM7002



JM7009



JM8081-5



JM8081-6



JM8081-7



JM8082-1



HC8939

LS -12AN Fitting Water Neck and Water Pump Adapter

HC8939-KT

LS -12AN Fitting Water Neck and Water Pump Adapter with 160° Thermostat

HC8940

LS 160° Thermostat

ES1024

LS Truck AD244 Alternator, 220 AMP, Serpentine Belt, 4 Pin Connector Black, Chrome

ES1025

LS Car CS130D Alternator, 180 AMP, Serpentine Belt, 4 Pin Connector Black, Chrome

JM7002

LS 3HP High Torque Starter, Tilton Style Black, Chrome, Red

JM7009

LS 1.9HP Starter, Denso Style All Black, Black, Red

JM8081-5

LS Aluminum Fabricated Valve Cover, Center Bolt without Coil Mounts, Oil Filler Hole Black, Clear Anodized, Polished

JM8081-6

LS Aluminum Fabricated Valve Cover, Center Bolt with Coil Mounts, Oil Filler Hole Black, Clear Anodized, Polished

JM8081-7

LS Aluminum Fabricated Coil Cover, Center Bolt with Billet Oil Filler Neck, Patent # D735759 Black, Clear Anodized, Polished

JM8082-1

LS Aluminum Tall Cast Valve Cover, Center Bolt with Coil Mounts, Oil Filler Hole Black, Polished, Satin

JM8082-2

LS Aluminum Finned Cast Valve Cover and Coil Cover, Center Bolt with Coil Mounts
Black, Polished, Satin



VALVE COVER DIMENSIONS: REFER TO PAGE 167

JM8082-2



JM8082-3



GK001

LS1/LS2/LS3 Water Pump Gasket



GK002

LS1 Knock Sensor Grommet



GK003

LS1/LS2/LS3 Crank Seal

GK001



GK002

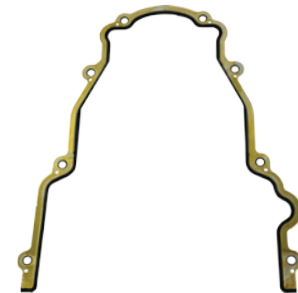

GK004

LS1/LS2/LS3 Timing Cover Gasket

GK005

LS1/LS2/LS3 Rear Cover Gasket

GK003

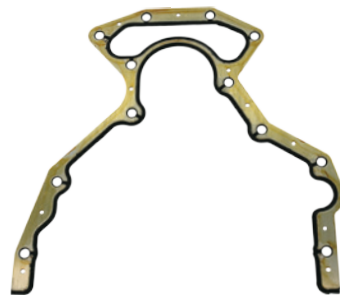

GK004



GK006

LS1/LS2/LS3 Exhaust Gasket

GK008

LS1/LS6 Head Gaskets 3.910" Bore

GK005



GK006

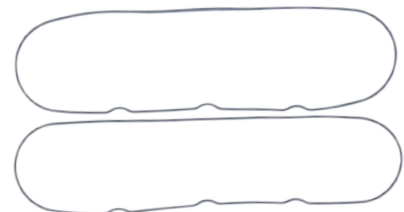

GK008

LS1/LS2/LS3 Valve Cover Gasket

GK008

GK009



GK010

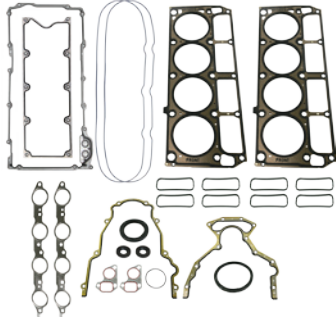

GK8101

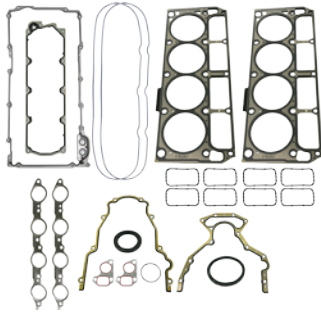

GK8103



GK012

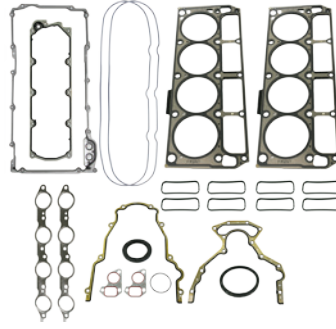

GK8102

GK010
LS1/LS2/LS3 Rear Main Seal

GK012
LS2/LS3/L92 Head Gaskets 4.080" Bore

GK8101
LS1/LS6 Engine Gasket Set

GK8102
LS2 Engine Gasket Set

GK8103
LS3/L99 Engine Gasket Set

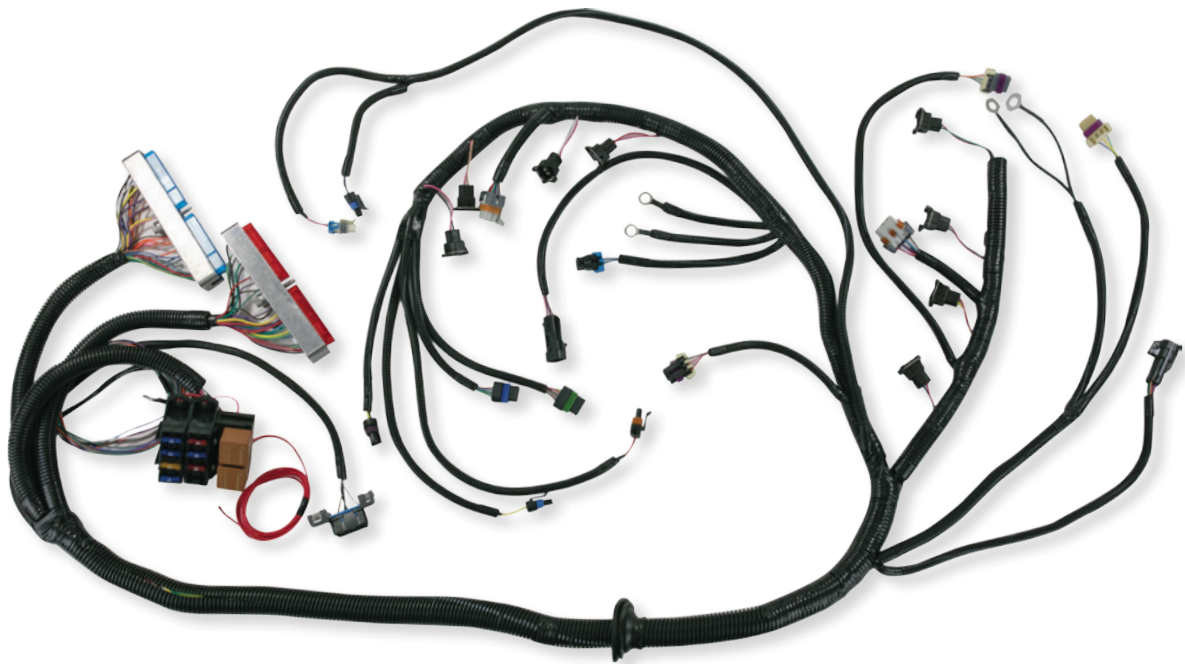

WIRING HARNESSSES & ADAPTERS

TSP's wiring harnesses and adapters are a great option when planning your LS engine swap. Available for a variety of engine and transmission combinations, they come with everything you need to hook up your powertrain. Also available is a universal body harness for your custom car project.

WIRING HARNESS

PRODUCT NO.	DESCRIPTION
WH1200	LS Truck '99-'06 with T56 Standalone Wiring Harness, DBC
WH1201	LS Truck '99-'06 with 4L60E Standalone Wiring Harness, DBC
WH1210	LS1/LS6 '97-'04 with T56 Standalone Wiring Harness, DBW
WH1211	LS1/LS6 '97-'04 with 4L60E Standalone Wiring Harness, DBW
WH1212	LS Truck '03-'07 Vortec with T56 Standalone Wiring Harness, DBW
WH1213	LS Truck '09-'14 LH6/LY5/LMG/LH8 (5.3L) with 4L60E Standalone Wiring Harness, DBW
WH1214	LS Truck '09-'14 LY6 (6.0L)/L92 (6.2L) with 4L60E Standalone Wiring Harness, DBW
WH1215	LS Truck '09-'14 LH6/LY5/LMG/LH8 (5.3L) with T56/TR6060 Standalone Wiring Harness, DBW
WH1216	LS Truck '09-'14 LY6 (6.0L)/L92 (6.2L) with T56/TR6060 Standalone Wiring Harness, DBW
WH1220	Universal 20-Circuit Wiring Harness

ADAPTER

PRODUCT NO.	DESCRIPTION
WH1100	4L60E to 4L80E Harness Adapter
81032	LS2 to LS1 Throttle Body Harness Adapter
81033	LS1 to LS3 Map Sensor Adapter
81034	LS3 Map Sensor Extension Harness
81035	EV1 to Multec Injector Adapter
81036	EV1 to EV6 Injector Adapter
81037	LS1/LS6 Ignition Coil Harness, Pair
81038	LS2/LS3/LS Truck Ignition Coil Harness, Pair
81058	LS2/LS3 Camshaft Position Sensor Bracket with Harness





LS COIL BRACKET KITS

TSP's LS ignition coil brackets are available in multiple options. If you're looking to remove the coils from atop the valve covers, the relocation brackets will do just that. They come complete with all the necessary spacers, can be mounted almost anywhere, and are designed for mounting two of the most common LS ignition coils. If you don't want to take the time to remove the coils, dress them up a bit with a pair of TSP's replacement brackets. CNC-machined from billet aluminum, they're available for multiple applications. When paired with a set of TSP coils, these brackets are guaranteed to give your LS engine a top-end facelift.



- **81015** : LS2/LS3/LS7/LS9 Car Performance Ignition Coil
- **81020** : LS Aluminum Remote Ignition Coil Mounting Bracket



- **81016** : LS2 Truck Performance Ignition Coil
- **81020** : LS Aluminum Remote Ignition Coil Mounting Bracket

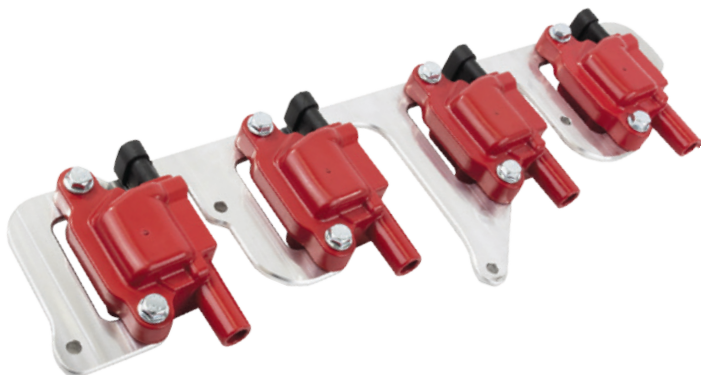

- **81015** : LS2/LS3/LS7/LS9 Car Performance Ignition Coil
- **81022** : LS Car Billet Aluminum Ignition Coil Mounting Bracket

- **81016** : LS2 Truck Performance Ignition Coil
- **81023** : LS Truck Billet Aluminum Ignition Coil Mounting Bracket





81015

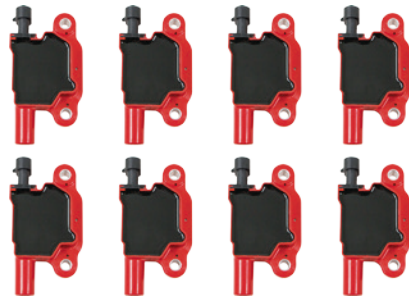

81015-8



81016



81016-8



81021



81024



81005



81022



81023



81020



TSP LS COILS

- Magnetic steel cores specially designed to deliver 15% more spark than stock
- Shock and vibration resistant epoxy able to tolerate high temperatures
- Optimized winding
- Direct OEM replacement

81015

LS2/LS3/LS7/LS9 Car Performance Ignition Coil
Red

81015-8

LS2/LS3/LS7/LS9 Car Performance Ignition Coils - 8pc/Set
Red

81016

LS2 Truck Performance Ignition Coil
Red

81016-8

LS2 Truck Performance Ignition Coils - 8pc/Set
Red

81021

LS Ignition Coil Extension Cable
24" length

81024

LS Ignition Coil Relocation Harness 12" length

81005

LS1/LS6 Billet Aluminum Ignition Coil Mounting Bracket
Natural

81022

LS Car Billet Aluminum Ignition Coil Mounting Bracket
Black, Natural

81023

LS Truck Billet Aluminum Ignition Coil Mounting Bracket
Black, Natural

81020

LS Aluminum Remote Ignition Coil Mounting Bracket
Black, Natural

LS RELOCATION BRACKETS

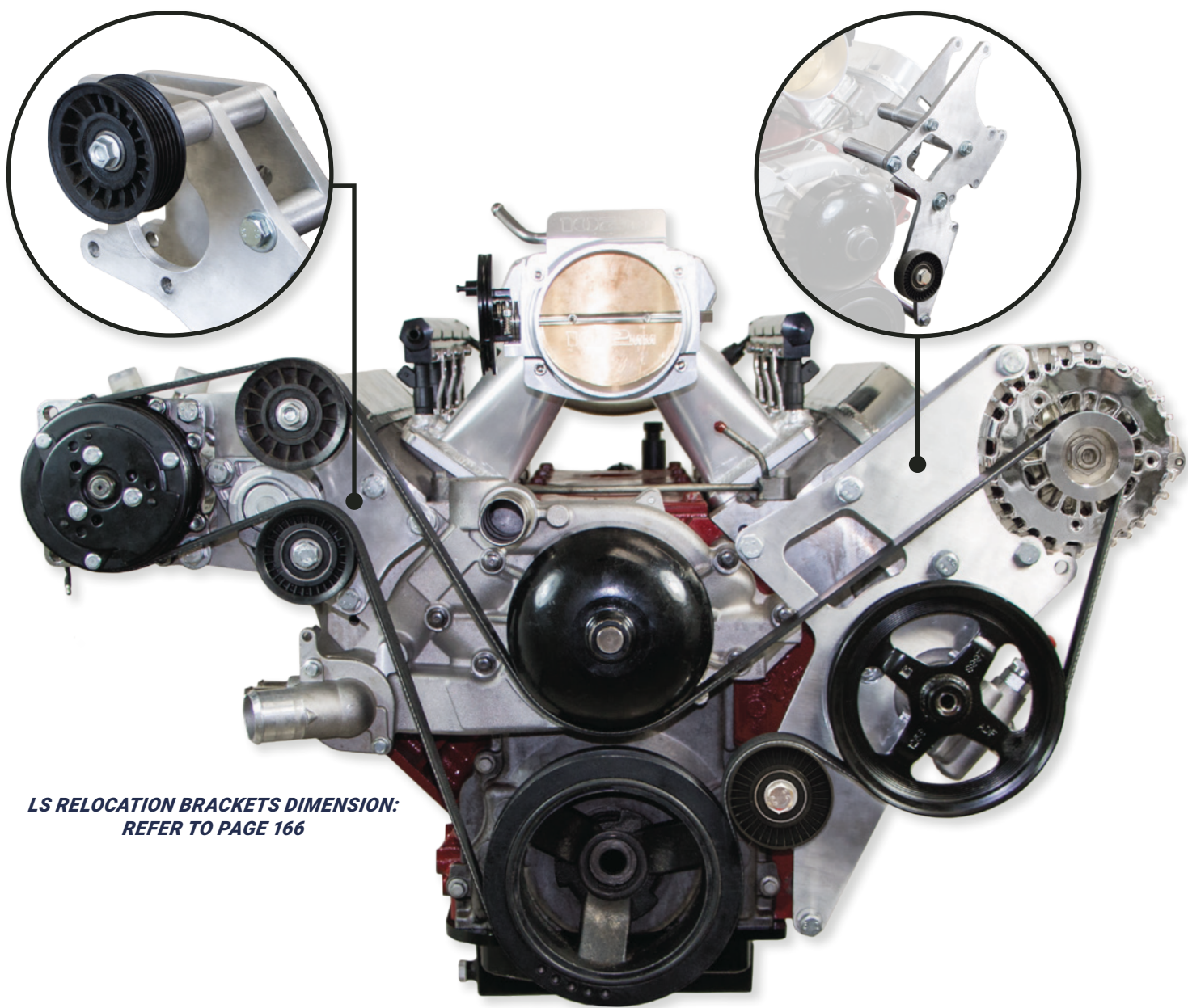

**LS RELOCATION BRACKETS DIMENSION:
REFER TO PAGE 166**

TSP's LS relocation brackets raise the engine accessories to clear the way for a more narrow frame. Composed of high-quality, lightweight aluminum, these brackets are ideal for any LS engine where space is an issue. They are all offered in natural and black finishes to complete any look.



81201

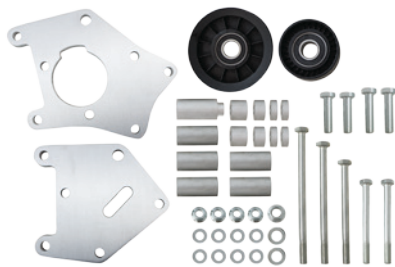

81202



81203

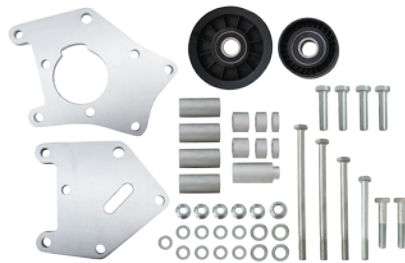

81204



12569301



12560344



12568997



LS RELOCATION BRACKETS

81201

TSP LS1/LS2 '98-'02 Camaro and Firebird/GTO, Alternator & Power Steering Pump Relocation Bracket, Brushed Aluminum
Black, Natural

81202

TSP LS1/LS2 '98-'02 Camaro and Firebird/GTO, A/C Compressor Relocation Bracket, Brushed Aluminum
Black, Natural

81203

TSP LS Truck '99+/Gen 5 Camaro 2010+ Alternator & Power Steering Pump Relocation Bracket, Brushed Aluminum
Black, Natural

81204

TSP LS Truck '99+/Gen 5 Camaro 2010+ A/C Compressor Relocation Bracket, Brushed Aluminum
Black, Natural

12569301

ACDelco Drive Belt Tensioners

12560344

ACDelco Drive Belt Tensioners

12568997

GM Power Steering Pulley
Black

* OEM Replacement

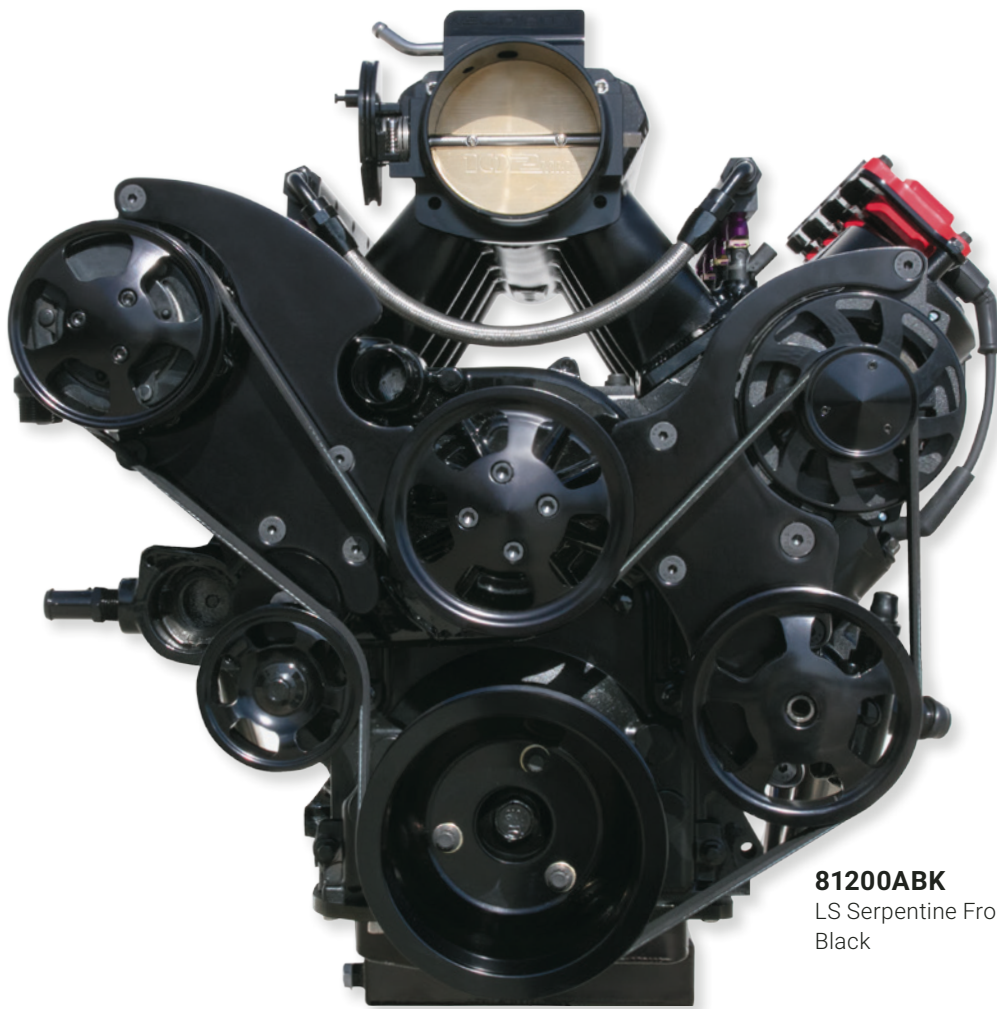

81200ABK
LS Serpentine Front Drive System
Black

81200 PATENT PENDING

LS SERPENTINE FRONT DRIVE SYSTEM INCLUDES:

- 6061-T6 Billet Aluminum Brackets
- ES1006: GM CS130 Alternator, 160 AMP
- HC5005: Sanden SD-7 Style A/C Compressor
- HC5100: A/C Compressor Manifold
- JM2010: GM Type II Power Steering Pump
- HC8936: TSP LS Customized Aluminum Mechanical Water Pump
- Custom Designed Billet Aluminum Tensioner
- 6061-T6 Billet Aluminum Pulleys
- 81102: TSP LS SFI Certified Harmonic Balancer Steel Damper
- K060675: Serpentine Belt
- Step by Step Instructions

Available in: Black, Polished

** Will not work with variable valve timing engines*

** NOT for hydroboost engines*

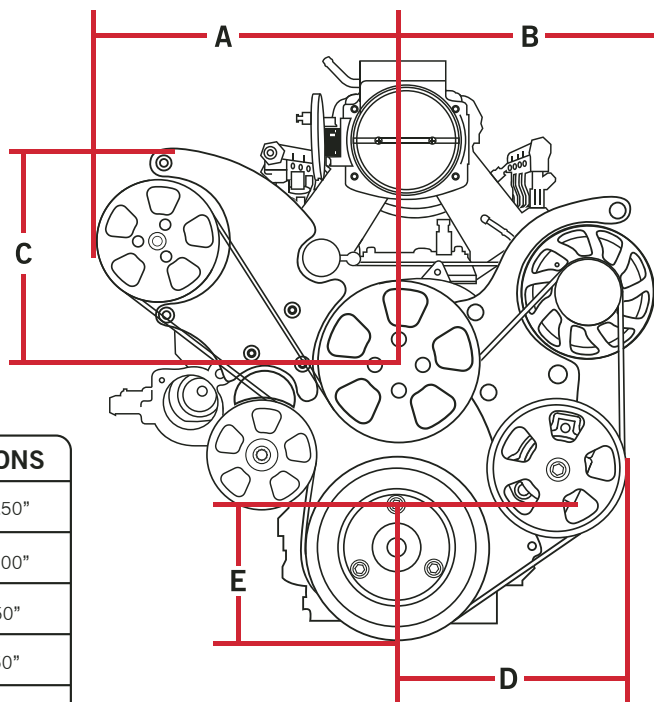

TO FRONT FACE OF	FROM BLOCK FACE	DIMENSIONS
A/C COMPRESSOR COVER	7.75"	PART A: 11.50"
ALTERNATOR PULLEY	6.85"	PART B: 10.00"
WATER PUMP PULLEY	7.00"	PART C: 7.50"
POWER STEERING PULLEY	6.50"	PART D: 8.50"
CRANKSHAFT PULLEY	6.50"	PART E: 5.00"

81200X PATENT PENDING**LS SERPENTINE FRONT DRIVE SYSTEM WITH INTEGRAL POWER STEERING RESERVOIR**

- 6061-T6 Billet Aluminum Brackets
- ES1006: GM CS130 Alternator, 160 AMP
- HC5005: Sanden SD-7 Style A/C Compressor
- HC5100: A/C Compressor Manifold
- JM2011: GM Type II Power Steering Pump with Reservoir
- HC8936: TSP LS Customized Aluminum Mechanical Water Pump
- Custom Designed Billet Aluminum Tensioner
- 6061-T6 Billet Aluminum Pulleys
- 81102: TSP LS SFI Certified Harmonic Balancer Steel Damper
- K060675: Serpentine Belt
- Step by Step Instructions

Available in: Black, Polished

** Will not work with variable valve timing engines*

** NOT for hydroboost engines*

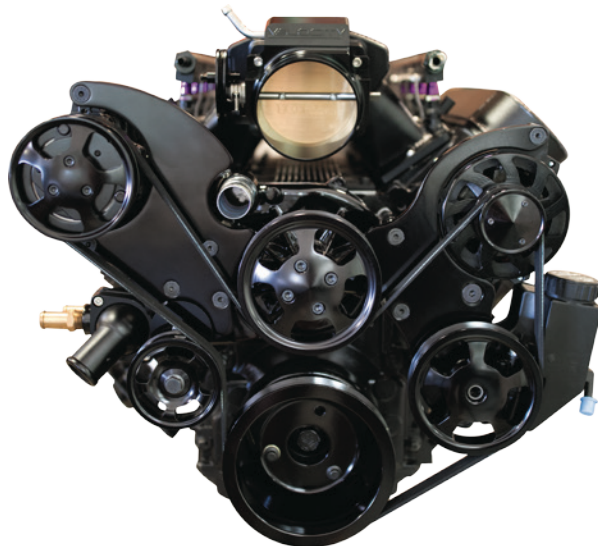
**81210** PATENT PENDING**LS SERPENTINE FRONT DRIVE SYSTEM, NO A/C**

- 6061-T6 Billet Aluminum Brackets
- ES1006: GM CS130 Alternator, 160 AMP
- JM2010: GM Type II Power Steering Pump
- HC8936: TSP LS Customized Aluminum Mechanical Water Pump
- Custom Designed Billet Aluminum Tensioner
- 6061-T6 Billet Aluminum Pulleys
- 81102: TSP LS SFI Certified Harmonic Balancer Steel Damper
- K060535: Serpentine Belt
- Step by Step Instructions

Available in: Black, Polished

** Will not work with variable valve timing engines*

** NOT for hydroboost engines*

**81211** PATENT PENDING**LS SERPENTINE FRONT DRIVE SYSTEM WITH INTEGRAL POWER STEERING RESERVOIR, NO A/C**

- 6061-T6 Billet Aluminum Brackets
- ES1006: GM CS130 Alternator, 160 AMP
- JM2011: GM Type II Power Steering Pump with Reservoir
- HC8936: TSP LS Customized Aluminum Mechanical Water Pump
- Custom Designed Billet Aluminum Tensioner
- 6061-T6 Billet Aluminum Pulleys
- 81102: TSP LS SFI Certified Harmonic Balancer Steel Damper
- K060535: Serpentine Belt
- Step by Step Instructions

Available in: Black, Polished

** Will not work with variable valve timing engines*

** NOT for hydroboost engines*



FORD COYOTE 5.0L

VALVE COVER

- Fabricated Aluminum
- Hardware, Gasket and Dipstick Included

FABRICATED INTAKE MANIFOLD

- 90mm Throttle Body Opening
- Fabricated Aluminum
- Embossed Design
- 6 in. Intake Runners

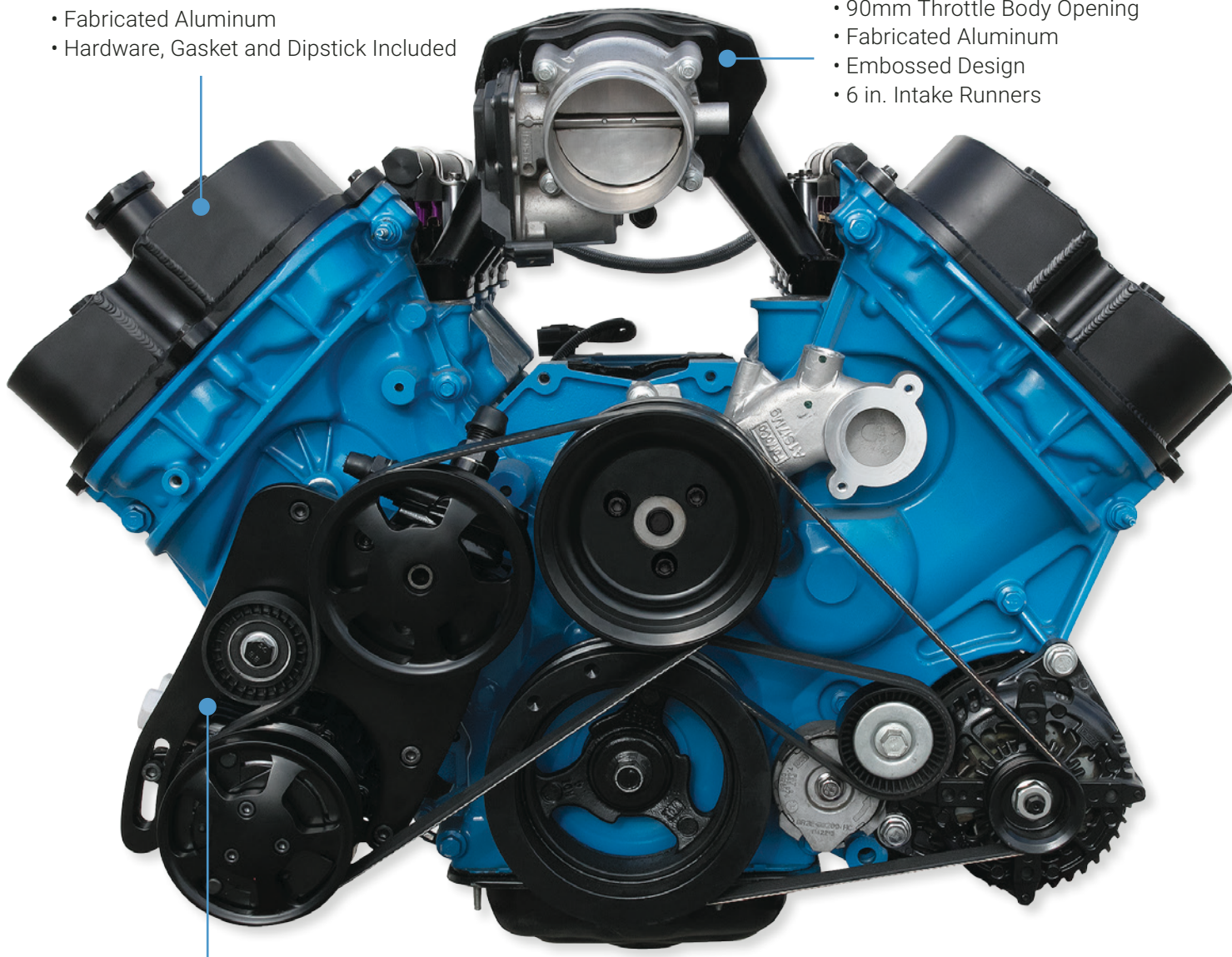

POWER STEERING KIT

- SD-7 A/C Compressor
- GM Type II Power Steering Pump
- Hardware and Bracket Included
- Idler Pulley

IGNITION COIL

- 45,000 Volts
- Primary Resistance: 760 ohms
- Spark Duration: 1.8 ms



84050



84051



84052



84053

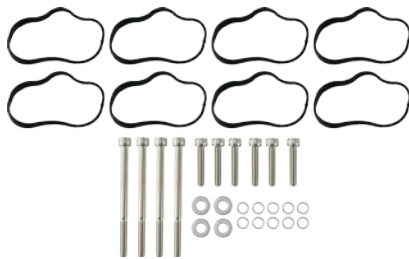

84750



JM6809-8



FORD COYOTE 5.0L

84050

Velocity® 2011+ Ford Coyote 5.0L Embossed, EFI Fabricated Aluminum Intake Manifold
Black, Clear Anodized

84051

Velocity® Ford Coyote 5.0L Billet Aluminum Fuel Rail Kit
Black

84052

Ford Coyote 5.0L Fabricated Aluminum Valve Cover, Perimeter Bolt, Oil Filler Hole,
[Patent # D875140](#)
Black, Polished

84053

Ford Coyote 5.0L Hydraulic Power Steering Kit,
[Patent # D875002](#)
Black, Polished

*Water pump pulley not shown

84750

84050 Replacement Gaskets and Mounting Bolts

JM6809-8

Ford Coyote 5.0L 2011-2016 V8 Engine Ignition Coil, 45K Volt, 8pc/Set
Blue

FORD COYOTE 5.0L VALVE COVER

- Fabricated Aluminum
- One-Piece Billet Aluminum Mounting Surface
- Rubber Grommets
- CNC Machined Oil Filler Cap
- Hardware and Gasket Included
- Dipstick

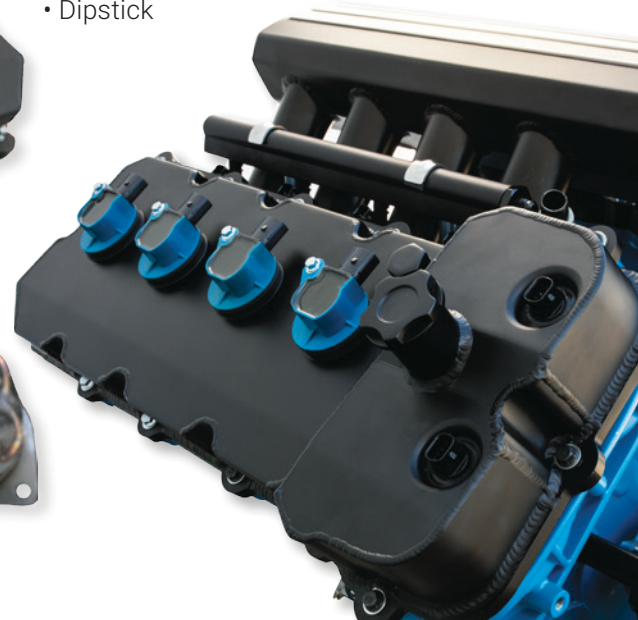



TE

FRONT DRIVE



E SYSTEMS

DS35012: SBC FRONT DRIVE SYSTEM

- HC8012 : Mechanical Water Pump, Long Style
- ES1001 : Alternator, V-Belt, 110 AMP
- JM2000 : Saginaw Power Steering Pump
- JM9101 : Alternator Brackets
- JM9105 : Power Steering Brackets
- SP8857 : Double Groove Crankshaft Pulley
- SP8854 : Single Groove Water Pump Pulley
- SP8848 : Single Groove Power Steering Pulley

Available in: Black, Chrome

*Note: Bolts and Belt Not Included

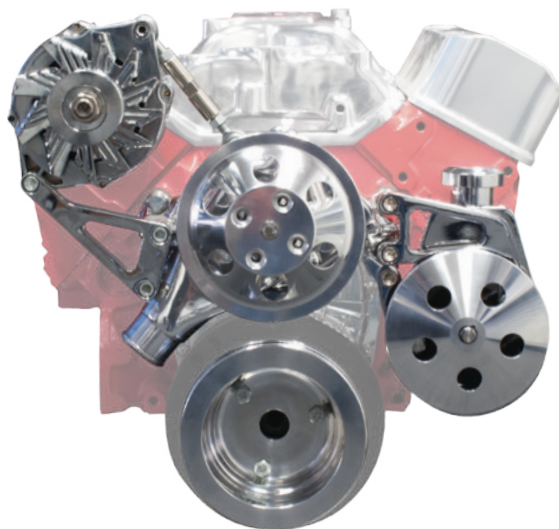
**DS35012-1: SBC FRONT DRIVE SYSTEM W/ JM9105-1 BRACKET**

- HC8012 : Mechanical Water Pump, Long Style
- ES1001 : Alternator, V-Belt, 110 AMP
- JM2000 : Saginaw Power Steering Pump
- JM9101 : Alternator Brackets
- JM9105-1 : Power Steering Brackets
- SP8857 : Double Groove Crankshaft Pulley
- SP8854 : Single Groove Water Pump Pulley
- SP8848 : Single Groove Power Steering Pulley

Available in: Black, Chrome

*Note: Bolts and Belt Not Included

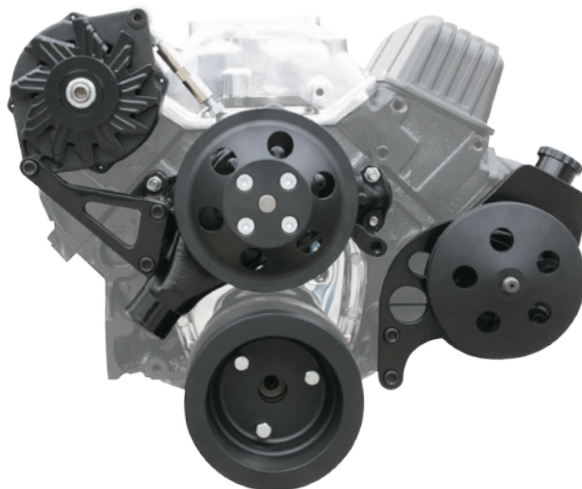
**DS35014: SBC SERPENTINE FRONT DRIVE SYSTEM**

- HC8014 : Reverse Rotation Mechanical Water Pump, Long Style
- ES1006 : Alternator w/ Side Battery Post, Serpentine Belt, 160 AMP
- ES1005W: Alternator Wire
- HC5005 : A/C Compressor Sanden SD-7 Style, Serpentine Belt
- JM2010 : GM Type II Power Steering Pump, -10AN Inlet, -6AN Outlet
- 85000 : Chevy SB Accessory Plates
- 85001 : Chevy SB Serpentine Pulley
- 85003 : Tensioner
- HW1490 : Hardware/Spacer
- Belt no. K060650

Available in: Black, Polished

*Note: Bolts Included



DS35014X: SBC SERPENTINE FRONT DRIVE SYSTEM WITH INTEGRAL POWER STEERING RESERVOIR

- HC8014 : Reverse Rotation Mechanical Water Pump, Long Style
- ES1006 : Alternator w/ Side Battery Post, Serpentine Belt, 160 AMP
- ES1005W: Alternator Wire
- HC5005 : A/C Compressor Sanden SD-7 Style, Serpentine Belt
- JM2011 : GM Type II Power Steering Pump with Reservoir
- 85000 : Chevy SB Accessory Plates
- 85001 : Chevy SB Serpentine Pulley
- 85003 : Tensioner
- HW1490 : Hardware/Spacer
- Belt no. K060650

Available in: Black, Polished

*Note: Bolts Included



DS45422: BBC FRONT DRIVE SYSTEM

- HC8022 : Mechanical Water Pump, Long Style
- ES1001 : Alternator, V-Belt, 110 AMP
- JM2000 : Saginaw Power Steering Pump
- JM9103 : Alternator Brackets
- JM9115 : Power Steering Brackets
- SP8839 : Double Groove Crankshaft Pulley
- SP8838 : Double Groove Water Pump Pulley
- SP8848 : Single Groove Power Steering Pulley

Available in: Black, Chrome

*Note: Bolts and Belt Not Included



DS45423: BBC SERPENTINE FRONT DRIVE SYSTEM

- HC8023 : Reverse Rotation Mechanical Water Pump, Short Style
- ES1006 : Alternator w/ Side Battery Post, Serpentine Belt, 160 AMP
- ES1005W: Alternator Wire
- HC5005 : A/C Compressor Sanden SD-7 Style, Serpentine Belt
- JM2010 : GM Type II Power Steering Pump, -10AN Inlet, -6AN Outlet
- 85001 : Chevy BB Serpentine Pulley
- 86000 : Chevy BB Accessory Plates
- 86001 : Chevy BB Spacers
- 85003 : Tensioner
- HW2390 : Hardware/Spacer
- Belt no. K060680

Available in: Black, Polished

*Note: Bolts Included



DS45423X: BBC SERPENTINE FRONT DRIVE SYSTEM WITH INTEGRAL POWER STEERING RESERVOIR

- HC8023 : Reverse Rotation Mechanical Water Pump, Short Style
- ES1006 : Alternator w/ Side Battery Post, Serpentine Belt, 160 AMP
- ES1005W: Alternator Wire
- HC5005 : A/C Compressor Sanden SD-7 Style, Serpentine Belt
- JM2011 : GM Type II Power Steering Pump with Reservoir
- 85001 : Chevy BB Serpentine Pulley
- 86000 : Chevy BB Accessory Plates
- 86001 : Chevy BB Spacers
- 85003 : Tensioner
- HW2390 : Hardware/Spacer
- Belt no. K060680

Available in: Black, Polished

*Note: Bolts Included



DS35001: SBC FRONT DRIVE SYSTEM, LONG WATER PUMP, HIGH MOUNT ALTERNATOR BRACKET

- HC8012 : Chevy SB Mechanical Water Pump, Long Style
- ES1001 : Alternator, V-Belt, 110 AMP
- JM9121 : High Mount Alternator Bracket Kit
- 10091 : Chevy SB Gilmer Style Pulley Kit, Long Water Pump

Available in: Black, Chrome

*Note: Bolts and Belt Included

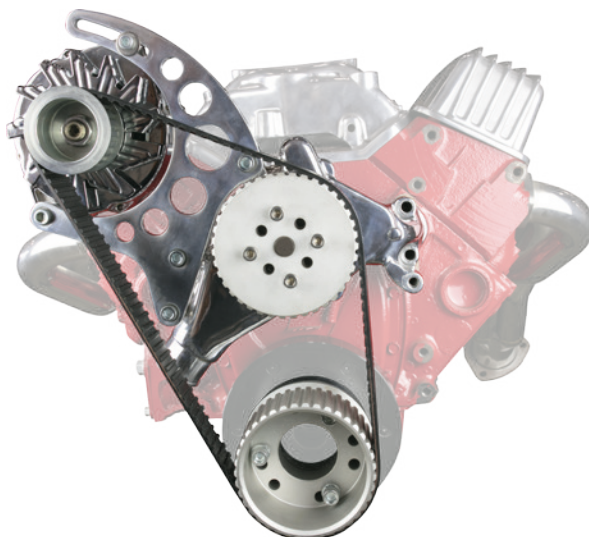

DS35002: SBC FRONT DRIVE SYSTEM, LONG WATER PUMP, MID MOUNT ALTERNATOR BRACKET

- HC8012 : Chevy SB Mechanical Water Pump, Long Style
- ES1001 : Alternator, V-Belt, 110 AMP
- JM9131 : Mid Mount Alternator Bracket Kit
- 10091 : Chevy SB Gilmer Style Pulley Kit, Long Water Pump
- 10088 : Chevy SB/BB Gilmer Style Drive 5/8" Crankshaft Spacer with 2-3/4" Bolt Kit

Available in: Black, Chrome

*Note: Bolts and Belt Included

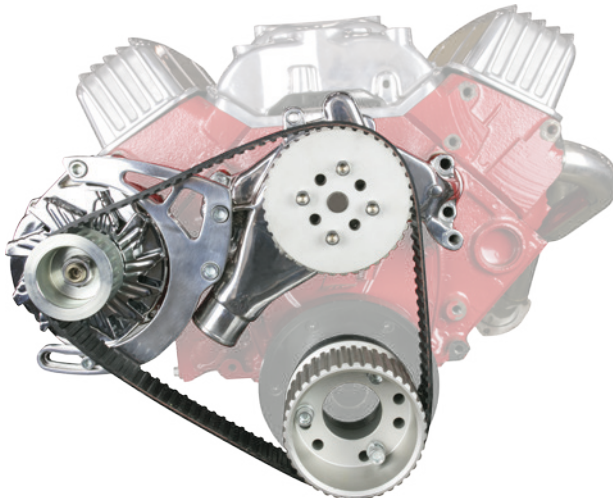

DS35003: SBC FRONT DRIVE SYSTEM, SHORT WATER PUMP, LOW MOUNT ALTERNATOR BRACKET, DRIVER SIDE

- HC8011 : Chevy SB Mechanical Water Pump, Short Style
- ES1001 : Alternator, V-Belt, 110 AMP
- SP6079 : Low Mount Alternator Bracket Kit
- 10090 : Chevy SB Gilmer Style Pulley Kit, Short Water Pump
- 10088 : Chevy SB/BB Gilmer Style Drive 5/8" Crankshaft Spacer with 2-3/4" Bolt Kit

Available in: Chrome

*Note: Bolts and Belt Included

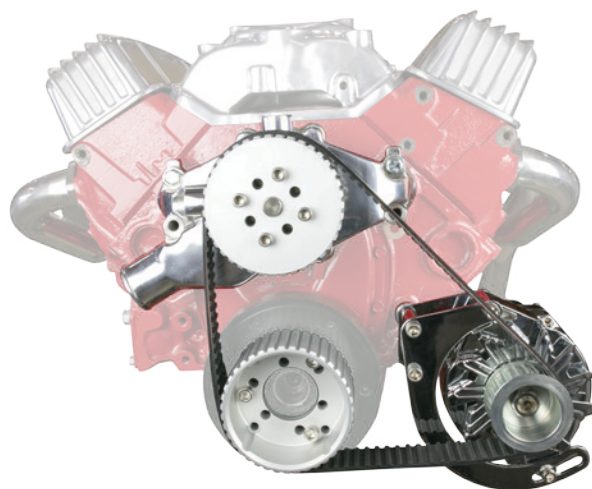

DS45404: BBC FRONT DRIVE SYSTEM, LONG WATER PUMP, HIGH MOUNT ALTERNATOR BRACKET

- HC8022 : Chevy BB Mechanical Water Pump, Long Style
- ES1001 : Alternator, V-Belt, 110 AMP
- JM9123 : Chevy BB High Mount Alternator Bracket Kit
- 10092 : Chevy BB Gilmer Style Pulley Kit, Long Water Pump

Available in: Black, Chrome

*Note: Bolts and Belt Included

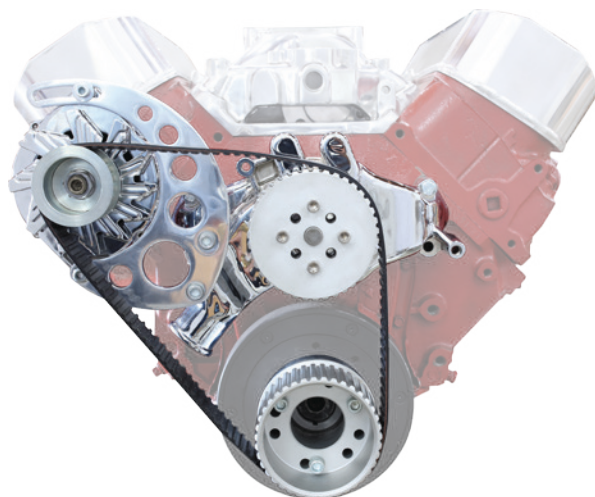

DS45405: BBC FRONT DRIVE SYSTEM, LONG WATER PUMP, MID MOUNT ALTERNATOR BRACKET

- HC8022 : Chevy BB Mechanical Water Pump, Long Style
- ES1001 : Alternator, V-Belt, 110 AMP
- JM9133 : Chevy BB Mid Mount Alternator Bracket Kit
- 10092 : Chevy BB Gilmer Style Pulley Kit, Long Water Pump
- 10088 : Chevy SB/BB Gilmer Style Drive 5/8" Crankshaft Spacer with 2-3/4" Bolt Kit

Available in: Black, Chrome

*Note: Bolts and Belt Included

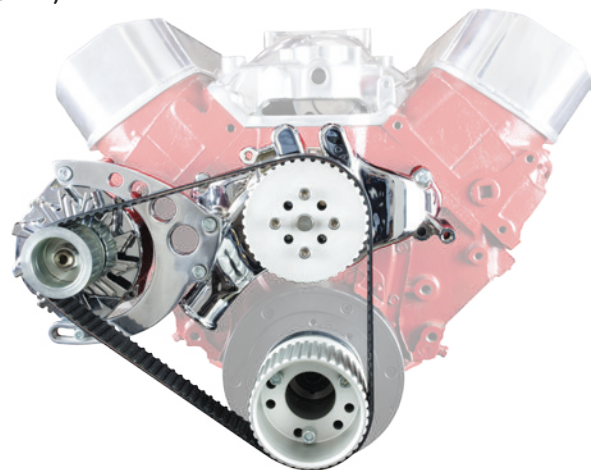

PRO SERIES PRO BILLET DISTRIBUTORS



Fully adjustable mechanical advance

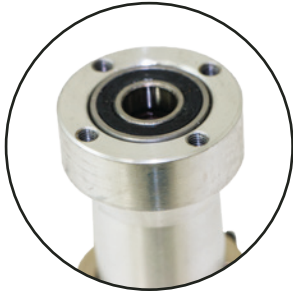

Ball bearing supported shaft for stability up to 10,000 RPM



Adjustable collar for decked blocks*
**JM7601 and JM7601-1 Only*



Precision CNC machined body



TSP's Pro Series Pro Billet Distributor is for the racer who needs added spark and precision for their high performance power plant. It features a high quality, fully adjustable mechanical advance and an accurate magnetic pickup trigger. The CNC-machined aluminum body and hardened steel shaft, guided by a sealed ball bearing on top and a sintered steel bushing on the bottom, ensure stability up to 10,000 RPM. The dielectric cap features bolt-down and twist-lock capabilities. It has solid brass terminals and comes with a color-matched wire retainer.

Requires a capacitive discharge ignition (CDI) system (See Page 53-54)

JM7601

Chevy SB/BB V8 Engine
Pro Series Pro Billet Distributor

INSTALLATION: REFER TO PAGE 153



JM7601-1*



JM9601



JM7602



JM7603



JM7604



JM7606



JM7608



JM7609



JM7610



JM7613



PRO SERIES PRO BILLET DISTRIBUTORS

Requires a capacitive discharge ignition (CDI) system (Page 53-54)

JM7601*

Chevy SB/BB V8 Engine
Pro Series Pro Billet Distributor
Black, Red

JM7601-1* (with Vacuum Advance)

Chevy SB/BB V8 Engine
Pro Series Pro Billet Distributor with Vacuum Advance
Black, Red

JM9601 (Short Cap)

Chevy SB/BB V8 Engine Short Cap
Pro Series Pro Billet Distributor
Black, Red

JM7602

Ford SB 289/302 V8 Engine
Pro Series Pro Billet Distributor
Black, Blue, Red

JM7603

Oldsmobile SB/BB V8 Engine
Pro Series Pro Billet Distributor
Black, Red

JM7604

Pontiac SB/BB V8 Engine
Pro Series Pro Billet Distributor
Black, Red

JM7606

Ford 351 Cleveland/Ford BB 429-460 V8 Engine Pro Series Pro Billet Distributor
Black, Blue, Red

JM7608

Ford FE V8 Engine Pro Series Pro Billet Distributor
Black, Blue, Red

JM7609

Chevy 348/409 V8 Engine
Pro Series Pro Billet Distributor
Black, Red

JM7610

Ford 351 Windsor V8 Engine
Pro Series Pro Billet Distributor
Black, Blue, Red

JM7613

Mopar SB 273/318/340/360 V8 Engine
Pro Series Pro Billet Distributor
Black, Red

*Will not work if it uses a governor

JM7614**

Mopar BB 413/426/440 V8 Engine
Pro Series Pro Billet Distributor
Black, Red



JM7614**



JM7619**



JM7619**

Mopar BB 383/400 V8 Engine
Pro Series Pro Billet Distributor
Black, Red

JM7637

Holden 253/304/308
Pro Series Pro Billet Distributor
Black, Red



JM7637



JM7650

Volkswagen Beetle 1.3
Pro Series Pro Billet Distributor
Red



JM7650



**Will not fit fabricated valve covers

POWER PACK IGNITION KIT

TSP's Power Pack Ignition Kit delivers our best ignition components, all in one retail-friendly display box. It includes our Pro Series Pro Billet distributor, our 50,000 volt E-Core ignition coil, and our 6AL style digital ignition box. This performance ignition kit is perfect for street and strip.



JM7601R
Pro Series Pro Billet Distributor

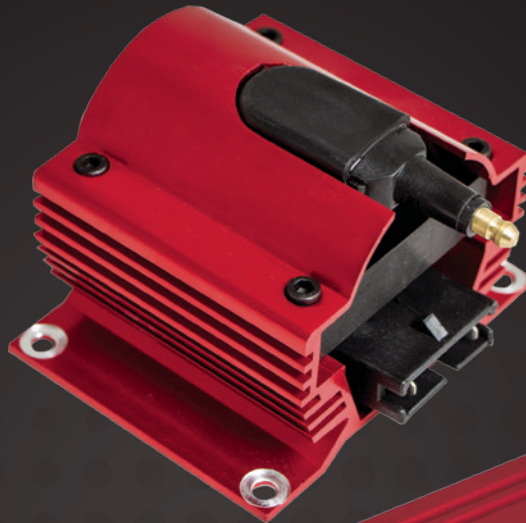

JM6930R
External E-Core Ignition Coil



JM6931R
Pro Series Digital 6AL Power Box

POWER PACK IGNITION KIT	APPLICATION
JM7901BK-KT / JM7901R-KT	Chevy SB/BB
JM7901-1BK-KT / JM7901-1R-KT	Chevy SB/BB (with Vacuum Advance)
JM7902BK-KT / JM7902BL-KT / JM7902R-KT	Ford SB 289/302
JM7903BK-KT / JM7903R-KT	Oldsmobile SB/BB
JM7904BK-KT / JM7904R-KT	Pontiac SB/BB
JM7906BK-KT / JM7906BL-KT / JM7906R-KT	Ford 351 Cleveland / Ford BB 429-460
JM7908BK-KT / JM7908BL-KT / JM7908R-KT	Ford FE
JM7909BK-KT / JM7909R-KT	Chevy 348/409
JM7910BK-KT / JM7910BL-KT / JM7910R-KT	Ford 351 Windsor
JM7913BK-KT / JM7913R-KT	Mopar SB 273/318/340/360
JM7914BK-KT / JM7914R-KT	Mopar BB 413/426/440
JM7919BK-KT / JM7919R-KT	Mopar BB 383/400
JM7937BK-KT / JM7937R-KT	Holden 253/304/308
JM7950R-KT	Volkswagen Beetle 1.3

PRO SERIES READY TO RUN DISTRIBUTORS



Fully adjustable mechanical advance

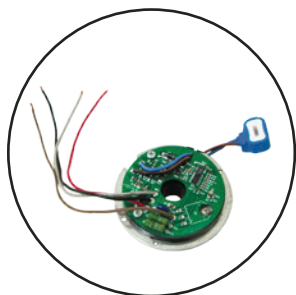

High output circuit board module with digital tach output

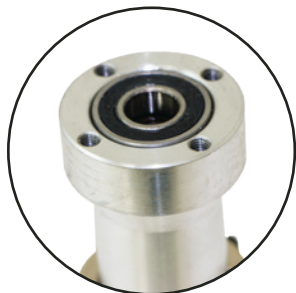

Ball bearing supported shaft for stability up to 10,000 RPM

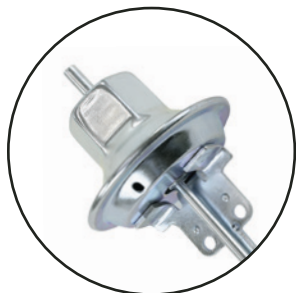

Adjustable vacuum advance canister

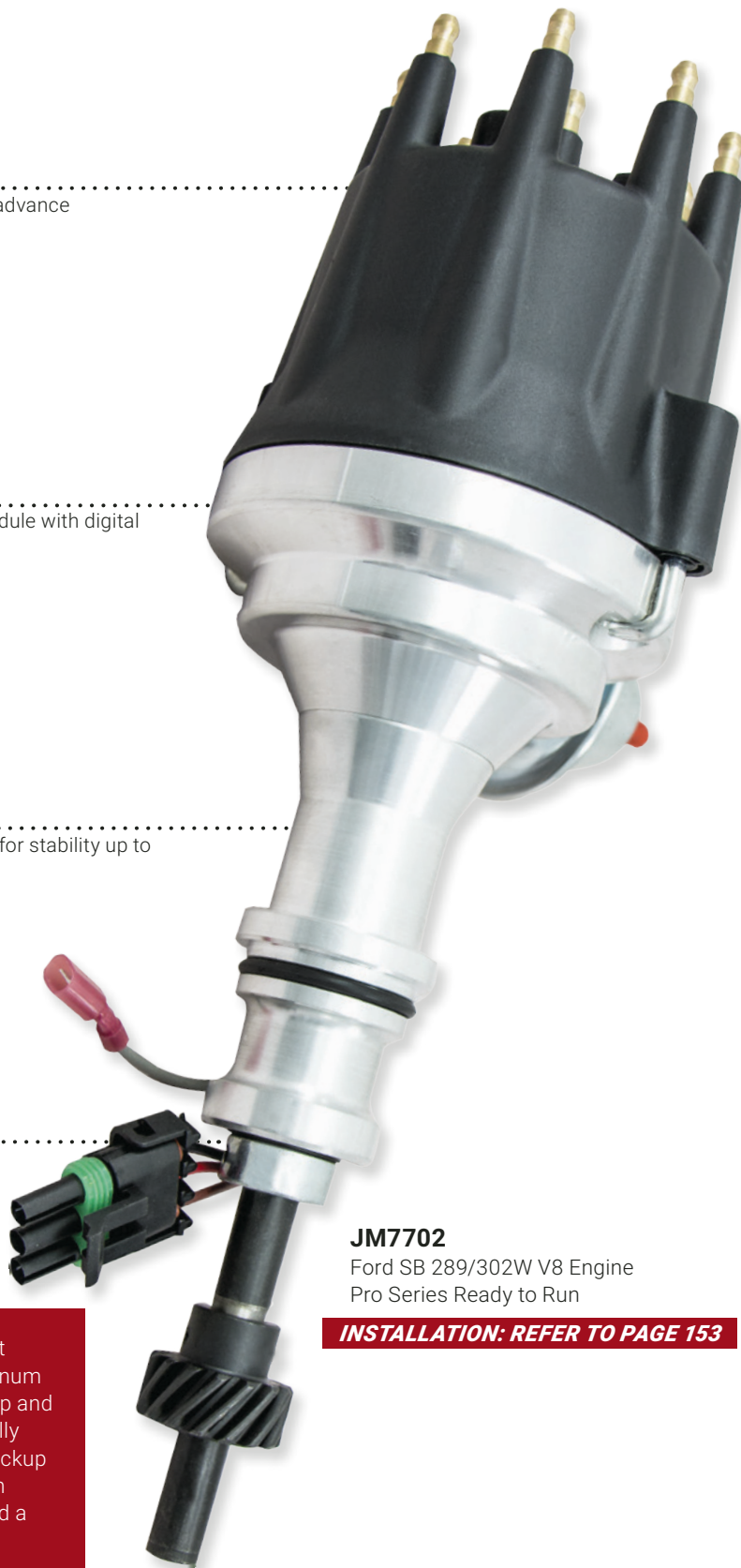

JM7702

Ford SB 289/302W V8 Engine
Pro Series Ready to Run

INSTALLATION: REFER TO PAGE 153

TSP's Pro Series Ready to Run Distributor is perfect for a street performance upgrade. It features a CNC-machined billet aluminum body and hardened steel shaft, with a sealed ball bearing on top and a sintered steel bushing on the bottom. It also comes with a fully adjustable mechanical advance, vacuum advance, magnetic pickup trigger, and a high-output circuit board module with digital tach output. The dielectric cap comes with solid brass terminals and a color-matched wire retainer.



JM7701*



JM7701-2*



JM7702-5



JM7703



JM7704



JM7706



JM7708



JM7709



JM7710



JM7710-5



PRO SERIES READY TO RUN DISTRIBUTORS

Must connect tach to negative side of the coil if exceeding 6000 RPM, Recommended use JM6930 coil.

JM7701* (Adjustable Collar)

Chevy SB/BB V8 Engine Pro Series Ready to Run Distributor, Adjustable Collar
Black, Blue, Red

JM7701-2* (Fixed Collar)

Chevy SB/BB V8 Engine Pro Series Ready to Run Distributor, Fixed Collar
All Black, Black, Red

JM7702

Ford SB 289/302 V8 Engine
Pro Series Ready to Run Distributor
All Black, Black, Blue, Red

JM7702-5

Ford SB 302 V8 Engine, 5.0L EFI to Carb
Pro Series Ready to Run Distributor
Black, Blue, Red

JM7703

Oldsmobile SB/BB V8 Engine
Pro Series Ready to Run Distributor
Black, Red

JM7704

Pontiac SB/BB V8 Engine
Pro Series Ready to Run Distributor
Black, Red

JM7706

Ford 351 Cleveland/Ford BB 429-460
V8 Engine Pro Series Ready to Run
Distributor
All Black, Black, Blue, Red

JM7708

Ford FE 352/360/390/427/428 V8 Engine
Pro Series Ready to Run Distributor
All Black, Black, Blue, Red

JM7709

Chevy 348-409 V8 Engine
Pro Series Ready to Run Distributor
Black, Red

JM7710

Ford 351 Windsor V8 Engine
Pro Series Ready to Run Distributor
All Black, Black, Blue, Red

JM7710-5

Ford 351 Windsor V8 Engine, 5.8L EFI to
Carb Pro Series Ready to Run Distributor
Black, Blue, Red

*Will not work if it uses a governor

JM7711

AMC/Jeep 232-258 I6 Engine
Pro Series Ready to Run Distributor
Black, Red

**JM7711****JM7712****JM7712**

AMC/Jeep 290-401 V8 Engine
Pro Series Ready to Run Distributor
Black, Red

JM7713

Mopar SB 273/318/340/360 V8 Engine
Pro Series Ready to Run Distributor
Black, Red

**JM7713****JM7714******JM7714****

Mopar BB 413/426/440 V8 Engine
Pro Series Ready to Run Distributor
Black, Red

JM7715

1962-1974 Chevy Corvette SB/BB
Tach Drive V8 Engine
Pro Series Ready to Run Distributor
Black, Red

**JM7715****JM7716****JM7716**

1941-1962 Early Chevy 194/216/235,
1968-1987 Toyota Land Cruiser F 2F,
I6 Engine Pro Series Ready to Run
Distributor
Black, Red

JM7717

Cadillac 472/500 V8 Engine
Pro Series Ready to Run Distributor
Black, Red

**JM7717****JM7718****JM7718**

Mopar Slant-6 Engine
Pro Series Ready to Run Distributor
Black, Red

JM7719**

Mopar BB 383/400 V8 Engine
Pro Series Ready to Run Distributor
Black, Red

JM7721

Chevy V6 Engine Pro Series
Ready to Run Distributor
Black, Red

**JM7719******JM7721**

**Will not fit fabricated valve covers



JM7723



JM7724



JM7725



JM7727



JM7728



JM7730



JM7731



JM7732



JM7733



JM7734

**JM7723**

Chevy 230/250/292 I6 Engine
Pro Series Ready to Run Distributor
Black, Red

JM7724

Buick SB V8 Engine Pro Series
Ready to Run Distributor
Black, Red

JM7725

Buick BB V8 Engine Pro Series
Ready to Run Distributor
Black, Red

JM7727

Ford 170/200/250 I6 Engine 5/16 Hex
Shaft Pro Series Ready to Run Distributor
Black, Blue, Red

JM7728

Ford 240/300 I6 Engine
Pro Series Ready to Run Distributor
Black, Blue, Red

JM7730

Early Hemi Mopar 392 Engine
Pro Series Ready to Run Distributor
Black, Red

JM7731

Early Hemi Mopar 331/354 Engine
Pro Series Ready to Run Distributor
Black, Red

JM7732

Chevy Corvair Flat 6 Engine
Pro Series Ready to Run Distributor
Black, Red

JM7733

1951-1964 Studebaker V8 Engine
Pro Series Ready to Run Distributor
Black, Red

JM7734

1949-1962 Early Cadillac 331/365/390
V8 Engine Pro Series Ready to Run
Distributor
Black, Red

JM7735

Buick Nailhead 322-425 V8 Engine
Pro Series Ready to Run Distributor
Black, Red



JM7735



JM7737



JM7737

Holden 253/304/308
Pro Series Ready to Run Distributor
Black, Red

JM7738

International 304/345/392 V8 Engine
Pro Series Ready to Run Distributor
Black, Red



JM7738



JM7740



JM7740

1949-1953 Ford Flathead V8 Engine
Pro Series Ready to Run Distributor
Black, Blue, Red

JM7741 (Male Cap)

1955-1957 Ford Thunderbird Y-Block
Tach Drive Pro Series Ready to Run
Distributor, Male Cap
Black, Blue, Red



JM7741



JM7742



JM7742

Ford 272/292/312 Y-Block Engine
Pro Series Ready to Run Distributor
Black, Blue, Red

JM7750

Volkswagen Beetle 1.3
Pro Series Ready to Run Distributor
Black, Blue, Red



JM7750



PRO SERIES

READY TO RUN KIT

TSP's Pro Series Ready to Run Kit is perfect for firing up your street performance machine. It's available for many applications and comes with our Pro Series Ready to Run distributor and one of our 45,000 volt oil-filled canister ignition coils.

- JM8801BK-KT / JM8801BL-KT / JM8801R-KT : Chevy SB/BB
- JM8801-2ABK-KT / JM8801-2BK-KT / JM8801-2R-KT : Chevy SB/BB, Fixed Collar
- JM8802ABK-KT / JM8802BK-KT / JM8802BL-KT / JM8802R-KT : Ford SB 302
- JM8802-5BK-KT / JM8802-5BL-KT / JM8802-5R-KT : Ford SB 302, 5.0L EFI to Carb
- JM8803BK-KT / JM8803R-KT : Oldsmobile SB/BB
- JM8804BK-KT / JM8804R-KT : Pontiac SB/BB
- JM8806ABK-KT / JM8806BK-KT / JM8806BL-KT / JM8806R-KT : Ford 351 Cleveland/Ford BB 429-460
- JM8808ABK-KT / JM8808BK-KT / JM8808BL-KT / JM8808R-KT : Ford FE 352/360/390/427/428
- JM8809BK-KT / JM8809R-KT : Chevy 348-409
- JM8810ABK-KT JM8810BK-KT / JM8810BL-KT / JM8810R-KT : Ford 351 Windsor
- JM8810-5BK-KT / JM8810-5BL-KT / JM8810-5R-KT : Ford 351 Windsor, 5.8L EFI to Carb
- JM8811BK-KT / JM8811R-KT : AMC/Jeep 232-258
- JM8812BK-KT / JM8812R-KT : AMC/Jeep 290-401
- JM8813BK-KT / JM8813R-KT : Mopar SB 273/318/340/360
- JM8814BK-KT / JM8814R-KT : Mopar BB 413/426/440
- JM8815BK-KT / JM8815R-KT : Chevy Corvette SB/BB
- JM8816BK-KT / JM8816R-KT : 1941-1962 Early Chevy 194/216/235
- JM8817BK-KT / JM8817R-KT : Cadillac 472/500
- JM8818BK-KT / JM8818R-KT : Mopar Slant-6
- JM8819BK-KT / JM8819R-KT : Mopar BB 383/400
- JM8821BK-KT / JM8821R-KT : Chevy V6
- JM8823BK-KT / JM8823R-KT : Chevy 230/250/292
- JM8824BK-KT / JM8824R-KT : Buick SB
- JM8825BK-KT / JM8825R-KT : Buick BB
- JM8827BK-KT / JM8827BL-KT / JM8827R-KT : Ford 144/200/250
- JM8828BK-KT / JM8828BL-KT / JM8828R-KT : Ford 240/300
- JM8830BK-KT / JM8830R-KT : Early Hemi Mopar 392
- JM8831BK-KT / JM8831R-KT : Early Hemi Mopar 331/354
- JM8832BK-KT / JM8832R-KT : Chevy Corvair
- JM8833BK-KT / JM8833R-KT : 1951-1964 Studebaker
- JM8834BK-KT / JM8834R-KT : Early Cadillac
- JM8835BK-KT / JM8835R-KT : Buick Nailhead 322-425
- JM8837BK-KT / JM8837R-KT : Holden 253/304/308
- JM8838BK-KT / JM8838R-KT : International 304/345/392
- JM8840BK-KT / JM8840BL-KT / JM8840R-KT : 1949-1953 Ford Flathead
- JM8841BK-KT / JM8841BL-KT / JM8841R-KT : Ford Tach Drive
- JM8842BK-KT / JM8842BL-KT / JM8842R-KT : Ford 272/292/312
- JM8850BK-KT / JM8850BL-KT / JM8850R-KT : Volkswagen Beetle 1.3



TSP
TOP STREET PERFORMANCE

HEI DISTRIBUTORS

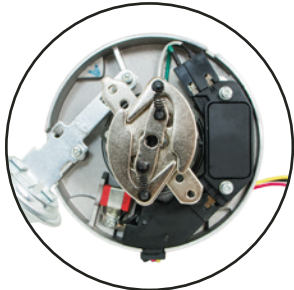

Mechanical advance

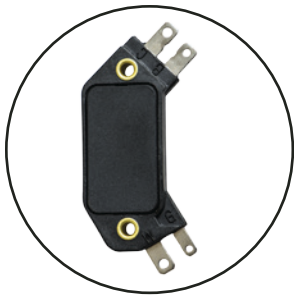

High output HEI 4 pin module

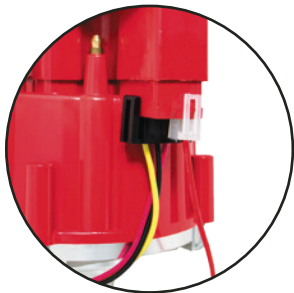

1-wire hookup

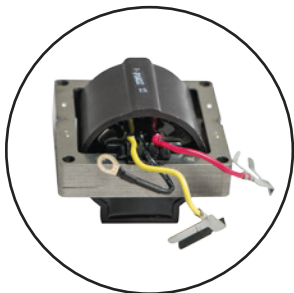

65K Volt Coil

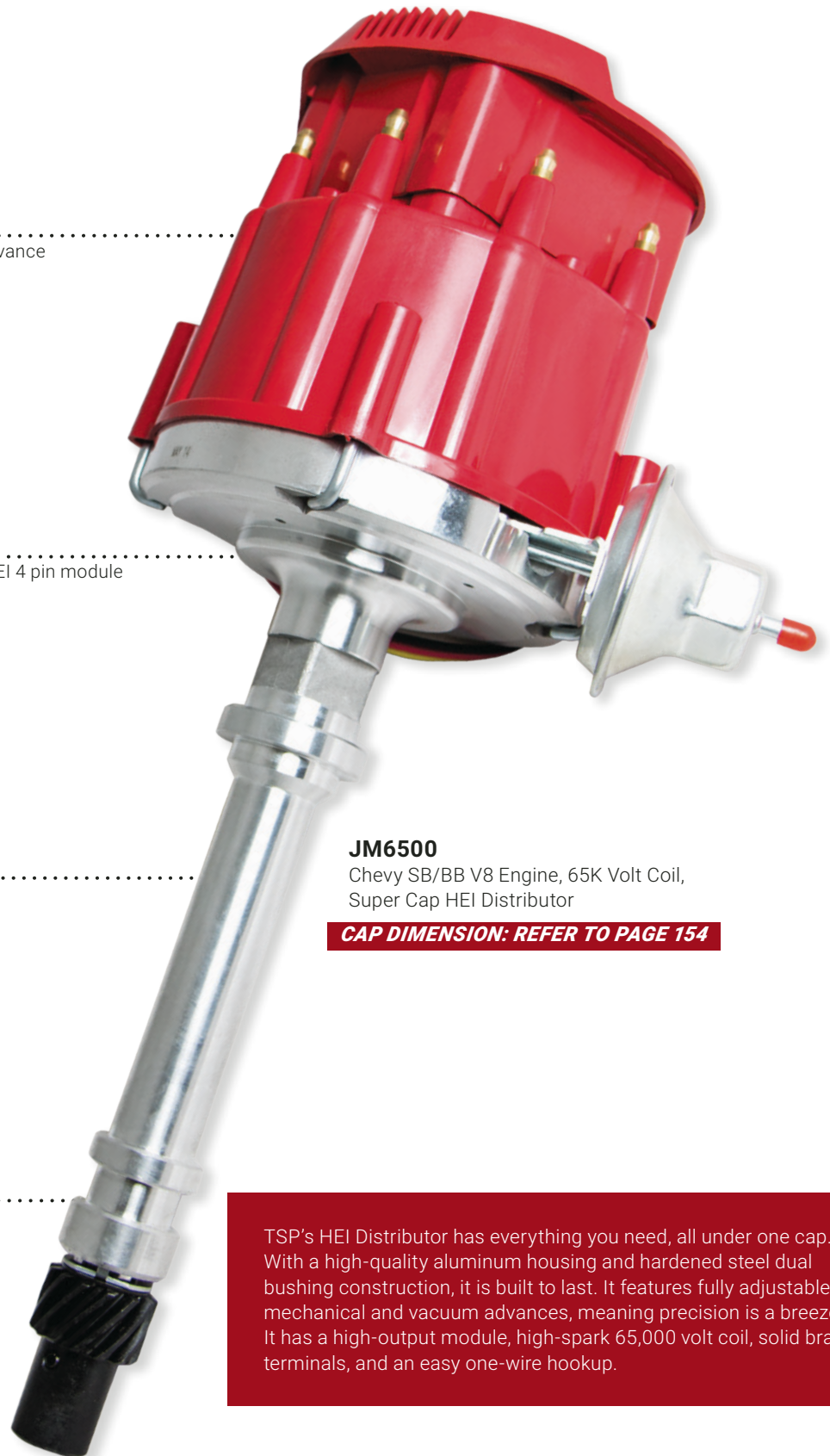

JM6500
Chevy SB/BB V8 Engine, 65K Volt Coil,
Super Cap HEI Distributor

CAP DIMENSION: REFER TO PAGE 154

TSP's HEI Distributor has everything you need, all under one cap. With a high-quality aluminum housing and hardened steel dual bushing construction, it is built to last. It features fully adjustable mechanical and vacuum advances, meaning precision is a breeze. It has a high-output module, high-spark 65,000 volt coil, solid brass terminals, and an easy one-wire hookup.



JM6501*



JM6502



JM6502-5



JM6503



JM6504



JM6506



JM6508



JM6508-5



JM6509



JM6510



HEI DISTRIBUTORS

JM6500*

Chevy SB/BB V8 Engine, 65K Volt Coil HEI Distributor, Super Cap
Black, Clear, Gray, Red

JM6501*

Chevy SB/BB V8 Engine, 65K Volt Coil HEI Distributor, OEM Cap
All Black, Black, Blue, Clear, Red, Red/Black

JM6502

Ford SB 289/302 V8 Engine, 65K Volt Coil HEI Distributor
All Black, Black, Blue, Clear, Red

JM6502-5

Ford SB 302 V8 Engine, 5.0L EFI to Carb, 65K Volt Coil HEI Distributor
Black, Blue, Red

JM6503

Oldsmobile SB/BB V8 Engine, 65K Volt Coil HEI Distributor
Black, Blue, Clear, Red

JM6504

Pontiac SB/BB V8 Engine, 65K Volt Coil HEI Distributor
Black, Blue, Clear, Red

JM6506

Ford 351 Cleveland/Ford BB 429-460 V8 Engine, 65K Volt Coil HEI Distributor
All Black, Black, Blue, Clear, Orange, Red

JM6508

Ford FE 352/360/390/427/428 V8 Engine, 65K Volt Coil HEI Distributor with 1/4 Shaft
All Black, Black, Blue, Clear, Red

JM6508-5

Ford FE 330/361/391 V8 Engine, 65K Volt Coil Heavy-Duty Truck with 5/16 Shaft
Black, Red

JM6509

Chevy 348/409 V8 Engine, 65K Volt Coil HEI Distributor
Black, Red

JM6510

Ford 351 Windsor V8 Engine, 65K Volt Coil HEI Distributor
All Black, Black, Blue, Clear, Red

*Will not work if it uses a governor

JM6510-5

Ford 351 Windsor V8 Engine,
5.8L EFI to Carb, 65K Volt Coil
HEI Distributor
Black, Blue, Red

**JM6510-5****JM6511****JM6511**

AMC/Jeep 232/258 I6 Engine,
65K Volt Coil HEI Distributor
Black, Blue, Clear, Red

JM6512

AMC/Jeep 290-401 V8 Engine,
65K Volt Coil HEI Distributor
Black, Blue, Clear, Red

**JM6512****JM6513****JM6513**

Mopar SB 273/318/340/360 V8 Engine,
65K Volt Coil HEI Distributor
Black, Blue, Orange, Red

JM6515

1962-1974 Chevy Corvette SB/BB
Tach Drive V8 Engine, 65K Volt Coil
HEI Distributor
Black, Blue, Clear, Red

**JM6515****JM6516****JM6516**

1941-1962 Early Chevy 194/216/235,
1968-1987 Toyota Land Cruiser F 2F,
I6 Engine, 65K Volt Coil HEI Distributor
Black, Clear, Red

JM6517

Cadillac 472/500 V8 Engine,
65K Volt Coil HEI Distributor
Black, Red

**JM6517****JM6520****JM6520**

Chevy V6 Engine, 65K Volt Coil
HEI Distributor, Super Cap
Black, Red

JM6521

Chevy V6 Engine, 65K Volt Coil
HEI Distributor, OEM Cap
Black, Blue, Red

**JM6521****JM6522**



JM6523



JM6524



JM6525



JM6526



JM6527



JM6528



JM6529



JM6530



JM6531



JM6535

**JM6523**

Chevy 230/250/292 I6 Engine,
65K Volt Coil HEI Distributor, OEM Cap
Black, Red

JM6524

Buick SB V8 Engine, 65K Volt Coil
HEI Distributor
Black, Blue, Clear, Red
- Will not fit Buick SB 300

JM6525

Buick BB V8 Engine, 65K Volt Coil
HEI Distributor
Black, Blue, Clear, Red

JM6526

Buick Even Fire V6 Engine, 65K Volt Coil
HEI Distributor
Black, Blue, Clear, Red

JM6527

Ford 170/200/250 I6 Engine, 65K Volt
Coil, 5/16 Hex Shaft HEI Distributor
Black, Blue, Clear, Red

JM6528

Ford 240/300 I6 Engine, 65K Volt Coil
HEI Distributor
Black, Blue, Red

JM6529

Buick Odd Fire, 65K Volt Coil
HEI Distributor
Black, Red

JM6530

Early Hemi Mopar 392 Engine,
65K Volt Coil HEI Distributor
Black, Orange, Red

JM6531

Early Hemi Mopar 331/354 Engine,
65K Volt Coil HEI Distributor
Black, Orange, Red

JM6535

Buick Nailhead 322-425 V8 Engine,
65K Volt Coil HEI Distributor
Black, Red

PRO BILLET DISTRIBUTORS

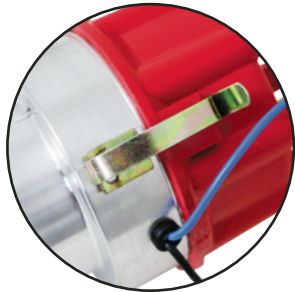

Quick clip-on 208 series cap

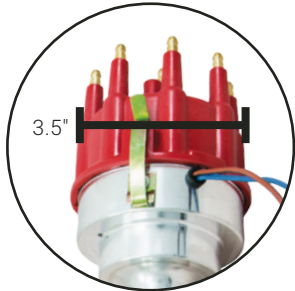

Compact 3.5" diameter design

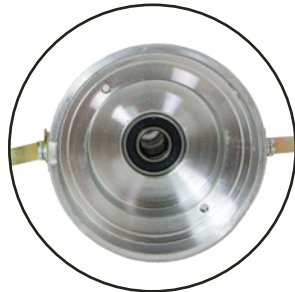

Ball bearing supported shaft



Hardened steel gears

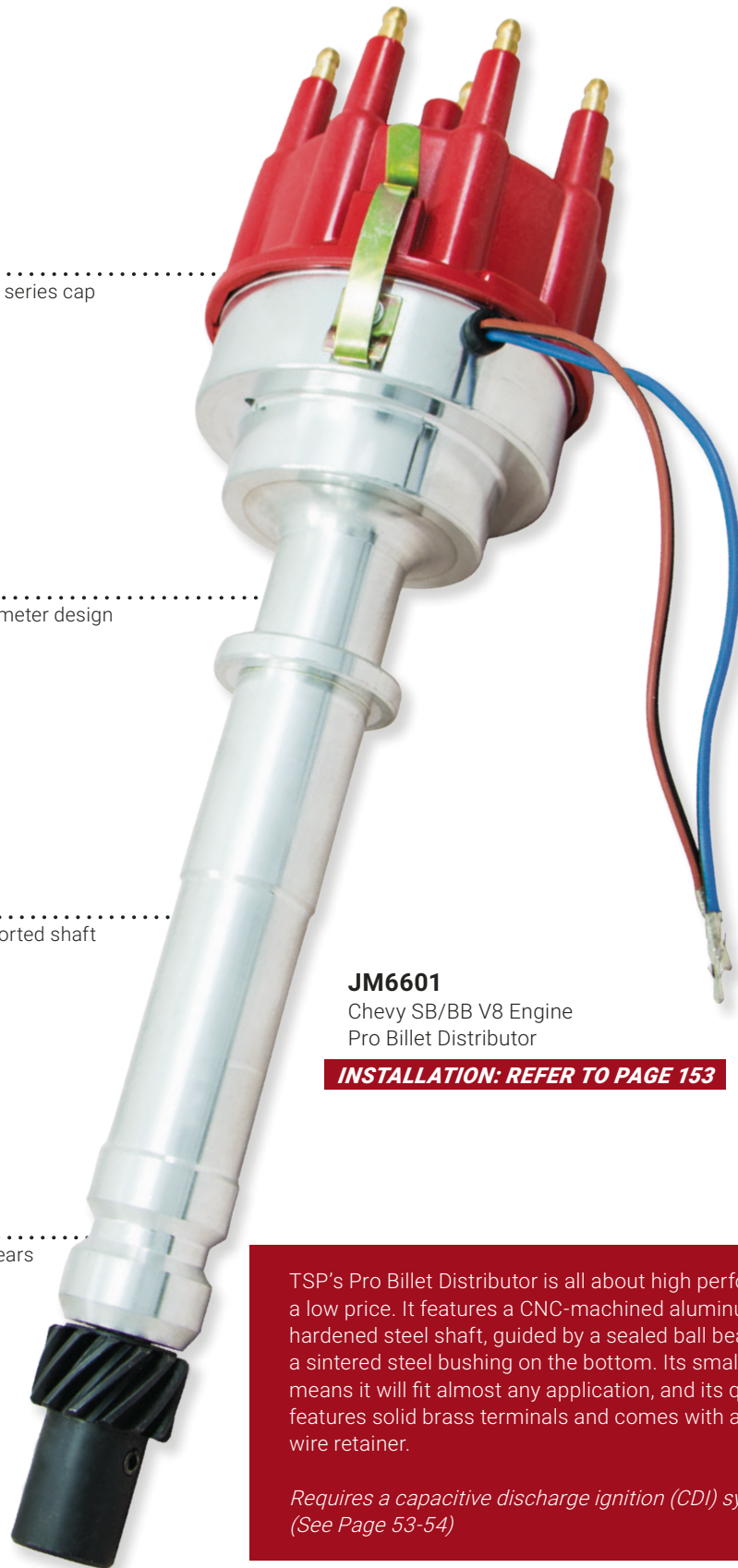

JM6601
Chevy SB/BB V8 Engine
Pro Billet Distributor

INSTALLATION: REFER TO PAGE 153

TSP's Pro Billet Distributor is all about high performance at a low price. It features a CNC-machined aluminum body and hardened steel shaft, guided by a sealed ball bearing on top and a sintered steel bushing on the bottom. Its small form factor means it will fit almost any application, and its quick clip-on cap features solid brass terminals and comes with a color-matched wire retainer.

*Requires a capacitive discharge ignition (CDI) system
(See Page 53-54)*

**JM6602****JM6606****JM6610****JM6613****JM6614**

PRO BILLET DISTRIBUTORS

JM6601*

Chevy SB/BB V8 Engine
Pro Billet Distributor
Black, Red

JM6602

Ford SB 289/302 V8 Engine
Pro Billet Distributor
Black, Blue, Red

JM6606

Ford 351 Cleveland/Ford BB 429-460
V8 Engine Pro Billet Distributor
Black, Blue, Red

JM6610

Ford 351 Windsor V8 Engine
Pro Billet Distributor
Black, Blue, Red

JM6613

Mopar SB 273/318/340/360
V8 Engine Pro Billet Distributor
Black, Blue, Red

JM6614

Mopar BB 413/426/440 V8 Engine
Pro Billet Distributor
Black, Blue, Red

*Will not work if it uses a governor

READY TO RUN DISTRIBUTORS



Quick clip-on 208 series cap

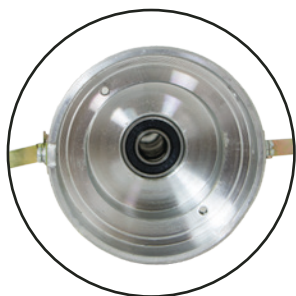

Ball bearing supported shaft



Easy change module



Compact 3.5" diameter design

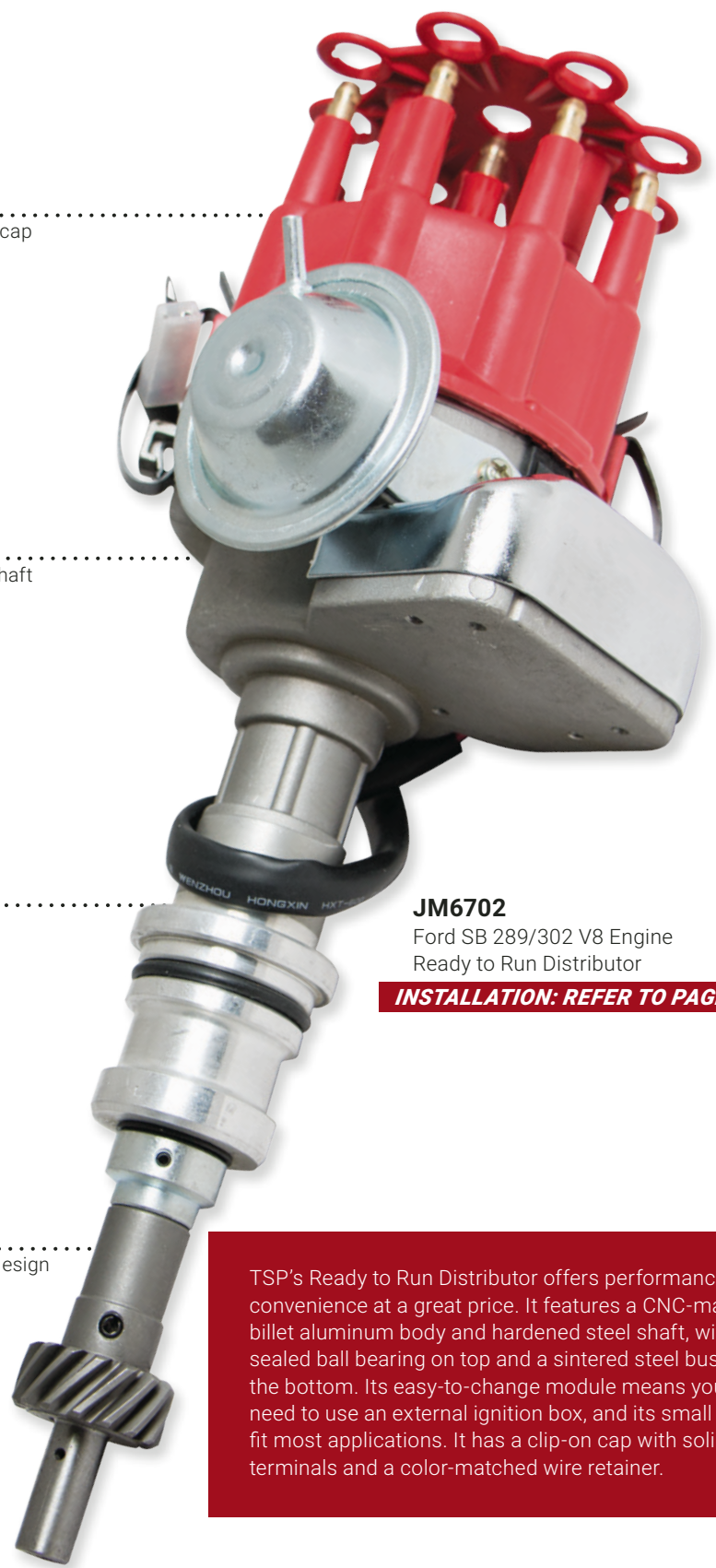

JM6702
Ford SB 289/302 V8 Engine
Ready to Run Distributor

INSTALLATION: REFER TO PAGE 154

TSP's Ready to Run Distributor offers performance and convenience at a great price. It features a CNC-machined billet aluminum body and hardened steel shaft, with a sealed ball bearing on top and a sintered steel bushing on the bottom. Its easy-to-change module means you won't need to use an external ignition box, and its small size will fit most applications. It has a clip-on cap with solid brass terminals and a color-matched wire retainer.



JM6701*



JM6704



JM6706



JM6710



JM6713



JM6714



JM6737



READY TO RUN DISTRIBUTORS

JM6701*

Chevy SB/BB V8 Engine
Ready to Run Distributor
Black, Blue, Red

JM6702

Ford SB 289/302 V8 Engine
Ready to Run Distributor
Black, Blue, Red

JM6704

Pontiac SB/BB V8 Engine
Ready to Run Distributor
Black, Blue, Red

JM6706

Ford 351 Cleveland/Ford BB 429-460
V8 Engine Ready to Run Distributor
Black, Blue, Red

JM6710

Ford 351 Windsor V8 Engine
Ready to Run Distributor
Black, Blue, Red

JM6713

Mopar SB 273/318/340/360 V8 Engine
Ready to Run Distributor
Black, Blue, Red

JM6714

Mopar BB 413/426/440 V8 Engine
Ready to Run Distributor
Black, Blue, Red

JM6737

Holden 253/304/308
Ready to Run Distributor
Black, Red

*Will not work if it uses a governor

EFI DISTRIBUTORS



Solid brass terminals



Includes zinc coated steel hold down

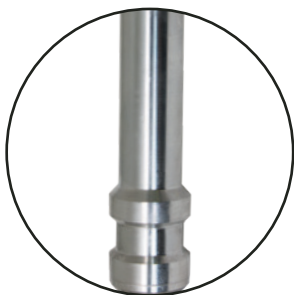

Increased strength over stock plastic units with full aluminum construction



JM6672
GM 5.0L/5.7L 1996-2002
V8 Engine Vortec Distributor

TSP's EFI Distributors offer a great alternative to the OEM price. They are designed and constructed to meet or exceed all OEM standards. With cast aluminum bodies and solid brass terminals, these are a no-brainer when replacing an EFI distributor.



JM6651



JM6652



JM6680



JM6684



JM6688



JM6691



JM6505

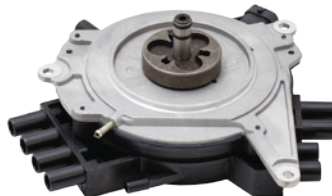

JM6507



JM6671



JM6673



EFI DISTRIBUTORS

Our EFI distributors are built from high quality materials in order to exceed OEM standards.

JM6651

GM EFI V6 Engine 1985-1996
EFI Distributor
Red

JM6652

GM EFI V8 Engine 1987-1994
EFI Distributor
Black, Red

JM6680

Ford 5.0L/302 V8 Engine 1985-1991
EFI Distributor
Black, Blue, Red

JM6684

Ford 5.8L/351 V8 Engine 1988-1991
EFI Distributor
Black, Blue, Red

JM6688

Ford 5.0L/302 V8 Engine 1991-1995
EFI Distributor
Black, Blue, Red

JM6691

Ford 5.8L/351 V8 Engine 1990-1995
EFI Distributor
Black, Blue, Red

OPTISPARK DISTRIBUTOR

JM6505

GM LT1 1992-1994 V8 Engine
Gen 1 Optispark Distributor
Black

JM6507

GM LT1 1995-1997 V8 Engine
Gen 2 Optispark Distributor
Black

VORTEC DISTRIBUTOR

JM6671

GM 4.3L 1996-2007
V6 Engine Vortec Distributor
Black

JM6672

GM 5.0L/5.7L 1996-2002
V8 Engine Vortec Distributor
Black

JM6673

GM 7.4L 1996-2000
V8 Engine Vortec Distributor
Black

IGNITION ACCESSORIES

Top Street Performance's 6AL Power Boxes

use the newest digital circuitry in the industry to provide maximum spark energy with less amp draw. The highly efficient electronics are housed inside a small form factor aluminum case for easy mounting on a firewall or fender of any vehicle.

- Improves spark at start and idle
- Full output at high RPM
- Adjustable Rev limiter
- Easy connection amplifiers, points, and magnetic pickup

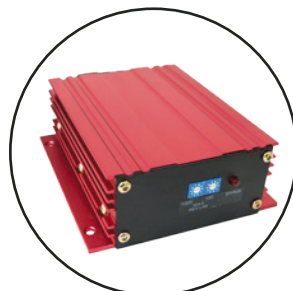

Digital Circuitry

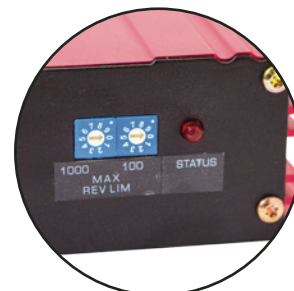

Adjustable Rev Limiter



JM6939

Mini Digital Power Box

- Spark: 95 MJ
- Primary Voltage: 435V
- Secondary: 45,000 Volts
- Spark Duration: 20° Crankshaft Rotation
- Current Draw: 0.7 AMPS per 1,000 RPM



JM6931

Digital Power Box

- Spark: 135-145 MJ
- Primary Voltage: 520-540V
- Secondary: 45,000 Volts
- Spark Duration: 20° Crankshaft Rotation
- Current Draw: 0.7 AMPS per 1,000 RPM



JM6929



JM6910



*Mounting Bracket Included

JM6927



JM6924



*Mounting Bracket Included

JM6928

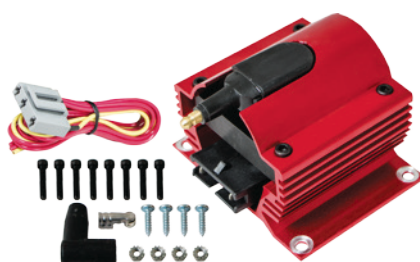

JM6930



JM6936



JM6937



JM6938



IGNITION ACCESSORIES

IGNITION BOXES

With increased spark intensity, the 6AL Power Box will help any engine produce more power, and increase throttle response. They're compatible with points and electronic ignitions. They work with 4, 6, and 8-cylinder engines. It will work best with TSP Pro Series Pro Billet Distributors.

JM6929

6AL Style Ignition Box
Black, Red

JM6931

Digital 6AL Power Box with Rev Limiter
Black, Red

JM6939

Mini Digital 6AL Power Box with Rev Limiter
Black, Red

IGNITION COILS

JM6910

HEI Ignition Coil, 65K Volt

JM6924

Compact External E-Core Ignition Coil,
40K Volt
Black, Red

JM6927

Canister Round Oil Filled Ignition Coil,
45K Volt, Female Socket,
Mounting Bracket Included
Black, Blue, Chrome, Red

JM6928

Canister Round Oil Filled Ignition Coil,
45K Volt, Male Socket,
Mounting Bracket Included
Black, Blue, Chrome, Red

JM6930

External E-Core Ignition Coil, 50K Volt
Black, Blue, Red

JM6936

GM 1985-1996 EFI Dual Connector
Ignition Coil, 48K Volt
Red

JM6937

GM 1986-2003 DIS Ignition Coil, 48K Volt
Red

JM6938

Ford 1984-1998 TFI Ignition Coil, 48K Volt
Blue, Red

TSP IGNITION COILS

- Magnetic steel cores specially designed to deliver 15% more spark than stock
- Shock and vibration resistant epoxy able to tolerate high temperatures
- Optimized winding
- Direct OEM replacement

JM6802-6

Ford/Mazda/Mercury 2000-2008
V6 Engine Ignition Coil, 35K Volt, 6pc/Set
Blue

JM6804-6

Ford/Mazda/Mercury 2000-2008
V6 Engine Ignition Coil, 35K Volt, 6pc/Set
Blue

JM6807

Ford/Mazda/Mercury 1998-2011
V6 Engine Ignition Coil, 40K Volt,
EDIS Horizontal Harness Connector
Blue

JM6808

Ford/Mazda/Mercury 1989-2000
V6 Engine Ignition Coil, 40K Volt,
EDIS Vertical Harness Connector
Blue

JM6809-8

Ford Coyote 5.0L 2011-2016 V8 Engine
Ignition Coil, 45K Volt, 8pc/Set
Blue

JM6810-6

Ford 2007-2016 V6 Engine
Ignition Coil, 45K Volt, 6pc/Set
Blue

JM6831

GM 1996-2001 Vortec Engine Ignition
Coil, 45K Volt, Single Connector HEI
Remote Mount Coil
Red

JM6945-8

Ford 1997-2014 SOHC 4.6L/5.4L/6.8L
V8 Engine, 2 Valve Ignition Coil
8 pc/Set - Blue

- *Will not fit 2004 and newer F150 with
5.4L V8 Engine. Use JM6946 for these
models.*

JM6946-8

Ford 2004-2008 SOHC 4.6L/5.4L/6.8L V8
Engine, 3 Valve Ignition Coil
8pc/Set - Blue



JM6802-6



JM6804-6



JM6807



JM6808



JM6809-8



JM6810-6



JM6831



JM6945-8



JM6946-8





JM6505CB



JM6507CB

IGNITION ACCESSORIES

JM6505CB
Chevy 1992-1994 Optispark
Wire Harness Cable

JM6507CB
Chevy 1995-1997 Optispark
Wire Harness Cable



JM6500CB



JM6930PT

JM6500CB
HEI Distributor Power & Tachometer
Pigtail Harness, 2-Piece

JM6930PT
Ignition Coil Wire Harness for JM6930

JM6933
HEI Distributor Power & Tachometer
Pigtail Harness, 1-Piece

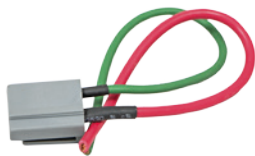

JM6933



JM6934

JM6934
HEI Distributor Module Bypass Harness
for 6AL Ignition Box

JM6902
HEI Distributor Replacement Wiring
Harness with Capacitor

JM6903
HEI Distributor OEM Coil Cover,
6 Cylinder
Black, Clear, Red



JM6902



JM6904

JM6904
HEI Distributor Cap Only, 8 Cylinder
Black, Blue, Clear, Red

JM6905
HEI Distributor OEM Cap Hardware Kit

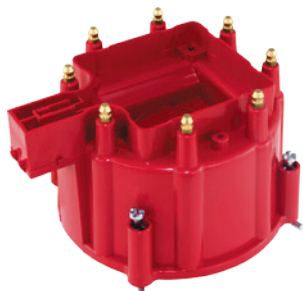

JM6905



JM6905

JM6906

HEI Distributor Super Coil Cover,
6 Cylinder/8 Cylinder
Black, Clear, Gray, Red



JM6906



JM6907



JM6907

HEI Distributor OEM Coil Cover,
8 Cylinder
Black, Blue, Red

JM6908

HEI Distributor OEM Cap Wire Retainer
Black, Blue, Red



JM6908



JM6912

JM6912

77XX Series Distributor Fully Adjustable
Vacuum Advance

JM6915

HEI Distributor Fully Adjustable
Vacuum Advance



JM6915



JM6913

JM6913

HEI Vacuum Advance Reverse
Rotation Lockout
Steel

JM6914

HEI Vacuum Advance Lockout, Steel

JM6916

HEI Distributor Rotor
Black, Blue, Clear, Red

JM6918

Pro Series Ready to Run Distributor
Circuit Board Module, Clockwise

JM6920

Pro Series Ready to Run Distributor
Circuit Board Module, Counterclockwise



JM6914



JM6916



JM6918



JM6920



JM6940



JM6919

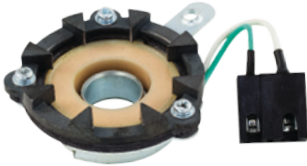

JM6925



JM6926



JM6917



JM6932



JM6941



JM6942



JM6943



JM6944

JM6940

HEI Distributor Circuit Board Module

JM6919

Pro Series Distributor Magnetic Pick-Up

JM6925

HEI Distributor V8 Engine Pick-Up Coil

JM6926

Chevy HEI Distributor Hold Down Clamp
V6 & V8 Engine
Black, Blue, Red, Silver

**DISTRIBUTOR IGNITION
MODULE**

JM6917

4-Pin HEI Distributor Ignition Module
For 65XX Series

JM6932

Ready to Run Distributor Ignition Module
For 67XX Series

JM6941

Optispark Distributor Ignition Module/
Optical Sensor (JM6505), 1992-1994

JM6942

Optispark Distributor Ignition Module/
Optical Sensor (JM6507), 1995-1997

JM6943

GM EFI Distributor Ignition Module

JM6944

GM Vortec Distributor Ignition Module

DISTRIBUTOR CAP KITS

JM6949

HEI Distributor Cap Kit, 6 Cylinder
Odd-Fire
Includes: OEM Cap, Coil Cover, Rotor
Black, Red

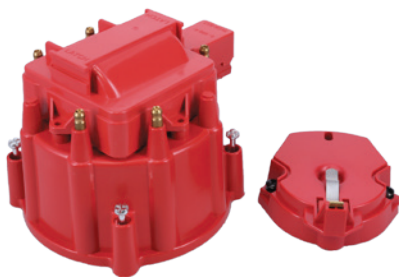

JM6949



JM6950



JM6950

HEI Distributor Cap Kit, 8 Cylinder
Includes: Super Cap, Coil Cover, Rotor
Black, Blue, Clear, Gray, Red

JM6951

HEI Distributor Cap Kit, 8 Cylinder
Includes: OEM Cap, Coil Cover, Rotor
Black, Blue, Clear, Orange, Red

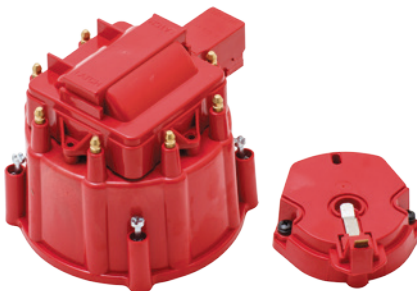

JM6951



JM6952



JM6952

HEI Distributor Cap Kit, 6 Cylinder
Includes: Super Cap, Coil Cover, Rotor
Black, Clear, Red

JM6953

HEI Distributor Cap Kit, 6 Cylinder
Includes: OEM Cap, Coil Cover, Rotor
Black, Blue, Clear, Red



JM6953



JM6971



JM6971

Pro Billet/Ready to Run Distributor Cap
Kit, 8 Cylinder
Includes: Male Cap & Rotor
Black, Blue, Red

JM6972

Pro Billet/Ready to Run Distributor Cap
Kit, 8 Cylinder
Includes: Female Cap & Rotor
Black, Blue, Red



JM6972



JM6973



JM6973

Pro Series Pro Billet/Pro Series Ready to
Run Distributor Cap Kit, 8 Cylinder
Includes: Male Cap, Wire Retainer, Rotor
Black, Blue, Red

JM6974

Pro Series Pro Billet/Pro Series Ready to
Run Distributor Cap Kit, 8 Cylinder
Includes: Female Cap & Rotor
Black, Blue, Red

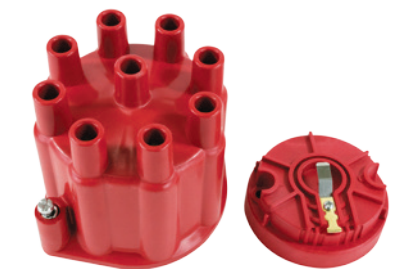

JM6974



JM6975



JM6975

Pro Series Pro Billet/Pro Series
Ready to Run Distributor Cap Kit,
6 Cylinder
Includes: Male Cap, Wire Retainer, Rotor
Black, Blue, Red



JM6976



JM6977



JM6981



JM6982

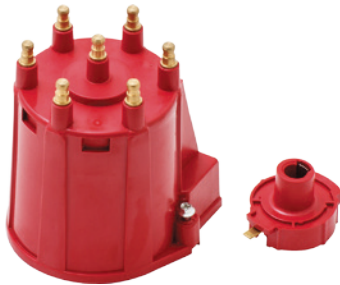

JM6983

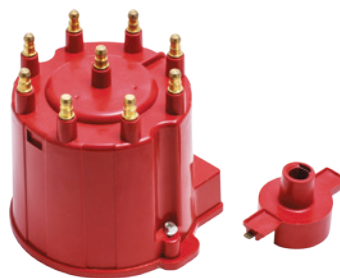

JM6984



JM6985



JM6986



JM6991



JM6992



JM6976

Pro Series Pro Billet/Pro Series Ready to Run Distributor Cap Kit, 6 Cylinder
Includes: Female Cap & Rotor
Black, Blue, Red

JM6977

Ford EFI Distributor Cap Kit, 8 Cylinder
Includes: OEM Cap & Rotor
Black, Blue, Red

JM6981

GM LT1 Optispark Distributor Cap Kit, 1992-1994
Includes: Cap & Rotor
Black

JM6982

GM LT1 Optispark Distributor Cap Kit, 1995-1997
Includes: Cap & Rotor
Black

JM6983

GM EFI Distributor Cap Kit 6 Cylinder
Includes: Cap & Rotor
Red

JM6984

GM EFI Distributor Cap Kit 8 Cylinder
Includes: Cap & Rotor
Black, Red

JM6985

GM Vortec Distributor Cap Kit 6 Cylinder
Includes: Cap & Rotor
Black

JM6986

GM Vortec Distributor Cap Kit 8 Cylinder
Includes: Cap & Rotor
Black

JM6991

Complete HEI Distributor Tune Up Kit 8 Cylinder
Includes: Super Cap, Coil, Module, Rotor
Black, Clear, Gray, Red

JM6992

Complete HEI Distributor Tune Up Kit 8 Cylinder
Includes: OEM Cap, Coil, Module, Rotor
Black, Blue, Clear, Orange, Red

DISTRIBUTOR GEARS

JM6954BZ

Chevy SB/BB Distributor Gear
V6/V8 Engine, 0.491" Shaft
Bronze



JM6954BZ



JM6955S

JM6955S

Chevy SB/BB Distributor Gear
V6/V8 Engine, 0.491" Shaft
Steel

JM6956S

Ford SB Distributor Gear
V8 Engine, 0.491" Shaft
Steel



JM6956S



JM6957S

JM6957S

Oldsmobile SB/BB Distributor Gear
V8 Engine, 0.491" Shaft
Steel

JM6958S

Pontiac SB/BB Distributor Gear
V8 Engine, 0.491" Shaft
Steel



JM6958S



JM6959S

JM6959S

Ford BB/351 Cleveland Distributor Gear
V8 Engine, 0.491" Shaft
Steel

JM6960S

Ford FE Distributor Gear
V8 Engine, 0.491" Shaft
Steel



JM6960S



JM6961S

JM6961S

Jeep Distributor Gear
I6 Engine, 0.491" Shaft
Steel

JM6962S

Jeep Distributor Gear
V8 Engine, 0.491" Shaft
Steel



JM6962S



JM6963S

JM6963S

Chevy Distributor Gear
I6 Engine, 0.491" Shaft
Steel



JM6964S



JM6965S



JM6966BZ



JM6967S



JM6968S



JM6969S



JM6970S



JM6979

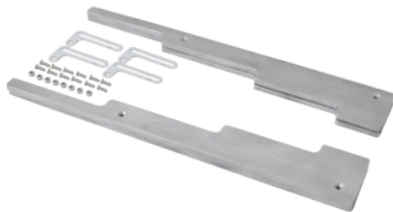

JM9001

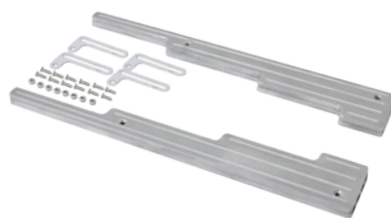

JM9002



JM6964S

Buick SB Distributor Gear
V8 Engine, 0.491" Shaft
Steel

JM6965S

Buick BB Distributor Gear
V8 Engine, 0.491" Shaft
Steel

JM6966BZ

Chevy SB/BB Distributor Gear
V6/V8 Engine, 0.500" Shaft
Bronze

JM6967S

Chevy SB/BB Distributor Gear
V6/V8 Engine, 0.500" Shaft
Steel

JM6968S

Ford SB Distributor Gear
V8 Engine, 0.500" Shaft
Steel

JM6969S

Ford BB/351 Cleveland Distributor Gear
V8 Engine, 0.500" Shaft
Steel

JM6970S

Chevy Corvair Distributor Gear
Flat 6 Engine, 0.491" Shaft
Steel

JM6979

Mopar Distributor Gear
Slant-6 Engine, 0.500" Shaft
Plastic

WIRE LOOM SET

JM9001

Billet Aluminum Wire Loom Set,
9.5mm Smooth
Chrome, Polished

JM9002

Billet Aluminum Wire Loom Set,
9.5mm Ball-Milled
Chrome, Polished



8.5MM IGNITION WIRE SETS

TSP's premium ignition wires are designed for superior performance and durability. A high-quality silicone outer jacket guarantees protection from moisture and chemicals. Rated at 550° F, they hold up well to extreme heat. The spiral wound core suppresses RFI and features 500 ohm per foot resistance for excellent performance. Universal sets are available in multiple colors and boot angles, and pre-cut sets are available for several LS applications.

- Spiral-wound core suppresses radio frequency interference (RFI) and provides greater strength and durability
- 500 ohm-per-foot resistance increases energy to the spark plug, delivering better performance and fuel efficiency
- High quality silicone jacket is rated at 550° F and has a gloss finish to resist wear from chemicals and moisture
- Optional ceramic boots provide unbeatable heat protection, putting an end to burnt spark plug boots

UNIVERSAL FIT TSP IGNITION WIRE SETS

PRODUCT NO.	DESCRIPTION	CYLINDER	WIRE COLOR
85035	8.5MM UNIVERSAL IGNITION WIRES WITH 135° ANGLE PLUG BOOTS	8	BLACK
85235	8.5MM UNIVERSAL IGNITION WIRES WITH 135° ANGLE PLUG BOOTS	8	RED
85635	8.5MM UNIVERSAL IGNITION WIRES WITH 135° ANGLE PLUG BOOTS	8	BLUE
85090	8.5MM UNIVERSAL IGNITION WIRES WITH 90° ANGLE PLUG BOOTS	8	BLACK
85290	8.5MM UNIVERSAL IGNITION WIRES WITH 90° ANGLE PLUG BOOTS	8	RED
85690	8.5MM UNIVERSAL IGNITION WIRES WITH 90° ANGLE PLUG BOOTS	8	BLUE
85080	8.5MM UNIVERSAL IGNITION WIRES WITH 180° STRAIGHT PLUG BOOTS	8	BLACK
85280	8.5MM UNIVERSAL IGNITION WIRES WITH 180° STRAIGHT PLUG BOOTS	8	RED
85680	8.5MM UNIVERSAL IGNITION WIRES WITH 180° STRAIGHT PLUG BOOTS	8	BLUE
81025	8.5MM UNIVERSAL LS/LT IGNITION WIRES WITH 180° STRAIGHT PLUG BOOTS	8	BLACK
81225	8.5MM UNIVERSAL LS/LT IGNITION WIRES WITH 180° STRAIGHT PLUG BOOTS	8	RED

LS TSP IGNITION WIRE SETS

PRODUCT NO.	DESCRIPTION	CYLINDER	WIRE COLOR
81026	8.5MM LS 9-3/4" IGNITION WIRES WITH WITH 180° STRAIGHT PLUG BOOTS	8	BLACK
81027	8.5MM LS 12" IGNITION WIRES WITH WITH 180° STRAIGHT PLUG BOOTS	8	BLACK
81028	8.5MM LS 9-3/4" IGNITION WIRES WITH 135° ANGLE PLUG BOOTS	8	BLACK
81226	8.5MM LS 9-3/4" IGNITION WIRES WITH WITH 180° STRAIGHT PLUG BOOTS	8	RED
81227	8.5MM LS 12" IGNITION WIRES WITH WITH 180° STRAIGHT PLUG BOOTS	8	RED
81228	8.5MM LS 9-3/4" IGNITION WIRES WITH 135° ANGLE PLUG BOOTS	8	RED

PRE-MADE CHEVY HEI TSP IGNITION WIRE SETS

PRODUCT NO.	DESCRIPTION	CYLINDER	WIRE COLOR
82080	8.5MM CHEVY BB IGNITION WIRES WITH 180° STRAIGHT PLUG BOOTS	8	BLACK
82280	8.5MM CHEVY BB IGNITION WIRES WITH 180° STRAIGHT PLUG BOOTS	8	RED
82080CE	8.5MM CHEVY BB IGNITION WIRES WITH 180° STRAIGHT CERAMIC PLUG BOOTS	8	BLACK
82090	8.5MM CHEVY SB IGNITION WIRES WITH 90° ANGLE PLUG BOOTS	8	BLACK
82290	8.5MM CHEVY SB IGNITION WIRES WITH 90° ANGLE PLUG BOOTS	8	RED
82090CE	8.5MM CHEVY SB IGNITION WIRES WITH 90° ANGLE CERAMIC PLUG BOOTS	8	BLACK

CERAMIC TSP IGNITION WIRE SETS

PRODUCT NO.	DESCRIPTION	CYLINDER	WIRE COLOR
85090CE	8.5MM UNIVERSAL IGNITION WIRES WITH 90° ANGLE CERAMIC PLUG BOOTS	8	BLACK
85080CE	8.5MM UNIVERSAL IGNITION WIRES WITH 180° STRAIGHT CERAMIC PLUG BOOTS	8	BLACK
85035CE	8.5MM UNIVERSAL IGNITION WIRES WITH 135° ANGLE CERAMIC PLUG BOOTS	8	BLACK
81025CE	8.5MM UNIVERSAL LS/LT IGNITION WIRES WITH 180° STRAIGHT CERAMIC PLUG BOOTS	8	BLACK
81027CE	8.5MM LS 12" IGNITION WIRES WITH WITH 180° STRAIGHT CERAMIC PLUG BOOTS	8	BLACK
81028CE	8.5MM LS 9-3/4" IGNITION WIRES WITH 135° ANGLE CERAMIC PLUG BOOTS	8	BLACK

TSP SPARK PLUG BOOT PROTECTORS

PART NO.	DESCRIPTION	LENGTH	ID	WIRE COLOR
85020	SPARK PLUG BOOT PROTECTORS, SET OF 8	6.00"	1.00"	BLACK
85220	SPARK PLUG BOOT PROTECTORS, SET OF 8	6.00"	1.00"	RED
85620	SPARK PLUG BOOT PROTECTORS, SET OF 8	6.00"	1.00"	BLUE

Maximum Ambient Temperature (F): 1,200 degrees F



ALTERNATORS



Side Battery Post: Clearance from tight cylinder head spaces

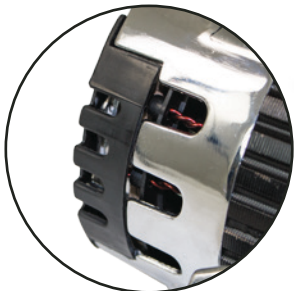

160 AMP



Ball bearing

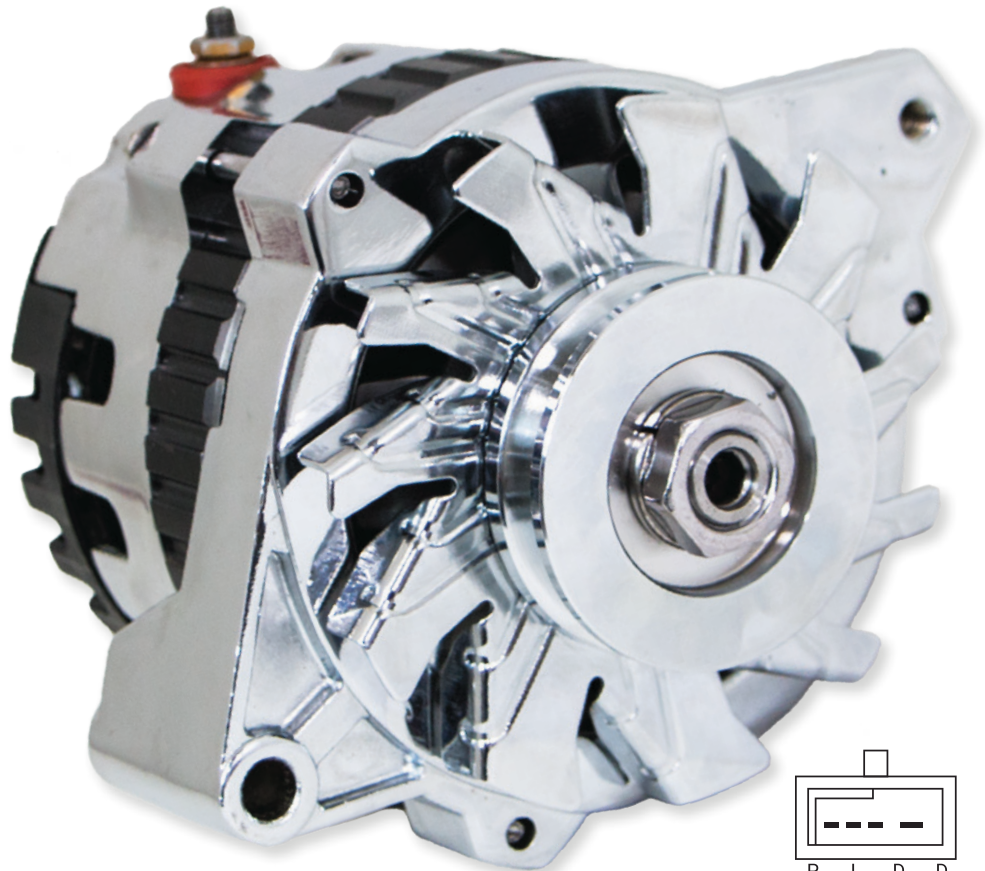

ES1005

GM CS130 Alternator with Side Battery Post, 160 AMP, V-Belt

MORE DIMENSIONS: REFER TO PAGES 158-160

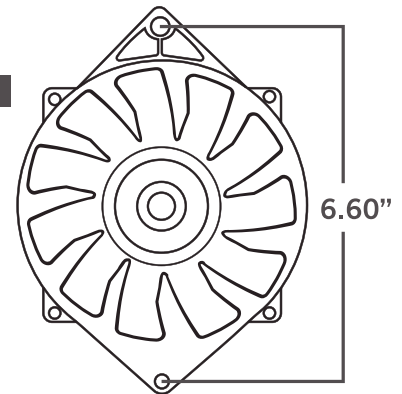
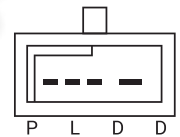

TSP's alternators are a fantastic upgrade to any engine, whether it's for looks or performance and reliability. They feature simple wiring and a huge amperage upgrade over stock. Available in multiple finishes, they are offered with v-belt or serpentine pulleys. Why choose function over fashion when you can have both?

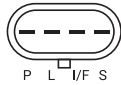
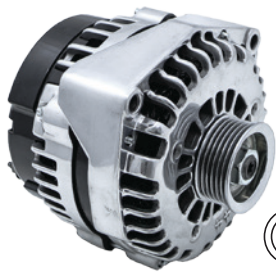
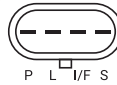
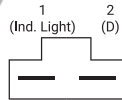
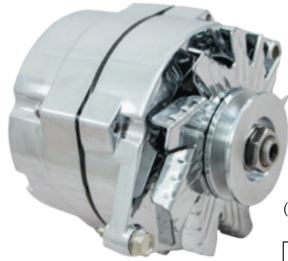
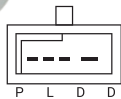
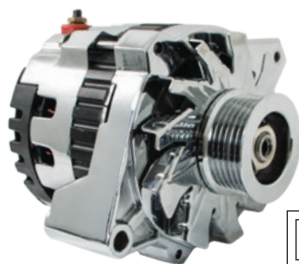
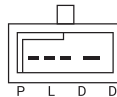
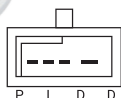
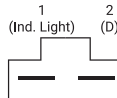
**ES1024****ES1025****ES1001****1-WIRE****ES1004****ES1006****1-WIRE****ES1014****1-WIRE****ES1015****ES1022****ES1026****ES1031**

ALTERNATORS

LS ALTERNATOR

ES1024

LS Truck AD244 Alternator, 220 AMP, Serpentine Belt, 4 Pin Connector
Black, Chrome

ES1025

LS Car CS130D Alternator, 180 AMP, Serpentine Belt, 4 Pin Connector
Black, Chrome

GM ALTERNATOR

ES1001

GM 10SI Alternator, 110 AMP, V-Belt, 1 or OEM Wire Setup, Fits 1968-1982
Black, Chrome

ES1004

GM Mini Denso Style Alternator, Street Rod Race, 90 AMP, 1/2 inch V-Belt, 1-Wire Setup
Black, Chrome, Satin

ES1005

GM CS130 Alternator with Side Battery Post, 160 AMP, V-Belt, 1 or OEM Wire Setup, Fits 1968-1995
Chrome

ES1006

GM CS130 Alternator with Side Battery Post, 160 AMP, Serpentine Belt, 1 or OEM Wire Setup, Fits 1968-1995
Black, Chrome

ES1014

GM Mini Denso Style Alternator, Street Rod Race, 90 AMP, 3/8 inch V-Belt, 1-Wire Setup
Black, Chrome, Satin

ES1015

GM Mini Denso Style Alternator, Street Rod Race, 90 AMP, Serpentine Belt, 1-Wire Setup
Black, Chrome, Satin

ES1022

GM CS130 Alternator, 220 AMP, V-Belt, 1 or OEM Wire Setup, Fits 1968-1995
Black, Chrome

ES1026

GM CS130 Alternator, 220 AMP, Serpentine Belt, 1 or OEM Wire Setup, Fits 1968-1995
Chrome

FORD ALTERNATOR

ES1031

Ford 1G Alternator, 110 AMP, V-Belt, 1 or OEM Wire Setup, Fits 1963-1986
Black, Chrome

VW ALTERNATOR**ES1050**

VW Beetle, Mini Bus Type II 1.6L,
Melrose Sprayers with 1.6L Engine
Alternator, 55 AMP
Chrome

**ES1050**

1-WIRE

ES1013**MOPAR ALTERNATOR****ES1013**

Mopar Internally Regulated Alternator,
100 AMP, 1-Wire Setup
Black, Chrome, Satin

**ALTERNATOR
REPLACEMENT PARTS****ES1005W**

GM CS130 to GM 10SI Adapter Cable

**ES1005W****ES1006W****ES1006W**

GM CS130D to GM CS130 Adapter Cable
for 81200 Serpentine Kit

ES1091

GM 10SI Alternator Dress Up Kit
Chrome

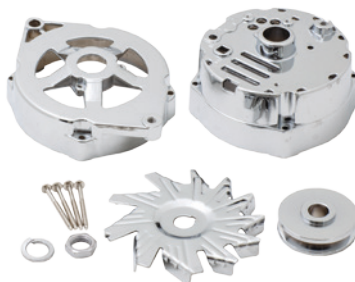
**ES1091****ES1093**

GM Mini Denso Style, Single Groove
3/8 inch V-Belt, Steel Alternator Pulley
Black

**ES1093****ES1094**

Single Groove V-Belt, Steel
Alternator Pulley
Chrome

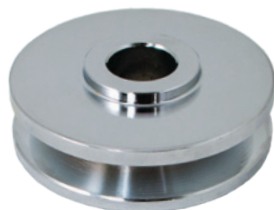
**ES1094****ES1095**

GM Mini Denso Style, 6-Groove
Serpentine Belt, Steel Alternator Pulley
Black

**ES1095****ES1096**

Steel Alternator Fan Blade
Chrome

**ES1096**



TSP[®]
TOP STREET PERFORMANCE

STARTERS



Staggered Bolt Pattern



Compatible to 168 Tooth Flywheel

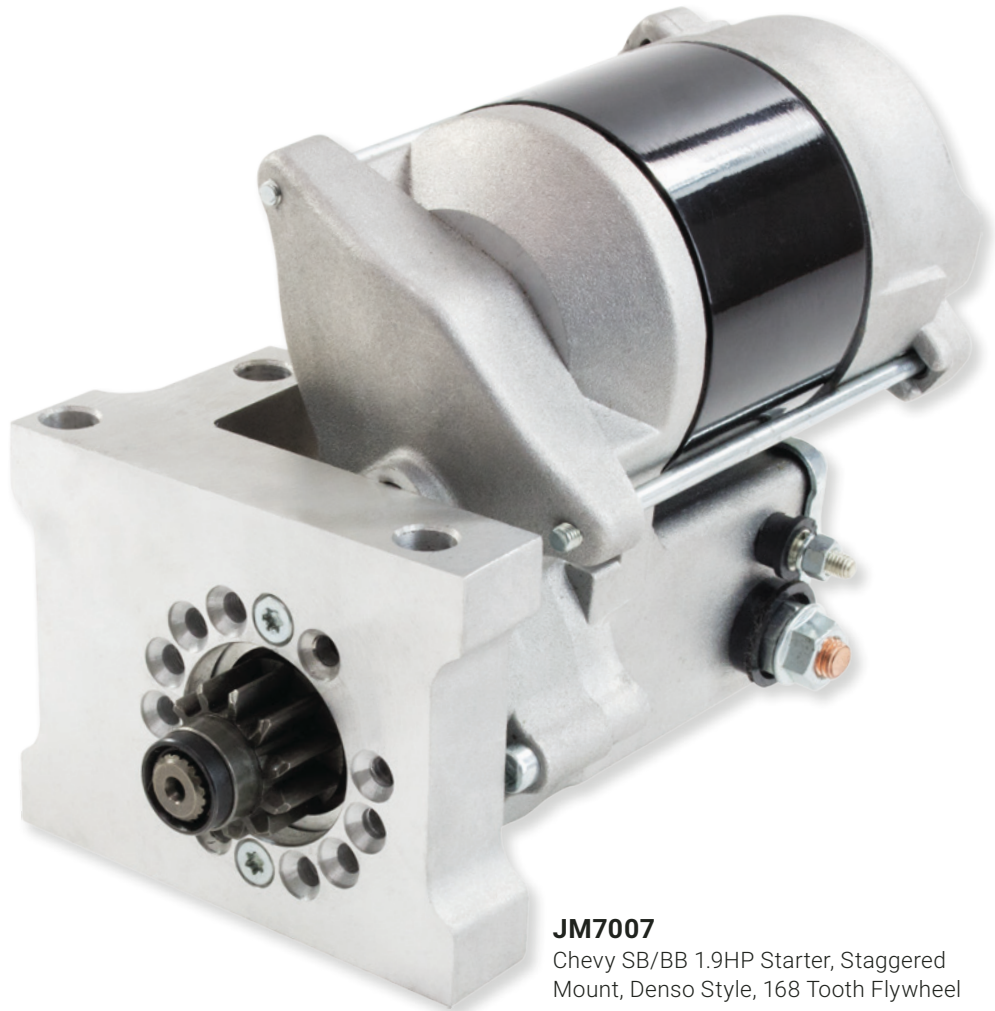

Natural Finish

**JM7007**

Chevy SB/BB 1.9HP Starter, Staggered Mount, Denso Style, 168 Tooth Flywheel

STARTER DIMENSIONS: REFER TO PAGE 161

TSP's starters guarantee reliable starting power. After all, what's the point of a high-performance engine if it doesn't start? Featuring a compact design for added clearance, they will fit most engine configurations. TSP offers starters in multiple styles and finishes.

**JM7001SK****JM7002****JM7003****JM7013****JM7001****JM7009****JM7008**

STARTERS

GM STARTER

The compact design of our reliable Chevy starter has been combined with a billet aluminum LS mounting plate which can be rotated to multiple positions for a wide range of OEM and LS swap applications.

JM7001SK

JM7001 Shim Bolt Kit

JM7001

Chevy SB/BB 3HP High Torque Starter, 153 or 168 Tooth Flywheel, Tilton Style
Black, Chrome, Red

JM7002

LS 3HP High Torque Starter
Tilton Style
Black, Chrome, Red

JM7007

Chevy SB/BB 1.9HP Starter, Staggered Mount, Denso Style, 168 Tooth Flywheel
All Black, Black, Red

JM7009

LS 1.9HP Starter, Denso Style
All Black, Black, Red

FORD STARTER

JM7003

Ford SB/BB/FE 3HP High Torque Starter, Tilton Style
Black, Chrome
*- Will not work on manual transmission
Ford SB/BB 1979 and older;
Ford FE 1963 and older*

OLDSMOBILE/PONTIAC STARTER

JM7008

Oldsmobile/Pontiac 1.9HP Starter, Denso Style
All Black, Black, Red
- Will not fit 301

MOPAR STARTER

JM7013

Mopar SB/BB/Hemi 1966-1987 1.9HP Starter with Nose, Denso Style
All Black, Red

WATER PUMPS



1/2" Hub, 25% thicker than OEM for more durability



Made from light weight 356-T Aluminum



Heavy duty bearings & seals



8 blade cast aluminum anti-cavitation impeller



HC8012
Chevy SB Aluminum Mechanical Water Pump, Long Style

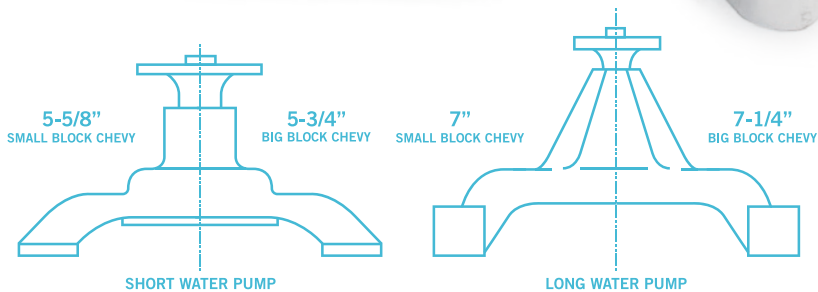

TSP's High Flow Water Pumps offer that extra cooling power you need for your street performance engine. With an 8-blade, cast aluminum anti-cavitation impeller, these flow at about 40% above most stock pumps. The heavy duty bearings and seals keep the shaft stable, ensuring excellent performance and reliability. The housings are cast from lightweight A356-T6 aluminum and come in multiple finishes to achieve any desired aesthetic.



HC8004



HC8008



HC8009



HC8011



HC8013



HC8014



HC8021



HC8022



HC8023



HIGH FLOW MECHANICAL WATER PUMPS

PONTIAC WATER PUMP

HC8004

Pontiac SB/BB Aluminum Mechanical Water Pump
Chrome, Polished, Satin

CHEVY WATER PUMP

HC8008

1971-1982 Chevy SB Corvette/Chevy SB Circle Track Aluminum Mechanical Water Pump with 3/4" Shaft, Short Style
Chrome, Polished, Satin

HC8009

Chevy 348/409 Aluminum Mechanical Water Pump
Chrome, Polished, Satin

HC8011

Chevy SB Aluminum Mechanical Water Pump, Short Style
Black, Chrome, Polished, Satin

HC8012

Chevy SB Aluminum Mechanical Water Pump, Long Style
Black, Chrome, Polished, Satin

HC8013

Chevy SB Reverse Rotation Aluminum Mechanical Water Pump, Short Style
Chrome, Polished, Satin

HC8014

Chevy SB Reverse Rotation Aluminum Mechanical Water Pump, Long Style
Black, Chrome, Polished, Satin

HC8021

Chevy BB Aluminum Mechanical Water Pump, Short Style
Black, Chrome, Polished, Satin

HC8022

Chevy BB Aluminum Mechanical Water Pump, Long Style
Black, Chrome, Polished, Satin

HC8023

Chevy BB Reverse Rotation Aluminum Mechanical Water Pump, Short Style
Black, Chrome, Polished, Satin

FORD WATER PUMP

HC8049 (Passenger Side Inlet)

Ford SB 289/302/351 Windsor
Aluminum Mechanical Water Pump,
Passenger Side Inlet
Black, Chrome, Polished, Satin



HC8049



HC8050



HC8050 (Driver Side Inlet)

Ford SB 289/302/351 Windsor
Aluminum Mechanical Water Pump,
Driver Side Inlet
Chrome, Polished, Satin

HC8051

Ford 351 Cleveland/351M/400
Aluminum Mechanical Water Pump
Chrome, Polished, Satin



HC8051



HC8052



HC8052

Ford BB 429/460 Aluminum
Mechanical Water Pump
Chrome, Polished, Satin
- Will not fit 1969 Ford 429 Boss

HC8053

Ford FE 352**/390/406/410/427/428
Aluminum Mechanical Water Pump
Chrome, Polished, Satin
***Will not fit 1958-1960*



HC8053



HC8054*



HC8054*

Ford SB 302/351 Windsor Reverse
Rotation Aluminum Mechanical
Water Pump
Fits 1985-1993
Chrome, Polished, Satin

LS WATER PUMP

HC8935*

LS Truck 4.8L/5.3L/6.0L,
Aluminum Mechanical Water Pump
Fits 1999-2006, OEM Replacement
Satin



HC8935*



HC8936



HC8936

TSP LS Customized Aluminum
Mechanical Water Pump with Hub for
81200 Serpentine Front End Kit
Black, Chrome

LT WATER PUMP

HC8933

LT1/LT4 Aluminum Mechanical Water
Pump Fits 1992-1997
Satin



HC8933



*OEM Replacement



HC8010



HC8020



HC8030



HC8031



HC8040



HIGH FLOW ELECTRIC WATER PUMPS

Designed to flow at a constant 35 gpm, regardless of engine speed, TSP's electric water pumps provide superior cooling without the horsepower draw of a mechanical pump.

CHEVY WATER PUMP

HC8010

Chevy SB 35 GPM Aluminum Electric Water Pump

Black, Chrome

- Will not fit with an 8" harmonic balancer

HC8020

Chevy BB 35 GPM Aluminum Electric Water Pump

Black, Chrome

FORD WATER PUMP

HC8030

Ford SB 289/302/351 Windsor 35 GPM Aluminum Electric Water Pump,

Back Plate Included

Black, Chrome

HC8031

Ford 351 Cleveland 35 GPM Aluminum Electric Water Pump, Back Plate Included

Black, Chrome

HC8040

Ford BB 429/460 35 GPM Aluminum

Electric Water Pump, Back Plate Included

Black, Chrome

WATER NECKS

Finish your engine dress-up with a high-quality, aluminum water neck, available in multiple finishes.

SP8455

Chevy SB/BB 45° Aluminum Water Neck
360° Swivel, 283-454 V8 Engine
Black, Polished



SP8455



SP8456



SP8456

Chevy SB/BB 90° Aluminum Water Neck
360° Swivel, 283-454 V8 Engine
Black, Polished



SP8459



HC8940

HC8940

LS 160° Thermostat

HC8937

LS 45° Aluminum Water Neck
360° Swivel
Black, Chrome



HC8937



HC8937-KT



HC8938

LS Straight Aluminum Water Neck
Black, Chrome

HC8938-KT

LS Straight Aluminum Water Neck
with 160° Thermostat
Black, Chrome



HC8938



HC8938-KT



HC8939

LS -12AN Fitting Water Neck and
Water Pump Adapter

HC8939-KT

LS -12AN Fitting Water Neck and
Water Pump Adapter with
160° Thermostat



HC8939



HC8939-KT



HC5001



HC5002



HC5003



HC5004



HC5005



HC50100



HC5101



A/C COMPRESSORS

TSP's A/C compressors are housed in lightweight aluminum and include PAG 100 oil for easy installation. Available in multiple styles and finishes, they are a great way to upgrade your A/C and improve the look of your engine.

HC5001

Sanden 508 R134A Style
A/C Compressor V-Belt, Black Clutch
Black, Chrome

HC5002

Sanden 508 R134A Style
A/C Compressor Serpentine Belt,
Black Clutch
Black, Chrome

HC5003

Sanden 508 R134A Style
A/C Compressor V-Belt, Silver Clutch
Chrome

HC5004

Sanden 508 R134A Style
A/C Compressor Serpentine Belt,
Silver Clutch
Chrome

HC5005

Sanden SD-7 Style A/C Compressor
Serpentine Belt, 6 Groove, Silver Clutch
Black, Chrome

HC5100

Sanden SD-7 Style A/C Compressor
Manifold, Vertical
Black, Polished

HC5101

Sanden SD-7 Style A/C Compressor
Manifold, Curved
Black, Polished

OVERFLOW TANKS

Top Street Performance polished stainless steel overflow tanks add style to an engine compartment with a sleek design. They feature a twist on aluminum cap, 5/16" pipe size, and includes complete hardware and brackets to fit your application.



HC6321
2" x 10" Overflow Tank, Stainless Steel
Fluid Capacity: 14 oz.



HC6322
2" x 13" Overflow Tank, Stainless Steel
Fluid Capacity: 18 oz.



HC6323
2" x 15" Overflow Tank, Stainless Steel
Fluid Capacity: 22 oz.



HC6324
2" x 17" Overflow Tank, Stainless Steel
Fluid Capacity: 26 oz.



HC6325
2" x 19" Overflow Tank, Stainless Steel
Fluid Capacity: 30 oz.



HC6326
3" x 9" Overflow Tank, Stainless Steel
Fluid Capacity: 24 oz.



HC6327
3" x 10" Overflow Tank, Stainless Steel
Fluid Capacity: 34 oz.



HC6328
3" x 16" Overflow Tank, Stainless Steel
Fluid Capacity: 52 oz.



**Mounting Brackets and
Hardware Included*



**Mounting Brackets and
Hardware Included*

UNIVERSAL TRANSMISSION OIL COOLERS

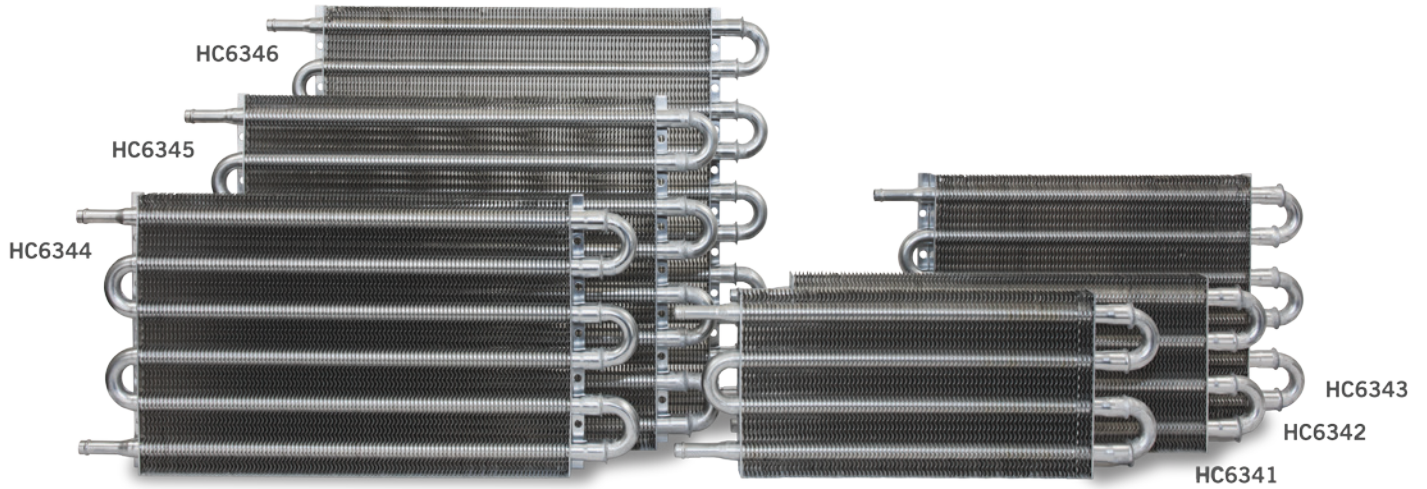

PRODUCT NO.	LENGTH	HEIGHT	WIDTH	INLET/OUTLET
HC6341	12 3/4"	5"	3/4"	3/8"
HC6342	15 1/2"	5"	3/4"	3/8"
HC6343	12 3/4"	7 1/2"	3/4"	3/8"
HC6344	15 1/2"	7 1/2"	3/4"	3/8"
HC6345	15 1/2"	10"	3/4"	3/8"
HC6346	15 1/2"	12 1/2"	3/4"	3/8"



*Accessories Included

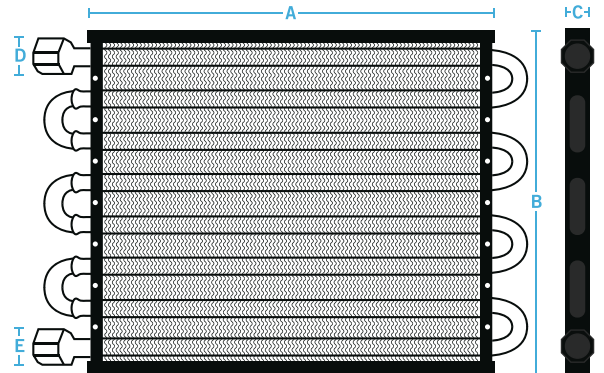
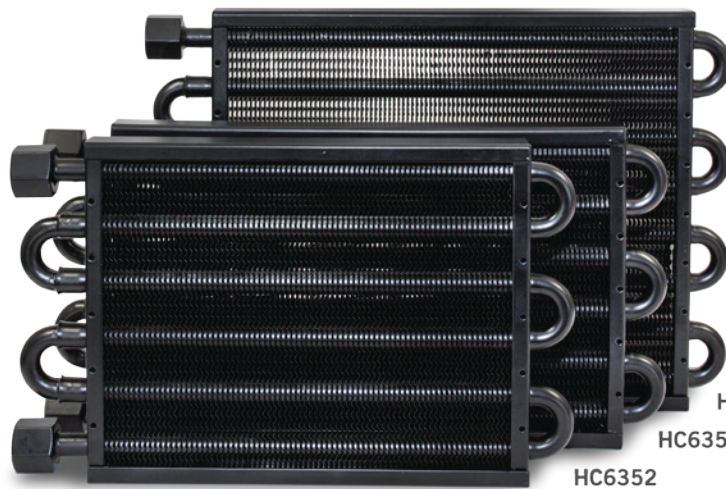

PRODUCT NO.	LENGTH	HEIGHT	WIDTH	INLET/OUTLET
HC6352	12 3/4"	7 1/2"	3/4"	M18 x 1.5" FITTING
HC6354	15 1/2"	7 1/2"	3/4"	M18 x 1.5" FITTING
HC6356	15 1/2"	10"	3/4"	M18 x 1.5" FITTING



RADIATORS, SHROUDS AND FANS



HC9511

Universal Chevy Single Fan Pro Flow Radiator Kit

Cut-outs with flaps for increased airflow

TSP's Radiators are constructed of lightweight aluminum and are 100% TIG welded, using absolutely no epoxy. They feature an extremely efficient cross-flow design with two rows of 1" tubes and 17 fins per inch. These design features ensure maximum cooling capacity for your engine. With configurations for Chevy, Ford, and Mopar, they are available in multiple sizes to fit most applications. Combine with our Pro Flow fans and aluminum shrouds for a complete, easy-to-install cooling kit.

ALUMINUM FAN SHROUD KITS



PRODUCT NO.	DESCRIPTION
HC8511	25" Aluminum Fan Shroud & Single 16" Fan Kit
HC8512	23" Aluminum Fan Shroud & Single 16" Fan Kit
HC8513	20" Aluminum Fan Shroud & Single 16" Fan Kit
HC8514	18" Aluminum Fan Shroud & Single 16" Fan Kit
HC8515	16" Aluminum Fan Shroud & Single 16" Fan Kit

PRODUCT NO.	DESCRIPTION
HC8511D	25" Aluminum Fan Shroud & Pro Flow 11" Fan Kit
HC8512D	23" Aluminum Fan Shroud & Pro Flow 11" Fan Kit



PRODUCT NO.	DESCRIPTION
HC9511	25" Aluminum Fan Shroud, Pro Flow 16" Fan & 31" Chevy Radiator Kit
HC9512	23" Aluminum Fan Shroud, Pro Flow 16" Fan & 29" Chevy Radiator Kit

PRODUCT NO.	DESCRIPTION
HC9511D	25" Aluminum Fan Shroud, Pro Flow 11" Fan & 31" Chevy Radiator Kit
HC9512D	23" Aluminum Fan Shroud, Pro Flow 11" Fan & 29" Chevy Radiator Kit



ALUMINUM FAN SHROUDS, SINGLE FAN

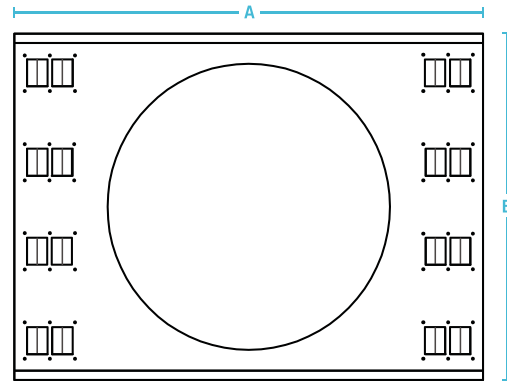
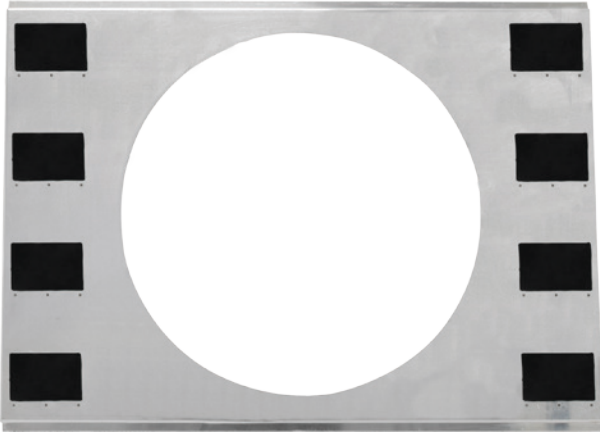

PRODUCT NO.	APPLICATION	DIM. A	DIM. B	CFM
HC7511	Pro Flow 16" Fan	25 3/4"	18 3/4"	2,000
HC7512	Pro Flow 16" Fan	23 3/4"	18 3/4"	2,000

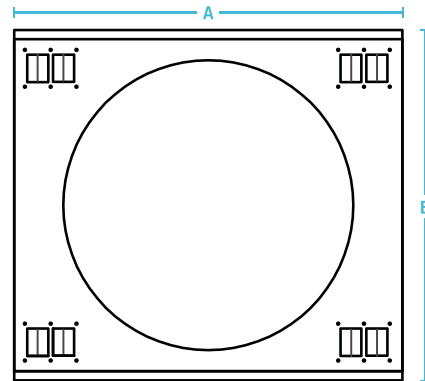
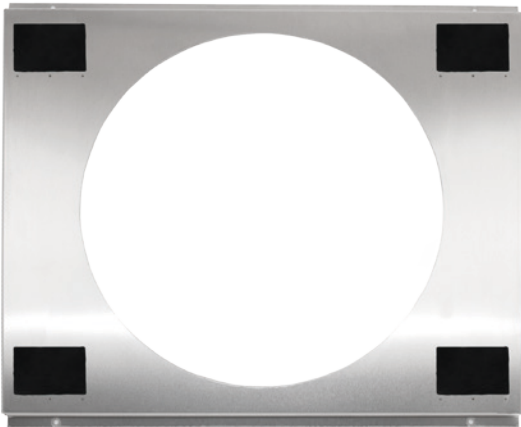

PRODUCT NO.	APPLICATION	DIM. A	DIM. B	CFM
HC7513	Pro Flow 16" Fan	20 3/4"	18 3/4"	2,000
HC7514	Pro Flow 16" Fan	18 3/4"	18 3/4"	2,000
HC7515	Pro Flow 16" Fan	16 3/4"	18 3/4"	2,000

ALUMINUM FAN SHROUDS, DUAL FANS

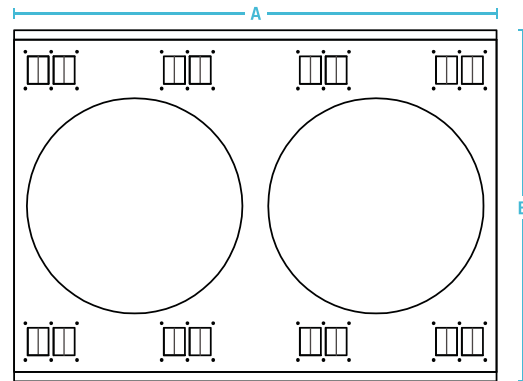
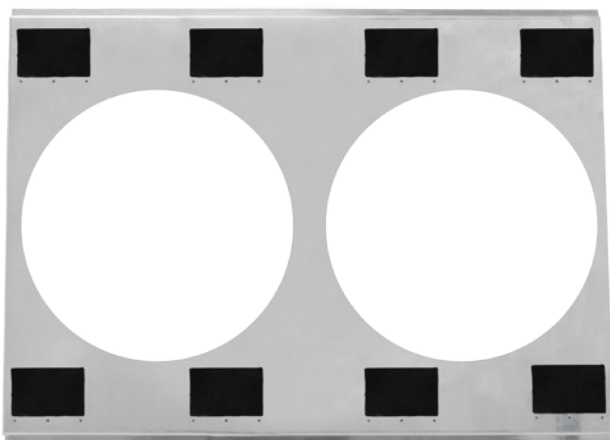

PRODUCT NO.	APPLICATION	DIM. A	DIM. B	CFM
HC7511D	Pro Flow 11" Fan	25 3/4"	18 3/4"	2,800
HC7512D	Pro Flow 11" Fan	23 3/4"	18 3/4"	2,800



CHEVY

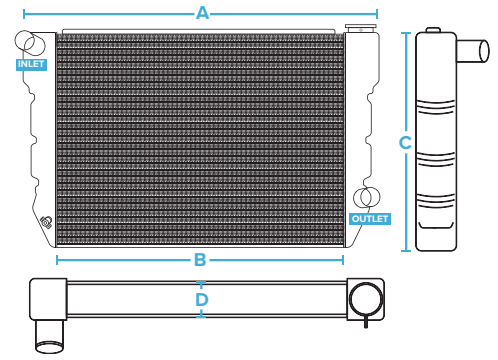

CHEVY RADIATORS	DIM. A (Width)	DIM. B (Width)	DIM. C (Height)	DIM. D (Depth)	INLET	OUTLET
HC6011	31"	26 1/4"	19 1/4"	2 1/4"	1 1/2"	1 3/4"
HC6012	29"	24 1/4"	19 1/4"	2 1/4"	1 1/2"	1 3/4"



HC6201P



HC6304C



HC6310C



HC7599

RADIATOR ACCESSORIES

- HC6201P**
Aluminum Billet Radiator Cap
Polished
- HC6304C**
48" Stainless Steel Radiator Hose Kit
Chrome
- HC6310C**
44" Stainless Steel Heater Hose Kit
Chrome
- HC7599**
Fan Shroud Flap

ELECTRIC COOLING FANS



HC6105

HC6104

HC6103

HC6102

HC6101



HC6105C

HC6104C

HC6103C

HC6102C

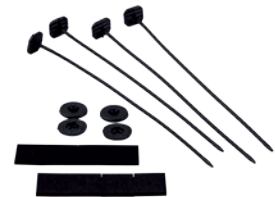

*Mounting kit included

STANDARD FANS

HC6101*

8" Universal Electric Cooling Fan
Straight Blade - Black
*Reversible Straight Blade Design

HC6102*

10" Universal Electric Cooling Fan
S-Blade - Black, Chrome

HC6103*

12" Universal Electric Cooling Fan
S-Blade - Black, Chrome

HC6104*

14" Universal Electric Cooling Fan
S-Blade - Black, Chrome

HC6105*

16" Universal Electric Cooling Fan
S-Blade - Black, Chrome

* Reversible S-Blade design
* Configured as a puller and converts to a pusher

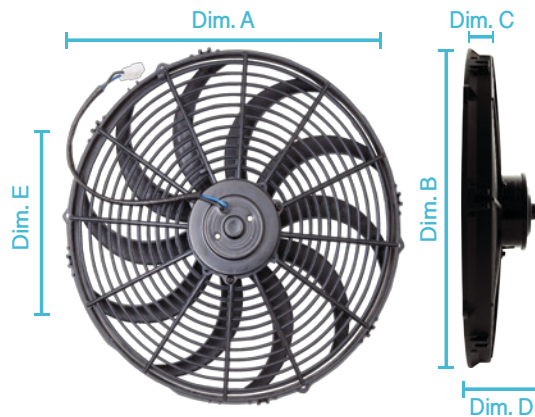

PRODUCT NO.	FAN SIZE	DIM. A	DIM. B	DIM. C	DIM. D	DIM. E
HC6101	8"	8 1/8"	8"	1 1/4"	2 1/4"	4 3/8"
HC6102	10"	11 1/2"	10 3/4"	1 1/2"	2 3/8"	8 7/8"
HC6103	12"	13"	12 1/8"	1 1/2"	2 3/8"	6 3/16"
HC6104	14"	14 7/8"	14"	1 1/2"	3 1/8"	7 1/8"
HC6105	16"	16 1/2"	15 5/8"	1 1/8"	3 5/8"	14"



HC7105

HC7104

HC7103

HC7102



*Mounting kit included

PRODUCT NO.	FAN SIZE	CFM	AMP DRAW	DIM. A	DIM. B	DIM. C	DIM. D	DIM. E
HC7102	10"	650	7.5	10 5/8"	11 1/4"	1 1/4"	2 1/2"	5 5/8"
HC7103	12"	870	10	11 5/8"	11 3/4"	1 3/8"	2 1/2"	6 7/16"
HC7104	14"	1200	12	14 7/16"	15 1/4"	1 3/8"	3 1/2"	7 1/8"
HC7105	16"	1600	14	15 5/8"	16"	1 3/8"	3 3/4"	8 1/8"



HC7106



11" High Performance Dual Electric Cooling Fan, Straight Blade

- Two piece heavy duty shroud
- High output motors

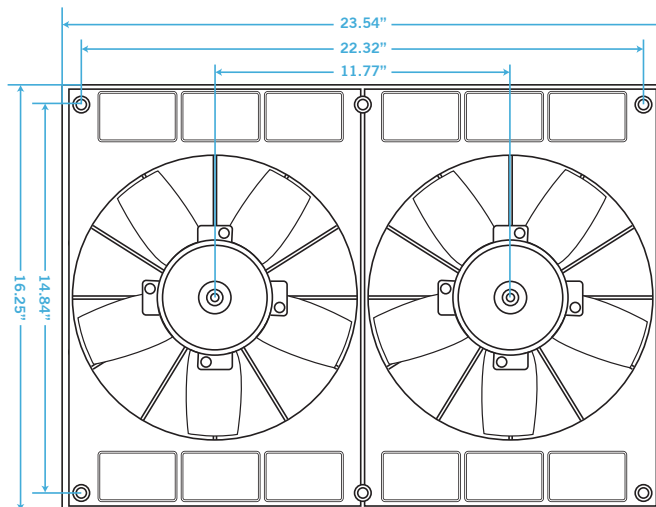

DIMENSIONS ARE IN INCHES

PRO SERIES FANS

HC7102*

10" Pro Series Universal Electric Cooling Fan, 7.5 AMP, S-Blade - Black

HC7103*

12" Pro Series Universal Electric Cooling Fan, 10 AMP, S-Blade - Black

HC7104*

14" Pro Series Universal Electric Cooling Fan, 12 AMP, S-Blade - Black

HC7105*

16" Pro Series Universal Electric Cooling Fan, 14 AMP, S-Blade - Black

HC7106

11" High Performance Dual Electric Cooling Fan, 25 AMP, Straight Blade, Puller, 2,800 CFM - Black

- * Reversible S-Blade design
- * Configured as a puller and converts to a pusher

PRO FLOW FANS

HC7211

11" Pro Flow Universal Electric Cooling Fan, Straight Blade, Puller, 1,400 CFM Black



FAN DIMENSIONS: REFER TO PAGE 156



HC7212

12" Pro Flow Universal Electric Cooling Fan, Straight Blade, Puller, 1,600 CFM Black

HC7211



HC7212



HC7214

14" Pro Flow Universal Electric Cooling Fan, Straight Blade, Puller, 1,800 CFM Black



FAN DIMENSIONS: REFER TO PAGE 155

HC7216

16" Pro Flow Universal Electric Cooling Fan, Straight Blade, Puller, 2,000 CFM Black

HC7214



HC7216



FAN ACCESSORIES

HC6100

HC61XX Series Electric Cooling Fan Mounting Kit Black

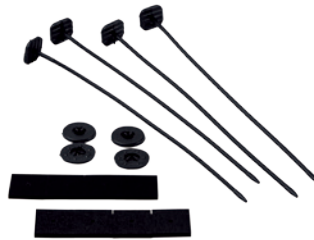

HC7100

HC7102, 03, Electric Cooling Fan Mounting Kit Black

HC7101

HC7105 Electric Cooling Fan Mounting Kit Black

HC7107

HC7104 Electric Cooling Fan Mounting Kit Black

HC7108

Pro Series Electric Fan Relay Wiring Harness Kit, 40-50 AMP 165°-185° F

HC7108W

Pro Series Electric Fan Pigtail

HC6100



HC7100



HC7101



HC7107



HC7108

HC7108W



HC7109

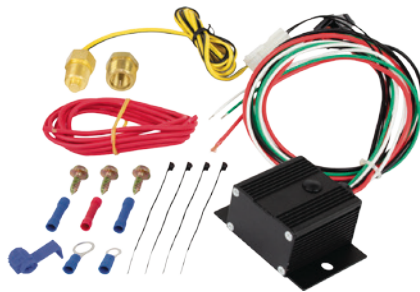

HC7110



HC7109
HC71XX Series Fan Pigtail Harness

HC7110
Adjustable Electric Fan Controller
Wiring Harness Kit, Thread-in
Thermostat, 150°-240° F
Black, Red

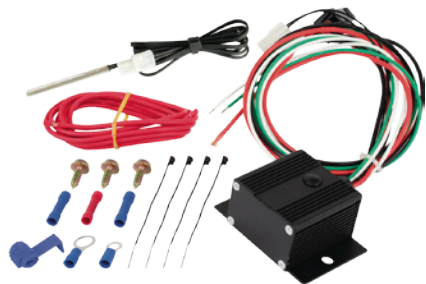

HC7111



HC7111
Adjustable Electric Fan Controller
Wiring Harness Kit, Probe Thermostat,
150°-240° F
Black, Red



HC7112

HC7112
Thread-in Thermostat, 3/8 NPT

HC7113
Radiator Fin Probe Thermostat



HC7113

HC7114
30 AMP Fuse



HC7115
40 AMP Fuse

HC7116
Pro Series 165°-185° F Thermostat,
3/8 NPT

HC7117
40/50 AMP Relay



HC7115

HC7114



HC7116



HC7117

BRACKETS & PULLEYS



CNC Machined



High quality chrome finish

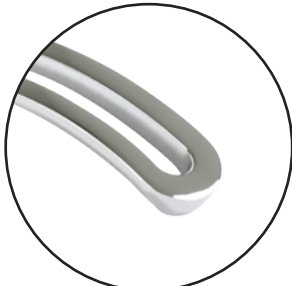

Made Out of Aluminum 6061-T6



JM9105-1 (Improved)
Chevy SB LWP, Aluminum Power
Steering Pump Bracket Kit

TSP's Brackets and Pulleys offer an immediately noticeable upgrade to your engine. We have pulleys available in multiple materials and finishes to match any engine set-up. Our brackets are CNC-machined from 6061-T6 aluminum to ensure precise alignment and stability for your accessories. They come complete with all mounting hardware and are available in multiple premium finishes.



JM9101



JM9102



JM9105



JM9106



JM9116



JM9121



JM9131



JM9103



JM9104



JM9115



CHEVY SMALL BLOCK BRACKET KIT

JM9101

Chevy SB Long Water Pump, Passenger Side, Aluminum Alternator Bracket Kit
Black, Chrome, Polished

JM9102

Chevy SB Short Water Pump, Driver Side, Aluminum Alternator Bracket Kit
Chrome, Polished

JM9105

Chevy SB Long Water Pump, Aluminum Power Steering Pump Bracket Kit
Black, Chrome, Polished

JM9105-1 (Improved)

Chevy SB Long Water Pump, Aluminum Power Steering Pump Bracket Kit
Black, Chrome, Polished

JM9106

Chevy SB Long Water Pump, Driver Side, Aluminum A/C Compressor Bracket Kit
Black, Chrome, Polished

JM9116

Chevy SB Type II Short Water Pump, Steel Power Steering Pump Bracket Kit
Black, Chrome Steel

JM9121

Chevy SB Long Water Pump, High Mount Aluminum Alternator Bracket Kit
Black, Chrome, Polished

JM9131

Chevy SB Long Water Pump, Mid Mount Aluminum Alternator Bracket Kit
Black, Chrome, Polished

CHEVY BIG BLOCK BRACKET KIT

JM9103

Chevy BB Long Water Pump, Passenger Side, Aluminum Alternator Bracket Kit
Black, Chrome, Polished

JM9104

Chevy BB Short Water Pump, Driver Side, Aluminum Alternator Bracket Kit
Chrome, Polished

JM9115

Chevy BB Long Water Pump, Aluminum Power Steering Pump Bracket Kit
Brushed Aluminum, Chrome, Polished

JM9123

Chevy BB Long Water Pump, Aluminum Alternator Bracket Kit
Black, Chrome, Polished



JM9123



JM9133



FORD SMALL BLOCK BRACKET KIT

JM9111

Ford SB 5.0 Reverse Rotation Aluminum Alternator Bracket Kit
Chrome, Polished



JM9111



JM9112



FORD BIG BLOCK BRACKET KIT

JM9114

Ford BB 429 & 460 Aluminum Alternator Bracket Kit
Black, Chrome, Polished



JM9114



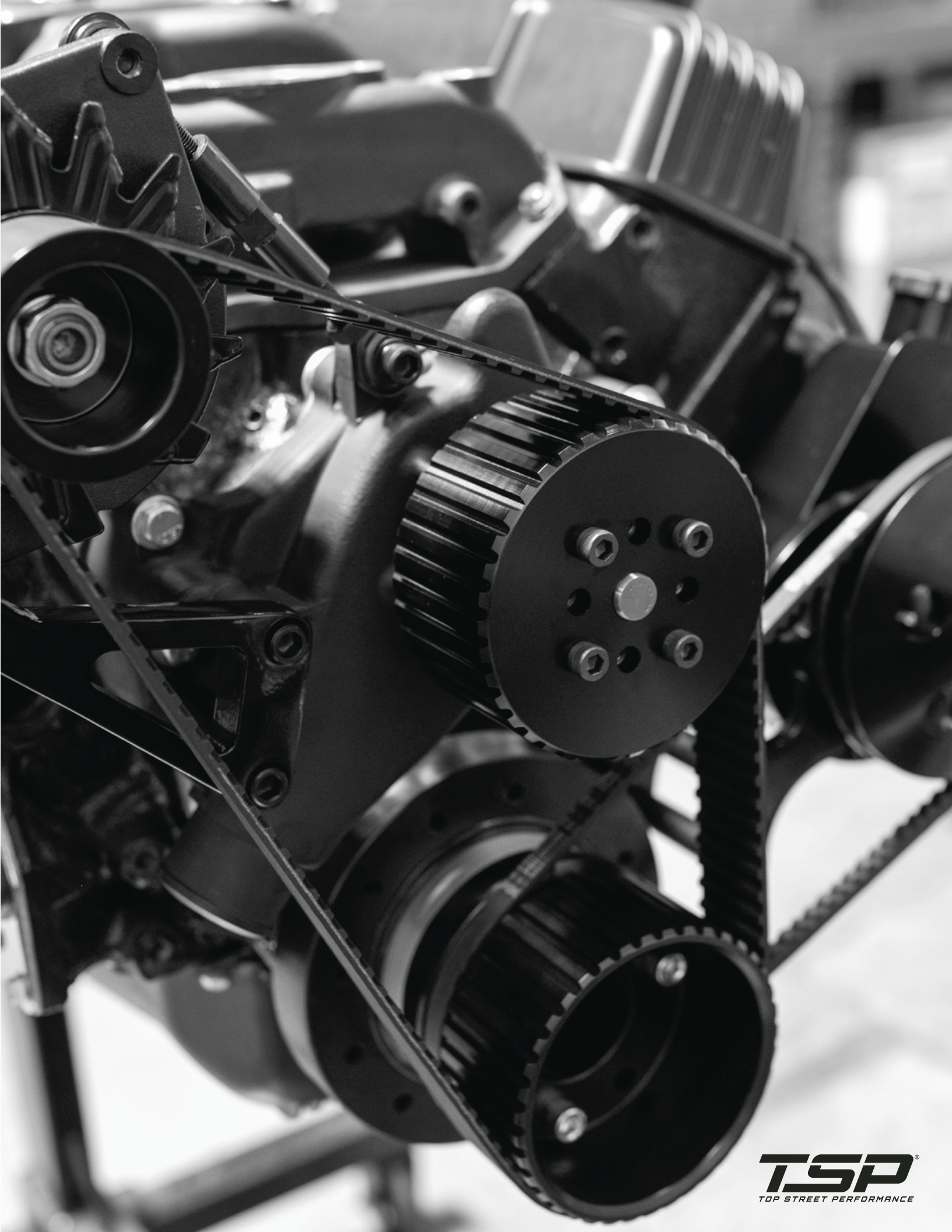

TSP[®]
TOP STREET PERFORMANCE

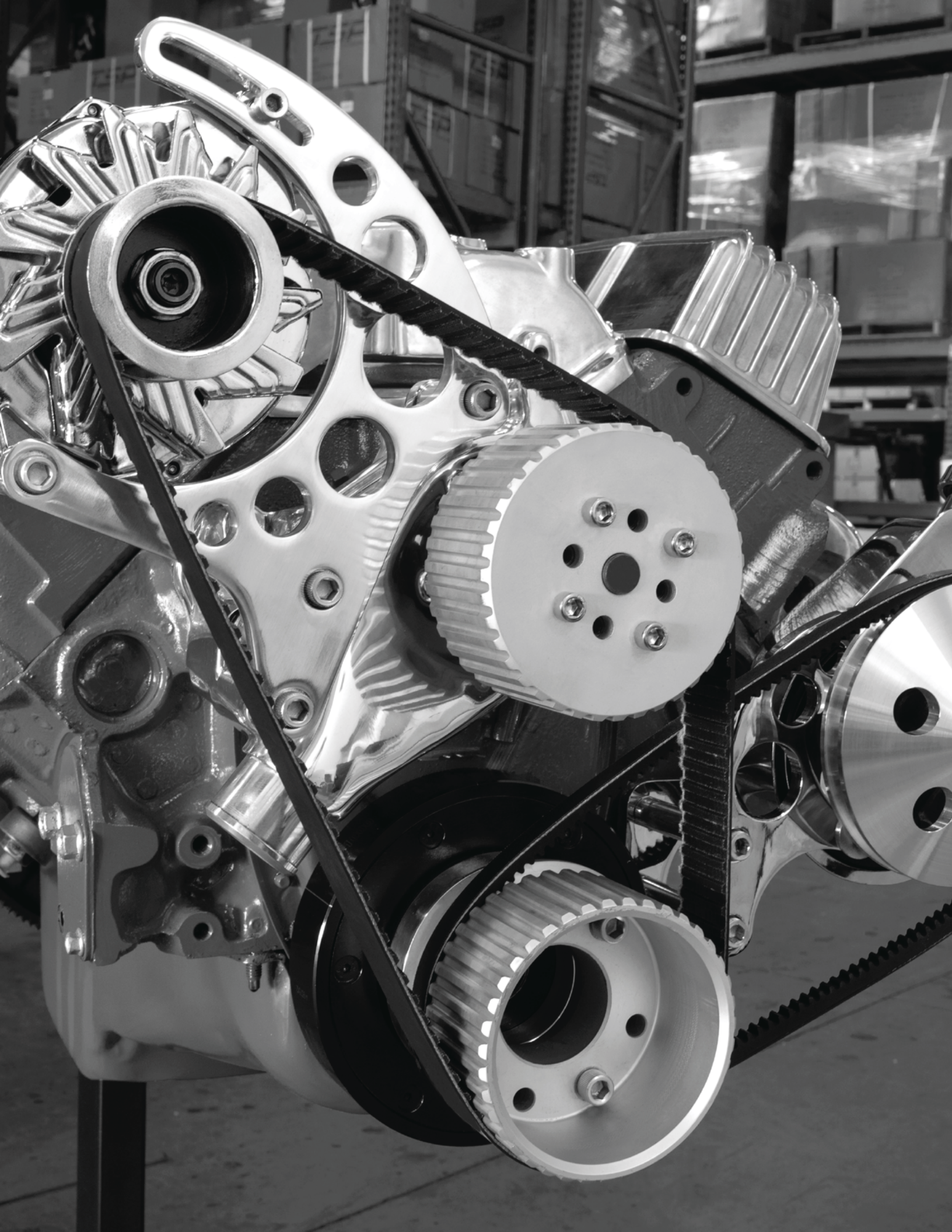

GILMER STYLE PULLEY KIT

Gilmer pulleys are a great solution for any racing set-up. They eliminate the problem of slippage and disengagement you'd experience at high RPM with a V-Belt. Each kit comes with pulleys for the crank, water pump, and alternator, and 1.5" wide belt. Regardless of application, TSP's Gilmer style pulley kit is an efficient and lightweight option for your high-performance engine.



GILMER STYLE PULLEY KIT	DESCRIPTION
10090	Chevy SB V8 Engine Short Water Pump Gilmer Style Pulley Kit
10091	Chevy SB V8 Engine Long Water Pump Gilmer Style Pulley Kit
10092	Chevy BB V8 Engine Short & Long Water Pump Gilmer Style Pulley Kit
10093	Ford SB 302-351W V8 Engine Gilmer Style Pulley Kit
10094	Ford BB 429-460 Gilmer Style Pulley Kit
10095	351 Cleveland Gilmer Style Pulley Kit
10096	Mopar SB 318/340/360 Gilmer Style Pulley Kit
10097	Mopar BB 383-440 Gilmer Style Pulley Kit
10367	36.7" Replacement Belt
10390	39" Replacement Belt
10405	40.5" Replacement Belt
10420	42" Replacement Belt
10450	45" Replacement Belt
10480	48" Replacement Belt
10087	2-3/4" Bolt Kit Only
10088	Chevy SB/BB & Ford SB Gilmer Style Drive 5/8" Crankshaft Spacer with 2-3/4" Bolt Kit



CHEVY SMALL BLOCK LONG WATER PUMP

WATER PUMP

SP8854

Chevy SB Water Pump Pulley,
Single Groove - Aluminum (Natural)



SP8854



SP8856



SP8856

Chevy SB Water Pump Pulley,
Double Groove - Aluminum (Natural)

SP8864

Chevy SB Water Pump Nose Pulley
Aluminum (Natural)



SP8864



SP8855



CRANKSHAFT

SP8855

Chevy SB Crankshaft Pulley,
Single Groove - Aluminum (Natural)

SP8955

Chevy SB Crankshaft Pulley,
Single Groove - Chrome Steel

SP8857

Chevy SB Crankshaft Pulley,
Double Groove - Aluminum (Natural)



SP8857



SP8859



SP8955

Chevy SB Crankshaft Pulley,
Double Groove - Chrome Steel

SP8859

Chevy SB Crankshaft Pulley,
Triple Groove - Aluminum (Natural)

SP8958

Chevy SB Crankshaft Pulley,
Triple Groove - Chrome Steel

POWER STEERING*

*FITS SMALL & BIG BLOCK CHEVY

SP8846

Chevy Power Steering Pulley,
Double Groove - Aluminum (Natural)



SP8958

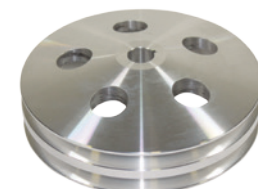

SP8846



SP8848

Chevy Power Steering Pulley, 3/8" V-Belt,
Single Groove - Aluminum (Natural)

SP8848-1

Chevy Power Steering Pulley, 1/2" V-Belt,
Single Groove - Aluminum (Natural)

SP8941

Chevy Press On Power Steering Pulley,
1/2" Single Groove
Black Steel, Chrome Steel



SP8941



SP8948





SP8850



SP8852



SP8863



SP8851

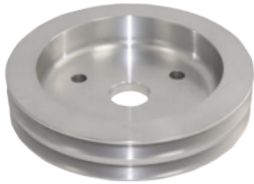

SP8853



SP8953



SP8963



SP8848



SP8943



SP8947



CHEVY SMALL BLOCK SHORT WATER PUMP

WATER PUMP

SP8850

Chevy SB Water Pump Pulley,
Single Groove - Aluminum (Natural)

SP8852

Chevy SB Water Pump Pulley,
Double Groove - Aluminum (Natural)

SP8863

Chevy SB Water Pump Nose Pulley
Aluminum (Natural)

CRANKSHAFT

SP8851

Chevy SB Crankshaft Pulley,
Single Groove - Aluminum (Natural)

SP8951

Chevy SB Crankshaft Pulley,
Single Groove - Chrome Steel

SP8853

Chevy SB Crankshaft Pulley,
Double Groove - Aluminum (Natural)

SP8953

Chevy SB Crankshaft Pulley,
Double Groove - Chrome Steel

SP8858

Chevy SB Crankshaft Pulley,
Triple Groove - Aluminum (Natural)

SP8963

Chevy SB Crankshaft Pulley,
Triple Groove - Chrome Steel

POWER STEERING*

**FITS SMALL & BIG BLOCK CHEVY*

SP8846

Chevy Power Steering Pulley,
Double Groove - Aluminum (Natural)

SP8848

Chevy Power Steering Pulley, 3/8" V-Belt,
Single Groove - Aluminum (Natural)

SP8848-1

Chevy Power Steering Pulley, 1/2" V-Belt,
Single Groove - Aluminum (Natural)

SP8943

Chevy Press On Power Steering Pulley,
3/8" Double Groove
Black Steel, Chrome Steel

SP8947

Chevy Power Steering Pulley,
Double Groove - Chrome Steel

SP8948

Chevy Power Steering Pulley,
Single Groove - Chrome Steel

CHEVY BIG BLOCK LONG WATER PUMP

WATER PUMP

SP8838

Chevy BB Water Pump Pulley,
Double Groove - Aluminum (Natural)

SP8960

Chevy BB Water Pump Pulley,
Double Groove - Chrome Steel

CRANKSHAFT

SP8839

Chevy BB Crankshaft Pulley,
Triple Groove - Aluminum (Natural)

SP8961

Chevy BB Crankshaft Pulley,
Triple Groove - Chrome Steel

POWER STEERING*

REFER TO PAGE 93 OR 94

CHEVY BIG BLOCK SHORT WATER PUMP

WATER PUMP

SP8840

Chevy BB Water Pump Pulley,
Single Groove - Aluminum (Natural)

SP8842

Chevy BB Water Pump Pulley,
Double Groove - Aluminum (Natural)

SP8964

Chevy BB Water Pump Pulley, Double
Groove, Vented Style - Chrome Steel

CRANKSHAFT

SP8841

Chevy BB Crankshaft Pulley,
Single Groove - Aluminum (Natural)

SP8966

Chevy BB Crankshaft Pulley,
Single Groove - Chrome Steel

SP8843

Chevy BB Crankshaft Pulley,
Double Groove - Aluminum (Natural)

SP8965

Chevy BB Crankshaft Pulley,
Double Groove - Chrome Steel

SP8849

Chevy BB Crankshaft Pulley,
Triple Groove - Aluminum (Natural)

POWER STEERING*

REFER TO PAGE 93 OR 94



SP8960



SP8961



SP8840



SP8842



SP8964



SP8841



SP8966

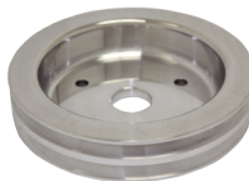

SP8843



SP8965



SP8849





SP8970



SP8975



SP8973



SP8971



SP8974



SP8972



FORD SMALL BLOCK

WATER PUMP

SP8970

Ford SB Water Pump Pulley,
Single Groove - Chrome Steel

SP8975

Ford SB Water Pump Pulley,
Double Groove - Chrome Steel

SP8973

Ford SB Water Pump Pulley,
Triple Groove - Chrome Steel

CRANKSHAFT

SP8971

Ford SB Crankshaft Pulley,
Single Groove - Chrome Steel

SP8974

Ford SB Crankshaft Pulley,
Double Groove - Chrome Steel

SP8972

Ford SB Crankshaft Pulley, Triple Groove
Chrome Steel

INTAKE MANIFOLDS



Four corner water ports



Special manifold adapters

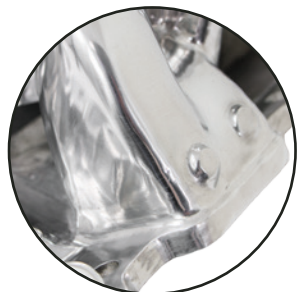

Big gains from 1,500 - 6,500 RPM

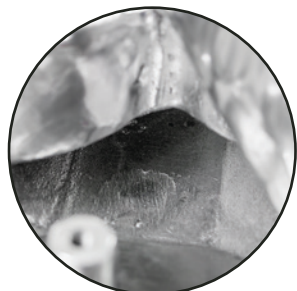

Open area under the plenum



82025
Chevy SB Dual Plane Air Gap
Intake Manifold, Fits 1957-1995

TSP's dual plane intake manifold is a great addition to any performance engine. With upgrades throughout, it will increase your horsepower and give you more options on the top-end. They are available in the standard style, as well as air-gap style for even better performance, and they come in multiple finishes for several applications.

INTAKE MANIFOLDS

CHEVY SMALL BLOCK INTAKE MANIFOLD

82000

Chevy SB Stock Dual Plane Intake Manifold, Fits 1957-1995 Polished

82001

Chevy SB Stock Dual Plane Intake Manifold, Fits 1957-1995 Black, Satin

82007

Chevy SB V8 Vortec Dual Plane Intake Manifold, Fits 1996-Later Satin

82025

Chevy SB Dual Plane Air Gap Intake Manifold, Fits 1957-1995 Polished

82026

Chevy SB Dual Plane Air Gap Intake Manifold, Fits 1957-1995 Black, Satin

CHEVY BIG BLOCK INTAKE MANIFOLD

83000

Chevy BB Stock Dual Plane Intake Manifold, Oval Port Polished

83001

Chevy BB Stock Dual Plane Intake Manifold, Oval Port Black, Satin

83025

Chevy BB Stock Dual Plane Air Gap Intake Manifold Polished

83026

Chevy BB Stock Dual Plane Air Gap Intake Manifold Black, Satin

FORD SMALL BLOCK INTAKE MANIFOLD

84000

Ford SB Dual Plane Intake Manifold Polished

84001

Ford SB Dual Plane Intake Manifold Black, Satin



82000



82001



82007

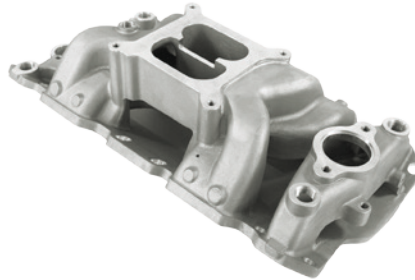

82026



83000



83001



83025

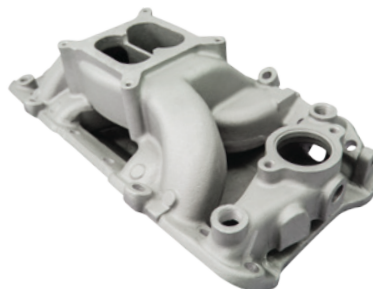

83026



84000



84001



FORD SMALL BLOCK INTAKE MANIFOLD

84022

Ford SB 351 Windsor Dual Plane
Intake Manifold
Polished



84022



84023



84023

Ford SB 351 Windsor Dual Plane
Intake Manifold
Satin

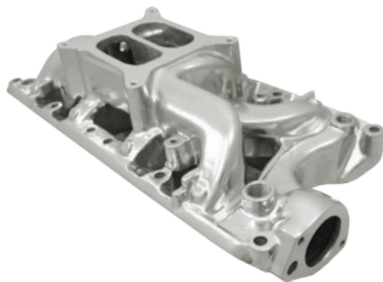

84025

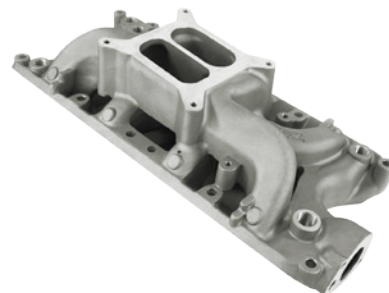

84026



84025

Ford SB Dual Plane Air Gap
Intake Manifold
Polished

84026

Ford SB Dual Plane Air Gap
Intake Manifold
Satin

FENDER COVERS

PRODUCT NO. CB8002

TSP's premium fender covers are a great and stylish way to protect your ride while you work in the engine bay. With a soft, foam backing, they fit over the fender with ease and won't damage your paint job. They feature magnetic holders for a secure fit, and the easy-to-clean, vinyl finish features a bold, red TSP logo. Measuring 52" x 26", they come in pairs for full fender protection.



HARMONIC BALANCERS



30000

Chevy SB 350, 6-3/4" SFI Certified Harmonic Balancer

sfi SFI FOUNDATION INC. This Mfr. Certifies That This Product Meets 18.1 Read Mfr. Instructions Before Install

SPEC 18.1
A 937510

TSP's Harmonic Balancers provide unbeatable performance and durability. Utilizing superior internal design and accurate balancing, they are built to handle your high-performance engine with ease. Also featured are easy-to-read, white on black timing marks for simple installation. They are precisely machined for a perfect fit and are available for many applications.

HARMONIC BALANCERS

30000

Chevy SB 350, 6-3/4" SFI Certified Harmonic Balancer
Satin Black



31000



30001



31000

Chevy SB 350, 6-3/4" SFI Certified Harmonic Balancer
Gloss Black



30002



30003



30001

Chevy SB 400, 6-3/4" SFI Certified Harmonic Balancer
Satin Black

30002

Chevy SB 350, 8" SFI Certified Harmonic Balancer
Satin Black



30004



31004



30003

Chevy SB 400, 8" SFI Certified Harmonic Balancer
Satin Black

30004

Chevy BB 396/427, 8" SFI Certified Harmonic Balancer
Satin Black



30005



30006



31004

Chevy BB 396/427, 8" SFI Certified Harmonic Balancer
Gloss Black

30005

Chevy BB 454/502, 8" SFI Certified Harmonic Balancer
Satin Black

30006

Ford SB Early, 6.4" Harmonic Balancer
Satin Black

30007

Ford SB Late, 6.4" Harmonic Balancer
Satin Black



30007



30008



30008

Ford 429, 6.7" Harmonic Balancer
Satin Black

ROCKER ARMS



Needle bearing fulcrum and roller tip



External thrust washer



Opening spring pressures up to 900 LBS



CNC 2024 aluminum body

TSP's Rocker Arms are produced to the highest quality, featuring precision machining and design details that ensure long-lasting reliability in performance applications. Available types include stud and shaft mounted rockers, CNC machined from 2024 billet aluminum, as well as premium stainless steel. They are offered for multiple applications from small and big block Chevy and Ford, Pontiac V8, LS1 and LS3.

ALUMINUM ROCKER ARMS

PRODUCT NO.	DESCRIPTION
74503	Chevy SB 2024 Aluminum 1.5 Ratio, 3/8 Rocker Arm
74507	Chevy SB 2024 Aluminum 1.5 Ratio, 7/16 Rocker Arm
74603	Chevy SB 2024 Aluminum 1.6 Ratio, 3/8 Rocker Arm
74607	Chevy SB 2024 Aluminum 1.6 Ratio, 7/16 Rocker Arm
75707	Chevy BB 2024 Aluminum 1.7 Ratio, 7/16 Rocker Arm
75727	Chevy BB 2024 Aluminum 1.72 Ratio, 7/16 Rocker Arm
75807	Chevy BB 2024 Aluminum 1.8 Ratio, 7/16 Rocker Arm
71700	LS1/LS2/LS6 2024 Aluminum 1.7 Ratio Rocker Arm
71800	LS1/LS2/LS6 2024 Aluminum 1.8 Ratio Rocker Arm
73700	LS3/L92 2024 Aluminum 1.7 Ratio Rocker Arm
73800	LS3/L92 2024 Aluminum 1.8 Ratio Rocker Arm
78657	Pontiac 2024 Aluminum 1.65 Ratio, 7/16 Rocker Arm
78737	Pontiac 2024 Aluminum 1.73 Ratio, 7/16 Rocker Arm
76603	Ford SB 2024 Aluminum 1.6 Ratio, 3/8 Rocker Arm
76607	Ford SB 2024 Aluminum 1.6 Ratio, 7/16 Rocker Arm
76703	Ford SB 2024 Aluminum 1.7 Ratio, 3/8 Rocker Arm
76707	Ford SB 2024 Aluminum 1.7 Ratio, 7/16 Rocker Arm
77737	Ford BB 2024 Aluminum 1.73 Ratio, 7/16 Rocker Arm

ROCKER ARMS

ALUMINUM SHAFT MOUNT ROCKER ARMS

PRODUCT NO.	DESCRIPTION
7170S	LS1/LS2/LS6 2024 Aluminum 1.7 Ratio, Shaft Mounted Rocker Arm
7180S	LS1/LS2/LS6 2024 Aluminum 1.8 Ratio, Shaft Mounted Rocker Arm
7370S	LS3/L92 2024 Aluminum 1.7 Ratio, Shaft Mounted Rocker Arm
7380S	LS3/L92 2024 Aluminum 1.8 Ratio, Shaft Mounted Rocker Arm

STAINLESS STEEL ROCKER ARMS

PRODUCT NO.	DESCRIPTION
74503SS	Chevy SB Stainless Steel 1.5 Ratio, 3/8 Rocker Arm
74507SS	Chevy SB Stainless Steel 1.5 Ratio, 7/16 Rocker Arm
74603SS	Chevy SB Stainless Steel 1.6 Ratio, 3/8 Rocker Arm
74607SS	Chevy SB Stainless Steel 1.6 Ratio, 7/16 Rocker Arm
75707SS	Chevy BB Stainless Steel 1.7 Ratio, 7/16 Rocker Arm
75727SS	Chevy BB Stainless Steel 1.72 Ratio, 7/16 Rocker Arm
75807SS	Chevy BB Stainless Steel 1.8 Ratio, 7/16 Rocker Arm
71700SS	LS1/LS2/LS6 Stainless Steel 1.7 Ratio Rocker Arm
71800SS	LS1/LS2/LS6 Stainless Steel 1.8 Ratio Rocker Arm
73700SS	LS3/L92 Stainless Steel 1.7 Ratio Rocker Arm
73800SS	LS3/L92 Stainless Steel 1.8 Ratio Rocker Arm
78657SS	Pontiac Stainless Steel 1.65 Ratio, 7/16 Rocker Arm
78737SS	Pontiac Stainless Steel 1.73 Ratio, 7/16 Rocker Arm
76603SS	Ford SB Stainless Steel 1.6 Ratio, 3/8 Rocker Arm
76607SS	Ford SB Stainless Steel 1.6 Ratio, 7/16 Rocker Arm
76703SS	Ford SB Stainless Steel 1.7 Ratio, 3/8 Rocker Arm
76707SS	Ford SB Stainless Steel 1.7 Ratio, 7/16 Rocker Arm
77737SS	Ford BB Stainless Steel 1.73 Ratio, 7/16 Rocker Arm
71000	LS 1.7 Ration Upgrade Needle Bearing Trunion Kit



ALUMINUM STUD GIRDLE

PRODUCT NO.	DESCRIPTION
74003	Chevy SB 2024 Aluminum 3/8 Stud Girdle
74007	Chevy SB 2024 Aluminum 7/16 Stud Girdle
75007	Chevy BB 2024 Aluminum 7/16 Stud Girdle
76003	Ford 2024 Aluminum 3/8 Stud Girdle
76007	Ford 2024 Aluminum 7/16 Stud Girdle



VALVE COVERS



JM8082-1

LS Aluminum Tall Cast Valve Cover,
Center Bolt with Coil Mounts, Oil Filler Hole

VALVE COVER DIMENSION: REFER TO PAGE 167

JM8082-2

LS Aluminum Finned Cast Valve Cover
and Coil Cover, Center Bolt with Coil Mounts

***IGNITION COILS SOLD SEPARATELY**

VALVE COVER DIMENSION: REFER TO PAGE 167



TSP's Valve Covers are constructed of high-quality materials and are available for any look and application. We've got cast aluminum valve covers for the classic or retro look and fabricated aluminum for racing. Our fabricated covers feature CNC-machined rails and are completely TIG welded. They offer excellent stability and valve train clearance along with great looks.

VALVE COVERS

LS VALVE COVER

JM8081-5

LS Aluminum Fabricated Valve Cover, Center Bolt without Coil Mounts, Oil Filler Hole
Black, Clear Anodized, Polished



JM8081-5



JM8081-6



JM8081-6

LS Aluminum Fabricated Valve Cover, Center Bolt with Coil Mounts, Oil Filler Hole
Black, Clear Anodized, Polished

JM8081-7

LS Aluminum Fabricated Coil Cover, Center Bolt with Billet Oil Filler Neck, Patent # D735759
Black, Clear Anodized, Polished



JM8081-7



JM8082-3



JM8082-1

LS Aluminum Tall Cast Valve Cover, Center Bolt with Coil Mounts, Oil Filler Hole
Black, Polished, Satin

JM8082-2

LS Aluminum Finned Cast Valve Cover and Coil Cover, Center Bolt with Coil Mounts
Black, Polished, Satin

JM8082-3

LS Aluminum Smooth Cast Valve Cover and Coil Cover, Center Bolt with Coil Mounts
Black, Polished, Satin



CHEVY VALVE COVER

JM8072-2

Chevy SB Aluminum Tall Fabricated Valve Cover, Center Bolt without Breather Hole
Clear Anodized, Polished

JM8072-2



JM8091-2



JM8091-2

Chevy SB Aluminum Tall Fabricated Valve Cover, Long Bolt without Breather Hole
Clear Anodized, Polished

JM8091-3

Chevy SB Aluminum Tall Fabricated Valve Cover, Short Bolt without Breather Hole
Clear Anodized, Polished

JM8091-3



JM8091-7



JM8091-7

Chevy SB Aluminum Tall Fabricated Valve Cover, Long Bolt with Breather Hole
Clear Anodized, Polished

JM8091-8

Chevy SB Aluminum Tall Fabricated Valve Cover, Short Bolt with Breather Hole
Black, Clear Anodized, Polished

JM8092-2

Chevy BB Aluminum Tall Fabricated Valve Cover, Long Bolt without Breather Hole
Clear Anodized, Polished

JM8091-8



JM8092-2



CHEVY VALVE COVER

JM8092-3

Chevy BB Aluminum Tall Fabricated Valve Cover, Short Bolt without Breather Hole
Chrome, Clear Anodized, Polished



JM8092-3



JM8092-7



JM8092-7

Chevy BB Aluminum Tall Fabricated Valve Cover, Long Bolt with Breather Hole
Clear Anodized, Polished

JM8092-8

Chevy BB Aluminum Tall Fabricated Valve Cover, Short Bolt with Breather Hole
Black, Chrome, Clear Anodized, Polished



JM8092-8



JM8111-8



JM8111-8

Chevy SB Aluminum Tall Smooth Die Cast Valve Cover, Short Bolt with Breather Hole
Polished

JM8112-8

Chevy BB Aluminum Tall Smooth Die Cast Valve Cover, Short Bolt with Breather Hole
Polished



JM8112-8



JM8121-8



JM8121-8

Chevy SB Aluminum Tall Ball-Milled Die Cast Valve Cover, Short Bolt with Breather Hole
Polished

JM8122-8

Chevy BB Aluminum Tall Ball-Milled Die Cast Valve Cover, Short Bolt with Breather Hole
Polished



JM8122-8



JM8501-6



JM8501-6

Chevy SB Aluminum Tall Finned Die Cast Valve Cover, Center Bolt with Breather Hole
Polished

JM8501-8

Chevy SB Aluminum Tall Finned Die Cast Valve Cover, Short Bolt with Breather Hole
Polished



JM8501-8



JM8502-8



JM8502-8

Chevy BB Aluminum Tall Finned Die Cast Valve Cover, Short Bolt with Breather Hole
Polished

**JM8041-7****JM8041-8****JM8093-2****JM8093-3****JM8093-7****JM8093-8****JM8094-2****JM8094-3****JM8094-7****JM8094-8**

FORD VALVE COVER

JM8041-7

Ford SB 5.0L EFI Aluminum Tall Tapered Fabricated Valve Cover, Long Bolt with Breather Hole
Clear Anodized, Polished

JM8041-8

Ford SB 5.0L EFI Aluminum Tall Tapered Fabricated Valve Cover, Short Bolt with Breather Hole
Clear Anodized, Polished

JM8093-2

Ford SB Aluminum Tall Fabricated Valve Cover, Long Bolt without Breather Hole
Clear Anodized, Polished

JM8093-3

Ford SB Aluminum Tall Fabricated Valve Cover, Short Bolt without Breather Hole
Clear Anodized, Polished

JM8093-7

Ford SB Aluminum Tall Fabricated Valve Cover, Long Bolt with Breather Hole
Clear Anodized, Polished

JM8093-8

Ford SB Aluminum Tall Fabricated Valve Cover, Short Bolt with Breather Hole
Clear Anodized, Polished

JM8094-2

Ford BB Aluminum Tall Fabricated Valve Cover, Long Bolt without Breather Hole
Clear Anodized, Polished

JM8094-3

Ford BB Aluminum Tall Fabricated Valve Cover, Short Bolt without Breather Hole
Clear Anodized, Polished

JM8094-7

Ford BB Aluminum Tall Fabricated Valve Cover, Long Bolt with Breather Hole
Clear Anodized, Polished

JM8094-8

Ford BB Aluminum Tall Fabricated Valve Cover, Short Bolt with Breather Hole
Clear Anodized, Polished

FORD FE VALVE COVER

JM8098-3

Ford FE Aluminum Tall Fabricated Valve Cover, Short Bolt without Breather Hole
Clear Anodized, Polished



JM8098-3



JM8098-7



JM8098-7

Ford FE Aluminum Tall Fabricated Valve Cover, Long Bolt with Breather Hole
Clear Anodized, Polished

JM8098-8

Ford FE Aluminum Tall Fabricated Valve Cover, Short Bolt with Breather Hole
Clear Anodized, Polished



JM8098-8



JM8096-7



MOPAR VALVE COVER

JM8096-7

Mopar SB Aluminum Tall Fabricated Valve Cover, Long Bolt with Breather Hole
Clear Anodized, Polished

JM8097-7

Mopar BB Aluminum Tall Fabricated Valve Cover, Long Bolt with Breather Hole
Clear Anodized, Polished



JM8097-7



JM8097-8

Mopar BB Aluminum Tall Fabricated Valve Cover, Short Bolt with Breather Hole
Clear Anodized, Polished



JM8097-8



**JM8591-8**

ALUMINUM FINNED FABRICATED VALVE COVERS

TSP's fabricated valve covers now come in a new, finned style. Like our standard smooth variety, they are constructed of premium aluminum with beautiful TIG welding for a solid seal, and if you're looking for a unique way to dress-up that top-end, these finned fabricated aluminum valve covers are sure to do the trick.

**JM8592-8****JM8593-8****JM8595-8****JM8598-8****JM8599-3**

CHEVY VALVE COVER

JM8591-8

Chevy SB Aluminum Tall Finned Fabricated Valve Cover, Short Bolt with Breather Hole
Black, Clear Anodized

JM8592-8

Chevy BB Aluminum Tall Finned Fabricated Valve Cover, Short Bolt with Breather Hole
Black, Clear Anodized

FORD SB VALVE COVER

JM8593-8

Ford SB Aluminum Tall Finned Fabricated Valve Cover, Short Bolt with Breather Hole
Black, Clear Anodized

PONTIAC VALVE COVER

JM8595-8

Pontiac 326-455 Aluminum Tall Finned Fabricated Valve Cover, Short Bolt with Breather Hole
Black, Clear Anodized

FORD FE VALVE COVER

JM8598-8

Ford FE Aluminum Tall Finned Fabricated Valve Cover, Short Bolt with Breather Hole
Black, Clear Anodized

AMC/JEEP VALVE COVER

JM8599-3

AMC/Jeep 304-390 Aluminum Tall Finned Fabricated Valve Cover, Short Bolt without Breather Hole
Black, Clear Anodized

VALVE COVER GASKETS

CHEVY VALVE COVER GASKET

SP7483

Chevy SB 265-400, 1955-1993
3/16" Cork Valve Cover Gasket

SP7484

Chevy SB 265-400, 1955-1993
3/16" Rubber with Steel Valve
Cover Gasket

SP7489

Chevy SB 5.0L-5.7L, 1987-Up
1/8" Black Rubber Valve Cover Gasket

SP6120

Chevy BB 396-502, 1965-1995
1/8" Cork Valve Cover Gasket

SP6121

Chevy BB 396-502, 1965-1995
3/16" Rubber with Steel Valve
Cover Gasket

FORD VALVE COVER GASKET

SP6122

Ford SB 260-351 Windsor, 1962-1991
3/16" Cork Valve Cover Gasket

SP6123

Ford SB 260-351 Windsor, 1962-1991
3/16" Rubber with Steel Valve
Cover Gasket

SP6112

Ford P/U Truck (L/A) 360-390,
1968-1979, Ford Car 1961-1971
3/16" Rubber with Steel Valve
Cover Gasket

SP6111

Ford 351 Cleveland & 400M 1970-1982
Car & Light Duty Truck 3/16" Rubber
with Steel Valve Cover Gasket

SP6124

Ford BB 429-460, 1968-1987 Car & Truck
3/16" Cork Valve Cover Gasket

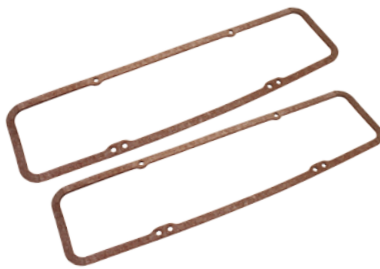

SP7483

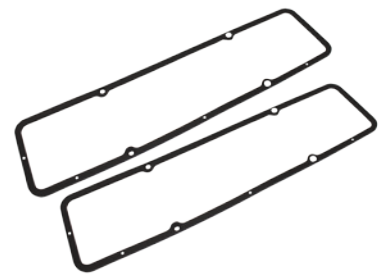

SP7484

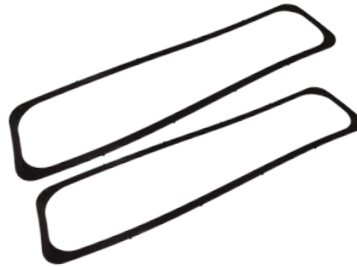

SP7489

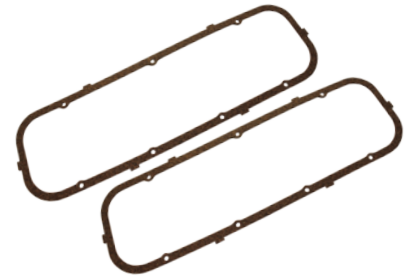

SP6120

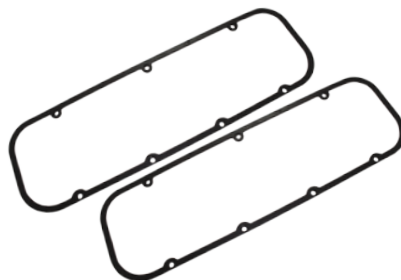

SP6121

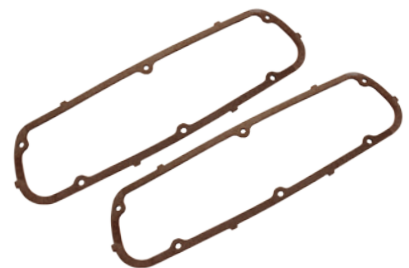

SP6122

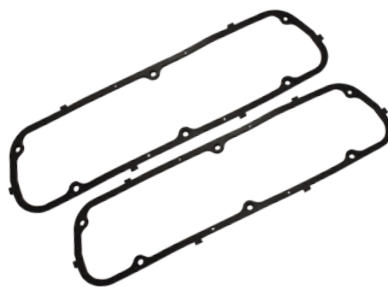

SP6123



SP6112

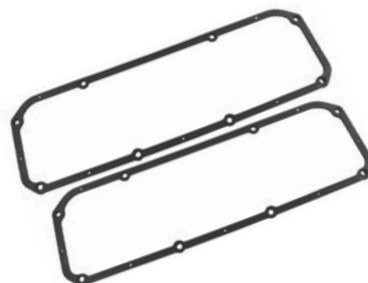

SP6111

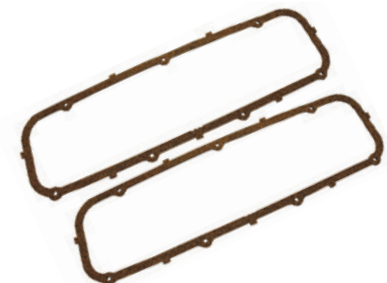

SP6124



SP6113

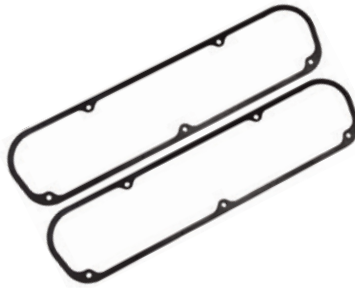

SP6114

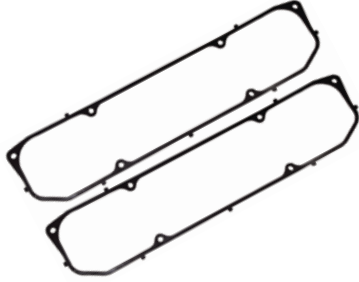

SP6115

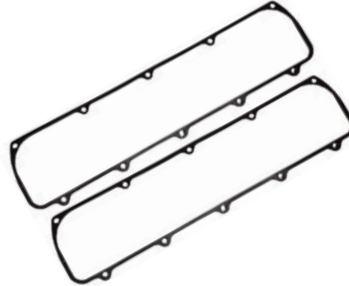

SP6110

SP6113

Ford BB 429-460, 1968-1987 Car & Truck
3/16" Rubber with Steel Valve Cover
Gasket

**CHRYSLER VALVE
COVER GASKET****SP6114**

Chrysler 318-340-360, 1957-1989
3/16" Rubber with Steel Valve
Cover Gasket

SP6115

Chrysler 383-440 Wedge, 1959-1978
3/16" Rubber with Steel Valve
Cover Gasket

**OLDSMOBILE VALVE
COVER GASKET****SP6110**

Oldsmobile 260-307-330-350-400-403-
425-455, 1964-1990 3/16" Rubber with
Steel Valve Cover Gasket

DIFFERENT VALVE COVER GASKET MATERIAL*CORK**RUBBER WITH STEEL**BLACK RUBBER*

PUSH-IN BREATHERS

SP8489

Plain Polished Aluminum Push-in Breather with 3/4" Neck PCV Valve



SP8489

SP8486

Oval Finned Polished Aluminum Push-in Breather

**Available in Black Finish*



SP8486

SP8487

Oval Finned Polished Aluminum Push-in Breather with PCV Valve

**Available in Black Finish*



SP8487

SP7187

High Performance Washable Push-in Breather, 2" Tall without Lip



SP7187

SP7198

High Performance Washable Push-in Breather, Fits any 1-1/4" Hole

SP7192

High Performance Washable Push-in Breather, 2" Short, Fits any 1-1/4" Hole



SP7198

SP7177

High Performance Washable Push-in Breather, Fits any 1" Hole



SP7192

SP7191

High Performance Washable Push-in Breather with Shield, Fits any 1-1/4" Hole

HIGH PERFORMANCE WASHABLE BREATHERS

SP7181

High Performance Washable Clamp-On Breather, Fits 1-3/8" Tube



SP7197

SP7180

High Performance Washable Clamp-On Breather with Shield, Fits 1-3/8" Tube



SP7191



SP7181



SP7180



SP7188



SP7186



SP7490



SP7184



SP7482-0



SP7257



SP7151



SP7147



SP4355



SP4360

SP7188

High Performance Washable Clamp-On Breather, Fits 1-1/2" Tube

SP7186

High Performance Washable Clamp-On Breather with Shield, Fits 1-1/2" Tube

OIL PLUGS & CAP

SP7490

Push-In Oil Filler Plug (No Logo)

SP7184

Push-In Plug (No Logo)

SP7482-0

Push-In Plug (with Oil Logo)

SP7257

Twist-On OEM Style Cap

AIR CLEANER KITS

SP7151

Chrome Steel 4" Deep Dish "Mini" Air Cleaner with Paper Kit, 3-1/4" Height

SP7147

Chrome Steel 4" Louvered "Mini" Air Cleaner with Paper Kit, 3-1/8" Height

SP4355

Chrome Steel 6" Muscle Car Air Cleaner with Paper Kit, 2-7/8" Height

SP4360

Chrome Steel 10" Muscle Car Air Cleaner with Paper Kit, 3-1/2" Height

OIL PANS

SP8442

Chevy SB 265-350, 1955-1979
4-QT Rear Sump Finned Aluminum Oil Pan, Driver Side Dipstick
Black, Polished



SP8442



SP8445

SP8445

Ford SB 260-302, 1962-1995
4-QT Front Sump Finned Aluminum Oil Pan, Passenger Side Dipstick
Polished



SP7442



SP7443

SP7442

Chevy SB 283-400, 1957-1974
4-QT Rear Sump Steel Oil Pan, Driver Side Dipstick
Black, Chrome, Orange, Unplated, Zinc

SP7443

Chevy SB 305-350, 1967-1993
4-QT Rear Sump Steel Oil Pan, Passenger Side Dipstick
Chrome, Unplated, Zinc

SP7441

Chevy SB 305-350, 1986-Up
4-QT Rear Sump Steel Oil Pan, Passenger Side Dipstick
Chrome, Unplated, Zinc



SP7475

Chevy SB 305-350, 1967-1993
4-QT Rear Sump Steel Oil Pan, Passenger Side Dipstick
Black

SP7441

SP7475

SP7480

Chevy SB 283-350, 1962-1967
6-QT Rear Sump Steel Oil Pan
Unplated

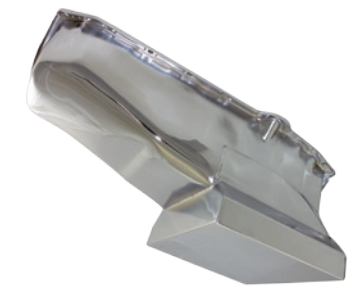

SP7430

Chevy SB 283-400, 1957-1976
7-QT Rear Sump Steel Oil Pan
Chrome

SP7480

SP7430

SP7435

Chevy SB 283-400, 1957-1976
7-QT Rear Sump Steel Oil Pan
Orange



SP7444

Chevy BB 396-454, 1965-1976
4-QT Rear Sump Steel Oil Pan, Passenger Side Dipstick
Black, Chrome, Unplated, Zinc

SP7435

SP7444



SP7432



SP7437



SP7445



SP7457



SP7454



SP7452

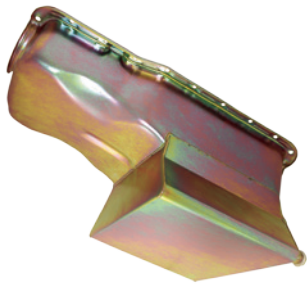

SP7474



SP7450



SP7451



SP7446

SP7432

Chevy BB 396-454, 1965-1976
6-QT Rear Sump Steel Oil Pan,
Passenger Side Dipstick
Chrome

SP7437

Chevy BB 396-454, 1965-1976
6-QT Rear Sump Steel Oil Pan,
Passenger Side Dipstick
Orange

SP7445

Ford SB 260-302, 1962-1995
4-QT Front Sump Steel Oil Pan,
Timing Cover Dipstick
Chrome, Unplated, Zinc

SP7457

Ford SB 302 (5.0L), 1985-1993 Mustang
4-QT Dual Sump Steel Oil Pan
Chrome, Unplated

SP7454

Ford SB 351 Cleveland, 351M, 400,
1970-1979 4-QT Front Sump Steel
Oil Pan
Chrome, Unplated, Zinc

SP7452

Ford 351 Windsor, 1969-1991
4-QT Front Sump Steel Oil Pan,
Timing Cover Dipstick
Chrome, Unplated, Zinc

SP7474

Ford SB 260-302, 1962-1995
7-QT Front Sump Steel Oil Pan,
Timing Cover Dipstick
Zinc

SP7450

Ford BB 352-428, 1958-1970
4-QT Front Sump Steel Oil Pan,
Timing Cover Dipstick
Chrome, Unplated, Zinc

SP7451

Ford BB 429-460, 1968-1978
4-QT Front Sump Steel Oil Pan,
Timing Cover Dipstick
Chrome, Unplated, Zinc

SP7446

Mopar 273-340, 1964-1973
4-QT Front to Center Sump Steel
Oil Pan, Timing Cover Dipstick
Chrome, Zinc

SP7477

Mopar Early Hemi 331-392, 1951-1958
5-QT Rear Sump Steel Oil Pan,
Unplated

**SP7477****SP7447**

Mopar 360, 1971-1980
4-QT Front to Center Sump Steel
Oil Pan, Timing Cover Dipstick
Chrome, Zinc

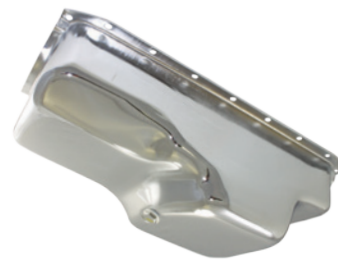
**SP7447****SP7456**

Mopar 361-440, 1956-1978
5-QT Front to Center Sump
Steel Oil Pan
Chrome, Unplated

**SP7456****SP7459**

Mopar 361-440, 1958-1978
7-QT Front to Center Sump
Steel Oil Pan
Zinc

**SP7459****SP7458**

Mopar 361-440, 1958-1978
7-QT Front to Center Sump
Steel Oil Pan
Unplated

**SP7458****SP7453**

Oldsmobile 330-455, 1964-1976
4-QT Rear Sump Steel Oil Pan,
Chrome, Unplated, Zinc

**SP7453****SP7455**

Pontiac 265-455, 1959-1981
4-QT Rear Sump Steel Oil Pan,
Chrome, Unplated, Zinc

**SP7455****OIL PAN PICK-UPS****SP7420**

Chevy SB Hi-Volume Oil Pan Pick-Up
**Will fit 7430, 7435, 7471, 7480X Oil Pan*

**SP7420****SP7414**

Chevy BB, 1965-1976 Standard Volume
Oil Pan Pick-Up
**Will fit 7432, 7437 Oil Pan*

**SP7414****SP7422**

Chevy BB, 1965-1976 Hi-Volume Oil Pan
Pick-Up
**Will fit 7432, 7437 Oil Pan*

**SP7422**



SP7427



SP7421

SP7427

Ford SB Double Sump Oil Pan Pick-Up
**Not for Trucks or Vans (302) 5.0L*
**Will fit 7457 Oil Pan*

SP7421

Ford SB, 1962-1995 Oil Pan Pick-Up
**Will fit 7474 Oil Pan*



SP7412



SP7411

SP7412

Mopar Hemi Stock 426 1/2" - 14" Threads,
 1966-Up Extra Capacity Oil Pan Pick-Up
**Will fit 7458 Oil Pan*

SP7411

Mopar B & RB 3/8" - 18" Threads,
 1966-Up Extra Capacity Oil Pan Pick-Up
**Will fit 7458 Oil Pan*



SP7423

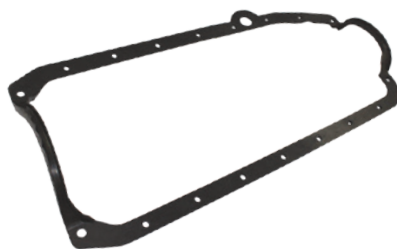

SP6105

SP7423

Mopar B & RB 3/8" - 18" Threads,
 1966-Up Oil Pan Pick-Up
**Will fit 7459 Oil Pan*

OIL PAN GASKETS

SP6105

Chevy SB 283-350, 1957-1979
 Rubber Gasket (2-Piece Rear Main Seal)
 Black
**Only for Steel Oil Pan*

SP6106

Chevy SB 305-350, 1980-1985
 Rubber Gasket (2-Piece Rear Main Seal)
 Black
**Only for Steel Oil Pan*



SP6106

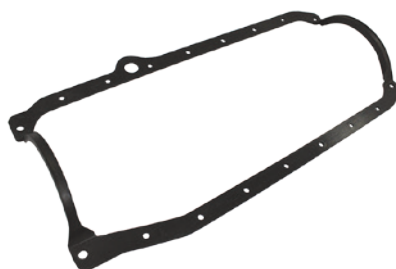

SP6107

SP6107

Chevy SB 305-350, 1986-1993
 Rubber Gasket (1-Piece Rear Main Seal)
 Black
**Only for Steel Oil Pan*

TRANSMISSION OIL PANS



SP8491

**Gasket & Drain Plug Included*



SP8593

**Gasket & Drain Plug Included*

SP8491

GM TH350 Finned Aluminum
 Transmission Oil Pan
 Black, Polished

SP8593

GM TH400 Finned Aluminum
 Transmission Oil Pan
 Black, Polished

SP8594
 GM 700R4 Finned Aluminum
 Transmission Oil Pan
 Black, Polished



**Gasket & Drain Plug Included*

SP8594

**TRANSMISSION
 OIL PAN GASKETS**

SP7680
 GM TH350 Transmission Oil Pan
 Cork, Gasket

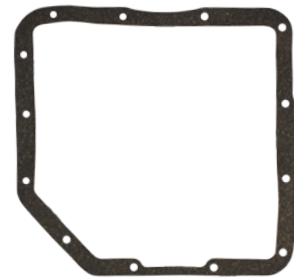

SP7680

SP7681
 GM TH400 Transmission Oil Pan
 Cork, Gasket



SP7681

SP7686
 GM 700R4 Transmission Oil Pan
 Cork, Gasket

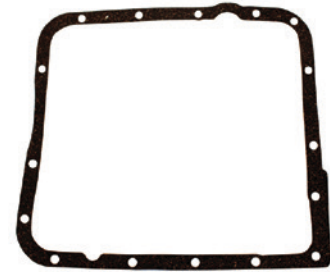

SP7686

MIRRORS

SP8223
 4" Stainless Steel Outside Mirror
 Swan Neck Style, Stud Mount
 2-Piece (Pair)



SP8223

SP8217
 4" Stainless Steel Outside Mirror
 Peep Style, 1-Piece (Single)
**Fits Driver & Passenger Side*



SP8217

SP8215
 9-3/4" Stainless Steel Universal Interior
 Rear View Mirror with Day/Night Switch
 1-Piece (Single)



SP8215

SP8218
 5-1/2" Aluminum Ball-Milled Universal
 Interior Rear View Mirror
 1-Piece (Single)



SP8218

SP8219
 8-1/4" Aluminum Ball-Milled Universal
 Interior Rear View Mirror
 1-Piece (Single)



SP8219

**WINDOW & DOOR
 HANDLES**

SP8236
 3" Chrome Aluminum Universal
 Window Handles



SP8236



SP8235



SP8228



SP8227



SP8425



SP8426



SP8427



SP8428



SP8210



SP8211



SP8234

SP8235
3" Chrome Aluminum Universal
Door Handles

SP8228
4-1/4" Chrome Aluminum Universal
Window Handles

SP8227
4-1/4" Chrome Aluminum Universal
Door Handles

POLISHED ALUMINUM KNOBS

SP8425
Polished Aluminum Milled Dash Knob
1/8" Hole

SP8426
Polished Aluminum Milled Gear Shift
Knob with 5/16", 1/4" & 3/8" Inserts

SP8427
Polished Aluminum Steering Column
Shifter, GM 1967-1994

SP8428
Polished Aluminum Steering Column
Dress-Up Kit, GM Cars & Trucks

GAS & BRAKE PEDALS

SP8210
Polished Aluminum Street Rod Firewall
Mount Pedal

SP8211
Polished Aluminum Street Rod Firewall
Mount Pedal

SP8234
Polished Aluminum Street Rod Floor
Mount Pedal

SP7210

Chrome Steel Spoon Style Firewall Mount Pedal



SP7210



SP8226

SP8226

Polished Aluminum Firewall Mount Oval Universal Pedal

SP8220

Chrome Alloy Barefoot Pedal

SP8208

Polished Aluminum Gas Pedal



SP8220

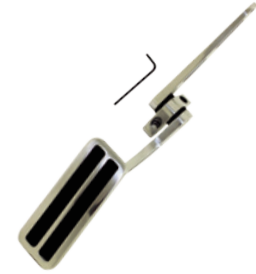

SP8208

SP8212

Polished Aluminum Street Rod Brake Pedal, 3-1/8" x 2" Manual Transmission

SP8213

Polished Aluminum Street Rod Brake Pedal, 4-1/4" x 2-1/2"



SP8212



SP8213

SP8214

Polished Aluminum Dimmer Pedal

SP8221

Chrome Alloy Barefoot Dimmer Pedal



SP8214



SP8221

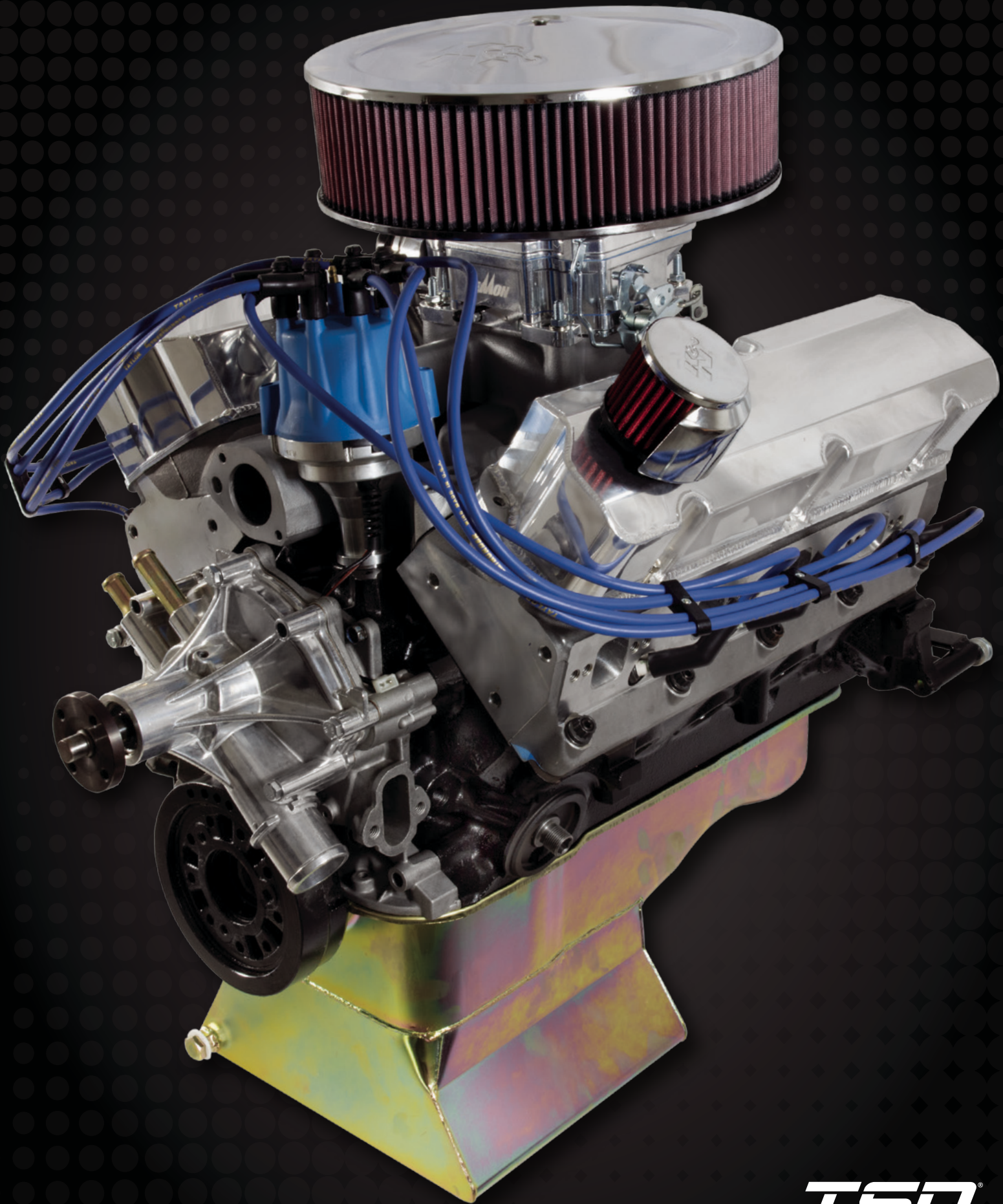

ELECTRIC FUEL PUMP & FILTER MOUNTING BRACKET KIT



JM1040-KT

- Universal In-Line Fuel Pump, In-line Fuel Filter, AN Cross Over Tube, and Dual Pump/Filter Mounting Bracket
- Quick disconnect/ AN /hose barb fittings, and power connection hardware



JM1041-KT

- Universal In-Line Fuel Pump, In-line Fuel Filter, and Pump/Filter Mounting Bracket
- Quick disconnect/ AN /hose barb fittings, and power connection hardware

TSP's Fuel Pump and Filter Mounting Kit was designed for the popular Bosch 044 style electric fuel pump and accompanying fuel filter. Available in black and red, this aluminum bracket offers a clean look and easy installation.



**Fittings Included*

JM1040



81097

JM1040

Universal Electric EFI Bosch 044 Style Inline Fuel Pump, 85 GPH, -10AN Inlet, -6AN Outlet, Up to 800HP
Black

81097

Male Push on EFI Fitting, -8AN

81098

Quick Disconnect Female EFI Adapter Fitting, -8AN

JM1019

EFI Inline Bosch 044 Style Fuel Pump Aluminum Mounting Bracket
Black, Red



JM1020

EFI Inline Bosch 044 Style Fuel Pump and Fuel Filter Aluminum Mounting Bracket
Black, Red

JM1021

Aluminum Inline Fuel Filter with 10 Micron Element, -10 AN Inlet/Outlet Size
Black, Red

JM1022

Aluminum Inline Fuel Filter with 40 Micron Element, -10 AN Inlet/Outlet Size
Black, Red

JM1023

Aluminum Inline Fuel Filter with 100 Micron Element, -10 AN Inlet/Outlet Size
Black, Red

JM1024

10 Micron Paper Fuel Filter Element

JM1025

40 Micron Stainless Steel Fuel Filter Element



81098

JM1019



JM1020



JM1021



JM1022



JM1023



JM1024



JM1025

JM1026

100 Micron Stainless Steel Fuel Filter Element



JM1026

JM1027

Aluminum Inline Fuel Filter Mounting Bracket
Black, Red



JM1027



JM1059

Billet Aluminum EFI Fuel Pressure Bypass Regulator, 40-75 PSI,
-6 AN Inlet/Outlet Size
Black, Red



JM1059



FUEL FILTER REGULATOR

TSP's new fuel filter regulator is a great way to get fuel to your engine swap. This Corvette-style filter has a built-in regulator, and its bypass design can run one inlet with two outlets – one to the engine and a return outlet to the tank.



81095-2KT
 LS Fuel Filter Pressure Regulator, 58 PSI,
 Inline Fuel Pump 85 GPH Bosch 044 Style,
 -8AN Fittings, Hose Kit



81095



81095-KT



81095-1KT

FUEL FILTER REGULATOR

81095
 LS Fuel Filter Pressure Regulator, 58 PSI

81095-KT
 LS Fuel Filter Pressure Regulator, 58 PSI,
 -6AN Fittings

81095-1KT
 LS Fuel Filter Pressure Regulator, 58 PSI,
 -6AN Fittings, Hose Kit

81095-2KT
 LS Fuel Filter Pressure Regulator, 58 PSI,
 Inline Fuel Pump 85 GPH Bosch 044 Style,
 -8AN Fittings, Hose Kit

ELECTRIC FUEL PUMPS, FUEL REGULATORS AND MICRO ELECTRIC FUEL PUMPS



JM1044
Electric Carburetor Fuel Pump, 155 GPH

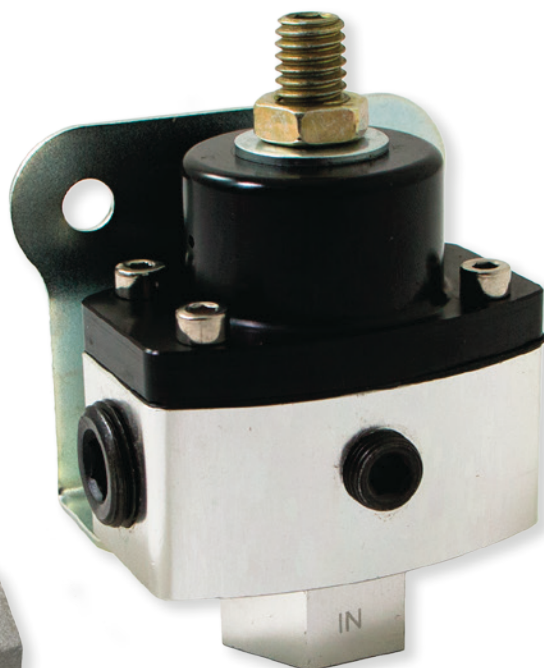

JM1057
Billet Aluminum Fuel Pressure Regulator
5-12 PSI, 3/8" NPT

TSP's Electric Fuel Pumps and Regulators offer reliable performance for anyone who is looking for more than a mechanical pump can offer. Cast from lightweight aluminum, our electric fuel pumps contain high-quality components and low-amp-draw electric motors. Our fuel pressure regulators, which also feature an aluminum body, allow you to fine-tune how much fuel gets to your fuel injection system or carburetor.



JM1042



JM1043

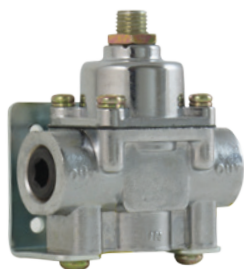

JM1055



JM1056



JM1031



JM1032



JM1033



JM1034



JM1035

ELECTRIC FUEL PUMPS

JM1042

Electric Carburetor Fuel Pump, 115 GPH,
3/8" NPT Inlet/Outlet Port
Chrome

JM1043

Electric Carburetor Fuel Pump, 130 GPH,
3/8" NPT Inlet/Outlet Port
Chrome

JM1044

Electric Carburetor Fuel Pump, 155 GPH,
3/8" NPT Inlet/Outlet Port
Chrome

FUEL REGULATORS

JM1055

Aluminum Fuel Pressure Regulator,
1-4 PSI, 3/8" NPT
Black, Chrome

JM1056

Aluminum Fuel Pressure Regulator,
5-9 PSI, 3/8" NPT
Black, Chrome

JM1057

Billet Aluminum Fuel Pressure Regulator,
5-12 PSI, 3/8" NPT
Black, Blue, Clear Anodized, Red

MICRO ELECTRIC FUEL PUMPS

JM1031

Micro Electric Fuel Pump with Filter,
28 GPH, 2-3.5 PSI,
Gasoline - For Carburetor

JM1032

Micro Electric Fuel Pump with Filter,
35 GPH, 4-7 PSI, Gasoline - For Carburetor

JM1033

Micro Electric Fuel Pump with Filter,
35 GPH, 4-7 PSI, Diesel

MICRO ELECTRIC FUEL PUMP FILTERS

JM1034

40 Micron Micro Electric Fuel Pump Filter
for Gasoline
Fits JM1031/JM1032

JM1035

100 Micron Micro Electric Fuel Pump Filter
for Diesel
Fits JM1033

MECHANICAL FUEL PUMPS



Chrome finish



Adjustable plate for different positioning



Heavy-duty rubber seals



JM1037

Chevy SB V8 Engine Super Flow 6 Valve
Racing Mechanical Fuel Pump

TSP's Mechanical Fuel Pumps are for those who want to upgrade their fuel pump without losing that classic look. Our pumps are cast from lightweight aluminum and given a beautiful, high-quality chrome finish. They've been designed to flow at an improved rate over stock. All of our pumps feature an adjustable rotating plate for a custom-fit to your engine bay and have been given heavy duty rubber seals for optimum leak protection.



JM1003



JM1004



JM1005



JM1006



JM1007



JM1008



JM1009



JM1010



JM1011



JM1012



MECHANICAL FUEL PUMPS

2 VALVE: 80 GPH

JM1003

Chevy SB 262-400 Mechanical Fuel Pump, 6 PSI, 1/4" NPT Inlet/Outlet
Black, Chrome

JM1004

Chevy BB 396-454 Mechanical Fuel Pump, 6 PSI, 1/4" NPT Inlet/Outlet
Black, Chrome

JM1005

Chrysler SB 273-360 Mechanical Fuel Pump, 6 PSI, 1/4" NPT Inlet/Outlet
Black, Chrome

JM1006

Chrysler BB 361-440 Mechanical Fuel Pump, 6 PSI, 1/4" NPT Inlet/Outlet
Black, Chrome

JM1007

Ford SB 221-351 Windsor Mechanical Fuel Pump, 6 PSI, 1/4" NPT Inlet/Outlet
Black, Chrome

JM1008

Ford FE 352-428 Mechanical Fuel Pump, 6 PSI, 1/4" NPT Inlet/Outlet
Black, Chrome

JM1009

Ford 351 Cleveland Mechanical Fuel Pump, 6 PSI, 1/4" NPT Inlet/Outlet
Black, Chrome

JM1010

Ford BB 429/460 Mechanical Fuel Pump, 6 PSI, 1/4" NPT Inlet/Outlet
Black, Chrome

JM1011

Oldsmobile 215-455 Mechanical Fuel Pump, 6 PSI, 1/4" NPT Inlet/Outlet
Black, Chrome

JM1012

Pontiac 301-455 Mechanical Fuel Pump, 6 PSI, 1/4" NPT Inlet/Outlet
Black, Chrome

6 VALVE: 110 GPH

JM1015

Chevy SB 262-400 Racing Mechanical Fuel Pump, 7.5 PSI, 3/8" NPT Inlet/Outlet
Black, Chrome



JM1015



JM1016



6 VALVE: 130+ GPH

JM1037

Chevy SB High-Flow Racing Mechanical Fuel Pump, 12-16 PSI, 1/2" NPT Inlet/Outlet
Black, Chrome



JM1037



JM1066

FITTINGS

JM1066

Mechanical Fuel Pump Brass Fitting Kit

MECHANICAL FUEL PUMP BLOCK-OFF/ MOUNTING PLATES

SP7605

Chevy SB Mechanical Fuel Pump Block-Off Plate with Gasket
Chrome Steel, Unplated Steel

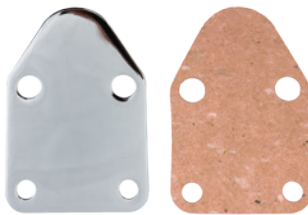

SP7605

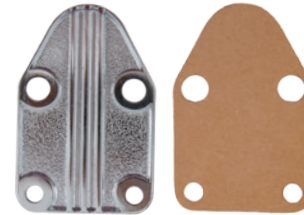

SP8511

SP8511

Chevy SB Mechanical Fuel Pump Block-Off Plate with Gasket
Die Cast Aluminum

SP7623

Chevy SB Mechanical Fuel Pump Mounting Plate with Gasket
Chrome Steel



SP7623

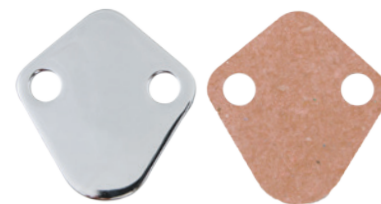

SP7604

SP7604

Chevy BB Mechanical Fuel Pump Block-Off Plate with Gasket
Chrome Steel, Unplated Steel

FUEL PRESSURE GAUGES

JM1017

0-15 PSI Liquid Filled Fuel Pressure Gauge, 1/8" NPT, 1.5" Diameter
Black, Chrome



JM1017



JM1018





JM3101

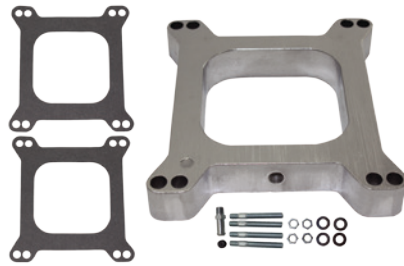

SP9131

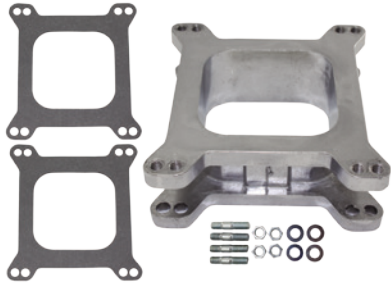

SP9132

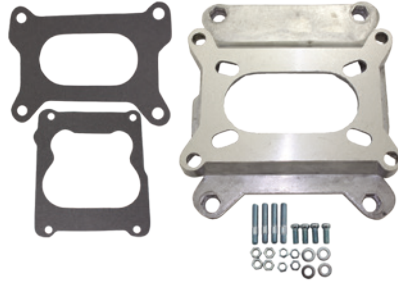

SP9144

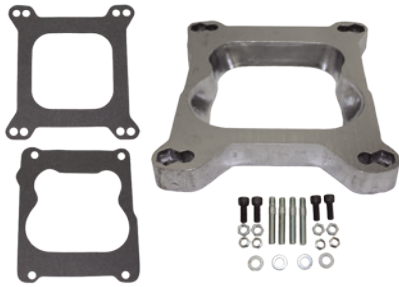

SP9130

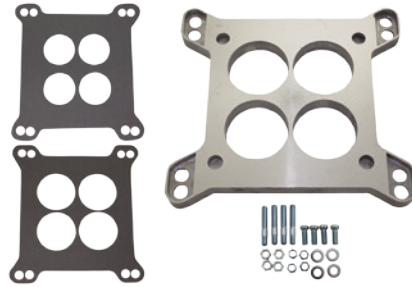

SP9140

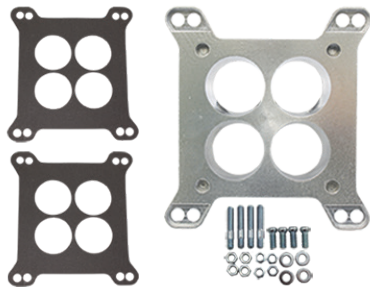

SP9148

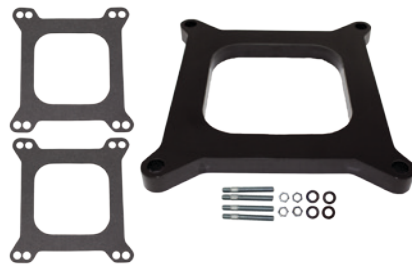

SP9138



SP9136



SP9137

THROTTLE CABLE BRACKET

JM3101

Aluminum Throttle Cable Bracket Kit for Holley 4150/4160 Style Carburetors
Black, Blue, Chrome, Red

ALUMINUM CARB SPACERS & ADAPTERS

SP9131

Holley/AFB 4BBL Spacer Kit
3/8" Vac-Tube Included, 1" Open Port

SP9132

Holley/AFB 4BBL Spacer Kit,
2" Open Port

SP9144

Holley/Rochester 2BBL to any Q-Jet Spread Bore Manifold Adapter Kit,
1-1/8" Open Port

SP9130

Holley to Q-Jet Adapter Kit, 3/4" Tapered Open Port

SP9140

4BBL Universal Adapter Kit, 1/2" Ported

SP9148

Holley/AFB 4BBL Adapter to Smaller Manifold Kit, 1/2" Tapered Port

PHENOLIC CARB SPACERS

SP9138

Holley/AFB 4BBL Spacer Kit,
1/2" Open Port

SP9136

Holley/AFB 4BBL Spacer Kit,
1" Open Port

SP9137

Holley/AFB 4BBL Spacer Kit,
2" Open Port

**TSP has no affiliation with Holley or its subsidiaries.*

SP9134
Holley/AFB 4BBL Spacer Kit,
1" Ported



SP9134

SP9135
Holley/AFB 4BBL Spacer Kit,
2" Ported



SP9135

THROTTLE, KICK-DOWN & CHOKE CABLES

SP7207
24" Black Plastic Throttle Cable Universal
Applications



SP7207

SP7208
24" Braided Stainless Steel Throttle
Cable for Carbureted Applications
**Also works with Ford EFI, 1986-1993*



SP7208

SP7209
36" Braided Stainless Steel Throttle
Cable for Carbureted Applications
**Also works with Ford EFI, 1986-1993*



SP7209

SP6049
GM/Chevy TH350 Braided Stainless
Steel Kick-Down Cable

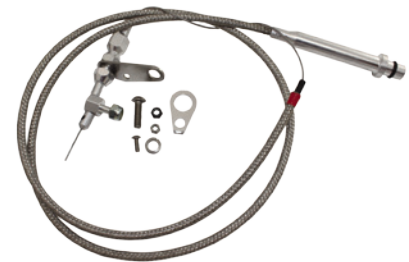

SP6049

SP6050
GM/Chevy 700R4 Braided Stainless
Steel Kick-Down Cable

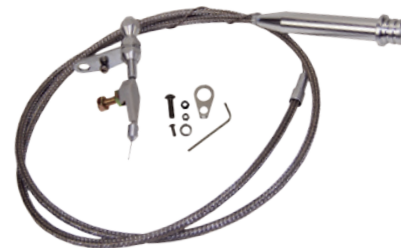

SP6050

SP6048
6 FT. Braided Stainless Steel
Choke Cable
**Recommended Mount Hole
3/8" Diameter*

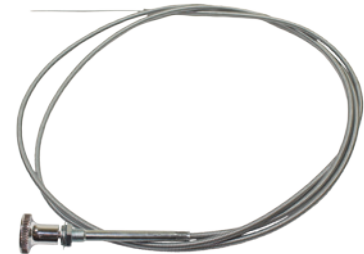

SP6048

FUEL LINES

SP9279
Chrome Steel Fuel Line
Fits Holley Carb 3310 8-21/32" Centers



SP9279

SP9278
Chrome Steel Fuel Line
Fits Holley Quad 9-5/16" Centers



SP9278

**TSP has no affiliation with Holley or its subsidiaries.*



SP9281



SP9282

SP9281

Chrome Steel Fuel Line
Fits Edelbrock/Carter Carbs
3/8" NPT Inlet

SP9282

Chrome Steel Fuel Line
Fits Holley Carbs Barb Hose Fitting
3/8" NPT Inlet



JM3110



JM3111

FUEL LOGS

JM3110

Billet Aluminum Adjustable Telescopic
Fuel Log for 4150/4500 Holley Style Carbs

JM3111

Billet Aluminum Adjustable Pivoting
Telescopic Fuel Log for 4150/4500
Holley Style Carbs

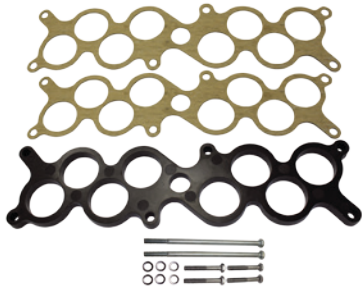

SP8436



SP8438

**PHENOLIC MANIFOLD
HEAT SPACERS**

SP8436

Ford GT40 1/2" Thick Phenolic Manifold
Heat Spacer

SP8438

Ford GT40 1" Thick Phenolic Manifold Heat
Spacer

SP8437

Ford Stock EFI 5.0L 1/2" Thick Phenolic
Manifold Heat Spacer

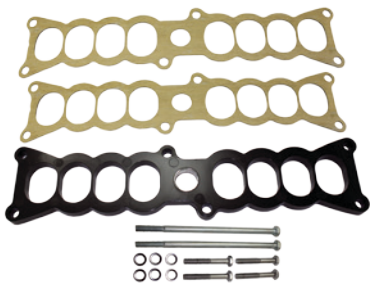

SP8437



SP6134

**MANIFOLD HEAT
SPACER GASKETS**

SP6134

Ford GT40 Manifold Heat Spacer Gasket

SP6133

Ford Stock EFI 5.0L Manifold Heat
Spacer Gasket



SP6133

**TSP has no affiliation with Holley or its subsidiaries.*

STEERING



Billet aluminum cap



TIG Welded

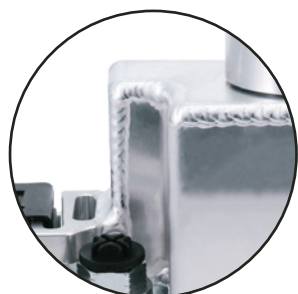

6061-T6 Aluminum construction

**JM2021C**

GM Type II Power Steering Pump With
Aluminum Fabricated Reservoir

**Assembly Required*

TSP's Steering Pumps and Boxes are built with high-quality materials to ensure performance and reliability. We have the most popular types to fit many applications, and our chrome pumps will greatly improve the look of any engine.



JM2000



JM2003



JM2010



JM2011



JM2013



JM2014



JM2012



JM2001



JM2004



JM2002



POWER STEERING PUMPS

JM2000

GM Saginaw Power Steering Pump with Billet Aluminum Cap & Dipstick, Keyway Style, Fits 1955-1972
Black, Chrome

**Black finish w/ plastic cap*

JM2003

GM Early Saginaw Power Steering Pump with Billet Aluminum Cap & Dipstick, Keyway Style
Chrome

JM2010

GM Type II Power Steering Pump
-10AN Inlet, -6AN Outlet
Black, Chrome, Satin

JM2011

GM Type II Power Steering Pump with Black Plastic Reservoir -6AN Outlet
Black, Chrome, Satin

JM2021

GM Type II Power Steering Pump With Aluminum Fabricated Reservoir
Black, Chrome

**Chrome finish w/ clear anodized reservoir*

JM2013

GM Type II Power Steering Pump Hardline, Low Mount
Black, Chrome

JM2014

GM Type II Power Steering Pump Hardline, Mid Mount
Black, Chrome

POWER STEERING PUMP RESERVOIR

JM2012

Power Steering Reservoir
Black, Polished

POWER STEERING PUMP CANS

JM2001

GM Saginaw Power Steering Pump
Steel Can
Chrome

JM2004

GM Early Saginaw Power Steering Pump
Steel Can
Chrome

POWER STEERING PUMP CAP

JM2002

Billet Aluminum Cap with Dipstick for Saginaw Power Steering Pump
Chrome

CYLINDER HEADS

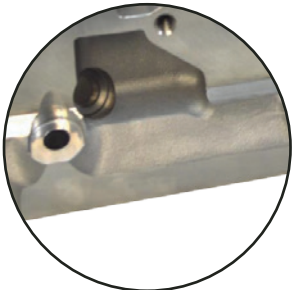

Lightweight aluminum



CNC'd ports and combustion chambers

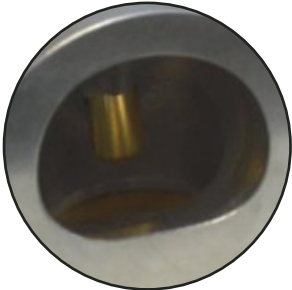

Improved runner design

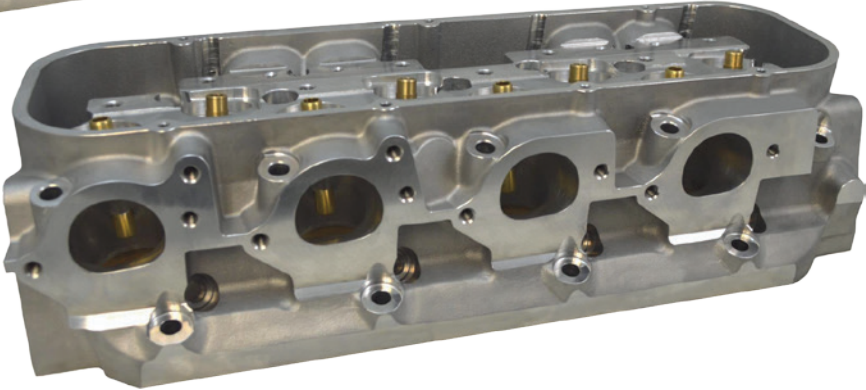
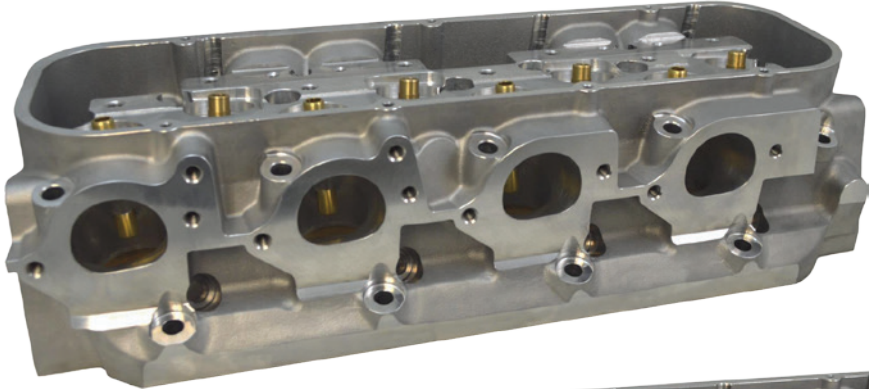

JM4200
Chevy BB Aluminum Cylinder Heads, 345cc Rectangle Intake Port Runners, 124cc Combustion Chamber

TSP's high-performance cylinder heads are cast from high-quality aluminum and designed for optimal air flow. The combustion chambers, intake ports, and exhaust ports are all fully CNC-ported for maximum horsepower and torque. With several variations for multiple engine types, TSP's aluminum cylinder heads are the perfect way to cap your performance powerplant.

**JM4100****JM4100S****JM4300****JM4500****JM4600**

CYLINDER HEADS

JM4100

Chevy SB Aluminum Cylinder Heads,
198cc Intake Ports,
64cc Combustion Chamber

JM4100S

Chevy SB Aluminum Cylinder Heads,
Straight Spark Plugs, 198cc Intake Ports,
64cc Combustion Chamber

JM4200

Chevy BB Aluminum Cylinder Heads,
345cc Rectangle Intake Port Runners,
124cc Combustion Chamber

JM4300

Ford SB Aluminum Cylinder Heads,
185cc Intake Runners,
60cc Combustion Chamber

JM4500

Chevy LS6 Aluminum Cylinder Heads,
210cc Intake Runners,
64cc Combustion Chamber

JM4600

Chevy LS3 Aluminum Cylinder Heads,
260cc Intake Runners,
68.4cc Combustion Chamber

'32 FORD REAR-END KIT

Fully adjustable 1" diameter by 0.156" wall tubing with 3/4" rod ends and nylon bushings.

CB5101

Ford Triangulated 4-Link Rear-End Suspension Kit (Plain Steel)

- Ford models (1932)

CB5102

Ford Triangulated 4-Link Rear-End Suspension Kit (Stainless Steel)

- Ford models (1932)

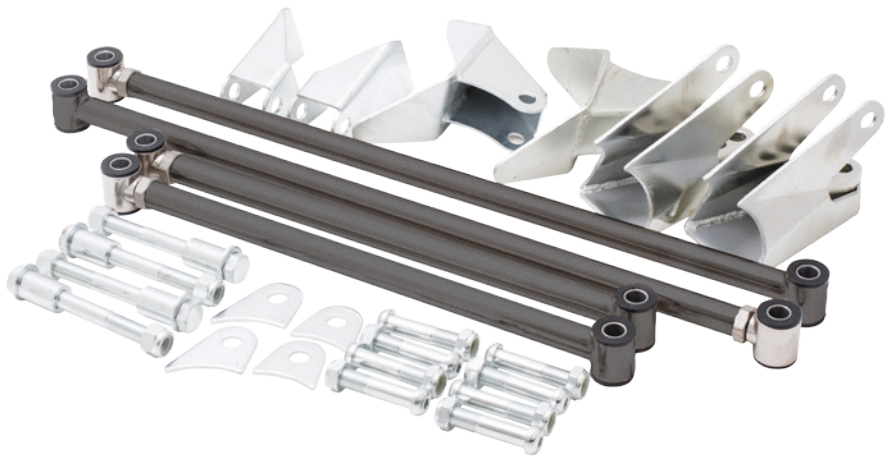

CB5101

'32 FORD GRILL SHELL

AC1001 (Without Crank Hole)

1932 Ford Steel Grill Shell without Crank Hole, Smooth on Top Black

- Ford models (1932)
- High quality steel
- Primed and ready for paint
- Exact reproduction of original

AC1002 (With Crank Hole)

1932 Ford Steel Grill Shell with Crank Hole, Hole on Top Black

- Ford models (1932)
- High quality steel
- Primed and ready for paint
- Exact reproduction of original

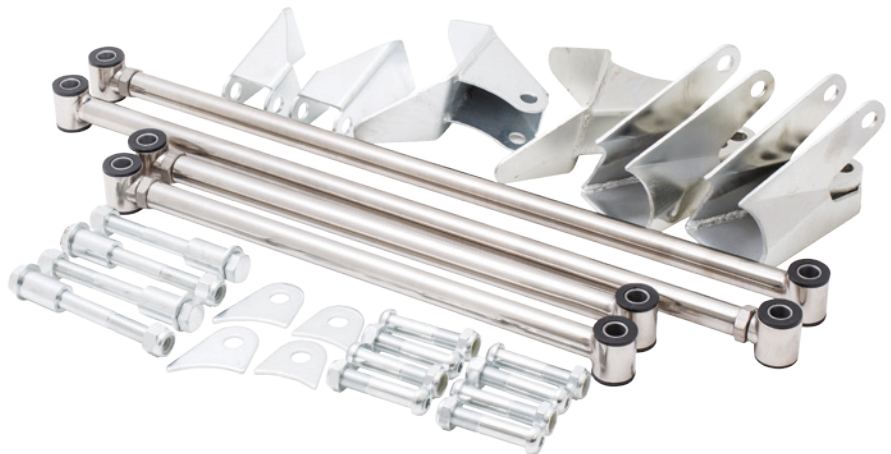

CB5102



AC1001



AC1002



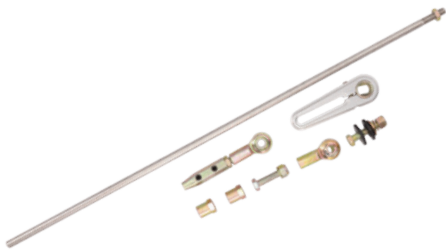

CB5010



CB5011



CB8001

CB5010
Chevy Column Shift Linkage

CB5011
Ford Column Shift Linkage for C4 & C6
Transmission

CB8001
Brake Booster Electric Vacuum Pump Kit
for Brake Systems 18" to 22", 12V

BLACK < **SERIES**



JM7701-2ABK



JM7702ABK



JM7706ABK



JM7710ABK



JM6501ABK



JM6502ABK



JM6506ABK



JM6510ABK



ES1001BK



ES1004BK

BLACK SERIES

JM7701-2ABK (Fixed Collar)

Chevy SB/BB V8 Engine Pro Series
Ready to Run Distributor, Fixed Collar

JM7702ABK

Ford SB 289/302 V8 Engine
Pro Series Ready to Run Distributor

JM7706ABK

Ford 351 Cleveland/Ford BB 429-460
V8 Engine Pro Series Ready to Run
Distributor

JM7710ABK

Ford 351 Windsor V8 Engine
Pro Series Ready to Run Distributor

JM6501ABK

Chevy SB/BB V8 Engine, 65K Volt Coil
HEI Distributor, OEM Cap

JM6502ABK

Ford SB 289/302 V8 Engine,
65K Volt Coil HEI Distributor

JM6506ABK

Ford 351 Cleveland/Ford BB 429-460
V8 Engine, 65K Volt Coil HEI Distributor

JM6510ABK

Ford 351 Windsor V8 Engine,
65K Volt Coil HEI Distributor

ES1001BK

GM 10SI Alternator, 110 AMP, V-Belt,
1 or OEM Wire Setup, Fits 1968-1982

ES1004BK

GM Mini Denso Style Alternator,
Street Rod Race, 90 AMP, V-Belt,
1-Wire Setup

ES1006BK

GM CS130 Alternator with Side Battery Post, 160 AMP, Serpentine Belt, 1 or OEM Wire Setup, Fits 1968-1995

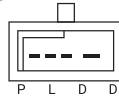

ES1006BK

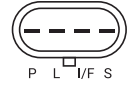

ES1024BK

ES1024BK

LS Truck AD244 Alternator, 220 AMP, Serpentine Belt, 4 Pin Connector

ES1025BK

LS Car CS130D Alternator, 180 AMP, Serpentine Belt, 4 Pin Connector

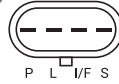

ES1025BK

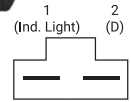

ES1031BK

ES1031BK

Ford 1G Alternator, 110 AMP, V-Belt, 1 or OEM Wire Setup, Fits 1963-1986

JM7007ABK

Chevy SB/BB 1.9HP Starter, Staggered Mount, Denso Style, 168 Tooth Flywheel



JM7007ABK

JM7008ABK

Oldsmobile/Pontiac 1.9HP Starter, Denso Style
- Will not fit 301



JM7008ABK

JM7009ABK

LS 1.9HP Starter, Denso Style



JM7009ABK

JM7013ABK

Mopar SB/BB/Hemi 1966-1987 1.9HP Starter with Nose, Denso Style



JM7013ABK

HC5001BK

Sanden 508 R134A Style A/C Compressor V-Belt



HC5001BK

HC5002BK

Sanden 508 R134A Style A/C Compressor Serpentine Belt



HC5002BK



HC5005BK



HC8011BK

HC8012BK

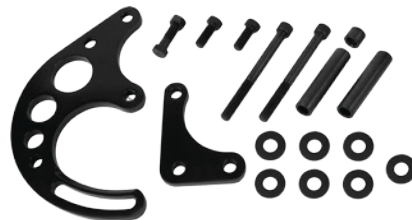

HC8021BK

HC8022BK

HC8049BK

JM9101BK

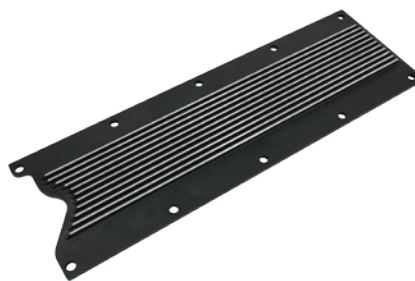
JM9105-1BK

JM9106BK

81045BK
HC5005BK

Sanden SD-7 Style A/C Compressor
Serpentine Belt, 6 Groove

HC8011BK

Chevy SB Aluminum Mechanical
Water Pump, Short Style

HC8012BK

Chevy SB Aluminum Mechanical
Water Pump, Long Style

HC8021BK

Chevy BB Aluminum Mechanical
Water Pump, Short Style

HC8022BK

Chevy BB Aluminum Mechanical
Water Pump, Long Style

HC8049BK

Aluminum Mechanical Water Pump,
Passenger Side Inlet

JM9101BK

Chevy SB Long Water Pump,
Passenger Side, Aluminum Alternator
Bracket Kit

JM9105-1BK (New Design)

Chevy SB Long Water Pump, Aluminum
Power Steering Pump Bracket Kit

JM9106BK

Chevy SB Long Water Pump, Driver Side,
Aluminum A/C Compressor Bracket Kit

81045BK

LS1/LS2/LS6 Valley Cover

JM2010BK

GM Type II Power Steering Pump
-8AN Inlet, -6AN Outlet



JM2010BK



JM1020BK

JM1020BK

EFI Inline Bosch 044 Style Dual
Fuel Pump and Fuel Filter Aluminum
Mounting Bracket

JM1040BK

Universal Electric EFI Inline Fuel Pump
350 LPH Bosch 044 Style,
-10AN Inlet, -6AN Outlet Up to 800HP



**Fittings Included*

JM1040BK



JM1003BK

JM1003BK

Chevy SB 262-400 Mechanical
Fuel Pump, V8 Engine, 6 PSI
1/4" NPT Inlet/Outlet

JM1004BK

Chevy BB 396-454 Mechanical
Fuel Pump, V8 Engine, 6 PSI
1/4" NPT Inlet/Outlet

JM1007BK

Ford SB 221-351 Windsor Mechanical
Fuel Pump, V8 Engine, 6 PSI
1/4" NPT Inlet/Outlet



JM1004BK



JM1007BK

JM1037BK

Chevy SB Super Flow Racing Mechanical
Fuel Pump, V8 Engine,
12-16 PSI 1/2" NPT Inlet/Outlet

SP6490BK

Oval Half Finned Aluminum
Air Cleaner with Paper Kit,
12" x 8-3/8" Size, 3-3/8" Height



JM1037BK



SP6490BK

SP6491BK

Oval Half Finned Aluminum
Air Cleaner with Paper Kit,
15" x 8-3/8" Size, 3-3/8" Height



SP6491BK



SP6498BK

SP6498BK

Oval Full Finned Aluminum Air Cleaner
with Paper Kit, 12" x 8-3/8" Size,
3-3/8" Height



SP8442BK



SP8450BK



SP8458BK



SP8486BK



SP8487BK



SP8525BK



SP8526BK



SP8527BK



SP8528BK



SP8530BK

SP8442BK

Chevy SB 265-350, 1955-1979
4-QT Rear Sump Finned Aluminum
Oil Pan, Driver Side Dipstick

SP8450BK

Dual Finned Aluminum Hood Scoop,
Fits Single or Dual 4-Barrel Carb
Application with 5/1/8" Neck
19-1/2" Length, 10"Width, 5-1/2" Height

SP8458BK

Billet Aluminum Wire Loom Set,
9.5mm Finned

SP8486BK

Oval Finned Aluminum Push-in Breather

SP8487BK

Oval Finned Aluminum Push-in Breather
with PCV Valve

SP8525BK

1958-1986 Chevy SB 283-400
Short Finned Aluminum Valve Cover
with Hole, 3-1/2" Height

SP8526BK

1958-1986 Chevy SB 283-400
Tall Finned Aluminum Valve Cover
with Hole, 4" Height

SP8527BK

1987-1999 Chevy SB 5.0L-5.7L
Short Finned Aluminum Valve Cover
with Hole, 3-1/4" Height

SP8528BK

1987-1999 Chevy SB 5.0L-5.7L
Tall Finned Aluminum Valve Cover
with Hole, 4" Height

SP8530BK

1965-1995 Chevy BB 396-502
Tall Finned Aluminum Valve Cover
with Hole, 4-1/4" Height

SP8491BK

GM TH350 Finned Aluminum
Transmission Oil Pan



**Gasket & Drain Plug Included*

SP8491BK



**Gasket & Drain Plug Included*

SP8593BK

SP8594BK

GM 700R4 Finned Aluminum
Transmission Oil Pan

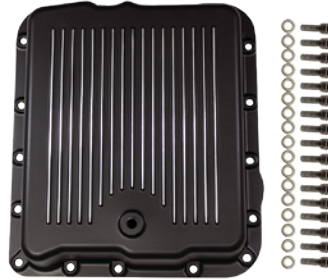

**Gasket & Drain Plug Included*

SP8594BK

SP8854BK

Chevy SB LWP Water Pump Pulley,
Single Groove



SP8854BK

SP8856BK

Chevy SB LWP Water Pump Pulley,
Double Groove



SP8856BK

SP8857BK

Chevy SB LWP Crankshaft Pulley,
Double Groove



SP8857BK

SP8859BK

Chevy SB LWP Crankshaft Pulley,
Triple Groove



SP8859BK

SP8848BK

Chevy SB/BB Power Steering Pulley,
Single Groove



SP8848BK

SP8850BK

Chevy SB SWP Water Pump Pulley,
Single Groove



SP8850BK

SP8852BK

Chevy SB SWP Water Pump Pulley,
Double Groove



SP8852BK



SP8851BK



SP8853BK



SP8858BK

SP8851BK

Chevy SB SWP Crankshaft Pulley,
Single Groove

SP8853BK

Chevy SB SWP Crankshaft Pulley,
Double Groove

SP8858BK

Chevy SB SWP Crankshaft Pulley,
Triple Groove

81300BK

Fender Covers



INSTRUCTION



S & DIAGRAMS

DISTRIBUTOR INSTALLATION & DIMENSION

PRO BILLET DISTRIBUTOR INSTALLATION

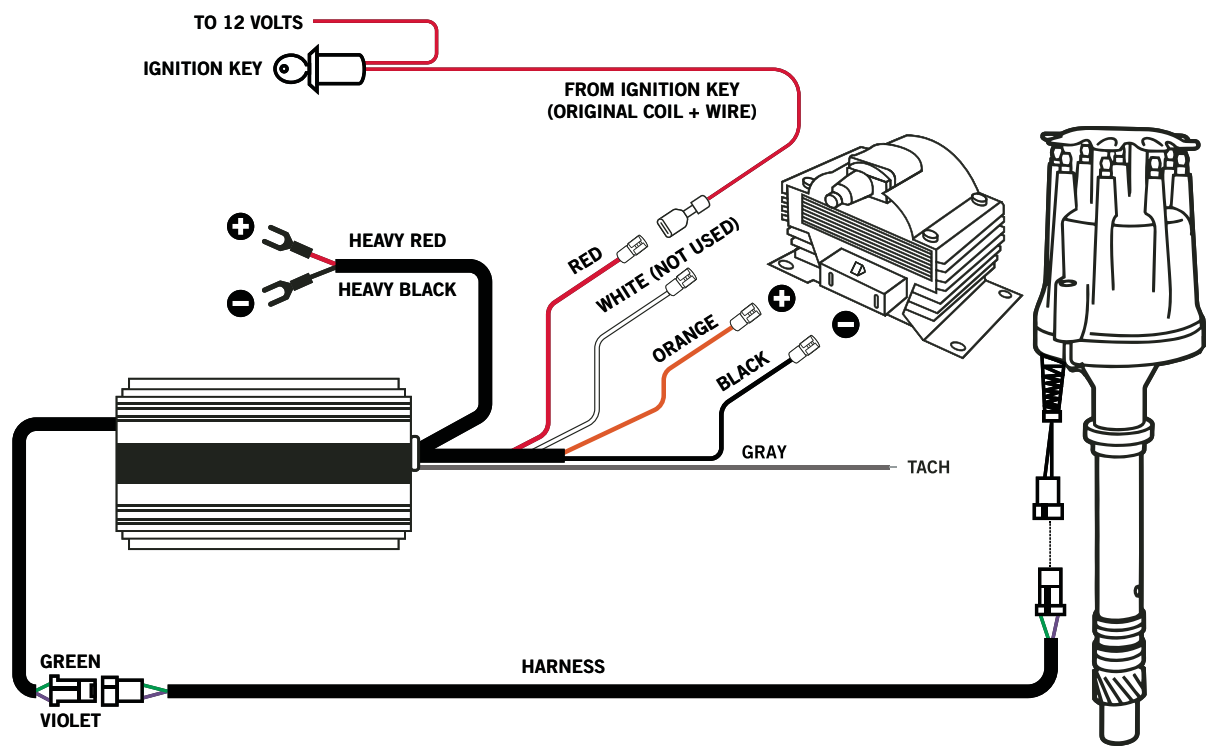

WARNING: This distributor is not compatible with stock points distributor coil, must use high output coil. Must bypass ballast resistor if applicable.

PRO SERIES READY TO RUN INSTALLATION

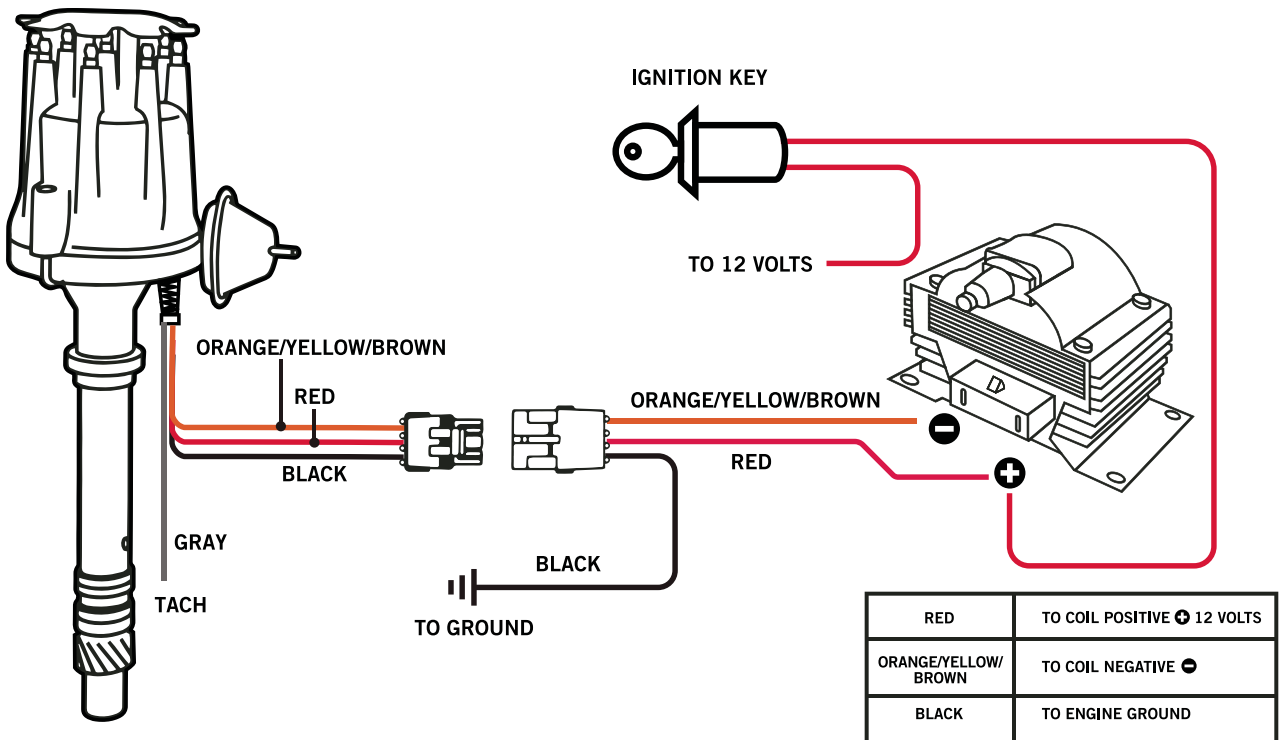

DISTRIBUTOR INSTALLATION & DIMENSION

READY TO RUN INSTALLATION

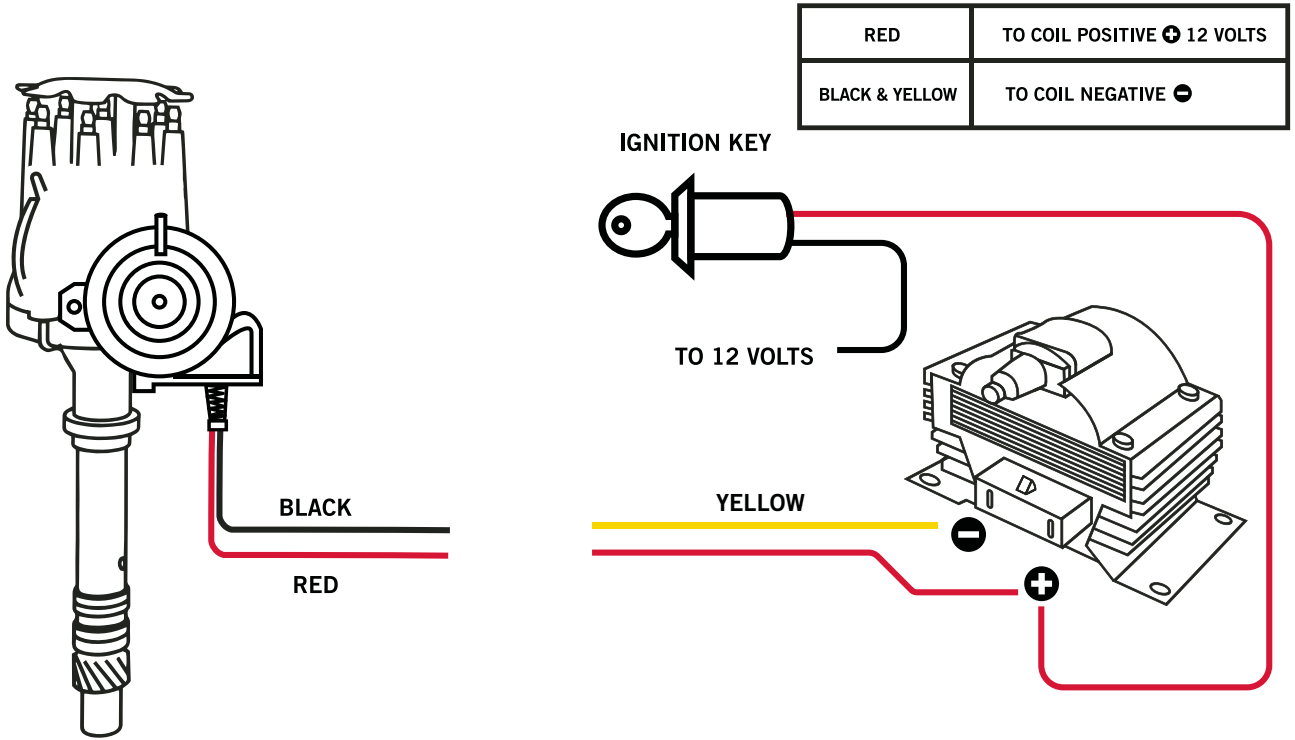

WARNING: This distributor is not compatible with stock points distributor coil, must use high output coil. Must bypass ballast resistor if applicable.

DISTRIBUTOR CAP DIMENSIONS

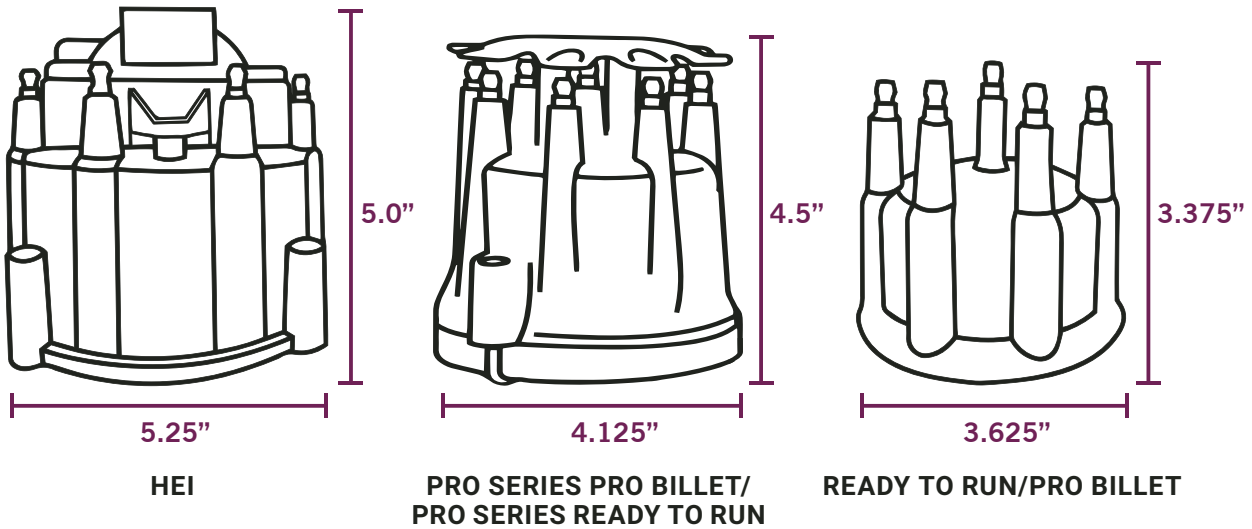

FAN DIMENSIONS

STANDARD UNIVERSAL FANS

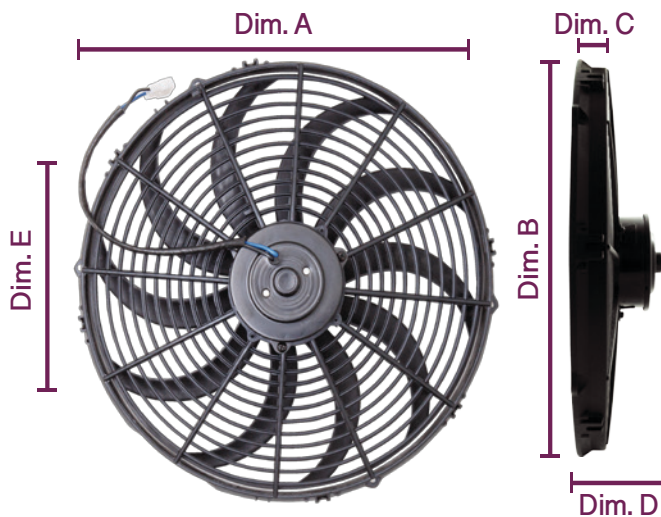

SIZE	PRODUCT NO.	DIM. A	DIM. B	DIM. C	DIM. D	DIM. E
8"	HC6101	8 1/8"	8"	1 1/4"	2 1/4"	4 3/8"
10"	HC6102	11 1/2"	10 3/4"	1 1/2"	2 3/8"	8 7/8"
12"	HC6103	13"	12 1/8"	1 1/2"	2 3/8"	6 3/16"
14"	HC6104	14 7/8"	14"	1 1/2"	3 1/8"	7 1/8"
16"	HC6105	16 1/2"	15 5/8"	1 1/8"	3 5/8"	14"

PRO SERIES S-BLADE FANS

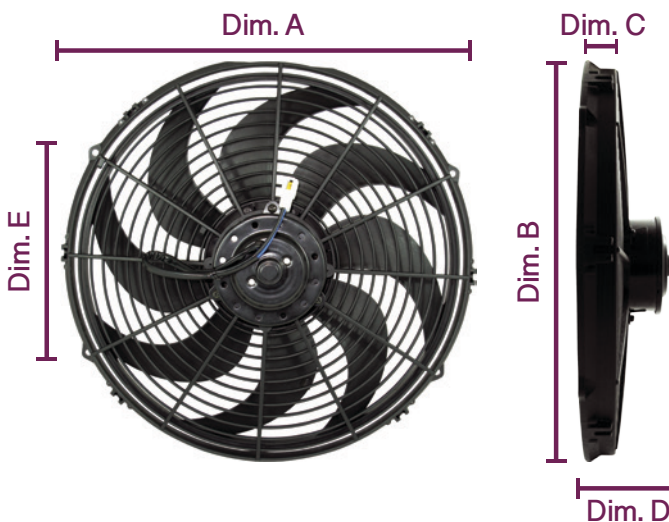

SIZE	PRODUCT NO.	CFM	AMP DRAW	DIM. A	DIM. B	DIM. C	DIM. D	DIM. E
10"	HC7102	650	7.5	10 5/8"	11 1/4"	1 1/4"	2 1/2"	5 5/8"
12"	HC7103	870	10.0	11 5/8"	11 3/4"	1 3/8"	2 1/2"	6 7/16"
14"	HC7104	1,200	12.0	14 7/16"	15 1/4"	1 3/8"	3 1/2"	7 1/8"
16"	HC7105	1,600	14.0	15 5/8"	16"	1 3/8"	3 3/4"	8 1/8"

FAN DIMENSIONS

PRO FLOW FANS

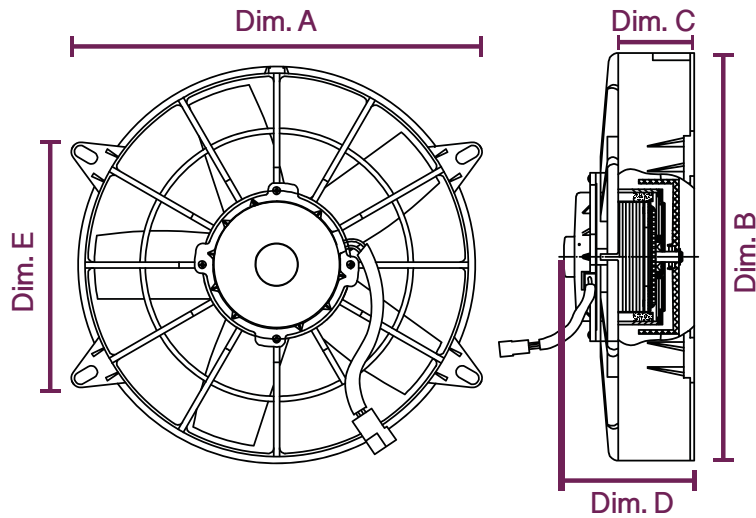

SIZE	PRODUCT NO.	TRUE CFM	AMP DRAW	DIM. A	DIM. B	DIM. C	DIM. D	DIM. E
11"	HC7211	1,400	13.9	11 1/2"	12"	2 1/4"	3 3/4"	6 1/2"
12"	HC7212	1,600	10.0	13 1/4"	13"	2 3/8"	4"	9 3/8"

PRO FLOW FANS

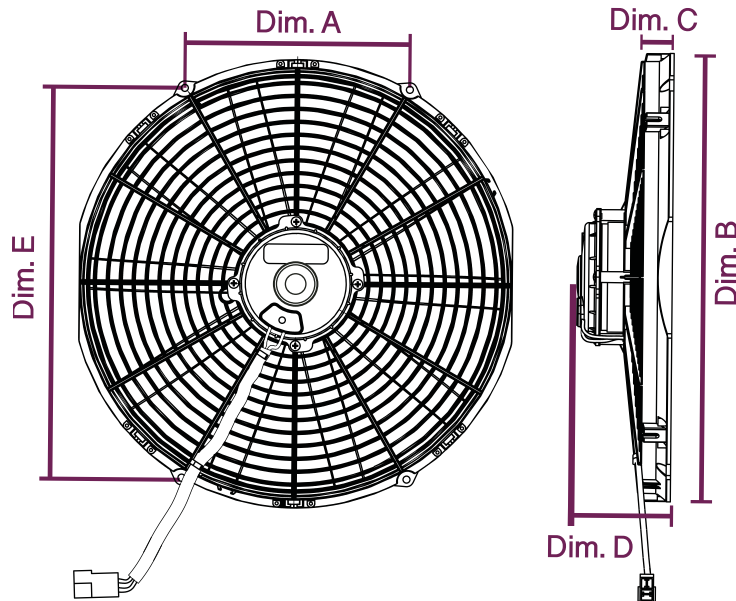

SIZE	PRODUCT NO.	TRUE CFM	AMP DRAW	DIM. A	DIM. B	DIM. C	DIM. D	DIM. E
14"	HC7214	1,800	18	7 1/2"	15"	1 1/2"	3 1/2"	13"
16"	HC7216	2,000	20	8"	16"	1 1/2"	3 1/2"	14"

1-WIRE ALTERNATOR INSTALLATION INSTRUCTIONS

CAREFULLY READ THESE INSTRUCTIONS BEFORE ATTEMPTING INSTALLATION!

INSTALLATION: To install an alternator, disconnect the positive battery cable, unbolt and remove the original alternator, install the alternator and re-tension the drive belts. Then run a single wire of the proper gauge from the alternator 'Battery' terminal to the positive terminal on the battery or to the starter solenoid main lug (connects to the positive battery post). Adjust belt tension so that the belt has approximately 1/2" of deflection and tighten belt tension bolt. Tension belt with hand pressure on alternator (do not use pry bars or anything similar on alternator). Reconnect the positive battery cable, start the engine and using a multi-meter, verify that the alternator is charging at least 13.8 volts at 1000 RPM's.

GROUNDING REQUIREMENTS: In order for an alternator to charge properly, the alternator must be grounded to the engine block. If an alternator has paint or clear-coat on the mounting surfaces, it may not be grounded and will not charge.

CORRECT WIRE SIZE IS CRITICAL: It is very important to use the correct wire size to connect the alternator to the battery. A wire size too small can allow the wire to overheat, melt the insulation and cause a fire or worse. Depending upon the maximum output of the alternator, use the following chart as a minimum wire size guide. Wire size is based on 4' battery cables. Trunk mounted batteries require heavier gauge battery cables - contact Tech Service for recommendation. One wire alternators eliminate the unsightly factory wiring harness and simplifies installation by using only one wire for charging.

AMPERAGE	UP TO 4 FT.	4-7 FT.	7-10 FT.	10-13 FT.	13-16 FT.
35-50	12	12	10	10	10
50-65	10	8	8	6	6
65-85	10	8	8	6	6
85-105	8	8	6	4	4
105-125	6	6	4	4	2
125-150	6	6	4	2	2
150-175	4	4	4	2	2
175-200	4	4	2	2	0

ALTERNATOR DIMENSIONS

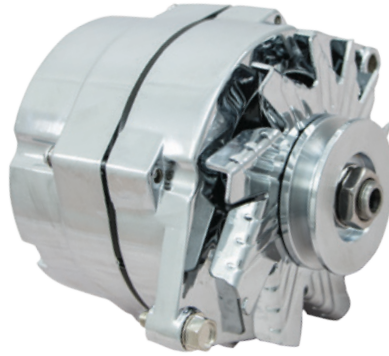
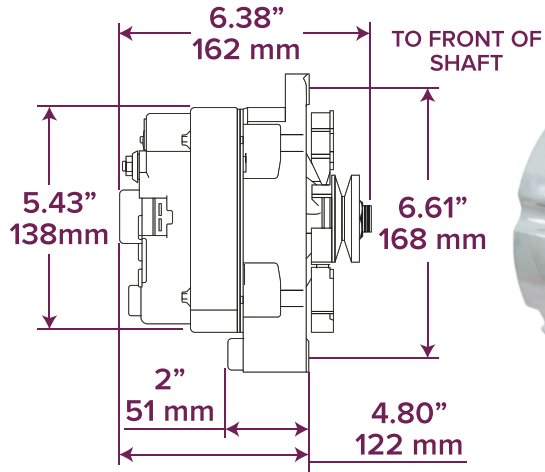

ES1001

GM 10SI Alternator, 110 AMP, V-Belt, 1 or OEM Wire Setup, Fits 1968-1982

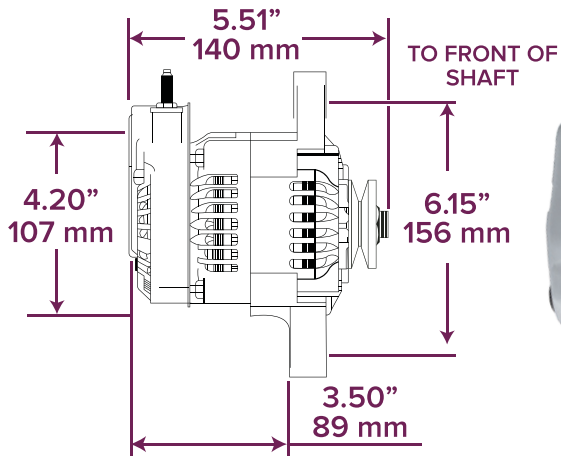

ES1004

GM Mini Denso Style Alternator, Street Rod Race, 90 AMP, 1/2 inch V-Belt, 1-Wire Setup

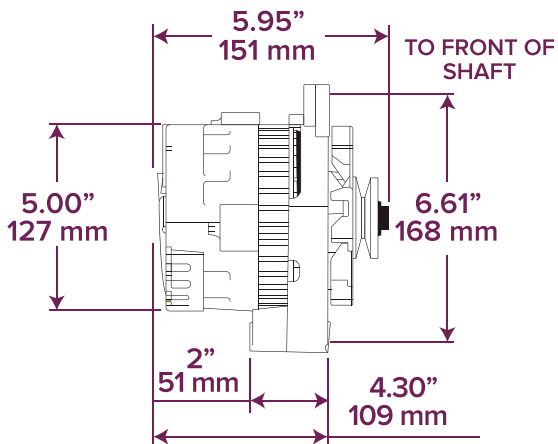

ES1005

GM CS130 Alternator with Side Battery Post, 160 AMP, V-Belt, 1 or OEM Wire Setup, Fits 1968-1995



ES1022

GM CS130 Alternator, 220 AMP, V-Belt, 1 or OEM Wire Setup, Fits 1968-1995

ALTERNATOR DIMENSIONS

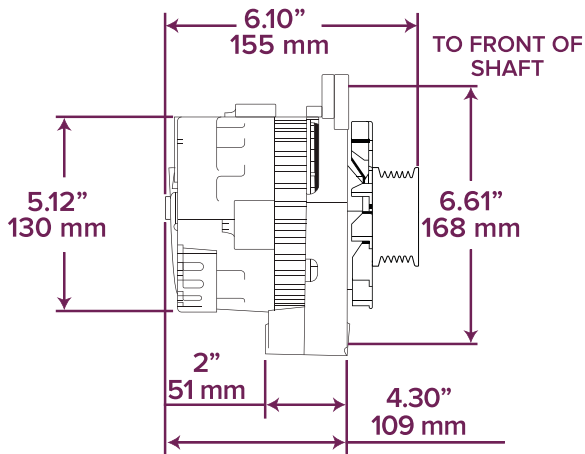

ES1006
GM CS130 Alternator with Side Battery Post, 160 AMP, Serpentine Belt, 1 or OEM Wire Setup, Fits 1968-1995



ES1026
GM CS130 Alternator, 220 AMP, Serpentine Belt, 1 or OEM Wire Setup, Fits 1968-1995

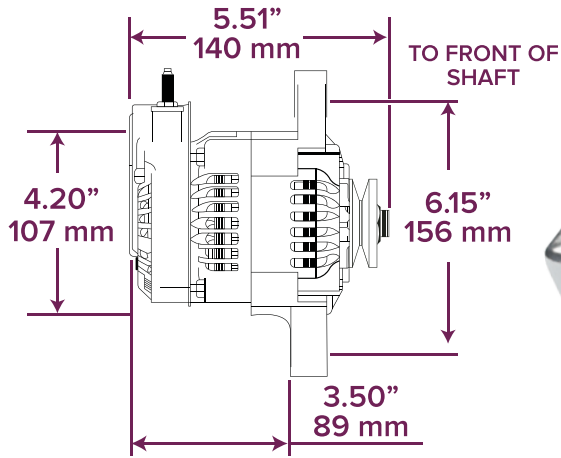

ES1014
GM Mini Denso Style Alternator, Street Rod Race, 90 AMP, 3/8 inch V-Belt, 1-Wire Setup

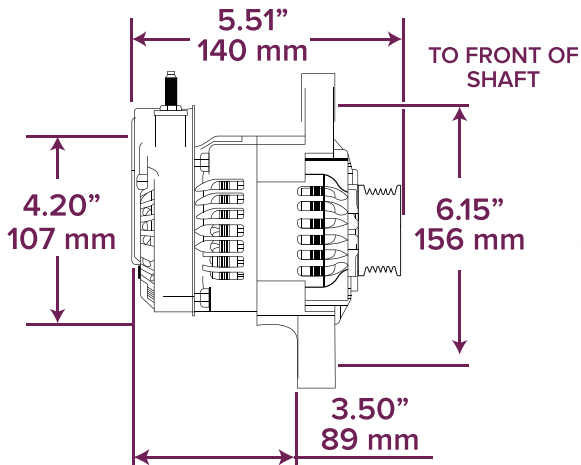

ES1015
GM Mini Denso Style Alternator, Street Rod Race, 90 AMP, Serpentine Belt, 1-Wire Setup

ALTERNATOR DIMENSIONS

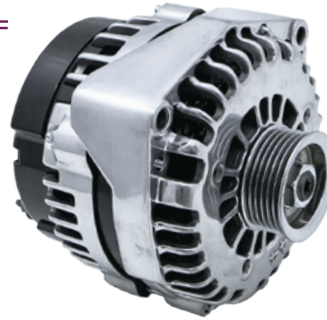
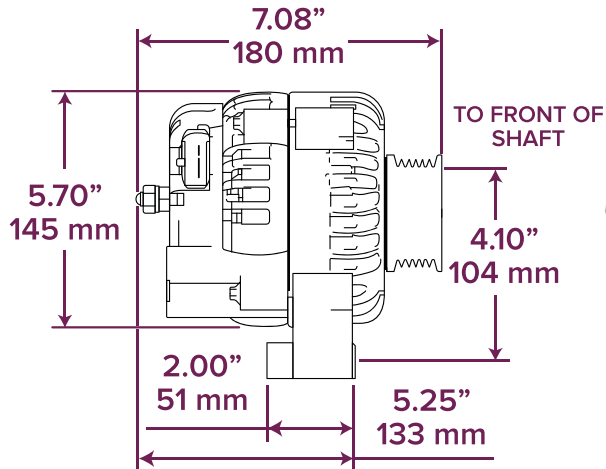

ES1024
 LS Truck AD244 Alternator,
 220 AMP, Serpentine Belt,
 4 Pin Connector

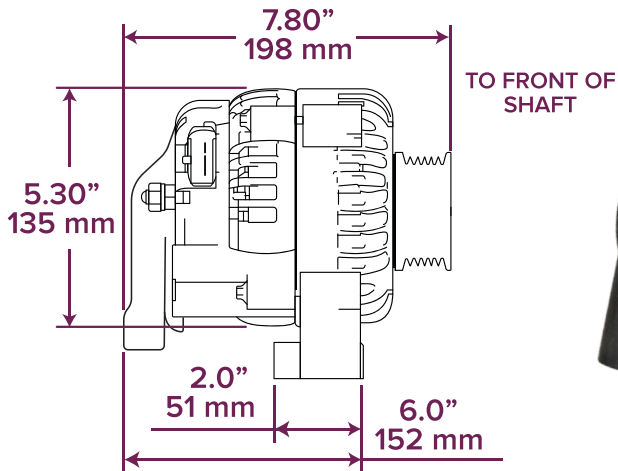

ES1025
 LS Car CS130D Alternator, 180 AMP,
 Serpentine Belt, 4 Pin Connector

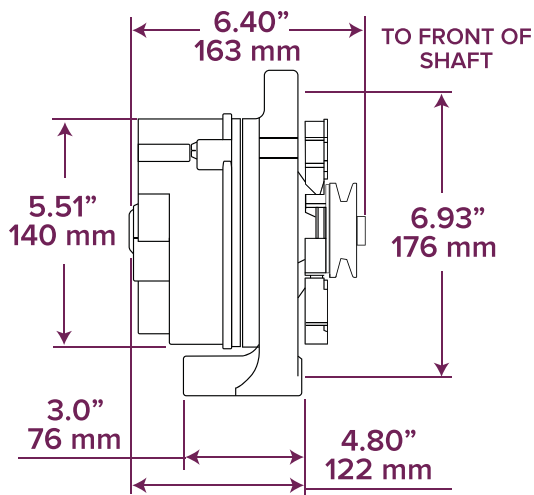

ES1031
 Ford 1G Alternator, 110 AMP, V-Belt,
 1 or OEM Wire Setup, Fits 1963-1986

STARTER DIMENSIONS

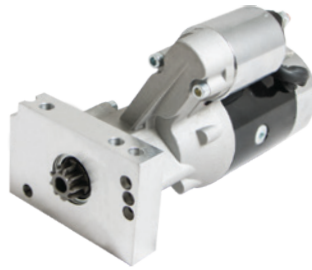
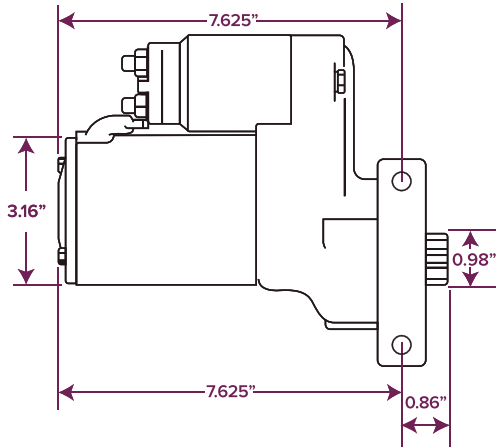

JM7001
Chevy SB/BB 3HP High Torque Starter, 153 or 168 Tooth Flywheel, Tilton Style

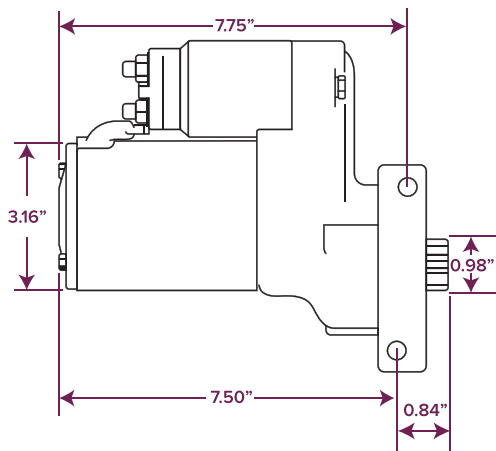

JM7002
LS 3HP High Torque Starter, Tilton Style

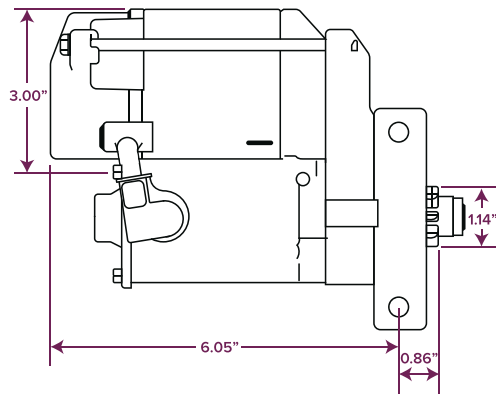

JM7007
Chevy SB/BB 1.9HP Starter, Staggered Mount, Denso Style, 168 Tooth Flywheel

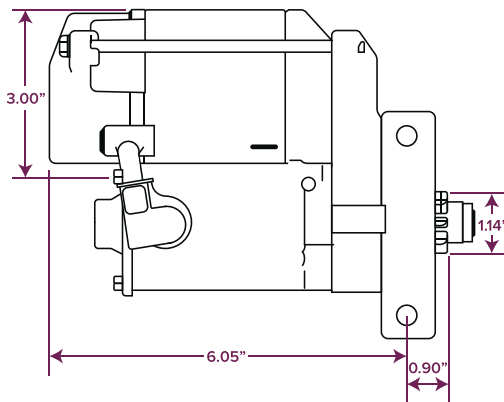

JM7009
LS 1.9HP Starter, Denso Style

A/C COMPRESSOR DIMENSIONS

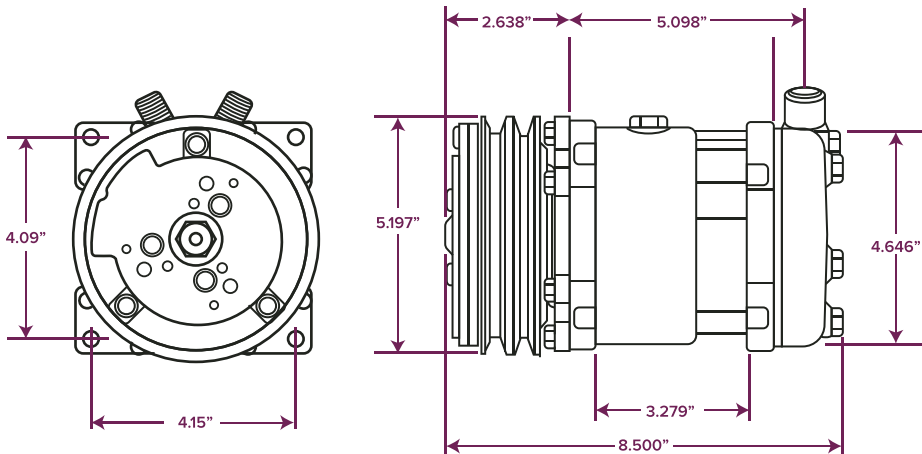

HC5001
Sanden 508 R134A Style
A/C Compressor V-Belt

HC5003
Sanden 508 R134A Style
A/C Compressor V-Belt

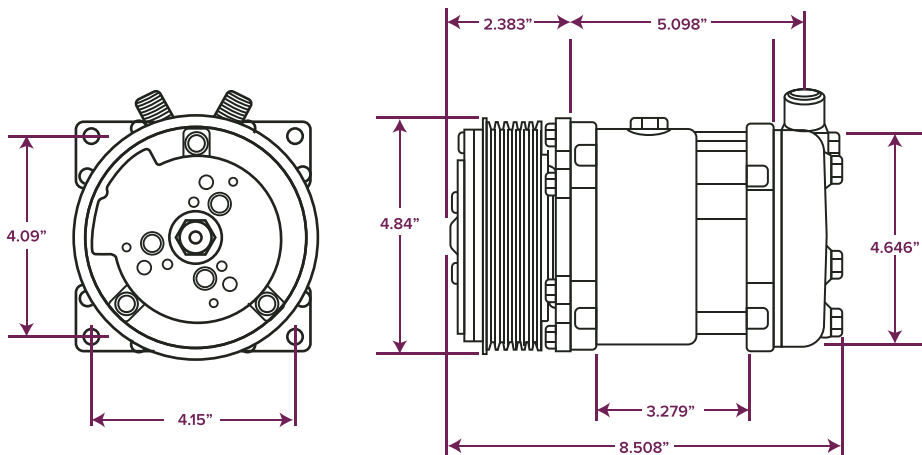

HC5002
Sanden 508 R134A Style
A/C Compressor Serpentine Belt

HC5004
Sanden 508 R134A Style
A/C Compressor Serpentine Belt

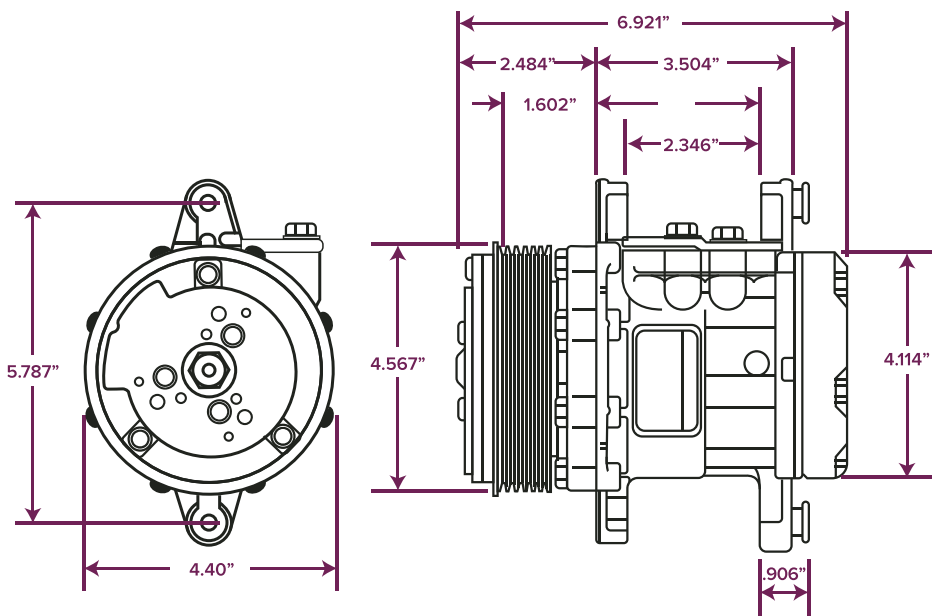

HC5005
Sanden SD-7 Style A/C Compressor
Serpentine Belt, 6 Groove

TSP VELOCITY® LS INTAKE DIMENSIONS

81001: LS1/LS2/LS6 INTAKE MANIFOLD

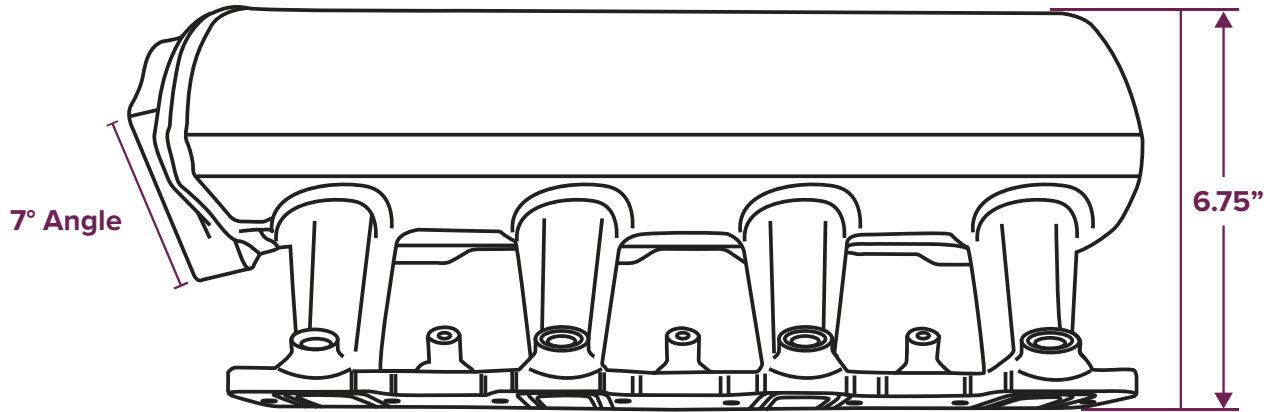

81002: LS1/LS2/LS6 INTAKE MANIFOLD

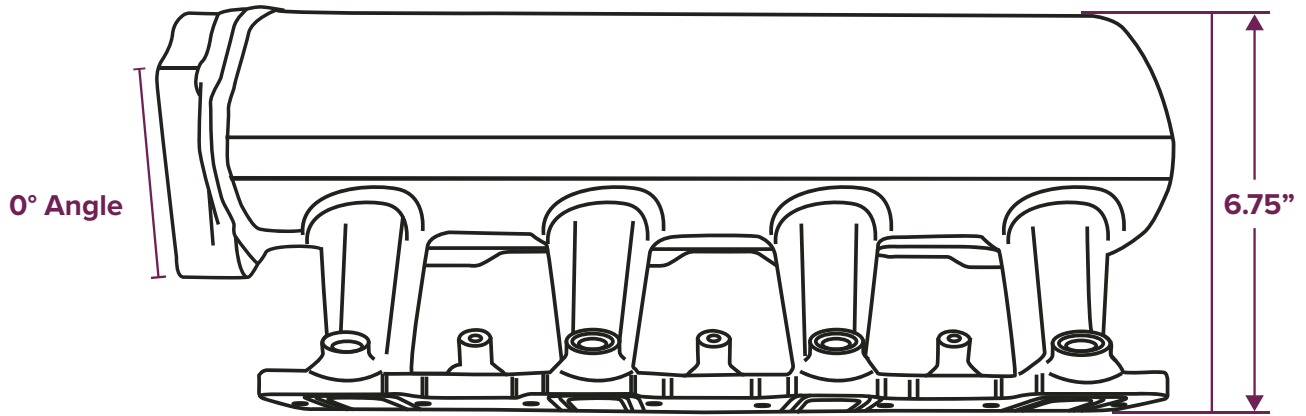

81003: LS3/L92 INTAKE MANIFOLD

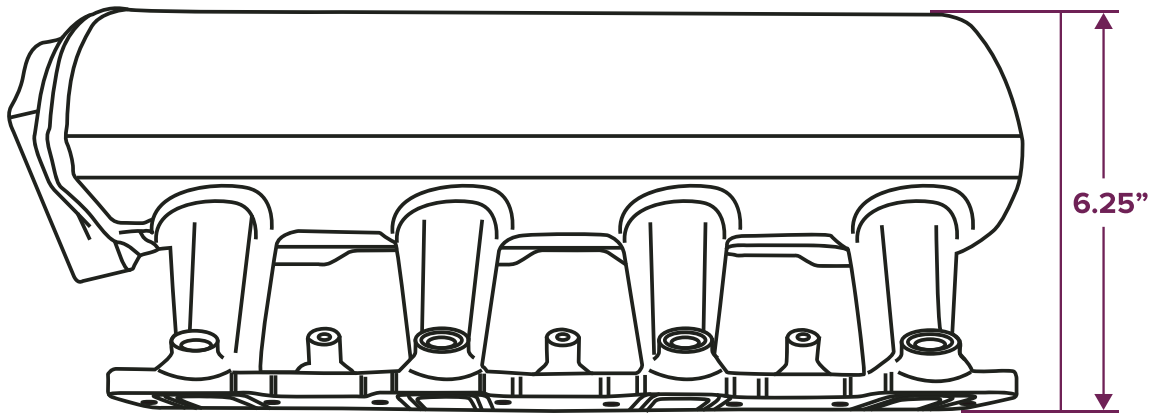

TSP VELOCITY® LS INTAKE DIMENSIONS

81002T: LS1/LS2/LS6 HI-RAM INTAKE MANIFOLD
81003T: LS3/L92 HI-RAM INTAKE MANIFOLD

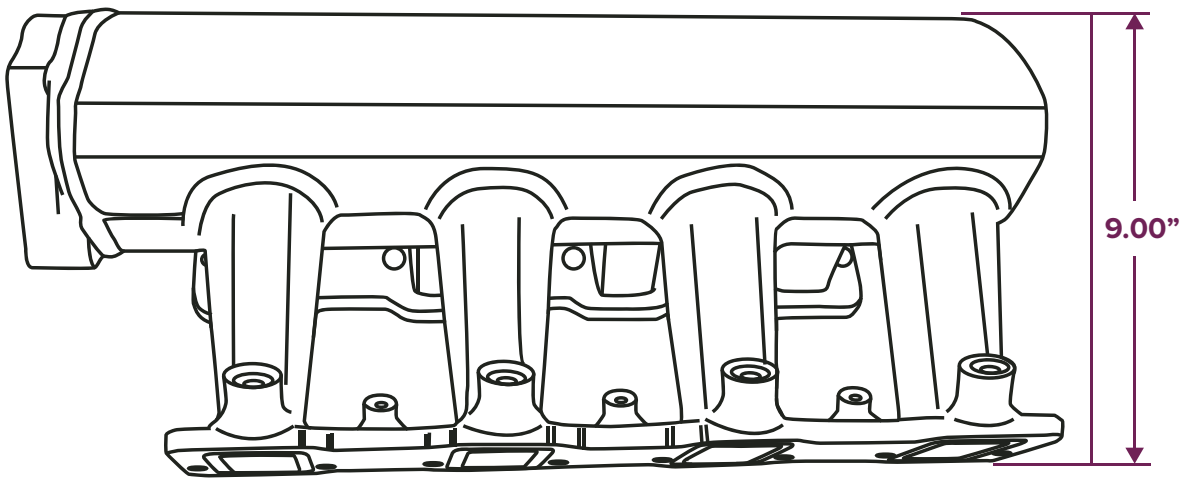

81007: LS7 INTAKE MANIFOLD

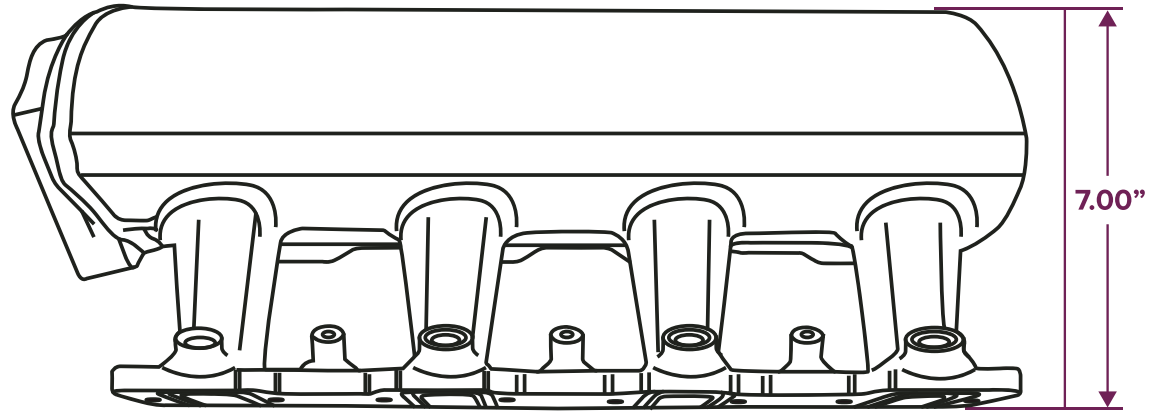

TSP VELOCITY® FORD COYOTE 5.0L INTAKE DIMENSION

84050: FORD COYOTE 5.0L INTAKE MANIFOLD

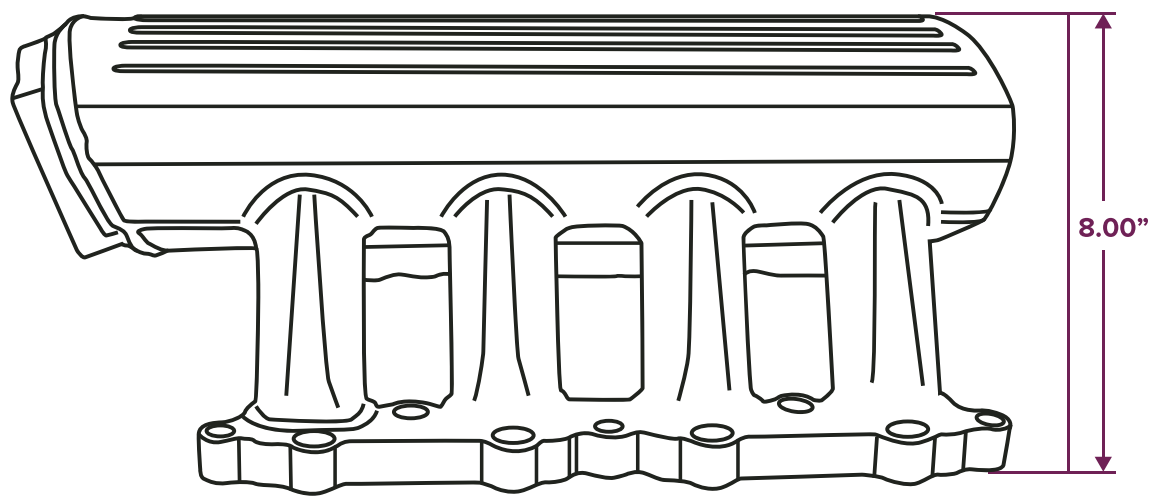

LS OIL PAN DIMENSIONS

81073: LS LOW PROFILE RETRO FIT OIL PAN

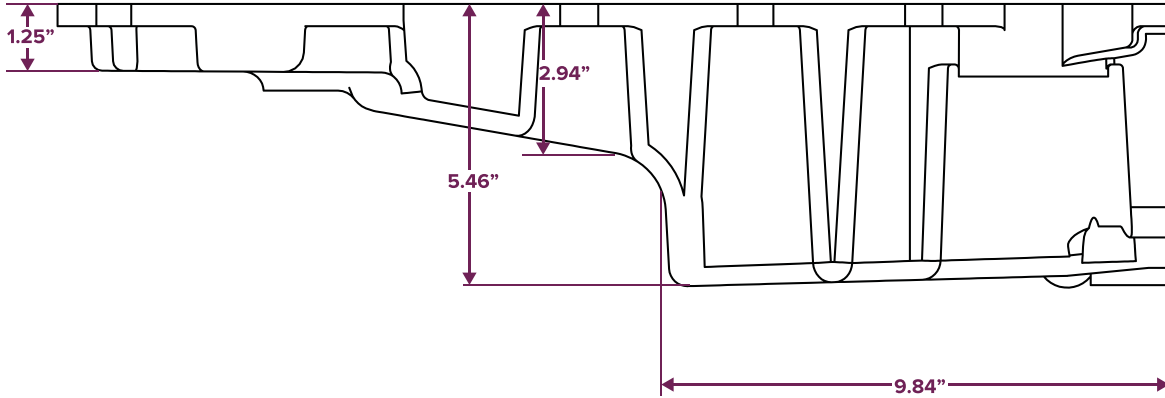

81074: LS RETRO FIT OIL PAN

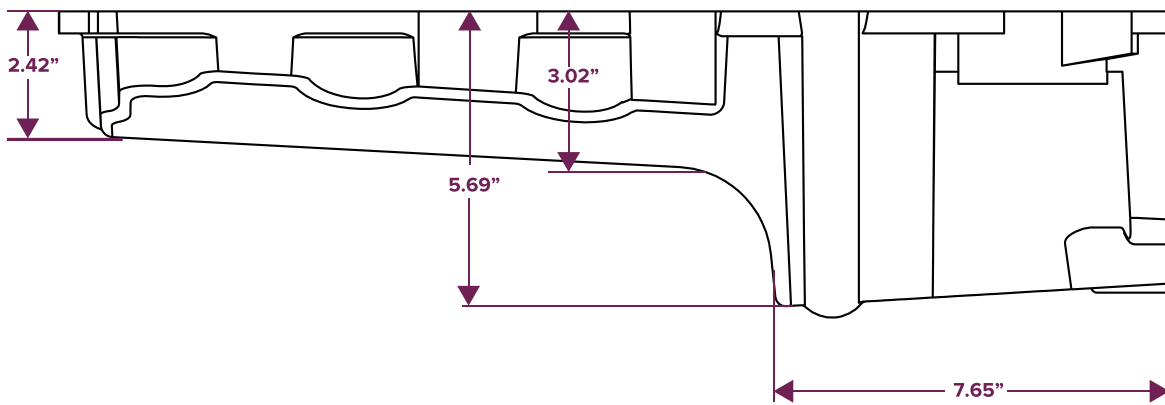

81075: LS LOW PROFILE RETRO FIT OIL PAN, FRONT SUMP

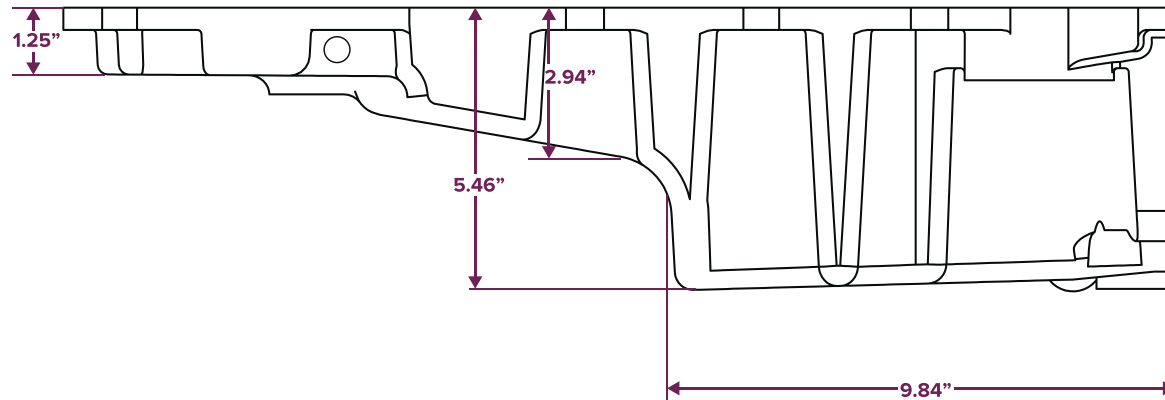

81076: LS RETRO FIT OIL PAN, FRONT SUMP

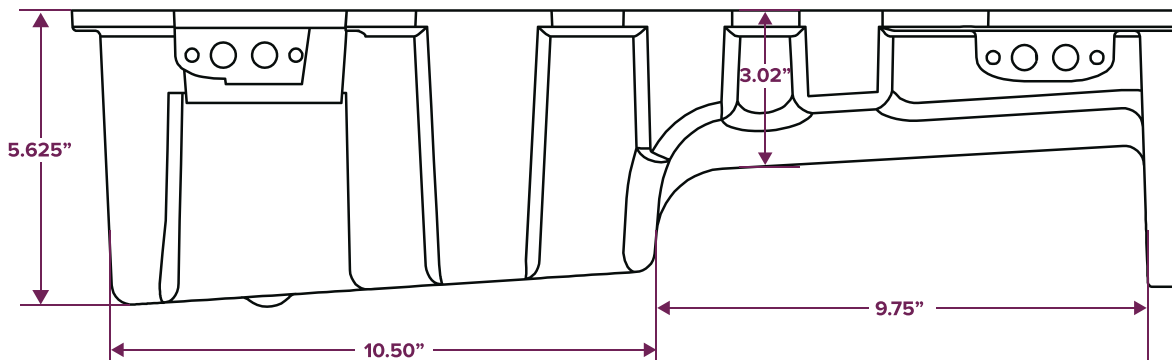

LS RELOCATION BRACKETS DIMENSION

LS CAR RELOCATION KIT DIMENSION

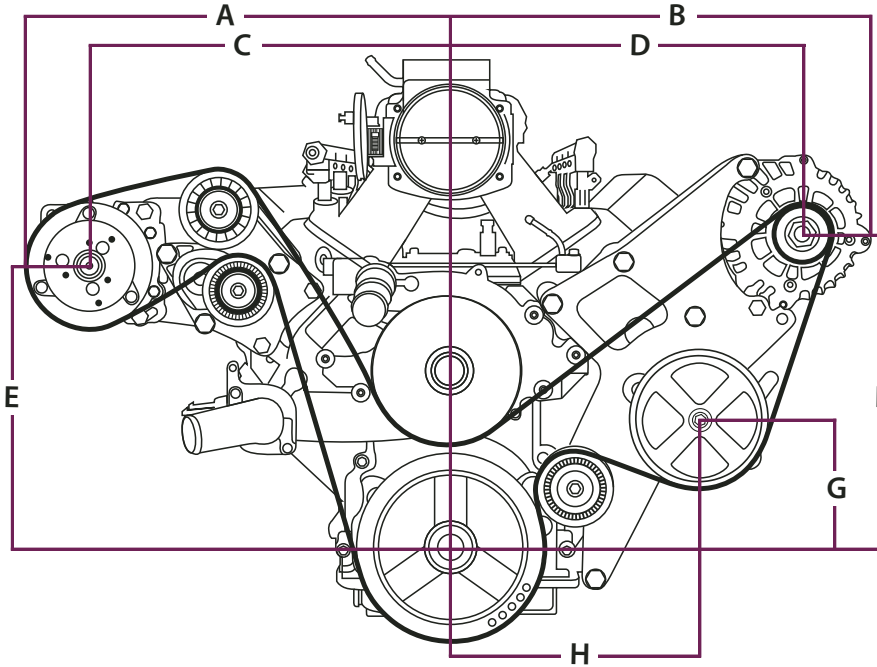

PART	DIMENSIONS
A	16.60"
B	16.68"
C	14.16"
D	13.80"
E	11.51"
F	12.47"
G	5.39"
H	9.53"

LS TRUCK RELOCATION KIT DIMENSION

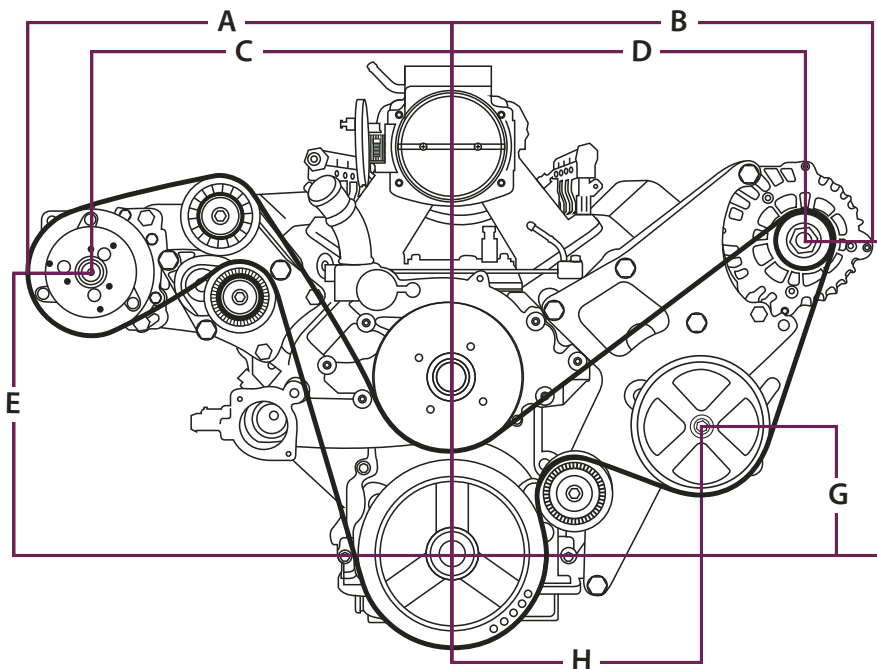

PART	DIMENSIONS
A	16.60"
B	16.68"
C	14.16"
D	13.80"
E	11.51"
F	12.47"
G	5.39"
H	9.53"

VALVE COVER DIMENSIONS

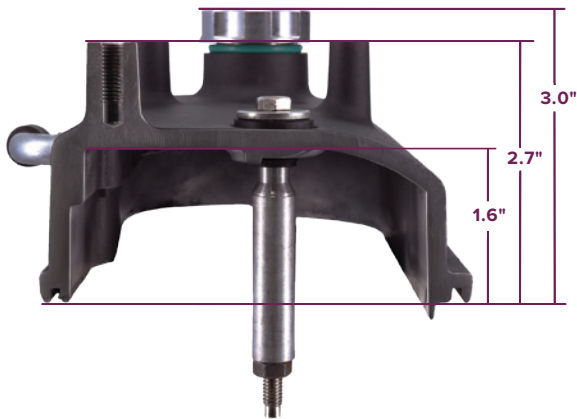

JM8082-1
 LS Aluminum Tall Cast Valve Cover,
 Center Bolt with Coil Mounts, Oil Filler Hole

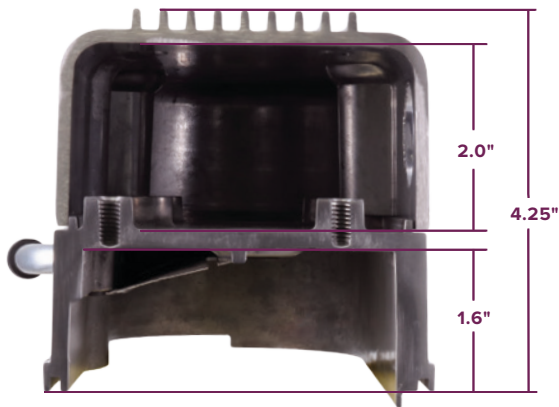

JM8082-2
 LS Aluminum Finned Cast Valve Cover
 and Coil Cover, Center Bolt with Coil Mounts

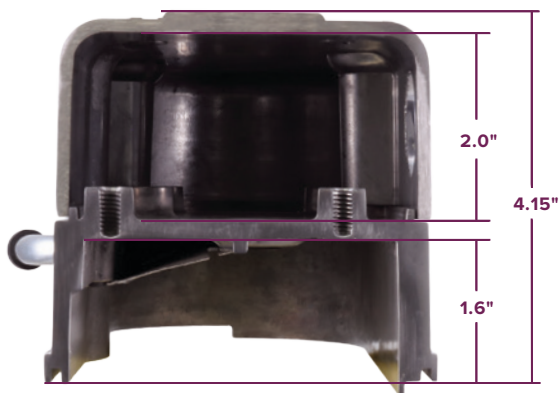

JM8082-3
 LS Aluminum Smooth Cast Valve Cover
 and Coil Cover, Center Bolt with Coil Mounts