



TSP

TOP STREET PERFORMANCE

2019

PRODUCT CATALOG

ABOUT THE COMPANY



Top Street Performance is a privately-owned company based in Southern California. We have a respectable history in the automotive aftermarket industry, cultivating relationships with a network of quality parts manufacturers along the way. This means that we are able to provide premium parts and bargain pricing, all guaranteed by our one-year warranty.

Thanks to our hard work and dedication, we have been fortunate enough to enjoy steady growth over the past several years. We recently moved from an 18,000 ft² warehouse in Downey to a 52,000 ft² facility in Santa Fe Springs. This has allowed us to stock more products, ship orders more quickly and efficiently, and increase our sales and support teams to accommodate more customers.

Customer service is at the center of everything we do at Top Street Performance. Whether you're looking for a part or two for your resto-mod or performance upgrade, or whether you're a shop or distributor looking to add TSP's high-quality performance parts to your product line, we've got you covered. Our friendly and knowledgeable staff is ready to assist you in anything you may need.

TSP is a proud member of the Specialty Equipment Market Association (SEMA) and an authorized retailer of premium products from industry-leaders Taylor Cable, K&N Engineering®, and now AEM Electronics®.

Top Street Performance: Quality. Performance. Period.



FORD COYOTE 5.0L**3**

Ford Coyote 5.0L	3-4
------------------------	-----

LS PRODUCTS**5**

LS Serpentine Pulley Kit	5-6
LS Car Relocation Kit	7-8
LS Truck Relocation Kit	9-10
Velocity® by TSP Products	11-12
Velocity® by TSP Induction Kits	13-14
LS Valve Covers, LS Coil Covers, LS Oil Pans	15-16
Other LS Products	17-19
LS Coil Relocation Kit	21-22

IGNITION**23**

Pro Series Pro Billet Distributors	23-25
Power Pack Ignition Kit	26
Pro Series Ready to Run Distributors	27-31
Pro Series Ready to Run Kit	32
HEI Distributors	33-37
Pro Billet Distributors	39-40
Ready to Run Distributors	41-42
EFI Distributors	43-44
Ignition Accessories	45-56
Taylor Spark Plug Wire Sets	56
TSP Ignition Wire Sets	57-58

ELECTRICAL**59**

Alternators	59-61
Starters	63-64

COOLING**66**

Mechanical Water Pumps	65-67
Electric Water Pumps	68
Water Necks	68
Radiators	69-70
Flap, Radiator Cap, Radiator Hose Kit, Heater Hose Kit	71
Universal Transmission Oil Coolers	72
Fan Shrouds	73
Fan Shroud Kits	74
Overflow Tanks	75
A/C Compressors	76
Electric Cooling Fans, Fan Accessories	77-80

FRONT DRIVE SYSTEM**81**

SBC & BBC Front Drive System	81-82
SBF Front Drive System	82

BRACKETS & PULLEYS**83**

Bracket Kits	83-85
Gilmer Style Pulley Kits	86-88
Pulleys	89-92

INTAKE MANIFOLDS**93**

Intake Manifolds	93-94
------------------------	-------

HARMONIC BALANCERS**95**

Harmonic Balancers	95-96
--------------------------	-------

DRESS UP**97**

GM LS Valve Covers	97-98
Chevy Valve Covers	98-99
Ford Valve Covers	100-101
Ford FE Valve Covers	101
Mopar Valve Covers	101
Valve Cover Gaskets	102-103
Push-in Breathers	104
Clamp-on Breathers	105
Oil Plugs & Cap	105
Air Cleaner Kits	106
Oil Pans	107-110
Oil Pan Pick-ups	110-111
Oil Pan Gaskets	111
Transmission Oil Pans, Transmission Oil Pan Gaskets	112
Mirrors, Window/Door Handles	113-114
Polished Aluminum Knobs	114
Gas & Brake Pedals	114-115

FUEL DELIVERY**117**

Electric Fuel Pump and Filter Mounting Bracket Kit	117-118
Electric Fuel Pumps and Fuel Regulators	119-120
Mechanical Fuel Pumps	121-123
Fittings, Block Off Plates	123-124
Gauges, Throttle Cable Bracket	124
Carb Spacers & Adapters	124-125
Throttle, Kick-Down & Choke Cables, Fuel Lines	126-127
Phenolic Manifold Heat Spacers	127
Manifold Heat Spacer Gaskets	127

STEERING**129**

Power Steering Pumps	129-130
Steering Covers & Cap	130
Steering Box	130

HOT RODS**131**

Hi-Boy, Lo-Boy Radiators	131
'32 Ford Grill Shells	132

BLACK SERIES**133****INSTRUCTIONS & DIAGRAMS****139**

Distributors Installation	139-140
Distributor Cap Dimensions	140
Fan Dimensions	141-142
Alternator Dimensions & Installation	143-144
Starter Dimensions	145
A/C Compressor Dimensions	146
Velocity® by TSP LS Intake Manifold Dimensions	147-148
Velocity® by TSP Ford Coyote 5.0L Intake Manifold	148
LS Oil Pan Dimensions	149

FORD COYOTE 5.0L

Valve Cover

- Fabricated Aluminum
- Hardware, Gasket and Dipstick Included

Fabricated Intake Manifold

- 90mm Throttle Body Opening
- Fabricated Aluminum
- Embossed Design
- 6 in. Intake Runners



Power Steering Kit

- SD-7 A/C Compressor
- GM Type II Power Steering Pump
- Hardware and Bracket Included
- Idler Pulley

Ignition Coil

- 45,000 Volts
- Primary Resistance: 760 ohms
- Spark Duration: 1.8 ms



84050

BK CA

Velocity® Ford Coyote 5.0L Embossed Intake Manifold



84052

BK P

Ford Coyote 5.0L Fabricated Aluminum Valve Cover, Perimeter Bolt



84053

BK P

Ford Coyote 5.0L Hydraulic Power Steering Kit



JM6809-8

BL

Ford Coyote 5.0L Ignition Coil, 8pc/Set

FORD COYOTE 5.0L

84050

Velocity® 2011+ Ford Coyote 5.0L Embossed, EFI Fabricated Aluminum Intake Manifold
Black, Clear Anodized

84051

Velocity® Ford Coyote 5.0L Billet Aluminum Fuel Rail Kit
Black, Silver

84052

Ford Coyote 5.0L Fabricated Aluminum Valve Cover, Perimeter Bolt, Oil Filler Hole
Black, Polished

84053

Ford Coyote 5.0L Hydraulic Power Steering Kit
Black, Polished
**Water pump pulley not shown*

84750

84050 Replacement Gaskets and Mounting Bolts

JM6809-8

Ford Coyote 5.0L 2011-2016 V8 Engine Ignition Coil, 45K Volt, 8pc/Set
Blue

FORD COYOTE 5.0L VALVE COVER

- Fabricated Aluminum
- One-Piece Billet Aluminum Mounting Surface
- Rubber Grommets
- CNC Machined Oil Filler Cap
- Hardware and Gasket Included
- Dipstick

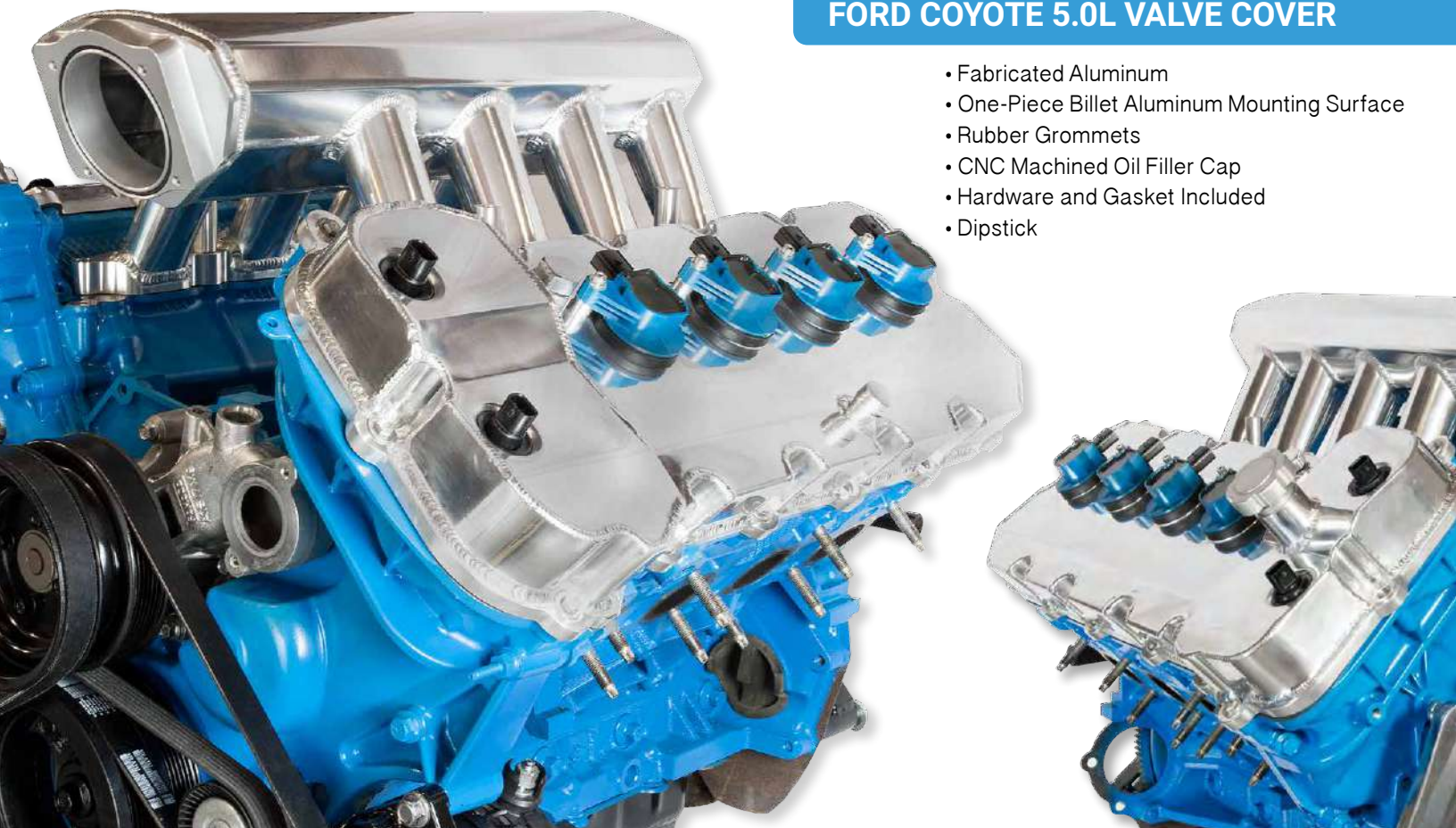



LS Serpentine Pulley Kit Includes:

- 6061-T6 Billet Aluminum Brackets
- GM CS130 Alternator, 160 AMP
- Sanden SD-7 Style A/C Compressor
- A/C Compressor Manifold
- GM Type II Power Steering Pump
- TSP LSX Customized Aluminum Mechanical Water Pump
- Polished Aluminum Idler Pulley
- Custom Designed Billet Aluminum Tensioner
- 6061-T6 Billet Aluminum Pulleys
- TSP LSX SFI Certified Harmonic Balancer Steel Damper
- Serpentine Belt
- Step by Step Instructions

** Will not work with variable valve timing engines.
 * NOT for hydroboost engines*

81200ABK
 LS Serpentine Pulley Kit
 All Black

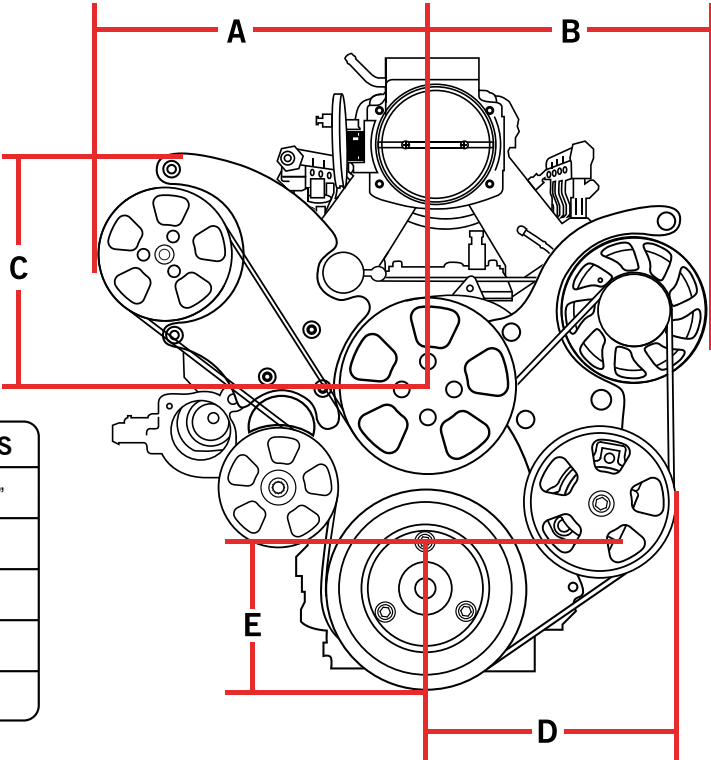

TO FRONT FACE OF	FROM BLOCK FACE	DIMENSIONS
A/C COMPRESSOR COVER	7.75"	PART A: 11 1/2"
ALTERNATOR PULLEY	6.85"	PART B: 10"
WATER PUMP PULLEY	7.00"	PART C: 7 1/2"
POWER STEERING PULLEY	6.50"	PART D: 8 1/2"
CRANKSHAFT PULLEY	6.50"	PART E: 5"



HC5005

BK CH

Sanden SD-7 Style A/C Compressor
Serpentine Belt



JM2010

BK CH S

GM Type II Power Steering Pump

**LS SERPENTINE
PULLEY KIT: 81200**

HC5005

Sanden SD-7 Style A/C Compressor
Serpentine Belt, 6 Groove, Silver Clutch
Black, Chrome

JM2010

GM Type II Power Steering Pump
-10AN Inlet, -6AN Outlet
Black, Chrome, Satin

ES1006

GM CS130 Alternator, 160 AMP,
Serpentine Belt, 1 Wire or OEM Wire
Setup, Side Battery Post
Fits 1968-1995
Chrome

HC8936

TSP LSX Customized Aluminum Mechanical
Water with Hub for
81200 Serpentine Front End Kit
Black, Chrome

81102

TSP LSX SFI Certified Harmonic Balancer
Steel Damper, 360° Markings
Black



ES1006

BK CH

GM CS130 Alternator, Serpentine Belt,
160 AMP



HC8936

BK CH

TSP LSX Customized Aluminum
Mechanical Water Pump with Hub

SERPENTINE KIT ALSO AVAILABLE IN DIFFERENT FINISHES



81200BK
LS Serpentine Pulley Kit
Black

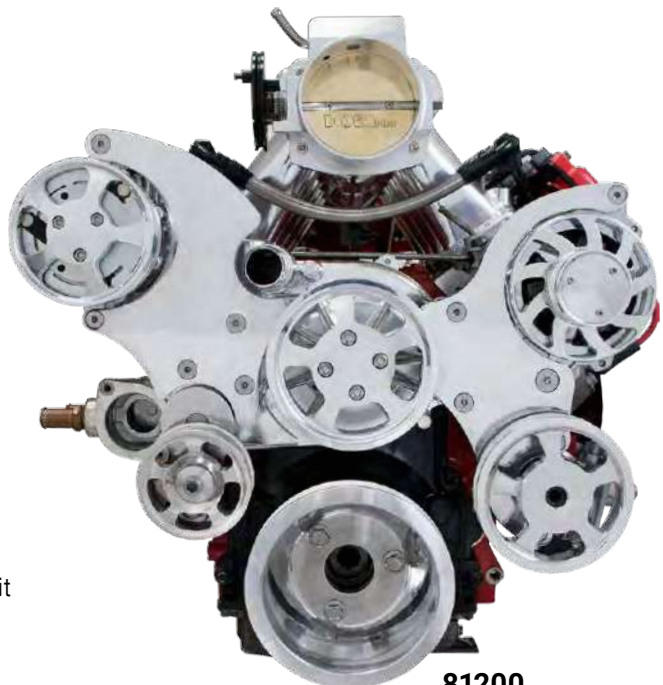

81200
LS Serpentine Pulley Kit
Polished

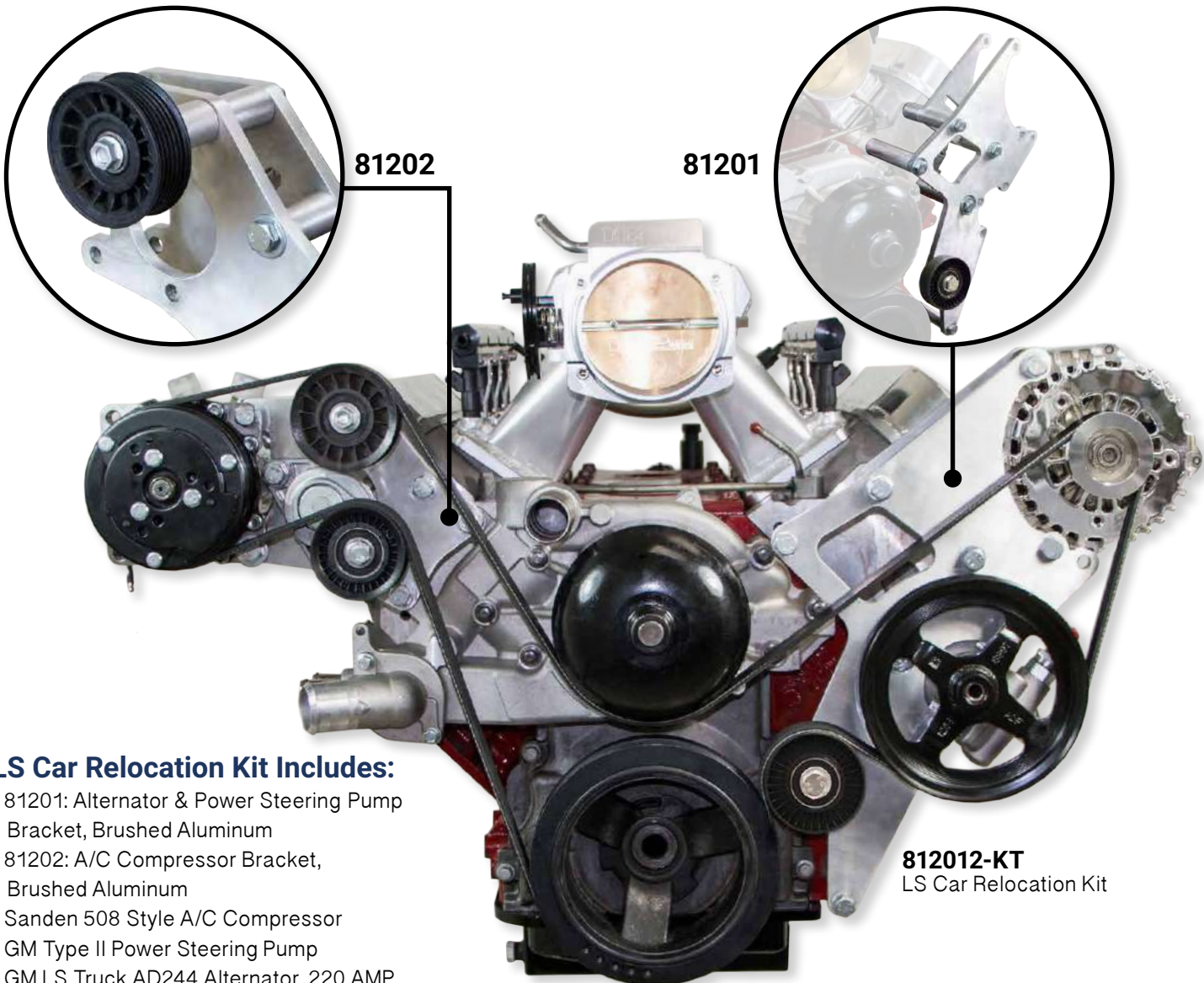

LS Car Relocation Kit Includes:

- 81201: Alternator & Power Steering Pump Bracket, Brushed Aluminum
- 81202: A/C Compressor Bracket, Brushed Aluminum
- Sanden 508 Style A/C Compressor
- GM Type II Power Steering Pump
- GM LS Truck AD244 Alternator, 220 AMP
- GM LS1/LS2/LS6 Car Aluminum Mechanical Water Pump
- 2 Idler Pulley
- Power Steering Pulley GM #12568997
- Belt
- Step by Step Instructions

812012-KT
LS Car Relocation Kit

PART	DIMENSIONS
A	16.60"
B	16.68"
C	14.16"
D	13.80"
E	11.51"
F	12.47"
G	5.39"
H	9.53"

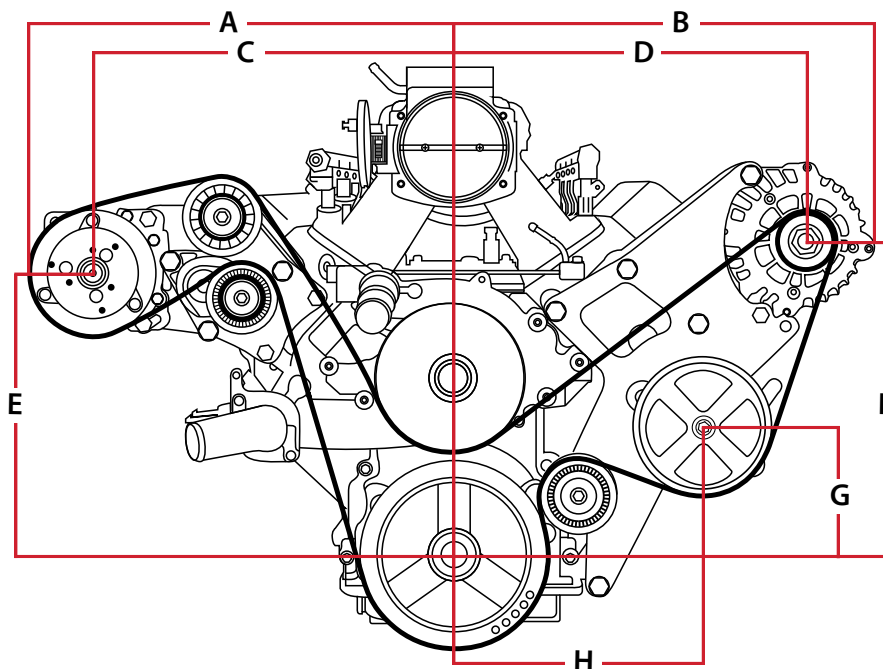



HC5002

BK CH

Sanden 508 Style A/C Compressor
Serpentine Belt



JM2010

BK CH S

GM Type II Power Steering Pump



ES1024

BK CH

GM LS Truck AD244 Alternator,
Serpentine Belt, 220 AMP



HC8934*

S

GM LS1/LS2/LS6 Car Aluminum
Mechanical Water Pump



81201

BK N

TSP LS1/LS2 '98-'02 Camaro and
Firebird/GTO, Alternator & Power
Steering Pump Relocation Bracket



81202

BK N

TSP LS1/LS2 '98-'02 Camaro and
Firebird/GTO, A/C Compressor
Relocation Bracket



81201-KT

BK N

TSP LS1/LS2 Car Alternator & Power
Steering Relocation Bracket Kit

**LS CAR RELOCATION KIT:
812012-KT**

HC5002

Sanden 508 R134A Style
A/C Compressor Serpentine Belt,
Black Clutch
Black, Chrome

JM2010

GM Type II Power Steering Pump
-10AN Inlet, -6AN Outlet
Black, Chrome, Satin

ES1024

GM LS Truck AD244 Alternator,
220 AMP, Serpentine Belt,
4 Pin Connector
Black, Chrome

HC8934*

GM LS1/LS2/LS6 Car, Aluminum
Mechanical Water Pump
Fits 1997-2006, OEM Replacement
Satin

81201

TSP LS1/LS2 '98-'02 Camaro and
Firebird/GTO, Alternator & Power Steering
Pump Relocation Bracket, Brushed
Aluminum
Black, Natural

81202

TSP LS1/LS2 '98-'02 Camaro and
Firebird/GTO, A/C Compressor
Relocation Bracket, Brushed Aluminum
Black, Natural

81201-KT

TSP LS1/LS2 Car Alternator & Power
Steering Relocation Bracket Kit,
Brushed Aluminum
Black, Natural

* OEM Replacement

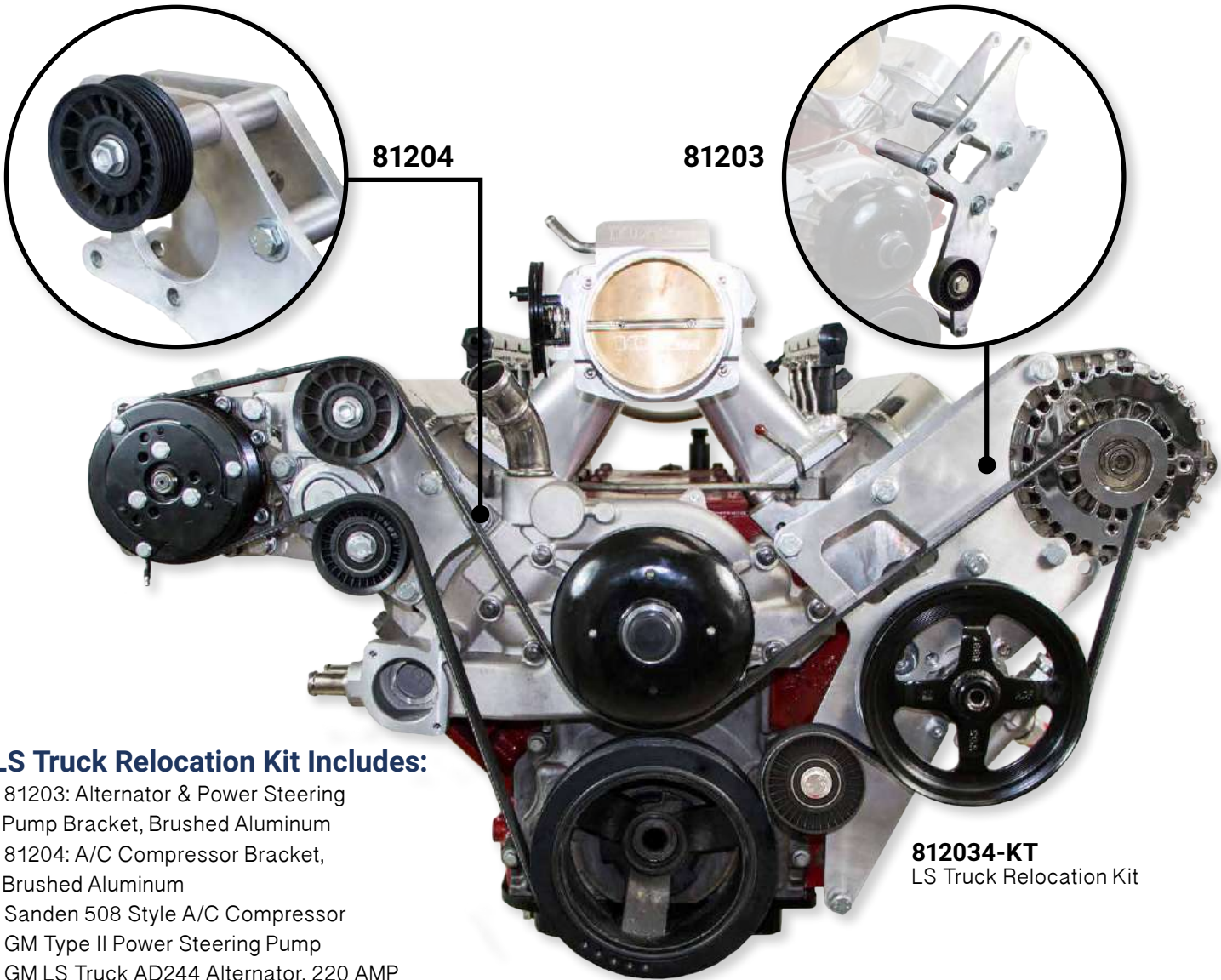

LS Truck Relocation Kit Includes:

- 81203: Alternator & Power Steering Pump Bracket, Brushed Aluminum
- 81204: A/C Compressor Bracket, Brushed Aluminum
- Sanden 508 Style A/C Compressor
- GM Type II Power Steering Pump
- GM LS Truck AD244 Alternator, 220 AMP
- GM LSX Truck Aluminum Mechanical Water Pump
- 2 Idler Pulley
- Power Steering Pulley GM #12568997
- Belt
- Step by Step Instructions

812034-KT
LS Truck Relocation Kit

PART	DIMENSIONS
A	16.60"
B	16.68"
C	14.16"
D	13.80"
E	11.51"
F	12.47"
G	5.39"
H	9.53"

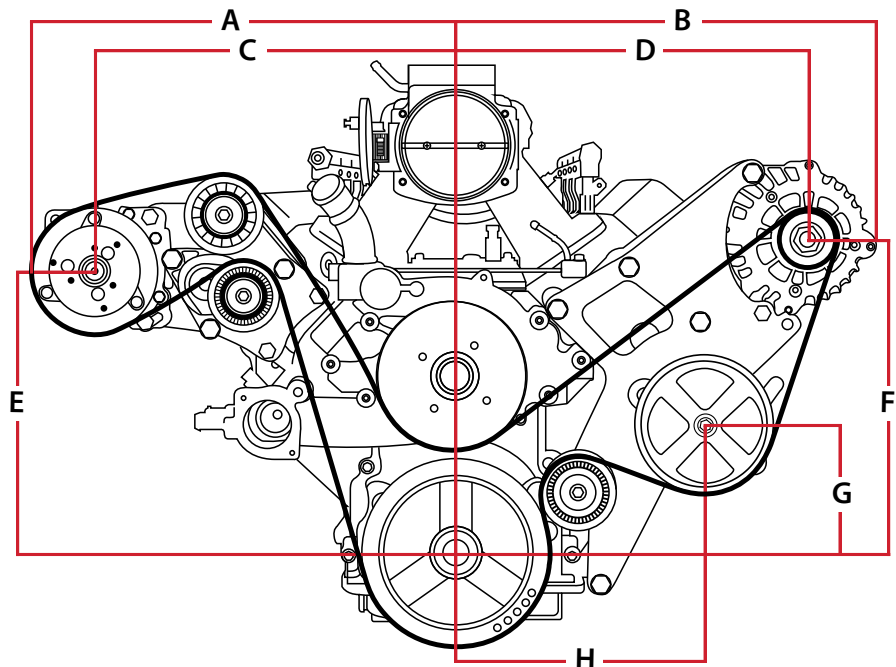



HC5002 BK CH
 Sanden 508 Style A/C Compressor
 Serpentine Belt



JM2010 BK CH S
 GM Type II Power Steering Pump



ES1024 BK CH
 GM LS Truck AD244 Alternator,
 Serpentine Belt, 220 AMP



HC8935* S
 GM LSX Truck 4.8L/5.3L/6.0L Aluminum
 Mechanical Water Pump



81203 BK N
 TSP LS Truck '99+/Gen 5 Camaro
 2010+ Alternator & Power Steering
 Pump Relocation Bracket



81204 BK N
 TSP LS Truck '99+/Gen 5 Camaro
 2010+ A/C Compressor Relocation
 Bracket



81203-KT BK N
 TSP LS Truck Alternator & Power
 Steering Relocation Bracket Kit

LS TRUCK RELOCATION KIT: 812034-KT

HC5002
 Sanden 508 R134A Style
 A/C Compressor Serpentine Belt,
 Black Clutch
 Black, Chrome

JM2010
 GM Type II Power Steering Pump
 -10AN Inlet, -6AN Outlet
 Black, Chrome, Satin

ES1024
 GM LS Truck AD244 Alternator, 220 AMP,
 Serpentine Belt, 4 Pin Connector
 Black, Chrome

HC8935*
 GM LSX Truck 4.8L/5.3L/6.0L,
 Aluminum Mechanical Water Pump
 Fits 1999-2006, OEM Replacement
 Satin

81203
 TSP LS Truck '99+/Gen 5 Camaro 2010+
 Alternator & Power Steering Pump
 Relocation Bracket, Brushed Aluminum
 Black, Natural

81204
 TSP LS Truck '99+/Gen 5 Camaro 2010+
 A/C Compressor Relocation Bracket,
 Brushed Aluminum
 Black, Natural

81203-KT
 TSP LS Truck Alternator & Power Steering
 Relocation Bracket Kit, Brushed Aluminum
 Black, Natural

* OEM Replacement

VELOCITY[®] BY TSP

VELOCITY[®]



81001:

- Velocity[®] LS1/LS2/LS6 Fabricated Intake Manifold
- 6061-T6 Aluminum
- 102mm Throttle body opening
- Velocity stacked intake runners
- Runners length are 5.0 inches long
- 3mm thick aluminum
- Compatible with Map Sensor GM 12592525
- 7 degree front angle
- Overall Height: 6.75 inches
- Finish: Black, Clear Anodized



Velocity stacks for better air flow



Compatible with Map Sensor
GM 12592525

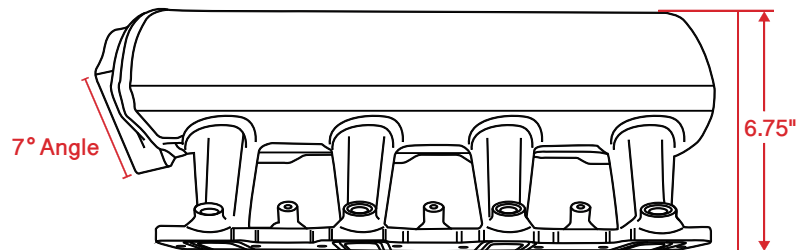



81002T

BK CA

Velocity® LS1/LS2/LS6 Hi Ram Intake Manifold



81003

BK CA

Velocity® LS3/L92 Intake Manifold



81007

BK CA

Velocity® LS7 Intake Manifold



81008

BK SL

Velocity® LS1/LS2/LS6 Billet Aluminum Fuel Rail Kit



81009

BK SL

Velocity® LS3 Billet Aluminum Fuel Rail Kit



81012

BK M

Velocity® 102mm 4-Bolt LSX Throttle Body

81002

Velocity® LS1/LS2/LS6, 102mm Fabricated Aluminum Intake Manifold, 0° Angle
Black, Clear Anodized

81002T (Tall Version)

Velocity® LS1/LS2/LS6, 102mm Hi-Ram Fabricated Aluminum Intake Manifold, 0° Angle
Black, Clear Anodized

81003

Velocity® LS3/L92, 102mm Fabricated Aluminum Intake Manifold
Black, Clear Anodized

81003T (Tall Version)

Velocity® LS3/L92, 102mm Hi-Ram Fabricated Aluminum Intake Manifold
Black, Clear Anodized

81007

Velocity® LS7, 102mm Fabricated Aluminum Intake Manifold
Black, Clear Anodized

81008

Velocity® LS1/LS2/LS6 Billet Aluminum Fuel Rail Kit
Black, Silver

81009

Velocity® LS3/L92 Billet Aluminum Fuel Rail Kit
Black, Silver

81011

Velocity® LS7 Billet Aluminum Fuel Rail Kit
Black, Silver

81012

Velocity® 102mm 4-Bolt LSX Throttle Body
Black, Machined

81014

Velocity® 102mm 4-Bolt Fly-by-Wire Throttle Body
Black, Machined

81042

Velocity® 92mm 4-Bolt LSX Throttle Body
Black, Machined

81050-36 (36 lbs/hr.)

Velocity® LS1/LS2/LS6/Ford Coyote 5.0L High-Flow Fuel Injector

81050-52 (52 lbs/hr.)

Velocity® LS1/LS2/LS6/Ford Coyote 5.0L High-Flow Fuel Injector

81050-61 (61 lbs/hr.)

Velocity® LS1/LS2/LS6/Ford Coyote 5.0L High-Flow Fuel Injector

81050-80 (80 lbs/hr.)

Velocity® LS1/LS2/LS6/Ford Coyote 5.0L High-Flow Fuel Injector

81051-52 (52 lbs/hr.)

Velocity® LS3/LS7 High-Flow Fuel Injector

81051-80 (80 lbs/hr.)

Velocity® LS3/LS7 High-Flow Fuel Injector



81050-36

Velocity® LS1/LS2/LS6/Ford Coyote 5.0L High-Flow Fuel Injector, 36 lbs/hr.



81051-52

Velocity® LS3/LS7 High-Flow Fuel Injector, 52lbs/hr



INDUCTION KIT NAME	DESCRIPTION
VL01	LS1/LS2/LS6 Low Profile Angled Velocity® Intake Manifold Kit
VL02	LS1/LS2/LS6 Low Profile Straight Velocity® Intake Manifold Kit
VL02T	LS1/LS2/LS6 High Ram Straight Velocity® Intake Manifold Kit
VL03	LS3 Low Profile Angled Velocity® Intake Manifold Kit
VL03T	LS3 High Ram Straight Velocity® Intake Manifold Kit
VL07	LS7 Low Profile Angled Velocity® Intake Manifold Kit
VL50	Ford Coyote 5.0L High Ram Angled Velocity® Intake Manifold Kit

VELOCITY[®] BY TSP

INDUCTION KITS

VELOCITY[®]



Take care of the whole top end in one shot. Combining all of TSP's high-performance Velocity[®] products, all kits include a fabricated intake manifold and billet aluminum high-pressure fuel rails. Additional options include high-flow fuel injectors and a large-bore throttle body. Kits are available in black and clear anodized.

LS PRODUCTS



81074
LS Retro Fit Oil Pan

LS engines are among the most popular for swaps for their low expense and great power potential. Unfortunately, stock LS oil pans can't always fit where you want them to. That's where TSP's retro fit oil pan comes in. Composed of lightweight cast aluminum, it is designed to allow for increased clearance to the ground and chassis. It will fit many GM rear-wheel drive applications originally equipped with a small or big block Chevy engine and factory rear sump pan. Meticulously designed, it will mount perfectly to any wet-sump LS engine and take the stock oil filter.



JM8081-5

BK P CA

GM LS Fabricated Valve Cover
Center Bolt w/o Coil Mounts



JM8081-6

BK P CA

GM LS Fabricated Valve Cover
Center Bolt w/ Coil Mounts

JM8081-5

GM LS Aluminum Fabricated Valve Cover, Center Bolt without Coil Mounts, Oil Filler Hole
Black, Polished, Clear Anodized

JM8081-6

GM LS Aluminum Fabricated Valve Cover, Center Bolt with Coil Mounts, Oil Filler Hole
Black, Polished, Clear Anodized

JM8081-7

GM LS Aluminum Fabricated Coil Cover, Center Bolt with Billet Oil Filler Neck, Patent # D735759
Black, Polished, Clear Anodized



JM8081-7

BK P CA

GM LS Fabricated Coil Cover Center Bolt w/ Oil Filler Neck, Patent # D735759



81006*

GM LSX Oil Pan Gasket, Neoprene

81006*

GM LSX Oil Pan Gasket, Neoprene
- Will not fit LS7 and LS9 series engines

81004-R

GM LS1/LS2/LS3/LS6 Aluminum Fabricated Oil Pan, Rear Sump, 7-QT
Clear Anodized, Black, Polished

81004-F

GM LS1/LS2/LS3/LS6 Aluminum Fabricated Oil Pan, Front Sump, 7-QT
Clear Anodized, Black, Polished

81017

GM LS1/LS2/LS3/LS6 Oil Pan Pickup, Front Sump

81018

GM LS1/LS2/LS3/LS6 Oil Pan Pickup, Rear Sump



81004-CA-R | 81004-BK-R | 81004-P-R

GM LS1/LS2/LS3/LS6 Aluminum Fabricated Oil Pan, Rear Sump



81004-CA-F | 81004-BK-F | 81004-P-F

GM LS1/LS2/LS3/LS6 Aluminum Fabricated Oil Pan, Front Sump

LS OIL PAN DIMENSIONS: REFER TO PAGE 149



81017

GM LS1/LS2/LS3/LS6 Oil Pan Pickup
Front Sump



81018

GM LS1/LS2/LS3/LS6 Oil Pan Pickup
Rear Sump

*** OEM Replacement**

81013

GM LSX Throttle Cable Steel Bracket,
105mm
Silver, Black

81019

Billet Aluminum Oil Filter Relocation Kit
Black

81031

LS1 Fly by Cable Harness

81033

LS1 to LS3 Map Sensor Adapter

81034

LS3 Map Sensor Extension Harness

81045

GM LS1/LS2/LS6 Valley Cover
Black, Polished

81047

GM LS1/LS2/LS6 Engine Valley Cover
Gasket

81071

Oil Baffle Kit for LS Low Profile Retro Fit
Oil Pan

81072

Oil Baffle Kit for LS Retro Fit Oil Pan

81073

LS Low Profile Retro Fit Oil Pan
Black, Satin, Polished

81074

LS Retro Fit Oil Pan
Black, Satin, Polished

81097

-8AN Male Push on EFI Fitting

81098

Quick Disconnect Female EFI Adapter
Fitting -8AN

81099

GM LS1/LS2/LS3/LS6 Engine Oil Pump
Pickup Tube Girdle
Black, Polished



**6 Ft. Hose Included*

81019

BK

Billet Aluminum Oil Filter Relocation Kit

81033

LS1 to LS3 Map Sensor Adapter



81034

LS3 Map Sensor Extension Harness



81045

GM LS1/LS6 Valley Cover



81072

Oil Baffle Kit for LS Retro Fit Oil Pan



81073

BK S P

LS Low Profile Retro Fit Oil Pan



81074

BK S P

LS Retro Fit Oil Pan



81099

BK P

GM LS1/LS2/LS3/LS6 Engine
Oil Pump Pickup Tube Girdle

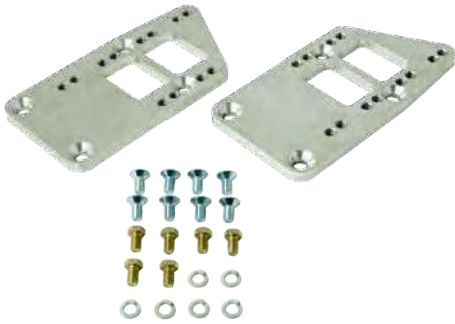

81100

BK N

GM LSX to Chevy SB Motor Mount Adapter Plates

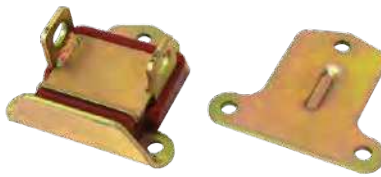

81101

Chevy SB/BB Polyurethane Motor Mount, 1 unit



81102

BK

TSP LSX SFI Certified Harmonic Balancer Steel Damper



81150

BK N

LS to Fox Body Mustang Adapter Plates

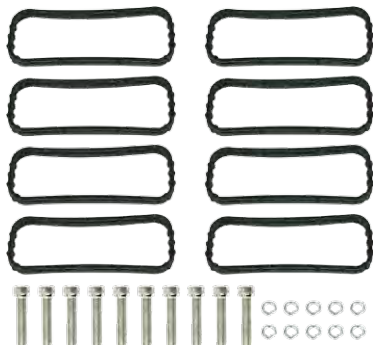

81701

81001/81002 Replacement Gaskets and Mounting Bolts



81708

Fuel Rail Mounting Brackets for 81008



HC8934*

S

GM LS1/LS2/LS6 Car Aluminum Mechanical Water Pump



HC8935*

S

GM LSX Truck 4.8L/5.3L/6.0L Aluminum Mechanical Water Pump

81100

GM LSX to Chevy SB Motor Mount Adapter Plates, Brushed Billet Aluminum Black, Natural

81101

Chevy SB/BB Polyurethane Motor Mount, 1 unit Red/Zinc

81102

TSP LSX SFI Certified Harmonic Balancer Steel Damper, 360° Markings Black

81150

LS to Fox Body Mustang Adapter Plates Black, Natural

81701

81001/81002 Replacement Gaskets and Mounting Bolts

81703

81003 Replacement Gaskets and Mounting Bolts

81707

81007 Replacement Gaskets and Mounting Bolts

81708

Fuel Rail Mounting Brackets for 81008

81709

Fuel Rail Mounting Brackets for 81009

81711

Fuel Rail Mounting Brackets for 81011

HC8934*

GM Car LS1/LS2/LS6, Aluminum Mechanical Water Pump Fits 1997-2006, OEM Replacement Satin

HC8935*

GM LSX Truck 4.8L/5.3L/6.0L, Aluminum Mechanical Water Pump Fits 1999-2006, OEM Replacement Satin

* OEM Replacement

HC8937

LS 45° Aluminum Water Neck
360° Swivel
Black, Chrome

HC8938

LSX Straight Aluminum Water Neck
Black, Chrome

HC8939

LSX -12AN Fitting Water Neck and
Water Pump Adapter

ES1024

GM LS Truck AD244 Alternator,
220 AMP, Serpentine Belt,
4 Pin Connector
Black, Chrome

ES1025

GM LS Car CS130D Alternator,
180 AMP, Serpentine Belt,
4 Pin Connector
Black, Chrome

JM7002

GM LSX 3HP High Torque Starter,
Tilton Style
Red, Black, Chrome

JM7009

GM LSX 1.9HP Starter, Denso Style
Red, Black, All Black



HC8937

BK CH

LS 45° Aluminum Water Neck,
360° Swivel



HC8938

BK CH

LS Straight Aluminum Water Neck



ES1024

BK CH

GM LS Truck AD244 Alternator,
Serpentine Belt, 220 AMP



ES1025

BK CH

GM LS Car CS130D Alternator
Serpentine Belt, 180 AMP



JM7002

R BK CH

GM LSX 3HP High Torque Starter,
Tilton Style



JM7009

R BK A/BK

GM LSX 1.9HP Starter, Denso Style

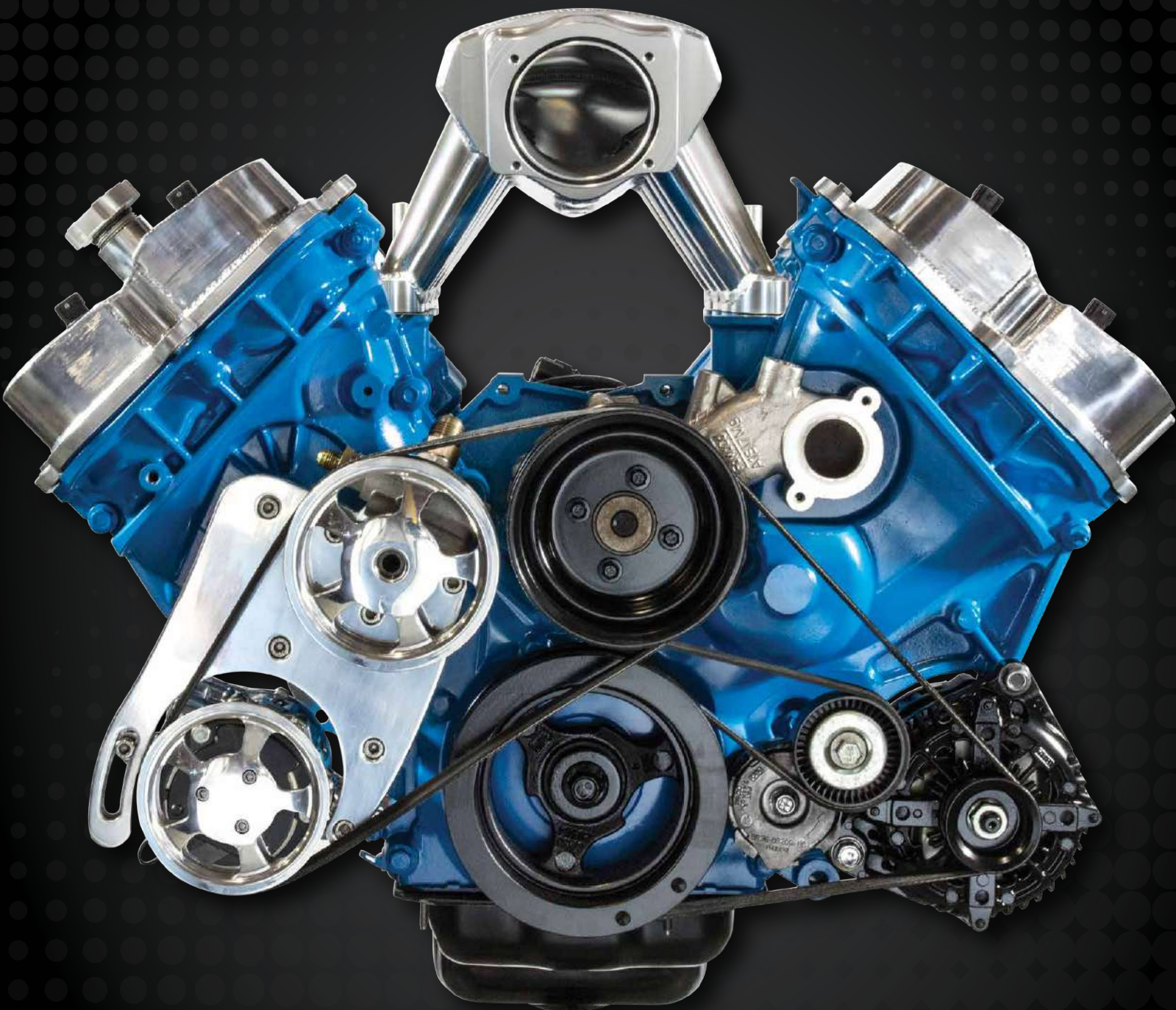

LS COIL RELOCATION KIT



- **81015** : GM LS2/LS3/LS7/LS9 Car Performance Ignition Coil
- **81020** : GM LSX Aluminum Remote Ignition Coil Mounting Bracket

TSP's LS Coil Relocation Kit is a great way to move those unsightly LS coils off of the valve covers. Anyone who's tried to beautify an LS engine knows that step one is hiding or relocating the ignition coils, and this kit does just that. It has been designed to fit two of the most common LSX coils. Constructed from lightweight aluminum, this bracket allows for easy mounting.

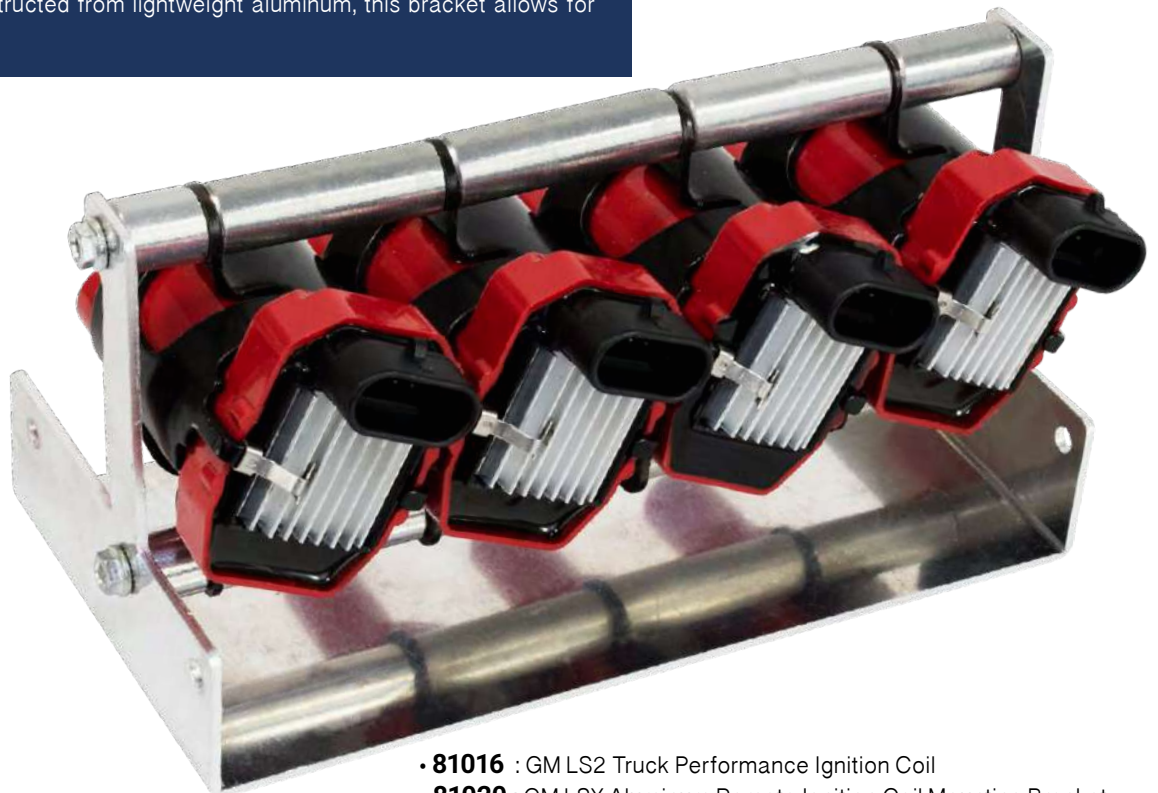

- **81016** : GM LS2 Truck Performance Ignition Coil
- **81020** : GM LSX Aluminum Remote Ignition Coil Mounting Bracket



81015

R

GM LS2/LS3/LS7/LS9 Car Performance Ignition Coil



81016

R

GM LS2 Truck Performance Ignition Coil



81021

GM LSX Ignition Coil Extension Cable 24" length



81024

GM LSX Ignition Coil Relocation Harness, 12" length

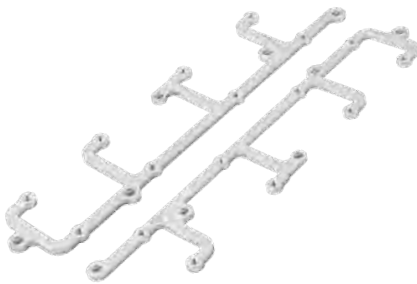

81005

N

GM LS1/LS6 Billet Aluminum Ignition Coil Mounting Bracket



81022

BK N

GM LSX Car Billet Aluminum Ignition Coil Mounting Bracket



81023

BK N

GM LSX Truck Billet Aluminum Ignition Coil Mounting Bracket



81020

BK N

GM LSX Aluminum Remote Ignition Coil Mounting Bracket

TSP LS COILS

- Magnetic steel cores specially designed to deliver 15% more spark than stock
- Shock and vibration resistant epoxy able to tolerate high temperatures
- Optimized winding
- Direct OEM replacement

81015

GM LS2/LS3/LS7/LS9 Car Performance Ignition Coil Red

81015-8

GM LS2/LS3/LS7/LS9 Car Performance Ignition Coils - 8pc/Set Red

81016

GM LS2 Truck Performance Ignition Coil Red

81016-8

GM LS2 Truck Performance Ignition Coils - 8pc/Set Red

81021

GM LSX Ignition Coil Extension Cable 24" length

81024

GM LSX Ignition Coil Relocation Harness 12" length

81005

GM LS1/LS6 Billet Aluminum Ignition Coil Mounting Bracket Natural

81022

GM LSX Car Billet Aluminum Ignition Coil Mounting Bracket Black, Natural

81023

GM LSX Truck Billet Aluminum Ignition Coil Mounting Bracket Black, Natural

81020

GM LSX Aluminum Remote Ignition Coil Mounting Bracket Black, Natural

PRO SERIES PRO BILLET DISTRIBUTORS



Fully adjustable mechanical advance



Ball bearing supported shaft for stability up to 10,000 RPM



Adjustable collar for decked blocks*
**Chevy Only*



Precision CNC machined body



JM7601
Chevy SB/BB V8 Engine
Pro Series Pro Billet Distributor

INSTALLATION: REFER TO PAGE 139

TSP's Pro Series Pro Billet Distributor is for the racer who needs added spark and precision for their high performance power plant. It features a high quality, fully adjustable mechanical advance and an accurate magnetic pickup trigger. The CNC-machined aluminum body and hardened steel shaft, guided by a sealed ball bearing on top and a sintered steel bushing on the bottom, ensure stability up to 10,000 RPM. The dielectric cap features bolt-down and twist-lock capabilities. It has solid brass terminals and comes with a color-matched wire retainer.

Requires a capacitive discharge ignition (CDI) system (See Page 45-46)



JM7601-1* R BK
Chevy SB/BB with Vacuum Advance



JM9601 R BK
Chevy SB/BB Short Cap



JM7602 R BK BL
Ford SB 289/302



JM7603 R BK
Oldsmobile SB/BB



JM7604 R BK
Pontiac SB/BB



JM7606 R BK BL
Ford 351 Cleveland/Ford BB 429-460



JM7608 R BK BL
Ford FE



JM7609 R BK
Chevy 348/409

PRO SERIES PRO BILLET DISTRIBUTORS

Requires a capacitive discharge ignition (CDI) system (Page 45-46)

JM7601*
Chevy SB/BB V8 Engine
Pro Series Pro Billet Distributor
Red, Black

JM7601-1* (with Vacuum Advance)
Chevy SB/BB V8 Engine
Pro Series Pro Billet Distributor with Vacuum Advance
Red, Black

JM9601 (Short Cap)
Chevy SB/BB V8 Engine Short Cap
Pro Series Pro Billet Distributor
Red, Black

JM7602
Ford SB 289/302 V8 Engine
Pro Series Pro Billet Distributor
Red, Black, Blue

JM7603
Oldsmobile SB/BB V8 Engine
Pro Series Pro Billet Distributor
Red, Black

JM7604
Pontiac SB/BB V8 Engine
Pro Series Pro Billet Distributor
Red, Black

JM7606
Ford 351 Cleveland/Ford BB 429-460 V8 Engine Pro Series Pro Billet Distributor
Red, Black, Blue

JM7608
Ford FE V8 Engine Pro Series Pro Billet Distributor
Red, Black, Blue

JM7609
Chevy 348/409 V8 Engine
Pro Series Pro Billet Distributor
Red, Black

*Will not work if it uses a governor

JM7610

Ford 351 Windsor V8 Engine
Pro Series Pro Billet Distributor
Red, Black, Blue

JM7613

Mopar SB 273/318/340/360 V8 Engine
Pro Series Pro Billet Distributor
Red, Black

JM7614**

Mopar BB 413-440, 426 Hemi V8 Engine
Pro Series Pro Billet Distributor
Red, Black

JM7619**

Mopar BB 383/400 V8 Engine
Pro Series Pro Billet Distributor
Red, Black

JM7650

Volkswagen Beetle 1.3
Pro Series Pro Billet Distributor
Red

**** Will not fit fabricated valve covers**

**JM7610**

R BK BL

Ford 351 Windsor

**JM7613**

R BK

Mopar SB 273/318/340/360

**JM7614****

R BK

Mopar BB 413-440, 426 Hemi

**JM7619****

R BK

Mopar BB 383/400

**JM7650**

R

Volkswagen Beetle 1.3

POWER PACK IGNITION KIT

TSP's Power Pack Ignition Kit delivers our best ignition components, all in one retail-friendly display box. It includes our Pro Series Pro Billet distributor, our 50,000 volt E-Core ignition coil, and our 6AL style digital ignition box. This performance ignition kit is perfect for street and strip.



JM7601R
Pro Series Pro Billet Distributor



JM6930R
External E-Core Ignition Coil



JM6931R
Pro Series Digital 6AL Power Box

POWER PACK IGNITION KIT	APPLICATION
JM7901R-KT / JM7901BK-KT	Chevy SB/BB
JM7902R-KT / JM7902BK-KT / JM7902BL-KT	Ford SB 289/302
JM7903R-KT / JM7903BK-KT	Oldsmobile SB/BB
JM7904R-KT / JM7904BK-KT	Pontiac SB/BB
JM7906R-KT / JM7906BK-KT / JM7906BL-KT	Ford 351 Cleveland / Ford BB 429-460
JM7909R-KT / JM7909BK-KT	Chevy 348/409
JM7910R-KT / JM7910BK-KT / JM7910BL-KT	Ford 351 Windsor
JM7913R-KT / JM7913BK-KT	Mopar SB 273/318/340/360
JM7914R-KT / JM7914BK-KT	Mopar BB 413/426/440
JM7919R-KT / JM7919BK-KT	Mopar BB 383/400
JM7950R-KT	Volkswagen Beetle 1.3

PRO SERIES READY TO RUN DISTRIBUTORS



Fully adjustable mechanical advance

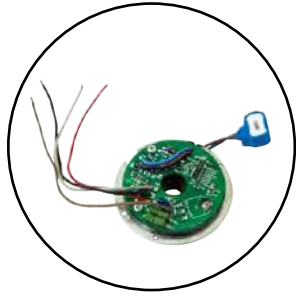

High output circuit board module with digital tach output



Ball bearing supported shaft for stability up to 10,000 RPM



Precision CNC machined body



JM7702
Ford SB 289/302W V8 Engine
Pro Series Ready to Run

INSTALLATION: REFER TO PAGE 139

TSP's Pro Series Ready to Run Distributor is perfect for a street performance upgrade. It features a CNC-machined billet aluminum body and hardened steel shaft, with a sealed ball bearing on top and a sintered steel bushing on the bottom. It also comes with a fully adjustable mechanical advance, vacuum advance, magnetic pickup trigger, and a high-output circuit board module with digital tach output. The dielectric cap comes with solid brass terminals and a color-matched wire retainer.

**JM7701***

R BK BL

Chevy SB/BB - Adjustable Collar

**JM7701-2***

R BK A/BK

Chevy SB/BB - Fixed Collar

**JM7702-5**

R BK BL

Ford SB 302, 5.0L EFI to Carb

**JM7703**

R BK

Oldsmobile SB/BB

**JM7704**

R BK

Pontiac SB/BB

**JM7706**

R BK BL A/BK

Ford 351 Cleveland/Ford BB 429-460

**JM7708**

R BK BL A/BK

Ford FE 352/360/390/427/428

**JM7709**

R BK

Chevy 348-409

PRO SERIES READY TO RUN DISTRIBUTORS

Must connect tach to negative side of the coil if exceeding 6000 RPM, Recommended use JM6930 coil.

JM7701* (Adjustable Collar)

Chevy SB/BB V8 Engine Pro Series Ready to Run Distributor, Adjustable Collar
Red, Black, Blue

JM7701-2* (Fixed Collar)

Chevy SB/BB V8 Engine Pro Series Ready to Run Distributor, Fixed Collar
Red, Black, All Black

JM7702

Ford SB 289/302 V8 Engine Pro Series Ready to Run Distributor
Red, Black, Blue, All Black

JM7702-5

Ford SB 302 V8 Engine, 5.0L EFI to Carb Pro Series Ready to Run Distributor
Red, Black, Blue

JM7703

Oldsmobile SB/BB V8 Engine Pro Series Ready to Run Distributor
Red, Black

JM7704

Pontiac SB/BB V8 Engine Pro Series Ready to Run Distributor
Red, Black

JM7706

Ford 351 Cleveland/Ford BB 429-460 V8 Engine Pro Series Ready to Run Distributor
Red, Black, Blue, All Black

JM7708

Ford FE 352/360/390/427/428 V8 Engine Pro Series Ready to Run Distributor
Red, Black, Blue, All Black

JM7709

Chevy 348-409 V8 Engine Pro Series Ready to Run Distributor
Red, Black

*Will not work if it uses a governor

JM7710

Ford 351 Windsor V8 Engine
Pro Series Ready to Run Distributor
Red, Black, Blue, All Black

JM7711

AMC/Jeep 232-258 I6 Engine
Pro Series Ready to Run Distributor
Red, Black

JM7712

AMC/Jeep 290-401 V8 Engine
Pro Series Ready to Run Distributor
Red, Black

JM7713

Mopar SB 273/318/340/360 V8 Engine
Pro Series Ready to Run Distributor
Red, Black

JM7714**

Mopar BB 413-440, 426 Hemi V8 Engine
Pro Series Ready to Run Distributor
Red, Black

JM7715

1962-1974 Chevy Corvette SB/BB
Tach Drive V8 Engine
Pro Series Ready to Run Distributor
Red, Black

JM7716

1941-1962 Early Chevy 194/216/235,
1968-1987 Toyota Land Cruiser F 2F,
I6 Engine Pro Series Ready to Run
Distributor
Red, Black

JM7717

Cadillac 472/500 V8 Engine
Pro Series Ready to Run Distributor
Red, Black

****Will not fit fabricated valve covers**

**JM7710**

Ford 351 Windsor

**JM7711**

AMC/Jeep 232-258

**JM7712**

AMC/Jeep 290-401

**JM7713**

Mopar SB 273/318/340/360

**JM7714****

Mopar BB 413-440, 426 Hemi

**JM7715**

1962-1974 Chevy Corvette SB/BB
Tach Drive

**JM7716**

1941-1962 Early Chevy 194/216/235
1968-1987 Toyota Land Cruiser F 2F

**JM7717**

Cadillac 472/500

**JM7719****

Mopar BB 383/400

R BK

**JM7721**

Chevy V6 Engine

R BK

**JM7723**

Chevy 230/250/292

R BK

**JM7724**

Buick SB

R BK

**JM7725**

Buick BB

R BK

**JM7727**

Ford 170/200/250

R BK BL

**JM7728**

Ford 240/300

R BK BL

**JM7730**

Early Hemi Mopar 392

R BK

JM7719**

Mopar BB 383/400 V8 Engine
Pro Series Ready to Run Distributor
Red, Black

JM7721

Chevy V6 Engine Pro Series
Ready to Run Distributor
Red, Black

JM7723

Chevy 230/250/292 I6 Engine
Pro Series Ready to Run Distributor
Red, Black

JM7724

Buick SB V8 Engine Pro Series
Ready to Run Distributor
Red, Black

JM7725

Buick BB V8 Engine Pro Series
Ready to Run Distributor
Red, Black

JM7727

Ford 170/200/250 I6 Engine 5/16 Hex Shaft
Pro Series Ready to Run Distributor
Red, Black, Blue

JM7728

Ford 240/300 I6 Engine
Pro Series Ready to Run Distributor
Red, Black, Blue

JM7730

Early Hemi Mopar 392 Engine
Pro Series Ready to Run Distributor
Red, Black

****Will not fit fabricated valve covers**

JM7731

Early Hemi Mopar 331/354 Engine
Pro Series Ready to Run Distributor
Red, Black

JM7732

Chevy Corvair Flat 6 Engine
Pro Series Ready to Run Distributor
Red, Black

JM7733

1951-1964 Studebaker V8 Engine
Pro Series Ready to Run Distributor
Red, Black

JM7735

Buick Nailhead 322-425 V8 Engine
Pro Series Ready to Run Distributor
Red, Black

JM7740

1949-1953 Ford Flathead V8 Engine
Pro Series Ready to Run Distributor
Red, Black, Blue

JM7742

Ford 272/292/312 Y-Block Engine
Pro Series Ready to Run Distributor
Red, Black, Blue

JM7750

Volkswagen Beetle 1.3
Pro Series Ready to Run Distributor
Red, Black, Blue

**JM7731**

R BK

Early Hemi Mopar 331/354

**JM7732**

R BK

Chevy Corvair

**JM7733**

R BK

Studebaker

**JM7735**

R BK

Buick Nailhead 322-425

**JM7740**

R BK BL

Ford Flathead

**JM7742**

R BK BL

Ford 272/292/312

**JM7750**

R BK

Volkswagen Beetle 1.3

PRO SERIES

READY TO RUN KIT

TSP's Pro Series Ready to Run Kit is perfect for firing up your street performance machine. It's available for many applications and comes with our Pro Series Ready to Run distributor and one of our new 45,000 volt oil-filled canister ignition coils.

- JM8801R-KT / JM8801BK-KT / JM8801BL-KT : Chevy SB/BB
- JM8802-5R-KT / JM8802-5BK-KT / JM8802-5BL-KT : Ford SB 302, 5.0L EFI to Carb
- JM8803R-KT / JM8803BK-KT : Oldsmobile SB/BB
- JM8804R-KT / JM8804BK-KT : Pontiac SB/BB
- JM8806R-KT / JM8806BK-KT / JM8806BL-KT : Ford 351 Cleveland/Ford BB 429-460
- JM8808R-KT / JM8808BK-KT / JM8808BL-KT : Ford FE 352/360/390/427/428
- JM8809R-KT / JM8809BK-KT : Chevy 348-409
- JM8810R-KT / JM8810BK-KT / JM8810BL-KT : Ford 351 Windsor
- JM8811R-KT / JM8811BK-KT : AMC/Jeep 232-258
- JM8812R-KT / JM8812BK-KT : AMC/Jeep 290-401
- JM8813R-KT / JM8813BK-KT : Mopar SB 273/318/340/360
- JM8814R-KT / JM8814BK-KT : Mopar BB 413/426/440
- JM8815R-KT / JM8815BK-KT : Chevy Corvette SB/BB
- JM8816R-KT / JM8816BK-KT : 1941-1962 Early Chevy 194/216/235
- JM8817R-KT / JM8817BK-KT : Cadillac 472/500
- JM8819R-KT / JM8819BK-KT : Mopar BB 383/400
- JM8821R-KT / JM8821BK-KT : Chevy V6
- JM8823R-KT / JM8823BK-KT : Chevy 230/250/292
- JM8824R-KT / JM8824BK-KT : Buick SB
- JM8825R-KT / JM8825BK-KT : Buick BB
- JM8827R-KT / JM8827BK-KT / JM8827BL-KT : Ford 144/200/250
- JM8828R-KT / JM8828BK-KT : Ford 240/300
- JM8832R-KT / JM8832BK-KT : Chevy Corvair
- JM8833R-KT / JM8833BK-KT : 1951-1964 Studebaker
- JM8835R-KT / JM8835BK-KT : Buick Nailhead 322-425
- JM8840R-KT / JM8840BK-KT : 1949-1953 Ford Flathead
- JM8842R-KT / JM8842BK-KT / JM8842BL-KT : Ford 272/292/312
- JM8850R-KT / JM8850BK-KT : Volkswagen Beetle 1.3



TSP
TOP STREET PERFORMANCE

HEI DISTRIBUTORS



Mechanical advance



High output HEI 4 pin module



1 wire hookup

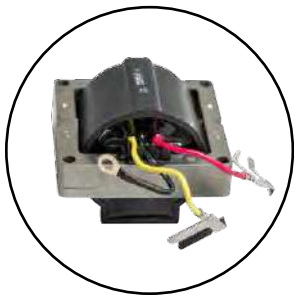

65K Volt Coil

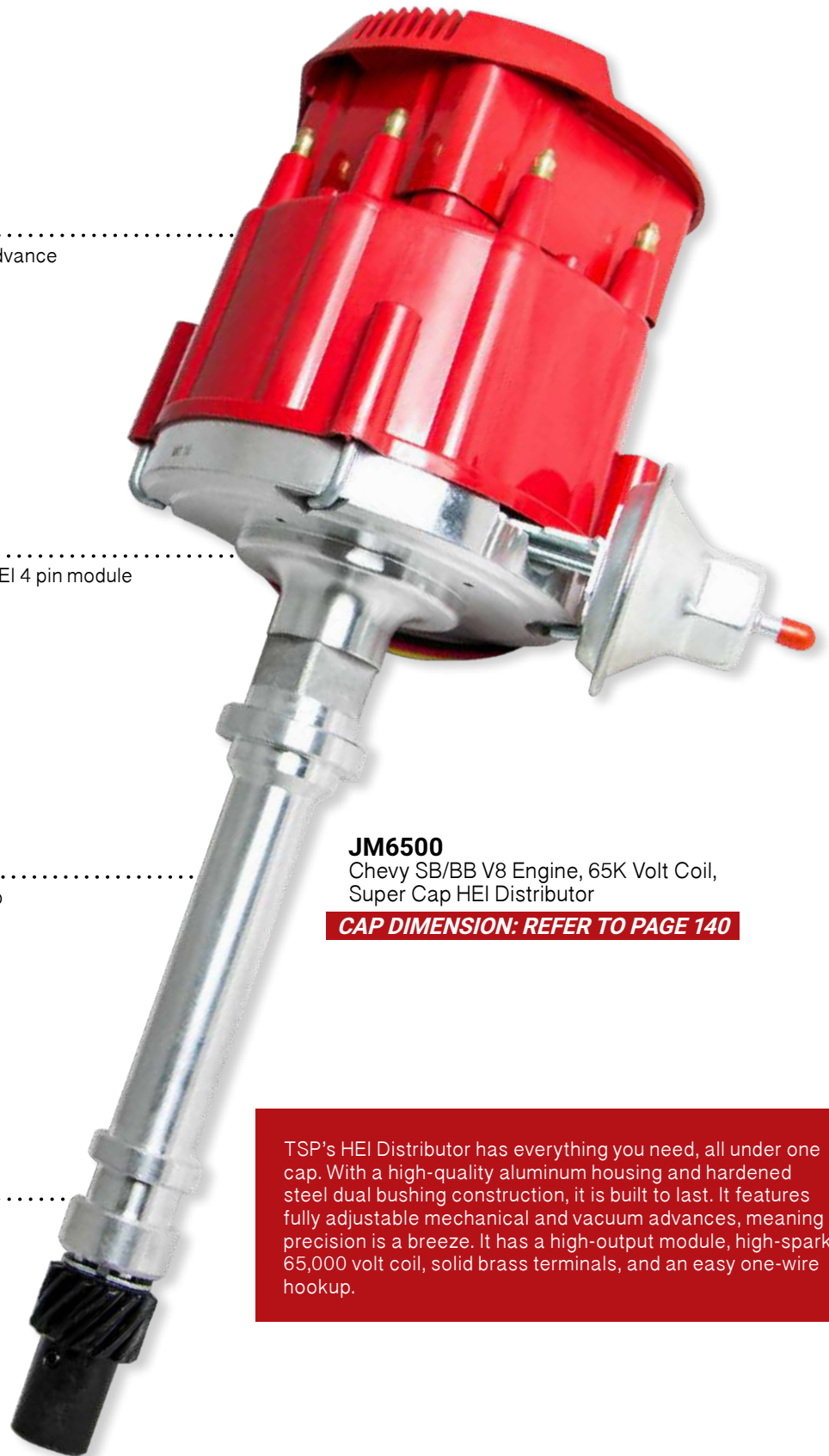

JM6500

Chevy SB/BB V8 Engine, 65K Volt Coil, Super Cap HEI Distributor

CAP DIMENSION: REFER TO PAGE 140

TSP's HEI Distributor has everything you need, all under one cap. With a high-quality aluminum housing and hardened steel dual bushing construction, it is built to last. It features fully adjustable mechanical and vacuum advances, meaning precision is a breeze. It has a high-output module, high-spark 65,000 volt coil, solid brass terminals, and an easy one-wire hookup.



JM6501* R BK CL BL R BK A/BK
Chevy SB/BB - OEM Cap



JM6502 R BK CL BL A/BK
Ford SB 289/302



JM6502-5 R BK BL
Ford SB 302, 5.0L EFI to Carb



JM6503 R BK CL BL
Oldsmobile SB/BB



JM6504 R BK CL BL
Pontiac SB/BB



JM6506 R BK CL BL OR A/BK
Ford 351 Cleveland/Ford BB 429-460



JM6508 R BK CL BL A/BK
Ford FE 352/360/390/427/428



JM6508-5 R BK
Ford FE 330/361/391

HEI DISTRIBUTORS

JM6500*

Chevy SB/BB V8 Engine, 65K Volt Coil HEI Distributor, Super Cap
Red, Black, Clear, Grey

JM6501*

Chevy SB/BB V8 Engine, 65K Volt Coil HEI Distributor, OEM Cap
Red, Black, Clear, Blue, Red/Black, All Black

JM6502

Ford SB 289/302 V8 Engine, 65K Volt Coil HEI Distributor
Red, Black, Clear, Blue, All Black

JM6502-5

Ford SB 302 V8 Engine, 5.0L EFI to Carb, 65K Volt Coil HEI Distributor
Red, Black, Blue

JM6503

Oldsmobile SB/BB V8 Engine, 65K Volt Coil HEI Distributor
Red, Black, Clear, Blue

JM6504

Pontiac SB/BB V8 Engine, 65K Volt Coil HEI Distributor
Red, Black, Clear, Blue

JM6506

Ford 351 Cleveland/Ford BB 429-460 V8 Engine, 65K Volt Coil HEI Distributor
Red, Black, Clear, Blue, Orange, All Black

JM6508

Ford FE 352/360/390/427/428 V8 Engine, 65K Volt Coil HEI Distributor with 1/4 Shaft
Red, Black, Clear, Blue, All Black

JM6508-5

Ford FE 330/361/391 V8 Engine, 65K Volt Coil Heavy-Duty Truck with 5/16 Shaft
Red, Black

***Will not work if it uses a governor**

JM6509

Chevy 348/409 V8 Engine,
65K Volt Coil HEI Distributor
Red, Black

JM6510

Ford 351 Windsor V8 Engine,
65K Volt Coil HEI Distributor
Red, Black, Clear, Blue, All Black

JM6511

AMC/Jeep 232/258 I6 Engine,
65K Volt Coil HEI Distributor
Red, Black, Clear, Blue

JM6512

AMC/Jeep 290-401 V8 Engine,
65K Volt Coil HEI Distributor
Red, Black, Clear, Blue

JM6513

Mopar SB 273/318/340/360 V8 Engine,
65K Volt Coil HEI Distributor
Red, Black, Blue, Orange

JM6515

1962-1974 Chevy Corvette SB/BB
Tach Drive V8 Engine, 65K Volt Coil
HEI Distributor
Red, Black, Clear, Blue

JM6516

1941-1962 Early Chevy 194/216/235,
1968-1987 Toyota Land Cruiser F 2F,
I6 Engine, 65K Volt Coil HEI Distributor
Red, Black, Clear

JM6517

Cadillac 472/500 V8 Engine,
65K Volt Coil HEI Distributor
Red, Black



JM6509

Chevy 348/409



JM6510

Ford 351 Windsor



JM6511

AMC/Jeep 232/258



JM6512

AMC/Jeep 290-401



JM6513

Mopar SB 273/318/340/360



JM6515

1962-1974 Chevy Corvette SB/BB
Tach Drive



JM6516

1941-1962 Early Chevy 194/216/235
1968-1987 Toyota Land Cruiser F 2F



JM6517

Cadillac 472/500



**JM6520**

R BK

Chevy V6 Engine - Super Cap

**JM6521**

R BK BL

Chevy V6 Engine - OEM Cap

**JM6522**

R BK

Chevy 230/250/292 - Super Cap

**JM6523**

R BK

Chevy 230/250/292 - OEM Cap

**JM6524**

R BK CL BL

Buick SB

**JM6525**

R BK CL BL

Buick BB

**JM6526**

R BK CL BL

Buick Even Fire

**JM6527**

R BK CL BL

Ford 170/200/250

JM6520Chevy V6 Engine, 65K Volt Coil
HEI Distributor, Super Cap
Red, Black**JM6521**Chevy V6 Engine, 65K Volt Coil
HEI Distributor, OEM Cap
Red, Black, Blue**JM6522**Chevy 230/250/292 I6 Engine,
65K Volt Coil HEI Distributor, Super Cap
Red, Black**JM6523**Chevy 230/250/292 I6 Engine,
65K Volt Coil HEI Distributor, OEM Cap
Red, Black**JM6524**Buick SB V8 Engine, 65K Volt Coil
HEI Distributor
Red, Black, Clear, Blue
*- Will not fit Buick SB 300***JM6525**Buick BB V8 Engine, 65K Volt Coil
HEI Distributor
Red, Black, Clear, Blue**JM6526**Buick Even Fire V6 Engine, 65K Volt Coil
HEI Distributor
Red, Black, Clear, Blue**JM6527**Ford 170/200/250 I6 Engine, 65K Volt Coil,
5/16 Hex Shaft HEI Distributor
Red, Black, Clear, Blue

JM6528

Ford 240/300 I6 Engine, 65K Volt Coil
HEI Distributor
Red, Black, Blue

JM6529

Buick Odd Fire, 65K Volt Coil
HEI Distributor
Red, Black

JM6530

Early Hemi Mopar 392 Engine,
65K Volt Coil HEI Distributor
Red, Black, Orange

JM6531

Early Hemi Mopar 331/354 Engine,
65K Volt Coil HEI Distributor
Red, Black, Orange

JM6535

Buick Nailhead 322-425 V8 Engine,
65K Volt Coil HEI Distributor
Red, Black



JM6528

Ford 240/300



JM6529

Buick Odd Fire



JM6530

Early Hemi Mopar 392



JM6531

Early Hemi Mopar 331/354



JM6535

Buick Nailhead 322-425





PRO BILLET DISTRIBUTORS

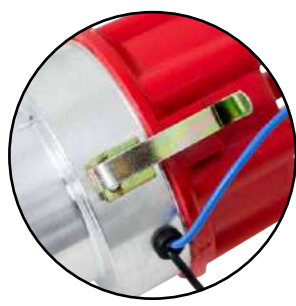

Quick clip-on 208 series cap

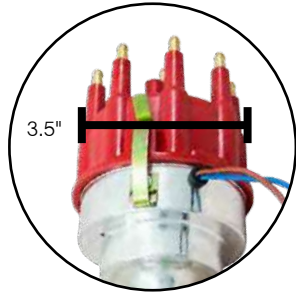

Compact 3.5" diameter design



Ball bearing supported shaft



Hardened steel gears

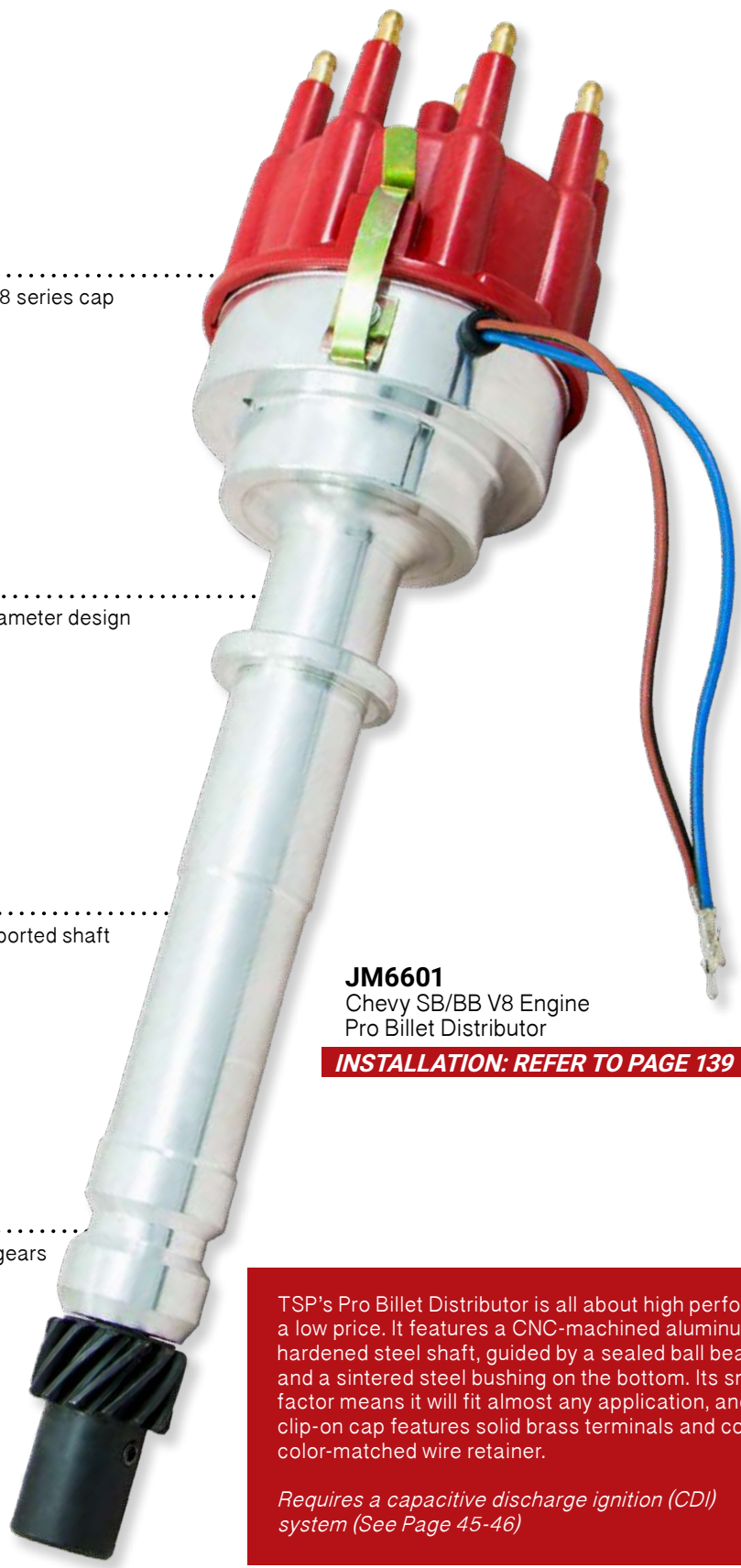

JM6601
Chevy SB/BB V8 Engine
Pro Billet Distributor

INSTALLATION: REFER TO PAGE 139

TSP's Pro Billet Distributor is all about high performance at a low price. It features a CNC-machined aluminum body and hardened steel shaft, guided by a sealed ball bearing on top and a sintered steel bushing on the bottom. Its small form factor means it will fit almost any application, and its quick clip-on cap features solid brass terminals and comes with a color-matched wire retainer.

Requires a capacitive discharge ignition (CDI) system (See Page 45-46)

**JM6602**

Ford SB 289/302

**JM6606**

Ford 351 Cleveland/Ford BB 429-460

**JM6610**

Ford 351 Windsor

**JM6613**

Mopar SB 273/318/340/360

**JM6614**

Mopar BB 413-440, 426 Hemi

**PRO BILLET
DISTRIBUTORS****JM6601***Chevy SB/BB V8 Engine
Pro Billet Distributor
Red, Black**JM6602**Ford SB 289/302 V8 Engine
Pro Billet Distributor
Red, Black, Blue**JM6606**Ford 351 Cleveland/Ford BB 429-460
V8 Engine Pro Billet Distributor
Red, Black, Blue**JM6610**Ford 351 Windsor V8 Engine
Pro Billet Distributor
Red, Black, Blue**JM6613**Mopar SB 273/318/340/360
V8 Engine Pro Billet Distributor
Red, Black, Blue**JM6614**Mopar BB 413-440, 426 Hemi V8 Engine
Pro Billet Distributor
Red, Black, Blue***Will not work if it uses a governor**

READY TO RUN DISTRIBUTORS



Quick clip-on 208 series cap



Ball bearing supported shaft



Easy change module



Compact 3.5" diameter design

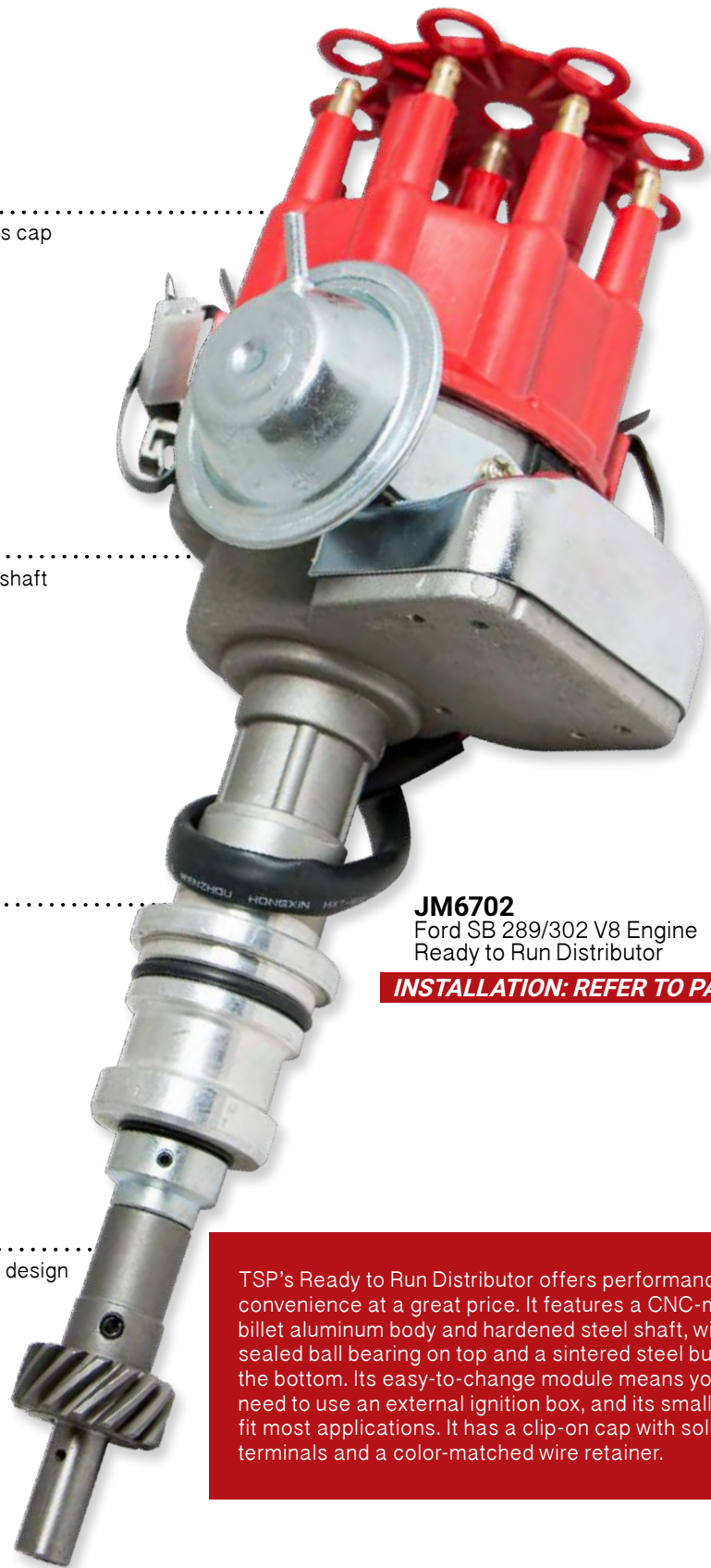

JM6702
Ford SB 289/302 V8 Engine
Ready to Run Distributor

INSTALLATION: REFER TO PAGE 140

TSP's Ready to Run Distributor offers performance and convenience at a great price. It features a CNC-machined billet aluminum body and hardened steel shaft, with a sealed ball bearing on top and a sintered steel bushing on the bottom. Its easy-to-change module means you won't need to use an external ignition box, and its small size will fit most applications. It has a clip-on cap with solid brass terminals and a color-matched wire retainer.

**JM6701***

Chevy SB/BB

**JM6704**

Pontiac SB/BB

**JM6706**

Ford 351 Cleveland/Ford BB 429-460

**JM6710**

Ford 351 Windsor

**JM6713**

Mopar SB 273/318/340/360

**JM6714**

Mopar BB 413-440, 426 Hemi

**READY TO RUN
DISTRIBUTORS****JM6701***Chevy SB/BB V8 Engine
Ready to Run Distributor
Red, Black, Blue**JM6702**Ford SB 289/302 V8 Engine
Ready to Run Distributor
Red, Black, Blue**JM6704**Pontiac SB/BB V8 Engine
Ready to Run Distributor
Red, Black, Blue**JM6706**Ford 351 Cleveland/Ford BB 429-460
V8 Engine Ready to Run Distributor
Red, Black, Blue**JM6710**Ford 351 Windsor V8 Engine
Ready to Run Distributor
Red, Black, Blue**JM6713**Mopar SB 273/318/340/360 V8 Engine
Ready to Run Distributor
Red, Black, Blue**JM6714**Mopar BB 413-440, 426 Hemi V8 Engine
Ready to Run Distributor
Red, Black, Blue***Will not work if it uses a governor**

EFI DISTRIBUTORS



Solid brass terminals



Includes zinc coated steel hold down



Increased strength over stock plastic units with full aluminum construction



JM6672
GM 5.0L/5.7L 1996-2002
V8 Engine Vortec Distributor

TSP's EFI Distributors offer a great alternative to the OEM price. They are designed and constructed to meet or exceed all OEM standards. With cast aluminum bodies and solid brass terminals, these are a no-brainer when replacing an EFI distributor.

**JM6651****R**

GM EFI V6 Engine

**JM6652****R**

GM EFI V8 Engine

**JM6684****R BK BL**

Ford 5.8L/351 V8 Engine

**JM6688****R BK BL**

Ford 5.0L/302 V8 Engine

**JM6505****BK**

Chevy LT1 V8 Engine Gen 1 Optispark

**JM6507****BK**

Chevy LT1 V8 Engine Gen 2 Optispark

**JM6671****BK**

GM 4.3L V6 Engine Vortec

**JM6673****BK**

GM 7.4L V8 Engine Vortec

EFI DISTRIBUTORS

Our EFI distributors are built from high quality materials in order to exceed OEM standards.

JM6651

GM EFI V6 Engine 1985-1996
EFI Distributor
Red

JM6652

GM EFI V8 Engine 1987-1994
EFI Distributor
Red

JM6680

Ford 5.0L/302 V8 Engine 1985-1991
EFI Distributor
Red, Black, Blue

JM6684

Ford 5.8L/351 V8 Engine 1988-1991
EFI Distributor
Red, Black, Blue

JM6688

Ford 5.0L/302 V8 Engine 1991-1995
EFI Distributor
Red, Black, Blue

JM6691

Ford 5.8L/351 V8 Engine 1990-1995
EFI Distributor
Red, Black, Blue

OPTISPARK DISTRIBUTOR**JM6505**

GM LT1 1992-1994 V8 Engine
Gen 1 Optispark Distributor
Black

JM6507

GM LT1 1995-1997 V8 Engine
Gen 2 Optispark Distributor
Black

VORTEC DISTRIBUTOR**JM6671**

GM 4.3L 1996-2007
V6 Engine Vortec Distributor
Black

JM6672

GM 5.0L/5.7L 1996-2002
V8 Engine Vortec Distributor
Black

JM6673

GM 7.4L 1996-2000
V8 Engine Vortec Distributor
Black

IGNITION ACCESSORIES

Top Street Performance's 6AL Power Boxes

use the newest digital circuitry in the industry to provide maximum spark energy with less amp draw. The highly efficient electronics are housed inside a small form factor aluminum case for easy mounting on a firewall or fender of any vehicle.

- Improves spark at start and idle
- Full output at high RPM
- Adjustable Revolution limiter
- Easy connection amplifiers, points, and magnetic pickup

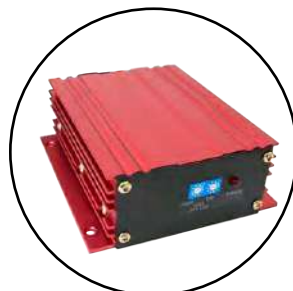

Digital Circuitry

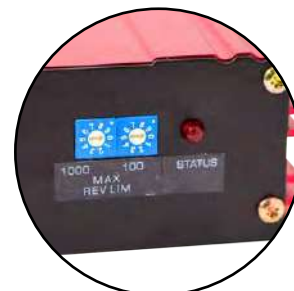

Adjustable Rev. Limiter



JM6939

Mini Digital Power Box

- Spark: 95 MJ
- Primary Voltage: 435V
- Secondary: 45,000 Volts
- Spark Duration: 20° Crankshaft Rotation
- Current Draw: 0.7 AMPS per 1,000 RPM

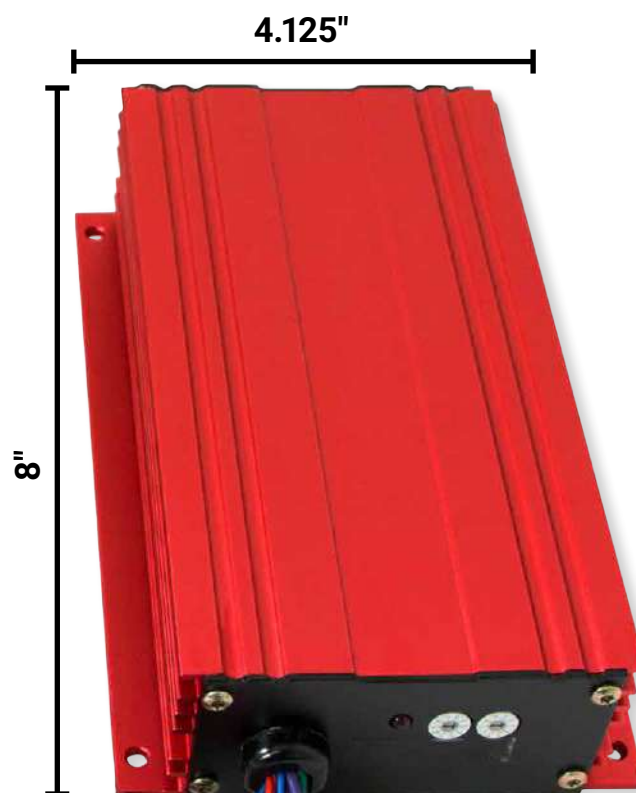

JM6931

Digital Power Box

- Spark: 135-145 MJ
- Primary Voltage: 520-540V
- Secondary: 45,000 Volts
- Spark Duration: 20° Crankshaft Rotation
- Current Draw: 0.7 AMPS per 1,000 RPM

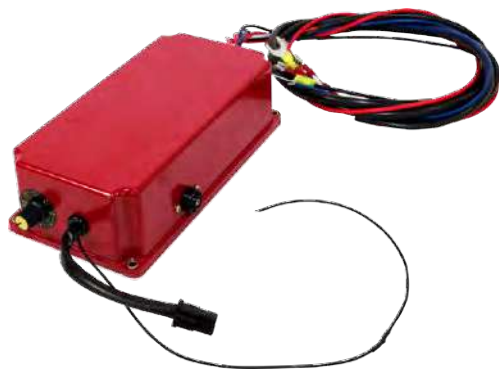
**JM6929**

R BK

6AL Style Ignition Box

**JM6924**

R BK

Compact External E-Core Ignition Coil

**Mounting Bracket Included***JM6927**

R BK BL CH

Canister Round Oil Filled Ignition Coil
Female Socket**Mounting Bracket Included***JM6928**

R BK BL CH

Canister Round Oil Filled Ignition Coil
Male Socket**JM6930**

R BK BL

External E-Core Ignition Coil

**JM6936**

R

GM EFI Dual Connector Ignition Coil

**JM6937**

R

GM DIS Ignition Coil

**JM6938**

R BL

Ford TFI Ignition Coil

IGNITION ACCESSORIES

IGNITION BOXES

With increased spark intensity, the 6AL Power Box will help any engine produce more power, and increase throttle response. They're compatible with points and electronic ignitions. They work with 4, 6, and 8-cylinder engines. It will work best with TSP Pro Series Pro Billet Distributors.

JM6929

6AL Style Ignition Box
Red, Black

JM6931

Digital 6AL Power Box
with Revolution Limiter
Red, Black

JM6939

Mini Digital 6AL Power Box
with Revolution Limiter
Red, Black

IGNITION COILS

JM6910

HEI Ignition Coil, 65K Volt

JM6924

Compact External E-Core Ignition Coil,
40K Volt
Red, Black

JM6927

Canister Round Oil Filled Ignition Coil,
45K Volt, Female Socket,
Mounting Bracket Included
Red, Black, Blue, Chrome

JM6928

Canister Round Oil Filled Ignition Coil,
45K Volt, Male Socket,
Mounting Bracket Included
Red, Black, Blue, Chrome

JM6930

External E-Core Ignition Coil, 50K Volt
Red, Black, Blue

JM6936

GM 1985-1996 EFI Dual Connector
Ignition Coil, 48K Volt
Red

JM6937

GM 1986-2003 DIS Ignition Coil,
48K Volt
Red

JM6938

Ford 1984-1998 TFI Ignition Coil,
48K Volt
Red, Blue

TSP IGNITION COILS

- Magnetic steel cores specially designed to deliver 15% more spark than stock
- Shock and vibration resistant epoxy able to tolerate high temperatures
- Optimized winding
- Direct OEM replacement

JM6802-6

Ford/Mazda/Mercury 2000-2008
V6 Engine Ignition Coil,
35K Volt, 6pc/Set
Blue

JM6804-6

Ford/Mazda/Mercury 2000-2008
V6 Engine Ignition Coil,
35K Volt, 6pc/Set
Blue

JM6807

Ford/Mazda/Mercury 1998-2011
V6 Engine Ignition Coil, 40K Volt,
EDIS Horizontal Harness Connector
Blue

JM6808

Ford/Mazda/Mercury 1989-2000
V6 Engine Ignition Coil, 40K Volt,
EDIS Vertical Harness Connector
Blue

JM6809-8

Ford Coyote 5.0L 2011-2016 V8 Engine
Ignition Coil, 45K Volt, 8pc/Set
Blue

JM6810-6

Ford 2007-2016 V6 Engine
Ignition Coil, 45K Volt, 6pc/Set
Blue

JM6831

GM 1996-2001 Vortec Engine
Ignition Coil, 45K Volt, Single Connector
HEI Remote Mount Coil
Red

JM6840

Acura 1992-2001/Honda 1990-2002
Ignition Coil, 40K Volt, Internal Coil Only
Red



JM6802-6

BL

Ford/Mazda/Mercury Ignition Coil,
6pc/Set



JM6804-6

BL

Ford/Mazda/Mercury Ignition Coil,
6pc/Set

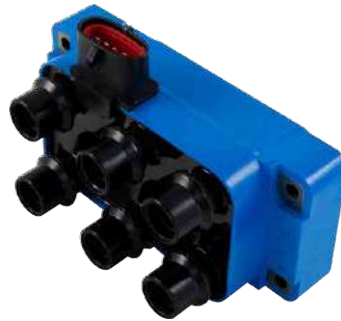

JM6807

BL

Ford/Mazda/Mercury Ignition Coil,
EDIS Horizontal Harness Connector



JM6808

BL

Ford/Mazda/Mercury Ignition Coil,
EDIS Vertical Harness Connector



JM6809-8

BL

Ford Coyote 5.0L Ignition Coil, 8pc/Set



JM6810-6

BL

Ford Ignition Coil, 6pc/Set



JM6831

R

GM Vortec Engine Ignition Coil, Single
Connector HEI Remote Mount Coil



JM6840

R

Acura/Honda Ignition Coil
Internal Coil Only

**JM6852**

Chrysler/Dodge/Jeep/Plymouth
Ignition Coil

R

**JM6853**

Chrysler/Dodge/Jeep/Mini/Mitsubishi/
Plymouth Ignition Coil

R

**JM6945***

Ford 2 Valve Ignition Coil

BL

**JM6945-8***

Ford 2 Valve Ignition Coil, 8pc/Set

BL

**JM6946**

Ford 3 Valve Ignition Coil

BL

**JM6946-8**

Ford 3 Valve Ignition Coil, 8pc/Set

BL

JM6852

Chrysler/Dodge/Jeep/Plymouth
1988-2003 Ignition Coil, 45K Volt
Red

JM6853

Chrysler/Dodge/Jeep/Mini/Mitsubishi/
Plymouth 1997-2003 Ignition Coil,
40K Volt
Red

JM6945*

Ford 1997-2014 SOHC 4.6L/5.4L/6.8L
V8 Engine, 2 Valve Ignition Coil
Blue

JM6945-8*

Ford 1997-2014 SOHC 4.6L/5.4L/6.8L
V8 Engine, 2 Valve Ignition Coil
8 pc/Set - Blue

**Will not fit 2004 and newer F150 with 5.4L
V8 Engine. Use JM6946 for these models.*

JM6946

Ford 2004-2008 SOHC 4.6L/5.4L/6.8L
V8 Engine, 3 Valve Ignition Coil
Blue

JM6946-8

Ford 2004-2008 SOHC 4.6L/5.4L/6.8L
V8 Engine, 3 Valve Ignition Coil
8pc/Set - Blue

IGNITION ACCESSORIES**JM6505CB**

Chevy 1992-1994 Optispark
Wire Harness Cable

JM6507CB

Chevy 1995-1997 Optispark
Wire Harness Cable

**JM6505CB**

Chevy 1992-1994 Optispark Wire
Harness Cable

**JM6507CB**

Chevy 1995-1997 Optispark Wire
Harness Cable

JM6500CB

HEI Distributor Power & Tachometer Pigtail Harness, 2-Piece

JM6933

HEI Distributor Power & Tachometer Pigtail Harness, 1-Piece

JM6930PT

Ignition Coil Wire Harness for JM6930

JM6934

HEI Distributor Module Bypass Harness for 6AL Ignition Box

JM6902

HEI Distributor Replacement Wiring Harness with Capacitor

JM6903

HEI Distributor OEM Coil Cover, 6 Cylinder
Black, Clear, Red

JM6904

HEI Distributor Cap Only, 8 Cylinder
Black, Blue, Clear, Red

JM6905

HEI Distributor OEM Cap Hardware Kit

JM6906

HEI Distributor Super Coil Cover
Black, Clear, Gray, Red



JM6500CB

HEI Distributor Power & Tachometer Pigtail Harness, 2-Piece



JM6933

HEI Distributor Power & Tachometer Pigtail Harness, 1-Piece



JM6930PT

Ignition Coil Wire Harness



JM6934

HEI Distributor Module Bypass Harness



JM6902

HEI Distributor Replacement Wiring Harness with Capacitor



JM6904

HEI Distributor Cap Only, 8 Cylinder



JM6905

HEI Distributor OEM Cap Hardware Kit



JM6906

HEI Distributor Super Coil Cover



**JM6907**

BK BL R

HEI Distributor OEM Coil Cover,
8 Cylinder**JM6908**

BK BL R

HEI Distributor OEM Cap Wire Retainer

**JM6913**HEI Vacuum Advance Reverse
Rotation Lockout, Steel**JM6914**

HEI Vacuum Advance Lockout, Steel

**JM6915**

HEI Distributor Fully Adjustable Vacuum

**JM6916**

BK BL CL R

HEI Distributor Rotor

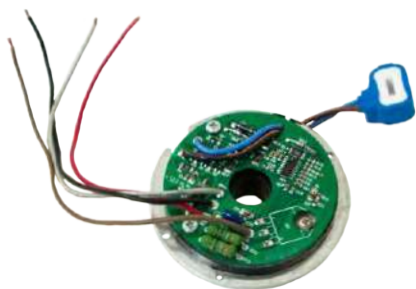
**JM6918**Pro Series Ready to Run Distributor
Circuit Board Module**JM6919**

Pro Series Distributor Magnetic Pick-Up

JM6907HEI Distributor OEM Coil Cover,
8 Cylinder
Black, Blue, Red**JM6908**HEI Distributor OEM Cap Wire Retainer
Black, Blue, Red**JM6913**HEI Vacuum Advance Reverse Rotation
Lockout, Steel**JM6914**

HEI Vacuum Advance Lockout, Steel

JM6915HEI Distributor Fully Adjustable Vacuum
Advance**JM6916**HEI Distributor Rotor
Black, Blue, Clear, Red**JM6918**Pro Series Ready to Run Distributor
Circuit Board Module**JM6919**

Pro Series Distributor Magnetic Pick-Up

JM6925

HEI Distributor V8 Engine Pick-Up Coil

JM6926Chevy HEI Distributor Hold Down
Clamp V6 & V8 Engine
Black, Blue, Silver, Red**JM6917**HEI Distributor 4-Pin Module
For 65XX Series**JM6932**Ready to Run Ignition Module
For 67XX Series**JM6941**Optispark Distributor Module/Optical
Sensor (JM6505), 1992-1994**JM6942**Optispark Distributor Module/Optical
Sensor (JM6507), 1995-1997**JM6943**

GM EFI Distributor Module

JM6944

GM Vortec Distributor Module

**JM6925**HEI Distributor Pick-Up Coil
V8 Engine**JM6926**Chevy HEI Distributor Hold Down
Clamp V6 & V8 Engine**JM6917**HEI Distributor 4-Pin Module
For 65XX Series**JM6932**Ready to Run Ignition Module
For 67XX Series**JM6941**Optispark Distributor Module/Optical
Sensor, 1992-1994**JM6942**Optispark Distributor Module/Optical
Sensor, 1995-1997**JM6943**

GM EFI Distributor Module

**JM6944**

GM Vortec Distributor Module



JM6950 **BK** **BL** **CL** **GY** **R**
HEI Distributor Super Cap Kit, V8 Engine

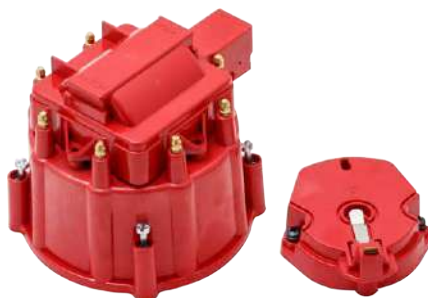

JM6951 **BK** **BL** **CL** **OR** **R**
HEI Distributor OEM Cap Kit, V8 Engine



JM6952 **BK** **CL** **R**
HEI Distributor Super Cap Kit, 6 Cylinder



JM6953 **BK** **BL** **CL** **R**
HEI Distributor OEM Cap Kit, 6 Cylinder



JM6971 **BK** **BL** **R**
Pro Billet/Ready to Run Distributor Male Cap Kit, V8 Engine



JM6972 **BK** **BL** **R**
Pro Billet/Ready to Run Distributor Female Cap Kit, V8 Engine



JM6973 **BK** **BL** **R**
Pro Series Pro Billet/Pro Series Ready to Run Male Distributor Cap Kit, V8 Engine



JM6974 **BK** **BL** **R**
Pro Series Pro Billet/Pro Series Ready to Run Female Distributor Cap Kit, V8 Engine

JM6950
HEI Distributor Cap Kit, V8 Engine
Includes: Super Cap, Coil Cover, Rotor
Black, Blue, Clear, Gray, Red

JM6951
HEI Distributor Cap Kit, V8 Engine
Includes: OEM Cap, Coil Cover, Rotor
Black, Blue, Clear, Orange, Red

JM6952
HEI Distributor Cap Kit, 6 Cylinder
Includes: Super Cap, Coil Cover, Rotor
Black, Clear, Red

JM6953
HEI Distributor Cap Kit, 6 Cylinder
Includes: OEM Cap, Coil Cover, Rotor
Black, Blue, Clear, Red

JM6971
Pro Billet/Ready to Run Distributor Cap Kit, V8 Engine
Includes: Male Cap & Rotor
Black, Blue, Red

JM6972
Pro Billet/Ready to Run Distributor Cap Kit, V8 Engine
Includes: Female Cap & Rotor
Black, Blue, Red

JM6973
Pro Series Pro Billet/Pro Series Ready to Run Distributor Cap Kit, V8 Engine
Includes: Male Cap, Wire Retainer, Rotor
Black, Blue, Red

JM6974
Pro Series Pro Billet/Pro Series Ready to Run Distributor Cap Kit, V8 Engine
Includes: Female Cap & Rotor
Black, Blue, Red

JM6975

Pro Series Pro Billet/Pro Series Ready to Run Distributor Cap Kit, 6 Cylinder
Includes: Male Cap, Wire Retainer, Rotor Black, Blue, Red



JM6975



Pro Series Pro Billet/Pro Series Ready to Run Male Distributor Cap Kit, 6 Cylinder



JM6976



Pro Series Pro Billet/Pro Series Ready to Run Female Distributor Cap Kit, 6 Cylinder

JM6976

Pro Series Pro Billet/Pro Series Ready to Run Distributor Cap Kit, 6 Cylinder
Includes: Female Cap & Rotor Black, Blue, Red

JM6977

Ford EFI Distributor Cap Kit, 8 Cylinder
Includes: OEM Cap & Rotor Black, Blue, Red

JM6981

GM LT1 Optispark Distributor Cap Kit, 1992-1994
Includes: Cap & Rotor Black



JM6981



GM LT1 Optispark Distributor Cap Kit, 1992-1994



JM6982



GM LT1 Optispark Distributor Cap Kit, 1995-1997

JM6982

GM LT1 Optispark Distributor Cap Kit, 1995-1997
Includes: Cap & Rotor Black

JM6983

GM EFI Distributor Cap Kit V6 Engine
Includes: Cap & Rotor Red



JM6983



GM V6 EFI Distributor Cap Kit, V6 Engine

JM6984

GM EFI Distributor Cap Kit V8 Engine
Includes: Cap & Rotor Red

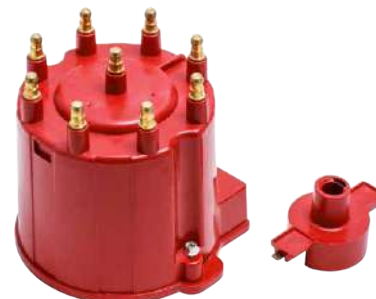

JM6984



GM V8 EFI Distributor Cap Kit, V8 Engine

JM6985

GM Vortec Distributor Cap Kit V6 Engine
Includes: Cap & Rotor Black



JM6985



GM Vortec Distributor Cap Kit, V6 Engine



JM6986



GM Vortec Distributor Cap Kit, V8 Engine

JM6986

GM Vortec Distributor Cap Kit V8 Engine
Includes: Cap & Rotor Black

**JM6991**

Complete HEI Distributor Tune Up Kit
Super Cap, 8 Cylinder

**JM6992**

Complete HEI Distributor Tune Up Kit
OEM Cap, 8 Cylinder

**JM6954BZ**

Chevy SB/BB Distributor Gear
0.491" Shaft

**JM6957S**

Oldsmobile SB/BB Distributor Gear
0.491" Shaft

**JM6958S**

Pontiac SB/BB Distributor Gear
0.491" Shaft

**JM6959S**

Ford BB/351 Cleveland Distributor
Gear 0.491" Shaft

**JM6960S**

Ford FE Distributor Gear 0.491" Shaft

**JM6961S**

Jeep Distributor Gear 0.491" Shaft

JM6991

Complete HEI Distributor Tune Up Kit
8 Cylinder
Includes: Super Cap, Coil, Module, Rotor
Black, Clear, Gray, Red

JM6992

Complete HEI Distributor Tune Up Kit
8 Cylinder
Includes: OEM Cap, Coil, Module, Rotor
Black, Blue, Clear, Orange, Red

JM6954BZ

Chevy SB/BB Distributor Gear
V6/V8 Engine, 0.491" Shaft
Bronze

JM6955S

Chevy SB/BB Distributor Gear
V6/V8 Engine, 0.491" Shaft
Steel

JM6956S

Ford SB Distributor Gear
V8 Engine, 0.491" Shaft
Steel

JM6957S

Oldsmobile SB/BB Distributor Gear
V8 Engine, 0.491" Shaft
Steel

JM6958S

Pontiac SB/BB Distributor Gear
V8 Engine, 0.491" Shaft
Steel

JM6959S

Ford BB/351 Cleveland Distributor Gear
V8 Engine, 0.491" Shaft
Steel

JM6960S

Ford FE Distributor Gear
V8 Engine, 0.491" Shaft
Steel

JM6961S

Jeep Distributor Gear
I6 Engine, 0.491" Shaft
Steel

JM6962S

Jeep Distributor Gear
V8 Engine, 0.491" Shaft
Steel

JM6963S

Chevy Distributor Gear
I6 Engine, 0.491" Shaft
Steel

JM6964S

Buick SB Distributor Gear
V8 Engine, 0.491" Shaft
Steel

JM6965S

Buick BB Distributor Gear
V8 Engine, 0.491" Shaft
Steel

JM6966BZ

Chevy SB/BB Distributor Gear
V6/V8 Engine, 0.500" Shaft
Bronze

JM6967S

Chevy SB/BB Distributor Gear
V6/V8 Engine, 0.500" Shaft
Steel

JM6968S

Ford SB Distributor Gear
V8 Engine, 0.500" Shaft
Steel

JM6969S

Ford BB/351 Cleveland Distributor Gear
V8 Engine, 0.500" Shaft
Steel

JM6970S

Chevy Corvair Distributor Gear
Flat 6 Engine, 0.491" Shaft
Steel

JM9001

Billet Aluminum Wire Loom Set,
9.5mm Smooth
Chrome, Polished

**JM6963S**

Chevy Distributor Gear 0.491" Shaft

**JM6964S**

Buick SB Distributor Gear 0.491" Shaft

**JM6965S**

Buick BB Distributor Gear 0.491" Shaft

**JM6966BZ**

Chevy SB/BB Distributor Gear
0.500" Shaft

**JM6967S**

Chevy SB/BB Distributor Gear
0.500" Shaft

**JM6969S**

Ford BB/351 Cleveland Distributor Gear
0.500" Shaft

**JM6970S**

Chevy Corvair Distributor Gear
0.491" Shaft

**JM9001**

Billet Aluminum Wire Loom Set,
Smooth



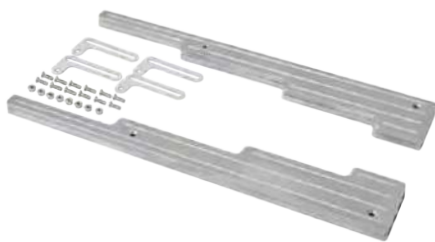

JM9002

CH P

Billet Aluminum Wire Loom Set, Ball-Milled



SP8458

P BK

Billet Aluminum Wire Loom Set, Finned

JM9002

Billet Aluminum Wire Loom Set, 9.5mm Ball-Milled Chrome, Polished

SP8458

Billet Aluminum Wire Loom Set, 9.5mm Finned Polished, Black

50051 / 50251 / 50651

Taylor StreeThunder 8mm Spark Plug Wire Set, 90° Plug Boots, Universal Fit Black, Red, Blue

50053 / 50253 / 50653

Taylor StreeThunder 8mm Spark Plug Wire Set, 135° Plug Boots, Universal Fit Black, Red, Blue

50055 / 50255 / 50655

Taylor StreeThunder 8mm Spark Plug Wire Set, 180° Plug Boots, Universal Fit Black, Red, Blue

51044 / 51244

GM LS Car Taylor StreeThunder 8mm Spark Plug Wire Set, 180° Plug Boots, 8" in length Black, Red

51045 / 51245

GM LS Car Taylor StreeThunder 8mm Spark Plug Wire Set, 135° Plug Boots, 9" in length Black, Red

51046 / 51246

GM LS Truck Taylor StreeThunder 8mm Spark Plug Wire Set, 135° Plug Boots, 10" in length Black, Red

50032 / 50232

Chevy Corvair Flat 6 Engine Taylor Spiro Pro 8mm Silicone Spark Plug Wire Set, 1961-1969 Black, Red

***Male & Female Boots Included except for 50032 & 50232**



50051 | 50251 | 50651

Taylor Wire Set, 90° Plug Boots



50053 | 50253 | 50653

Taylor Wire Set, 135° Plug Boots

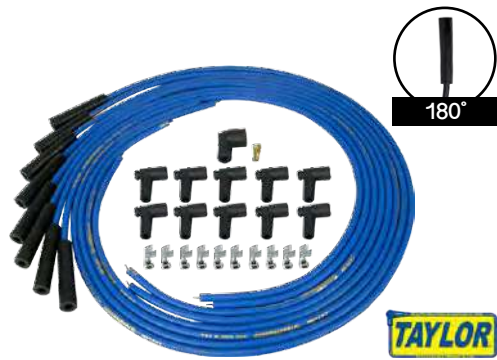

50055 | 50255 | 50655

Taylor Wire Set, 180° Plug Boots



51044 | 51244

GM LS Car Taylor Wire Set 180° Plug Boots - 8" length



51045 | 51245

GM LS Car Taylor Wire Set, 135° Plug Boots - 9" length



50032 | 50232

Chevy Corvair Taylor Wire Set



8.5mm IGNITION WIRE SET

TSP's premium ignition wires are designed for superior performance and durability. A high-quality silicone outer jacket guarantees protection from moisture and chemicals. Rated at 450°F, they hold up well to extreme heat. The spiral wound core suppresses RFI and features 500 ohm per foot resistance for excellent performance. Universal sets are available in multiple colors and boot angles.

- 8.5mm high quality silicone jacket is rated at 450° F and has a gloss finish to resist wear from chemicals and moisture
- Spiral-wound core suppresses radio frequency interference (RFI) and provides greater strength and durability
- 500 ohm-per-foot resistance increases energy to the spark plug, delivering better performance and fuel efficiency
- Matching color silicone boots to protect against high exhaust temperatures
- All universal sets come with both male and female boots with appropriate terminal ends



UNIVERSAL FIT TSP IGNITION WIRE SETS

PART NO.	DESCRIPTION	CYLINDER	WIRE COLOR
85035	135° ANGLE PLUG BOOTS	8	BLACK
85235	135° ANGLE PLUG BOOTS	8	RED
85635	135° ANGLE PLUG BOOTS	8	BLUE
85090	90° ANGLE PLUG BOOTS	8	BLACK
85290	90° ANGLE PLUG BOOTS	8	RED
85690	90° ANGLE PLUG BOOTS	8	BLUE
85080	180° STRAIGHT PLUG BOOTS	8	BLACK
85280	180° STRAIGHT PLUG BOOTS	8	RED
85680	180° STRAIGHT PLUG BOOTS	8	BLUE

ALTERNATORS



Side Battery Post: Clearance from tight cylinder head spaces

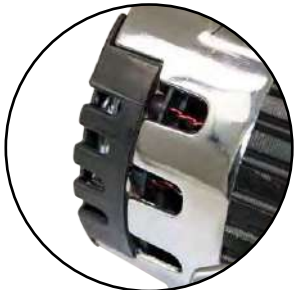

160 AMP more than stock



Ball bearing

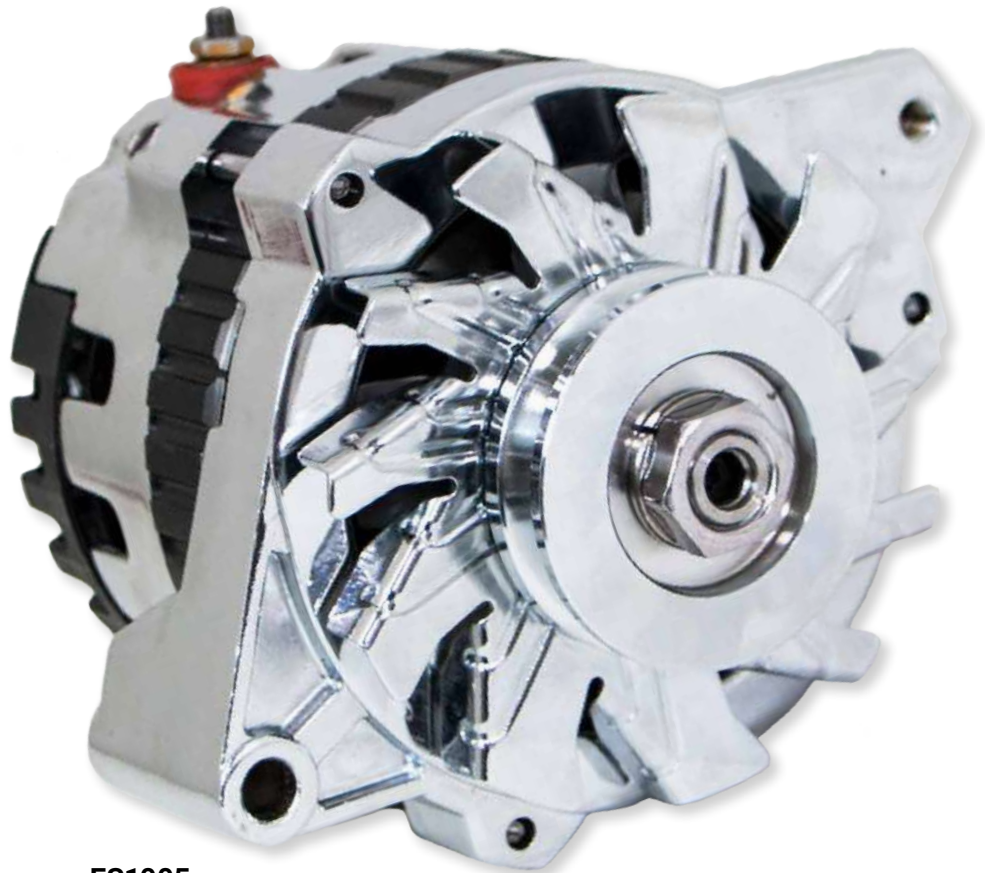

ES1005
GM CS130 Alternator with Side Battery Post, 160 AMP, V-Belt

MORE DIMENSIONS: REFER TO PAGE 143

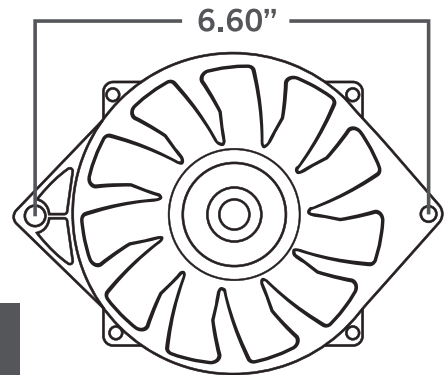

TSP's Alternators are a fantastic upgrade to any engine, whether it's for looks or performance and reliability. They feature simple wiring and a huge amperage upgrade over stock, and they come in a beautiful chrome finish with v-belt and serpentine configurations available. Why choose function over fashion when you can have both?

**ES1024**

BK CH

GM LS Truck AD244 Alternator
Serpentine Belt, 220 AMP

**ES1025**

BK CH

GM LS Car CS130D Alternator
Serpentine Belt, 180 AMP

**ES1001**

BK CH

GM 10SI Alternator V-Belt, 110 AMP

**ES1002**

CH

GM CS130 Alternator V-Belt, 110 AMP

**ES1003**

CH

GM CS130 Alternator Serpentine Belt
110 AMP

**ES1004**

BK CH S

GM Denso Style Mini Alternator
V-Belt, 90 AMP

**ES1006**

BK CH

GM CS130 Alternator Serpentine Belt,
160 AMP

**ES1022**

CH

GM CS130 Alternator V-Belt, 220 AMP

ALTERNATORS**LS ALTERNATOR****ES1024**

GM LS Truck AD244 Alternator,
220 AMP, Serpentine Belt,
4 Pin Connector
Black, Chrome

ES1025

GM LS Car CS130D Alternator,
180 AMP, Serpentine Belt,
4 Pin Connector
Black, Chrome

GM ALTERNATOR**ES1001**

GM 10SI Alternator, 110 AMP, V-Belt,
1 or OEM Wire Setup, Fits 1968-1982
Black, Chrome

ES1002

GM CS130 Alternator, 110 AMP, V-Belt,
1 or OEM Wire Setup, Fits 1968-1995
Chrome

ES1003

GM CS130 Alternator, 110 AMP,
Serpentine Belt, 1 or OEM Wire Setup,
Fits 1968-1995
Chrome

ES1004

GM Denso Style Mini Alternator,
Street Rod Race, 90 AMP, V-Belt,
1 Wire Setup
Black, Chrome, Satin

ES1005

GM CS130 Alternator with Side
Battery Post, 160 AMP, V-Belt,
1 or OEM Wire Setup, Fits 1968-1995
Chrome

ES1006

GM CS130 Alternator with Side
Battery Post, 160 AMP, Serpentine Belt,
1 or OEM Wire Setup, Fits 1968-1995
Black, Chrome

ES1022

GM CS130 Alternator, 220 AMP, V-Belt,
1 or OEM Wire Setup, Fits 1968-1995
Chrome

GM ALTERNATOR**ES1026**

GM CS130 Alternator, 220 AMP,
Serpentine Belt, 1 or OEM Wire Setup,
Fits 1968-1995
Chrome

**ES1026**

CH

GM CS130 Alternator Serpentine Belt,
220 AMP

**ES1031**

BK CH

Ford 1G Alternator V-Belt, 110 AMP

FORD ALTERNATOR**ES1031**

Ford 1G Alternator, 110 AMP, V-Belt,
1 or OEM Wire Setup, Fits 1963-1986
Black, Chrome

VW ALTERNATOR**ES1050**

VW Beetle, Mini Bus Type II 1.6L,
Melrose Sprayers with 1.6L Engine
Alternator, 55 AMP
Chrome

**ES1050**

CH

VW 1.6L Engine Alternator, 55 AMP

**ES1091**

CH

GM 10SI Alternator Dress Up Kit

ALTERNATOR REPLACEMENT PARTS**ES1091**

GM 10SI Alternator Dress Up Kit
Chrome

ES1094

Single Groove Steel Alternator Pulley
Chrome

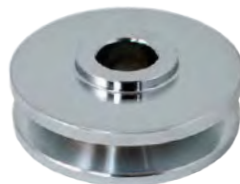
**ES1094**

CH

Single Groove Steel Alternator Pulley

ES1096

Steel Alternator Fan Blade
Chrome

**ES1096**

CH

Steel Alternator Fan Blade



STARTERS



Staggered Bolt Pattern



Compatible to 168 Tooth Flywheel



Natural Finish

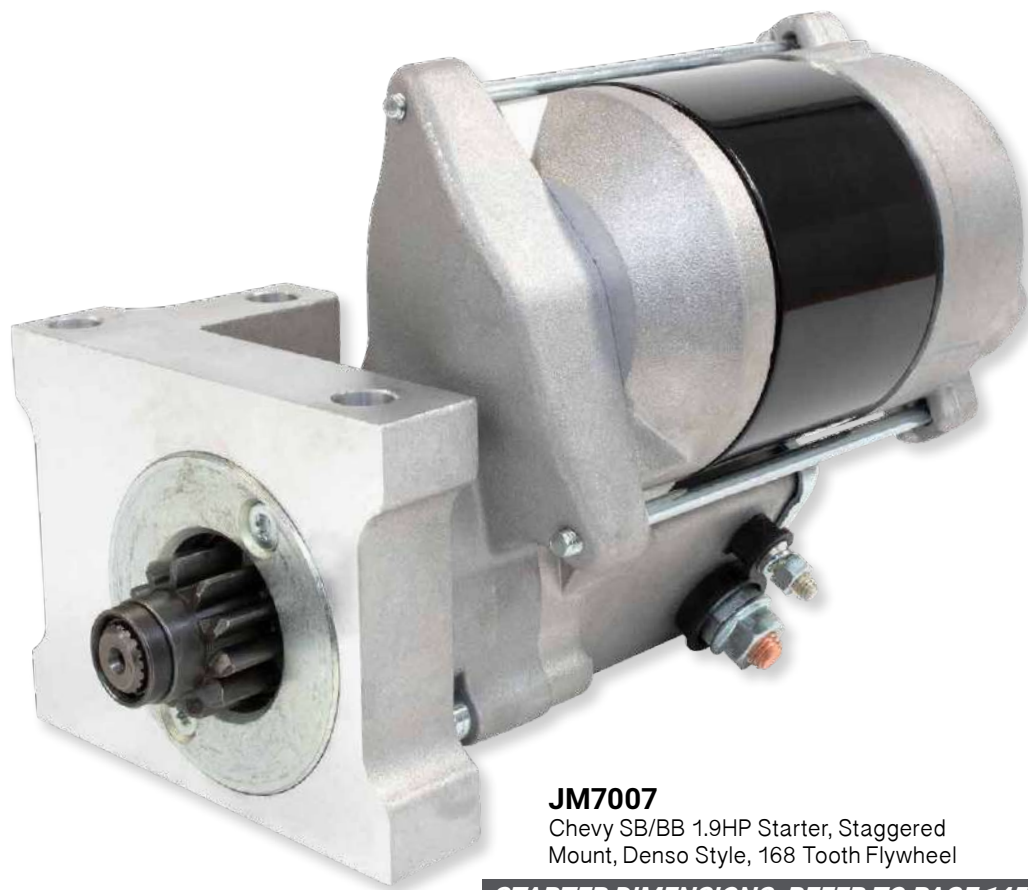

JM7007

Chevy SB/BB 1.9HP Starter, Staggered Mount, Denso Style, 168 Tooth Flywheel

STARTER DIMENSIONS: REFER TO PAGE 145

TSP's Starters guarantee reliable starting power. After all, what's the point of a high performance engine if it doesn't start? These reliable starters feature a compact design for added clearance to fit most engine configurations. They are available in multiple styles and finishes.



JM7001SK

JM7001 Shim Bolt Kit



JM7001

R BK CH

Chevy SB/BB 3HP High Torque Starter, Tilton Style



JM7002

R BK CH

GM LSX 3HP High Torque Starter, Tilton Style



JM7009

R BK A/BK

GM LSX 1.9HP Starter, Denso Style



JM7003

BK CH

Ford SB/BB/FE 3HP High Torque Starter, Tilton Style



JM7008

R BK A/BK

Oldsmobile/Pontiac 1.9HP Starter, Denso Style



JM7013

R BK A/BK

Mopar SB/BB/Hemi 1.9HP Starter, Denso Style

STARTERS

GM STARTER

The compact design from our reliable Chevy starter is now matched with a LS motor billet aluminum mounting plate which can be rotated to multiple positions for the wide range of OEM applications and LS swaps.

JM7001SK

JM7001 Shim Bolt Kit

JM7001

Chevy SB/BB 3HP High Torque Starter, 153 or 168 Tooth Flywheel, Tilton Style Red, Black, Chrome

JM7002

GM LSX 3HP High Torque Starter, Tilton Style Red, Black, Chrome

JM7007

Chevy SB/BB 1.9HP Starter, Staggered Mount, Denso Style, 168 Tooth Flywheel Red, Black, All Black

JM7009

GM LSX 1.9HP Starter, Denso Style Red, Black, All Black

FORD STARTER

JM7003

Ford SB/BB/FE 3HP High Torque Starter, Tilton Style Black, Chrome

- Will not work on manual transmission
Ford SB/BB 1979 and older;
Ford FE 1963 and older

OLDSMOBILE/PONTIAC STARTER

JM7008

Oldsmobile/Pontiac 1.9HP Starter, Denso Style Red, Black, All Black
- Will not fit 301

MOPAR STARTER

JM7013

Mopar SB/BB/Hemi 1966-1987 1.9HP Starter with Nose, Denso Style Red, Black, All Black

WATER PUMPS



1/2" Hub, 25% thicker than OEM for more durability



Made from light weight 356-T Aluminum



Heavy duty bearings & seals



8 blade cast aluminum anti-cavitation impeller



HC8012
Chevy SB Aluminum Mechanical Water Pump, Long Style

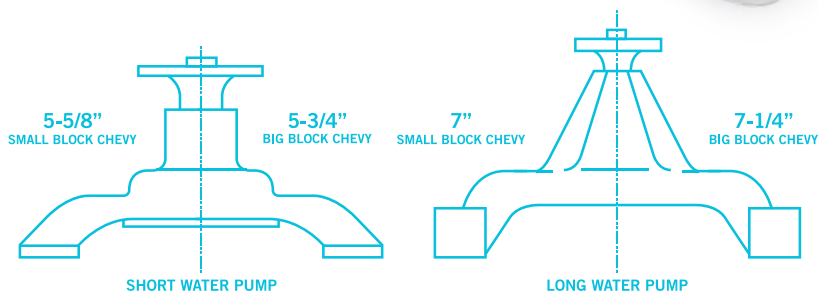

TSP's High Flow Water Pumps offer that extra cooling power you need for your street performance engine. With an 8-blade, cast aluminum anti-cavitation impeller, these flow at about 40% above most stock pumps. The heavy duty bearings and seals keep the shaft stable, ensuring excellent performance and reliability. The housings are cast from lightweight A356-T6 aluminum and come in multiple finishes to achieve any desired aesthetic.

**HC8004**

CH S P

Pontiac SB/BB

**HC8008**

CH S P

Chevy SB Corvette/Chevy SB Circle Track Short Style, 3/4" Shaft

**HC8009**

CH S P

Chevy 348/409

**HC8011**

BK CH S P

Chevy SB Short Style

**HC8013**

CH S P

Chevy SB Reverse Rotation Short Style

**HC8014**

BK CH S P

Chevy SB Reverse Rotation Long Style

**HC8021**

BK CH S P

Chevy BB Long Style

**HC8022**

BK CH S P

Chevy BB Long Style

HIGH FLOW MECHANICAL WATER PUMPS**PONTIAC WATER PUMP****HC8004**Pontiac SB/BB Aluminum Mechanical Water Pump
Chrome, Satin, Polished**CHEVY WATER PUMP****HC8008**1971-1982 Chevy SB Corvette/Chevy SB Circle Track Aluminum Mechanical Water Pump with 3/4" Shaft, Short Style
Chrome, Satin, Polished**HC8009**Chevy 348/409 Aluminum Mechanical Water Pump
Chrome, Satin, Polished**HC8011**Chevy SB Aluminum Mechanical Water Pump, Short Style
Black, Chrome, Satin, Polished**HC8012**Chevy SB Aluminum Mechanical Water Pump, Long Style
Black, Chrome, Satin, Polished**HC8013**Chevy SB Reverse Rotation Aluminum Mechanical Water Pump, Short Style
Chrome, Satin, Polished**HC8014**Chevy SB Reverse Rotation Aluminum Mechanical Water Pump, Long Style
Black, Chrome, Satin, Polished**HC8021**Chevy BB Aluminum Mechanical Water Pump, Short Style
Black, Chrome, Satin, Polished**HC8022**Chevy BB Aluminum Mechanical Water Pump, Long Style
Black, Chrome, Satin, Polished**HC8023**Chevy BB Reverse Rotation Aluminum Mechanical Water Pump, Short Style
Black, Chrome, Satin, Polished

FORD WATER PUMP

HC8049 (Passenger Side Inlet)

Ford SB 289/302/351 Windsor
Aluminum Mechanical Water Pump,
Passenger Side Inlet
Black, Chrome, Satin, Polished

HC8050 (Driver Side Inlet)

Ford SB 289/302/351 Windsor
Aluminum Mechanical Water Pump,
Driver Side Inlet
Chrome, Satin, Polished

HC8051

Ford 351 Cleveland/351M/400
Aluminum Mechanical Water Pump
Chrome, Satin, Polished

HC8052

Ford BB 429/460 Aluminum
Mechanical Water Pump
Chrome, Satin, Polished
- Will not fit 1969 Ford 429 Boss

HC8053

Ford FE 352**/390/406/410/427/428
Aluminum Mechanical Water Pump
Chrome, Satin, Polished
***Will not fit 1958-1960*

HC8054*

Ford SB 302/351 Windsor Reverse
Rotation Aluminum Mechanical
Water Pump
Fits 1985-1993
Chrome, Satin, Polished

GM LS WATER PUMP

HC8934*

GM LS1/LS2/LS6 Car, Aluminum
Mechanical Water Pump
Fits 1997-2006, OEM Replacement
Satin

HC8935*

GM LSX Truck 4.8L/5.3L/6.0L,
Aluminum Mechanical Water Pump
Fits 1999-2006, OEM Replacement
Satin

HC8936

TSP LSX Customized Aluminum
Mechanical Water Pump with Hub for
81200 Serpentine Front End Kit
Black, Chrome

*OEM Replacement



HC8049

BK CH S P

Ford SB 289/302/351 Windsor
Passenger Side Inlet



HC8050

CH S P

Ford SB 289/302/351 Windsor
Driver Side Inlet



HC8051

CH S P

Ford 351 Cleveland/351M/400



HC8052

CH S P

Ford BB 429/460



HC8053

CH S P

Ford FE 352/390/406/410/427/428



HC8054*

CH S P

Ford SB 302/351 Windsor
Reverse Rotation



HC8934*

S

GM LS1/LS2/LS6 Car Aluminum
Mechanical Water Pump



HC8935*

S

GM LSX Truck 4.8L/5.3L/6.0L Aluminum
Mechanical Water Pump

**HC8010**

Chevy SB

BK CH

**HC8020**

Chevy BB

BK CH

**HC8030**

Ford SB 289/302/351 Windsor

BK CH

**HC8031**

Ford 351 Cleveland

BK CH

**HC8040**

Ford BB 429/460

BK CH

**SP8455**

Chevy SB/BB 45° Aluminum Water Neck

BK P

**SP8456**

Chevy SB/BB 90° Aluminum Water Neck

BK P

**SP8459**

Chevy SB/BB 15° Aluminum Water Neck

BK P

HIGH FLOW ELECTRIC WATER PUMPS**CHEVY WATER PUMP****HC8010**Chevy SB 35 GPM Aluminum Electric Water Pump
Black, Chrome*- Will not fit with an 8" harmonic balancer***HC8020**Chevy BB 35 GPM Aluminum Electric Water Pump
Black, Chrome**FORD WATER PUMP****HC8030**Ford SB 289/302/351 Windsor 35 GPM Aluminum Electric Water Pump,
Back Plate Included
Black, Chrome**HC8031**Ford 351 Cleveland 35 GPM Aluminum Electric Water Pump, Back Plate Included
Black, Chrome**HC8040**Ford BB 429/460 35 GPM Aluminum Electric Water Pump, Back Plate Included
Black, Chrome**WATER NECKS****SP8455**Chevy SB/BB 45° Aluminum Water Neck
360° Swivel, 283-454 V8 Engine
Black, Polished**SP8456**Chevy SB/BB 90° Aluminum Water Neck
360° Swivel, 283-454 V8 Engine
Black, Polished**SP8459**Chevy SB/BB 15° Aluminum Water Neck
360° Swivel, 283-454 V8 Engine
Black, Polished**HC8937**LS 45° Aluminum Water Neck
360° Swivel
Black, Chrome**HC8938**LS Straight Aluminum Water Neck
Black, Chrome**HC8939**

LSX -12AN Fitting Water Neck and Water Pump Adapter

RADIATOR, FAN AND SHROUD



HC9511

Universal Chevy Single Fan Pro Flow Radiator Kit

Cut-outs with flaps for increased airflow

TSP's Radiators are constructed of lightweight aluminum and are 100% TIG welded, using absolutely no epoxy. They feature an extremely efficient cross-flow design with two rows of 1" tubes and 17 fins per inch. These design features ensure maximum cooling capacity for your engine. With configurations for Chevy, Ford, and Mopar, they are available in multiple sizes to fit most applications. Combine with our Pro Flow fans and aluminum shrouds for a complete, easy-to-install cooling kit.



CHEVY

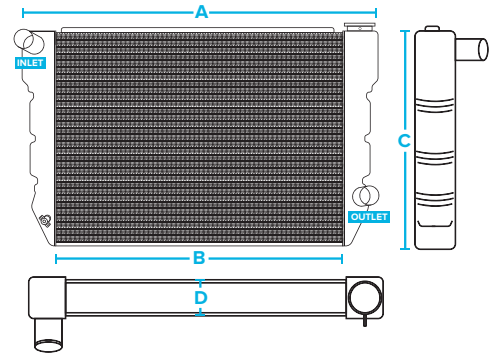

CHEVY RADIATORS	DIM. A (Width)	DIM. B (Width)	DIM. C (Height)	DIM. D (Depth)	INLET	OUTLET
HC6011	31"	26 1/4"	19 1/4"	2 1/4"	1 1/2"	1 3/4"
HC6012	29"	24 1/4"	19 1/4"	2 1/4"	1 1/2"	1 3/4"
HC6013	26"	21 1/4"	19 1/4"	2 1/4"	1 1/2"	1 3/4"
HC6014	24"	19 1/4"	19 1/4"	2 1/4"	1 1/2"	1 3/4"
HC6015	22 "	17 1/4"	19 1/4"	2 1/4"	1 1/2"	1 3/4"

FORD/MOPAR

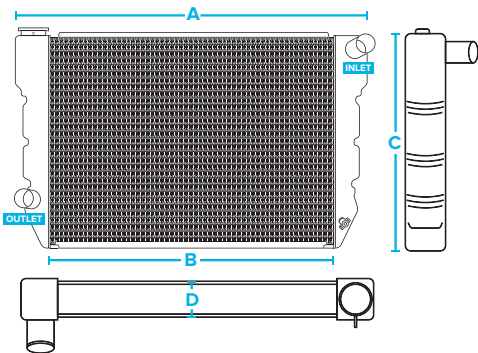

FORD/MOPAR RADIATORS	DIM. A (Width)	DIM. B (Width)	DIM. C (Height)	DIM. D (Depth)	INLET	OUTLET
HC6016	31"	26 1/4"	19 1/4"	2 1/4"	1 1/2"	1 3/4"
HC6017	29"	24 1/4"	19 1/4"	2 1/4"	1 1/2"	1 3/4"
HC6018	26"	21 1/4"	19 1/4"	2 1/4"	1 1/2"	1 3/4"
HC6019	24"	19 1/4"	19 1/4"	2 1/4"	1 1/2"	1 3/4"
HC6020	22 "	17 1/4"	19 1/4"	2 1/4"	1 1/2"	1 3/4"

HC7599
Fan Shroud Flap

HC6201P
Aluminum Billet Radiator Cap
Polished

HC6304C
48" Stainless Steel Radiator Hose Kit
Chrome

HC6310C
44" Stainless Steel Heater Hose Kit
Chrome



HC7599

Fan Shroud Flap



HC6201P

Aluminum Billet Radiator Cap

P



HC6304C

48" Radiator Hose Kit

CH



HC6310C

44" Heater Hose Kit

CH

UNIVERSAL TRANSMISSION OIL COOLERS



PRODUCT NO.	LENGTH	HEIGHT	WIDTH	INLET/OUTLET
HC6341	12 3/4"	5"	3/4"	3/8"
HC6342	15 1/2"	5"	3/4"	3/8"
HC6343	12 3/4"	7 1/2"	3/4"	3/8"
HC6344	15 1/2"	7 1/2"	3/4"	3/8"
HC6345	15 1/2"	10"	3/4"	3/8"
HC6346	15 1/2"	12 1/2"	3/4"	3/8"



**Accessories Included*

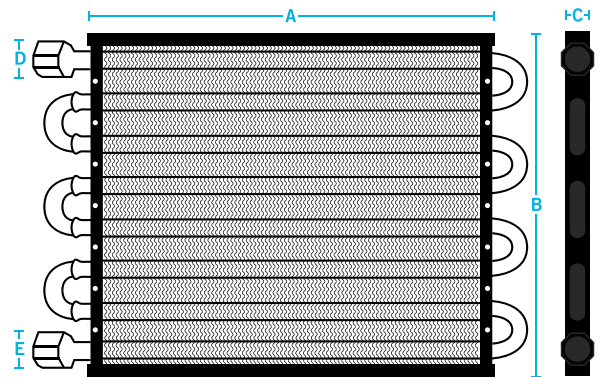

PRODUCT NO.	LENGTH	HEIGHT	WIDTH	INLET/OUTLET
HC6352	12 3/4"	7 1/2"	3/4"	M18 x 1.5" FITTING
HC6354	15 1/2"	7 1/2"	3/4"	M18 x 1.5" FITTING
HC6356	15 1/2"	10"	3/4"	M18 x 1.5" FITTING



**Accessories Included*

ALUMINUM FAN SHROUDS, SINGLE FAN

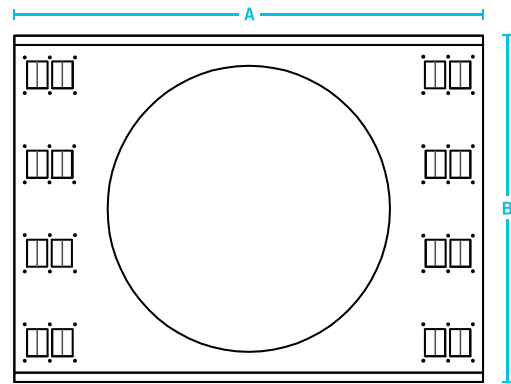
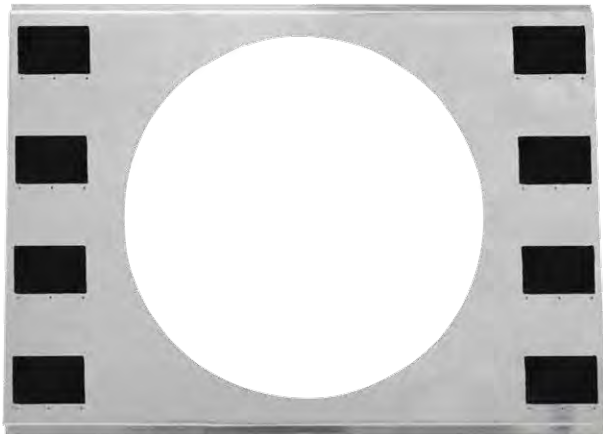

PRODUCT NO.	DIM. A	DIM. B	APPLICATION	CFM
HC7511	25 3/4"	18 3/4"	PRO FLOW 16" FAN	2,000
HC7512	23 3/4"	18 3/4"	PRO FLOW 16" FAN	2,000

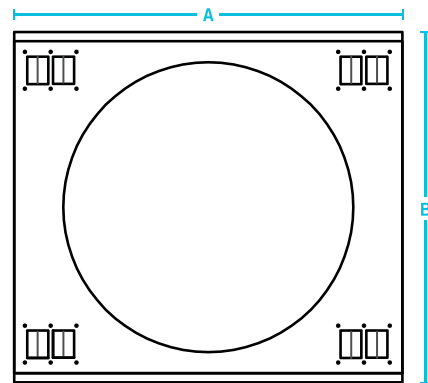
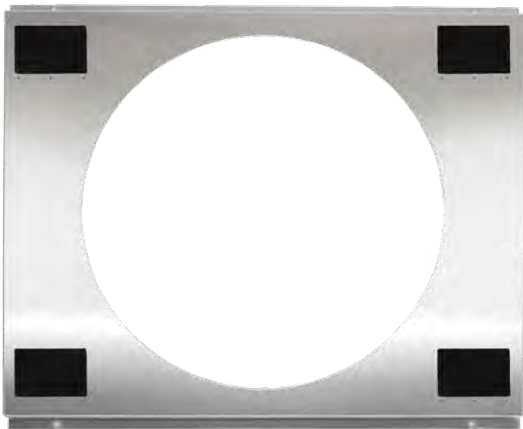

PRODUCT NO.	DIM. A	DIM. B	APPLICATION	CFM
HC7513	20 3/4"	18 3/4"	PRO FLOW 16" FAN	2,000
HC7514	18 3/4"	18 3/4"	PRO FLOW 16" FAN	2,000
HC7515	16 3/4"	18 3/4"	PRO FLOW 16" FAN	2,000

ALUMINUM FAN SHROUDS, DUAL FANS

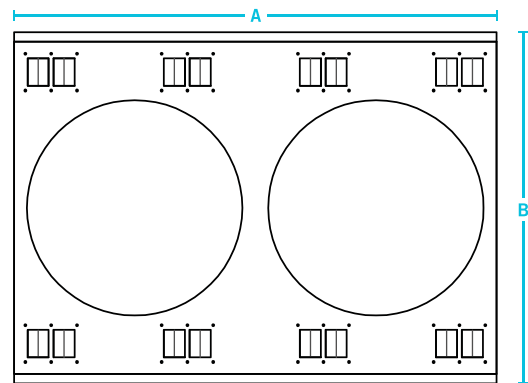
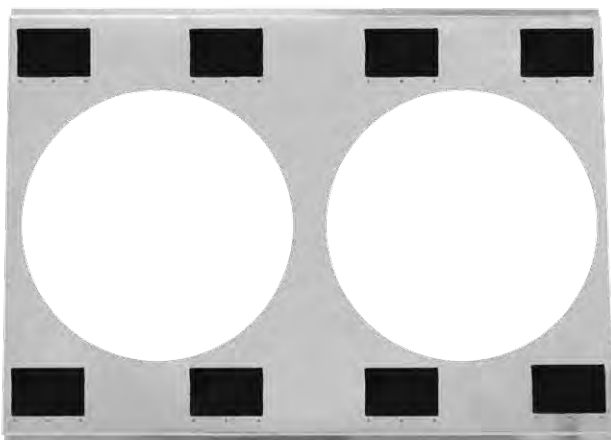

PRODUCT NO.	DIM. A	DIM. B	APPLICATION	CFM
HC7511D	25 3/4"	18 3/4"	PRO FLOW 11" FAN	2,800
HC7512D	23 3/4"	18 3/4"	PRO FLOW 11" FAN	2,800

ALUMINUM FAN SHROUD KITS



PRODUCT NO.	DESCRIPTION
HC8511	25" Aluminum Fan Shroud & Single 16" Fan Kit
HC8512	23" Aluminum Fan Shroud & Single 16" Fan Kit
HC8513	20" Aluminum Fan Shroud & Single 16" Fan Kit
HC8514	18" Aluminum Fan Shroud & Single 16" Fan Kit
HC8515	16" Aluminum Fan Shroud & Single 16" Fan Kit

PRODUCT NO.	DESCRIPTION
HC8511D	25" Aluminum Fan Shroud & Pro Flow 11" Fan Kit
HC8512D	23" Aluminum Fan Shroud & Pro Flow 11" Fan Kit



PRODUCT NO.	DESCRIPTION
HC9511	25" Aluminum Fan Shroud, Pro Flow 16" Fan & 31" Chevy Radiator Kit
HC9512	23" Aluminum Fan Shroud, Pro Flow 16" Fan & 29" Chevy Radiator Kit
HC9513	20" Aluminum Fan Shroud, Pro Flow 16" Fan & 26" Chevy Radiator Kit
HC9514	18" Aluminum Fan Shroud, Pro Flow 16" Fan & 24" Chevy Radiator Kit
HC9515	16" Aluminum Fan Shroud, Pro Flow 16" Fan & 22" Chevy Radiator Kit
HC9516	25" Aluminum Fan Shroud, Pro Flow 16" Fan & 31" Ford/Mopar Radiator Kit
HC9517	23" Aluminum Fan Shroud, Pro Flow 16" Fan & 29" Ford/Mopar Radiator Kit
HC9518	20" Aluminum Fan Shroud, Pro Flow 16" Fan & 26" Ford/Mopar Radiator Kit
HC9519	18" Aluminum Fan Shroud, Pro Flow 16" Fan & 24" Ford/Mopar Radiator Kit
HC9520	16" Aluminum Fan Shroud, Pro Flow 16" Fan & 22" Ford/Mopar Radiator Kit

PRODUCT NO.	DESCRIPTION
HC9511D	25" Aluminum Fan Shroud, Pro Flow 11" Fan & 31" Chevy Radiator Kit
HC9512D	23" Aluminum Fan Shroud, Pro Flow 11" Fan & 29" Chevy Radiator Kit
HC9516D	25" Aluminum Fan Shroud, Pro Flow 11" Fan & 31" Ford/Mopar Radiator Kit
HC9517D	23" Aluminum Fan Shroud, Pro Flow 11" Fan & 29" Ford/Mopar Radiator Kit



OVERFLOW TANKS

Top Street Performance polished stainless steel overflow tanks add style to an engine compartment with a sleek design. They feature a twist on aluminum cap, 5/16" pipe size, and includes complete hardware and brackets to fit your application.



HC6321
2" x 10" Overflow Tank, Stainless Steel
Fluid Capacity: 14 oz.



HC6322
2" x 13" Overflow Tank, Stainless Steel
Fluid Capacity: 18 oz.



HC6323
2" x 15" Overflow Tank, Stainless Steel
Fluid Capacity: 22 oz.



HC6324
2" x 17" Overflow Tank, Stainless Steel
Fluid Capacity: 26 oz.



HC6325
2" x 19" Overflow Tank, Stainless Steel
Fluid Capacity: 30 oz.



**Mounting Brackets and Hardware Included*



HC6326
3" x 9" Overflow Tank, Stainless Steel
Fluid Capacity: 24 oz.



HC6327
3" x 10" Overflow Tank, Stainless Steel
Fluid Capacity: 34 oz.



**Mounting Brackets and Hardware Included*



HC6328
3" x 16" Overflow Tank, Stainless Steel
Fluid Capacity: 52 oz.

**HC5001**

BK CH

Sanden 508 Style V-Belt

**HC5002**

BK CH

Sanden 508 Style Serpentine Belt

**HC5003**

CH

Sanden 508 Style V-Belt

**HC5004**

CH

Sanden 508 Style Serpentine Belt

**HC5005**

BK CH

Sanden SD-7 Style Serpentine Belt

A/C COMPRESSORS

*TSP compressors include
PAG 100 oil

HC5001

Sanden 508 R134A Style
A/C Compressor V-Belt, Black Clutch
Black, Chrome

HC5002

Sanden 508 R134A Style
A/C Compressor Serpentine Belt,
Black Clutch
Black, Chrome

HC5003

Sanden 508 R134A Style
A/C Compressor V-Belt, Silver Clutch
Chrome

HC5004

Sanden 508 R134A Style
A/C Compressor Serpentine Belt,
Silver Clutch
Chrome

HC5005

Sanden SD-7 Style A/C Compressor
Serpentine Belt, 6 Groove, Silver Clutch
Black, Chrome

ELECTRIC COOLING FANS



HC6105

HC6104

HC6103

HC6102

HC6101



HC6105C

HC6104C

HC6103C

HC6102C



*Mounting kit included

STANDARD FANS

HC6101*

8" Universal Electric Cooling Fan
Straight Blade - Black

*Reversible Straight Blade Design

HC6102*

10" Universal Electric Cooling Fan
S-Blade - Black, Chrome

HC6103*

12" Universal Electric Cooling Fan
S-Blade - Black, Chrome

HC6104*

14" Universal Electric Cooling Fan
S-Blade - Black, Chrome

HC6105*

16" Universal Electric Cooling Fan
S-Blade - Black, Chrome

* Reversible S-Blade design

* Configured as a puller and converts to a pusher

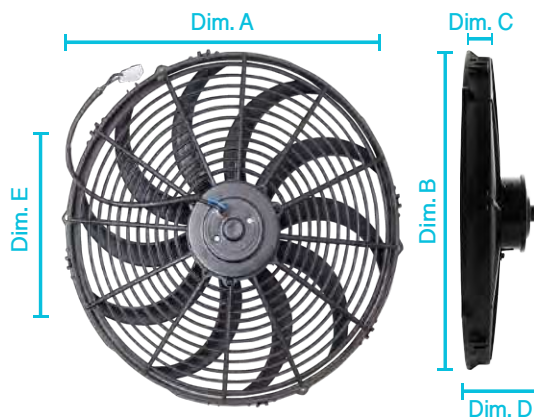

PRODUCT NO.	FAN SIZE	DIM. A	DIM. B	DIM. C	DIM. D	DIM. E
HC6101	8"	8 1/8"	8"	1 1/4"	2 1/4"	4 3/8"
HC6102	10"	11 1/2"	10 3/4"	1 1/2"	2 3/8"	8 7/8"
HC6103	12"	13"	12 5/8"	1 1/2"	2 3/8"	6 3/16"
HC6104	14"	14 3/8"	14"	1 1/2"	3 3/8"	7 1/8"
HC6105	16"	16 1/2"	15 5/8"	1 1/8"	3 3/8"	14"



HC7105

HC7104

HC7103

HC7102



*Mounting kit included

PRODUCT NO.	FAN SIZE	CFM	AMP DRAW	DIM. A	DIM. B	DIM. C	DIM. D	DIM. E
HC7102	10"	650	7.5	10 5/8"	11 1/4"	1 1/4"	2 1/2"	5 5/8"
HC7103	12"	870	10	11 5/8"	11 3/4"	1 3/8"	2 1/2"	6 7/8"
HC7104	14"	1200	12	14 3/16"	15 1/4"	1 3/8"	3 1/2"	7 7/8"
HC7105	16"	1600	14	15 5/8"	16"	1 3/8"	3 3/4"	8 7/8"



HC7106

BK

11" High Performance Dual Electric Cooling Fan, Straight Blade

- Two piece heavy duty shroud
- High output motors

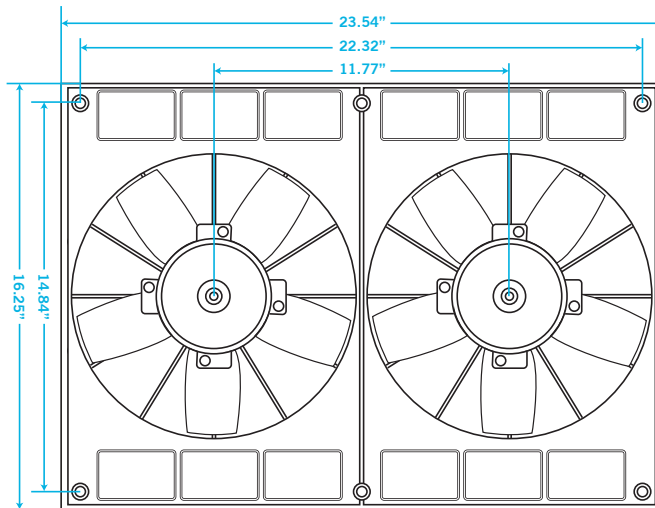

DIMENSIONS ARE IN INCHES

PRO SERIES FANS

HC7102*

10" Pro Series Universal Electric Cooling Fan, 7.5 AMP, S-Blade - Black

HC7103*

12" Pro Series Universal Electric Cooling Fan, 10 AMP, S-Blade - Black

HC7104*

14" Pro Series Universal Electric Cooling Fan, 12 AMP, S-Blade - Black

HC7105*

16" Pro Series Universal Electric Cooling Fan, 14 AMP, S-Blade - Black

HC7106

11" High Performance Dual Electric Cooling Fan, 25 AMP, Straight Blade, Puller, 2,800 CFM - Black

* Reversible S-Blade design

* Configured as a puller and converts to a pusher

PRO FLOW FANS

HC7211

11" Pro Flow Universal Electric Cooling Fan, Straight Blade, Puller, 1,400 CFM Black

HC7212

12" Pro Flow Universal Electric Cooling Fan, Straight Blade, Puller, 1,600 CFM Black

HC7214

14" Pro Flow Universal Electric Cooling Fan, Straight Blade, Puller, 1,800 CFM Black

HC7216

16" Pro Flow Universal Electric Cooling Fan, Straight Blade, Puller, 2,000 CFM Black

FAN ACCESSORIES

HC6100

HC61XX Series Electric Cooling Fan Mounting Kit Black

HC7100

HC7102, 03, Electric Cooling Fan Mounting Kit Black

HC7101

HC7105 Electric Cooling Fan Mounting Kit Black

HC7107

HC7104 Electric Cooling Fan Mounting Kit Black

HC7108

Pro Series Electric Fan Relay Wiring Harness Kit, 40-50 AMP 165°-185° F



FAN DIMENSIONS: REFER TO PAGE 142

HC7211

BK

11" Pro Flow Universal Electric Cooling Fan, Straight Blade

HC7212

BK

12" Pro Flow Universal Electric Cooling Fan, Straight Blade



FAN DIMENSIONS: REFER TO PAGE 142

HC7214

BK

14" Pro Flow Universal Electric Cooling Fan, Straight Blade

HC7216

BK

16" Pro Flow Universal Electric Cooling Fan, Straight Blade



HC6100

BK

HC61XX Series Electric Cooling Fan Mounting Kit

HC7100

BK

HC7102, 03, Electric Cooling Fan Mounting Kit



HC7101

BK

HC7105 Electric Cooling Fan Mounting Kit

HC7108

Pro Series Electric Fan Relay Wiring Harness Kit



HC7108W
Pro Series Electric Fan Pigtail



HC7109
HC71XX Series Fan Pigtail Harness

HC7108W
Pro Series Electric Fan Pigtail

HC7109
HC71XX Series Fan Pigtail Harness

HC7110
Adjustable Electric Fan Controller Wiring Harness Kit, Thread-in Thermostat, 150°-240° F
Black, Red

HC7111
Adjustable Electric Fan Controller Wiring Harness Kit, Probe Thermostat, 150°-240° F
Black, Red

HC7112
Thread-in Thermostat, 3/8 NPT

HC7113
Radiator Fin Probe Thermostat

HC7114
30 AMP Fuse

HC7115
40 AMP Fuse

HC7116
Pro Series 165°-185° F Thermostat, 3/8 NPT

HC7117
40/50 AMP Relay

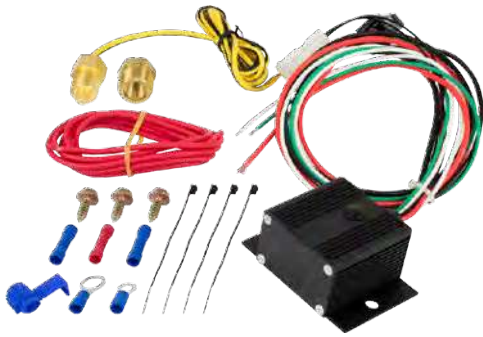

HC7110 BK R
Adjustable Electric Fan Controller Wiring Harness Kit, Thread-in Thermostat



HC7111 BK R
Adjustable Electric Fan Controller Wiring Harness Kit, Probe Thermostat



HC7112
Thread-in Thermostat, 3/8 NPT



HC7113
Radiator Fin Probe Thermostat



HC7116
Pro Series 165°-185° F Thermostat, 3/8 NPT



HC7117
40/50 AMP Relay

DS35012: SBC FRONT DRIVE SYSTEM

TSP's Small Block Chevy V-Belt Front Drive System is one of our most popular offerings. With chrome and polished brackets, pulleys, and accessories, it's a great way to dress up the front of your hot rod or muscle car engine.

- **HC8012** : Mechanical Water Pump, Long Style, Chrome
- **ES1001** : Alternator, V-Belt, 110 AMP, Chrome
- **JM2000** : Saginaw Power Steering Pump, Chrome
- **JM9101** : Alternator Brackets, Chrome
- **JM9105** : Power Steering Brackets, Chrome
- **SP8857** : Double Groove Crankshaft Pulley, Polished
- **SP8854** : Single Groove Water Pump Pulley, Polished
- **SP8848** : Single Groove Power Steering Pulley, Polished

*Note: Bolts not included



DS35012ABK: ALL BLACK SBC FRONT DRIVE SYSTEM

With black brackets, pulleys, and accessories, it's a great way to dress up the front of your hot rod or muscle car engine.

- **HC8012** : Mechanical Water Pump, Long Style, Black
- **ES1001** : Alternator, V-Belt, 110 AMP, Black
- **JM2000** : Saginaw Power Steering Pump, Black
- **JM9101** : Alternator Brackets, Black
- **JM9105-1** : Power Steering Brackets, Black
- **SP8857** : Double Groove Crankshaft Pulley, Black
- **SP8854** : Single Groove Water Pump Pulley, Black
- **SP8848** : Single Groove Power Steering Pulley, Black

*Note: Bolts not included



DS35014: SBC SERPENTINE FRONT DRIVE SYSTEM

TSP's serpentine kit is a perfect and compact solution for your Chevy small block engine. Complete with all accessories, brackets, and pulleys, it comes in a stylish black or pristine polished finish.

- **HC8014** : Reverse Rotation Mechanical Water Pump, Long Style, Black
- **ES1006** : Alternator w/ Side Battery Post, Serpentine Belt, 160 AMP, Black
- **HC5005** : A/C Compressor Sanden SD-7 Style, Serpentine Belt, Black
- **JM2010** : GM Type II Power Steering Pump, -10AN Inlet, -6AN Outlet, Black
- **85000** : Chevy SB Accessory Plates, Black
- **85001** : Chevy SB Serpentine Pulley, Black
- **Belt no. K060650**
- **Tensioner no. 38163**

*Note: Bolts not included



DS45422: BBC FRONT DRIVE SYSTEM

TSP's Big Block Chevy V-Belt Front Drive System is a great start to dressing up your engine bay. It comes with everything you need, including a high-flow water pump, a 110 AMP alternator, and a Saginaw power steering pump, plus all the necessary brackets and pulleys. All parts come in a polished or chrome finish, so it's a beautiful addition to any engine.

- **HC8022** : Mechanical Water Pump, Long Style, Chrome
- **ES1001** : Alternator, V-Belt, 110 AMP, Chrome
- **JM2000** : Saginaw Power Steering Pump, Chrome
- **JM9103** : Alternator Brackets, Chrome
- **JM9115** : Power Steering Brackets, Chrome
- **SP8839** : Double Groove Crankshaft Pulley, Polished
- **SP8838** : Double Groove Water Pump Pulley, Polished
- **SP8848** : Single Groove Power Steering Pulley, Polished

*Note: Bolts not included



DS45423: BBC SERPENTINE FRONT DRIVE SYSTEM

Set up your big block Chevy with TSP's serpentine front drive kit. It comes with brackets, pulleys, and all the accessories. It also comes complete with the belt tensioner.

- **HC8023** : Reverse Rotation Mechanical Water Pump, Short Style, Chrome
- **ES1006** : Alternator w/ Side Battery Post, Serpentine Belt, 160 AMP, Chrome
- **HC5005** : A/C Compressor Sanden SD-7 Style, Serpentine Belt, Chrome
- **JM2010** : GM Type II Power Steering Pump, -10AN Inlet, -6AN Outlet, Chrome
- **85001** : Chevy BB Serpentine Pulley, Polished
- **86000** : Chevy BB Accessory Plates, Polished
- **Belt no. K060680**
- **Tensioner no. 38163**

*Note: Bolts not included



DS30249: SBF FRONT DRIVE SYSTEM

This front drive kit offers a complete set-up for your small block Ford. With all brackets, pulleys, and accessories in a gorgeous chrome finish, it'll be a great addition to your engine.

- **HC8049** : Mechanical Water Pump, Passenger Side Inlet, Chrome
- **ES1031** : Alternator, V-Belt, 110 AMP, Chrome
- **JM2000** : Saginaw Power Steering Pump, Chrome
- **JM9117** : Power Steering Brackets, Chrome
- **JM9113** : Alternator Brackets, Chrome
- **SP8948** : Single Groove Power Steering Pulley, Chrome
- **SP8974** : Double Groove Power Crankshaft Pulley, Chrome
- **SP8975** : Double Groove Water Pump Pulley, Chrome

*Note: Belts and Bolts not included

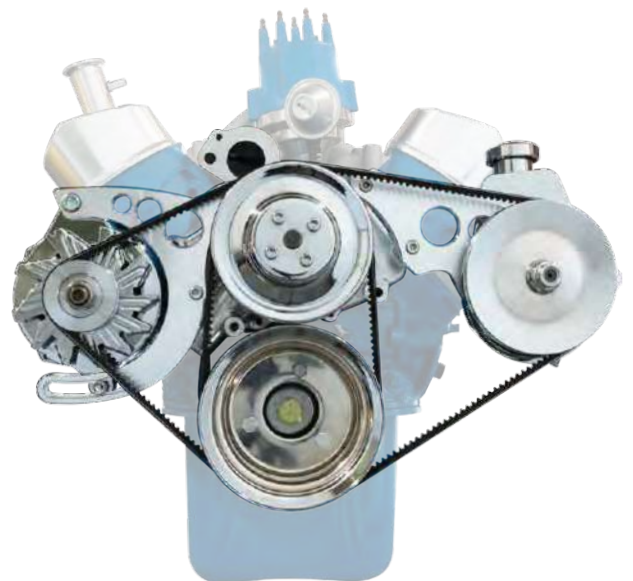

BRACKETS & PULLEYS



CNC Machined



High quality chrome finish



Made Out of Aluminum 6061-T6



JM9105-1 (New Design)
Chevy SB LWP, Aluminum Power
Steering Pump Bracket Kit

TSP's Brackets and Pulleys offer an immediately noticeable upgrade to your engine. We have pulleys available in multiple materials and finishes to match any engine set-up. Our brackets are CNC-machined from 6061-T6 aluminum to ensure precise alignment and stability for your accessories. They come complete with all mounting hardware and are available in a chrome or polished finish.

**JM9101**

BK CH P

Chevy SB LWP, Aluminum Alternator Bracket Kit

**JM9102**

CH P

Chevy SB SWP, Aluminum Alternator Bracket Kit

CHEVY SMALL BLOCK BRACKET KIT**JM9101**

Chevy SB Long Water Pump, Passenger Side, Aluminum Alternator Bracket Kit Black, Chrome, Polished

JM9102

Chevy SB Short Water Pump, Driver Side, Aluminum Alternator Bracket Kit Chrome, Polished

JM9105

Chevy SB Long Water Pump, Aluminum Power Steering Pump Bracket Kit Black, Chrome, Polished

JM9105-1 (New Design)

Chevy SB Long Water Pump, Aluminum Power Steering Pump Bracket Kit Black, Chrome, Polished

JM9106

Chevy SB Long Water Pump, Driver Side, Aluminum A/C Compressor Bracket Kit Black, Chrome, Polished

JM9116

Chevy SB Type II Short Water Pump, Steel Power Steering Pump Bracket Kit Black, Chrome Steel

JM9121

Chevy SB Long Water Pump, Aluminum Alternator Bracket Kit Black, Chrome, Polished

JM9131

Chevy SB Long Water Pump, Mid Mount Aluminum Alternator Bracket Kit Black, Chrome, Polished

CHEVY BIG BLOCK BRACKET KIT**JM9103**

Chevy BB Long Water Pump, Passenger Side, Aluminum Alternator Bracket Kit Black, Chrome, Polished

JM9104

Chevy BB Short Water Pump, Driver Side, Aluminum Alternator Bracket Kit Chrome, Polished

**JM9105**

BK CH P

Chevy SB LWP, Aluminum Power Steering Pump Bracket Kit

**JM9106**

BK CH P

Chevy SB LWP, Aluminum A/C Compressor Bracket Kit

**JM9116**

BK CH

Chevy SB Type II SWP, Power Steering Pump Bracket Kit

**JM9121**

BK CH P

Chevy SB LWP, Aluminum Alternator Bracket Kit

**JM9131**

BK CH P

Chevy SB LWP, Mid Mount, Aluminum Alternator Bracket Kit

**JM9103**

BK CH P

Chevy BB LWP, Aluminum Alternator Bracket Kit

JM9115

Chevy BB Long Water Pump, Aluminum Power Steering Pump Bracket Kit
Brushed Aluminum, Chrome, Polished

JM9123

Chevy BB Long Water Pump, Aluminum Alternator Bracket Kit
Black, Chrome, Polished

JM9133

Chevy BB Long Water Pump, Mid Mount Aluminum Alternator Bracket Kit
Black, Chrome, Polished

FORD SMALL BLOCK BRACKET KIT**JM9111**

Ford SB 289 & 302 Aluminum Alternator Bracket Kit
Chrome, Polished

JM9112

Ford 351 Windsor Aluminum Alternator Bracket Kit
Chrome, Polished

JM9113

Ford SB 289 & 302, Low Mount Aluminum Alternator Bracket Kit
Chrome, Polished

JM9117

Ford SB 289 & 302 Aluminum Power Steering Pump Bracket Kit
Chrome, Polished

**Must use saginaw pump*

FORD BIG BLOCK BRACKET KIT**JM9114**

Ford BB 429 & 460 Aluminum Alternator Bracket Kit
Chrome, Polished

**JM9115**

BA CH P

Chevy BB LWP, Aluminum Power Steering Pump Bracket Kit

**JM9123**

BK CH P

Chevy BB LWP, Aluminum Alternator Bracket Kit

**JM9133**

BK CH P

Chevy BB LWP, Mid Mount, Aluminum Alternator Bracket Kit

**JM9111**

CH P

Ford SB 289 & 302 Aluminum Alternator Bracket Kit

**JM9112**

CH P

Ford 351 Windsor Aluminum Alternator Bracket Kit

**JM9117**

CH P

Ford SB 289 & 302 Aluminum Power Steering Pump Bracket Kit

**JM9114**

CH P

Ford BB 429 & 460 Aluminum Alternator Bracket Kit



TSP
TO STREET PERFORMANCE

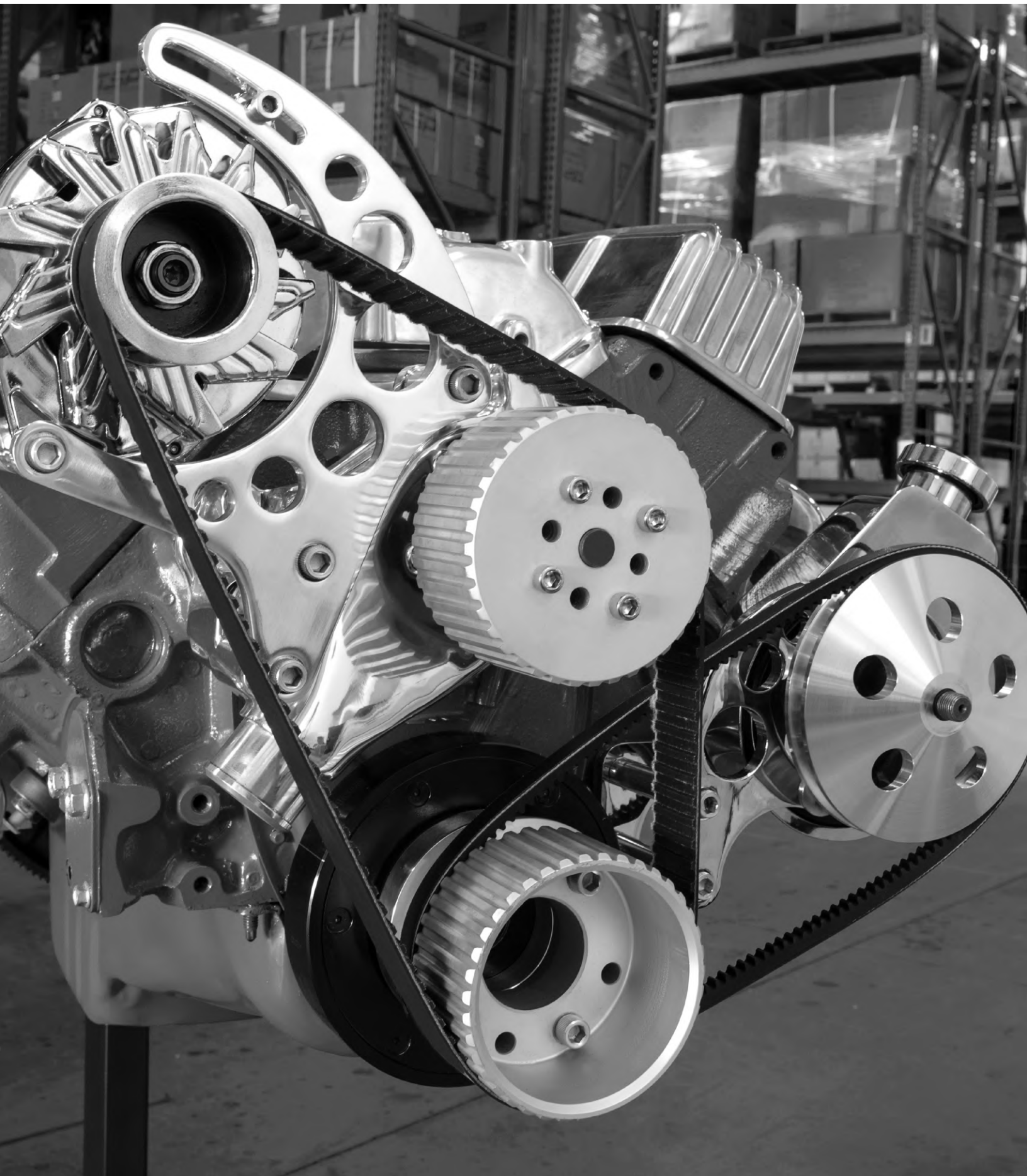

GILMER STYLE PULLEY KIT

Gilmer pulleys are a great solution for any racing set-up. They eliminate the problem of slippage and disengagement you'd experience at high RPM with a V-Belt. Each kit comes with pulleys for the crank, water pump, and alternator, and 1.5" wide belt. Regardless of application, TSP's Gilmer style pulley kit is an efficient and lightweight option for your high-performance engine.



GILMER STYLE PULLEY KIT	DESCRIPTION
10090	Chevy SB V8 Engine Short Water Pump Gilmer Style Pulley Kit
10091	Chevy SB V8 Engine Long Water Pump Gilmer Style Pulley Kit
10092	Chevy BB V8 Engine Short & Long Water Pump Gilmer Style Pulley Kit
10093	Ford SB 302-351W V8 Engine Gilmer Style Pulley Kit
10094	Ford BB 429-460 Gilmer Style Pulley Kit
10095	Ford 351 Cleveland Gilmer Style Pulley Kit
10096	Mopar SB 318/340/360 Gilmer Style Pulley Kit
10097	Mopar BB 383-440 Gilmer Style Pulley Kit
10367	36.7" Replacement Belt
10390	39" Replacement Belt
10405	40.5" Replacement Belt
10420	42" Replacement Belt
10450	45" Replacement Belt
10480	48" Replacement Belt
10087	2-3/4" Bolt Kit Only
10088	Chevy SB/BB & Ford SB Gilmer Style Drive Crankshaft Pulley 5/8" with 2-3/4" Bolt Kit



CHEVY SMALL BLOCK LONG WATER PUMP

WATER PUMP

SP8854

Chevy SB Water Pump Pulley, Single Groove - Aluminum (Machined, Polished)

SP8856

Chevy SB Water Pump Pulley, Double Groove - Aluminum (Machined, Polished)

SP8864

Chevy SB Water Pump Nose Pulley Aluminum (Machined)

CRANKSHAFT

SP8855

Chevy SB Crankshaft Pulley, Single Groove - Aluminum (Machined)

SP8955

Chevy SB Crankshaft Pulley, Single Groove - Chrome Steel

SP8857

Chevy SB Crankshaft Pulley, Double Groove - Aluminum (Machined, Polished)

SP8957

Chevy SB Crankshaft Pulley, Double Groove - Chrome Steel

SP8859

Chevy SB Crankshaft Pulley, Triple Groove - Aluminum (Machined, Polished)

SP8958

Chevy SB Crankshaft Pulley, Triple Groove - Chrome Steel

POWER STEERING*

*FITS SMALL & BIG BLOCK CHEVY

SP8846

Chevy Power Steering Pulley, Double Groove - Aluminum (Machined)

SP8848

Chevy Power Steering Pulley, Single Groove - Aluminum (Machined, Polished)

SP8947

Chevy Power Steering Pulley, Double Groove - Chrome Steel

SP8948

Chevy Power Steering Pulley, Single Groove - Chrome Steel

SERPENTINE

SP8982

Chevy SB Serpentine Pulley Set, Aluminum (Machined)

- Must use reverse rotation water pump



SP8854

M P

Chevy SB LWP Water Pump Pulley, Single Groove



SP8864

M

Chevy SB LWP Water Pump Nose Pulley



SP8855

M

Chevy SB LWP Crankshaft Pulley, Single Groove



SP8857

M P

Chevy SB LWP Crankshaft Pulley, Double Groove



SP8859

M P

Chevy SB LWP Crankshaft Pulley, Triple Groove



SP8958

CH

Chevy SB LWP Crankshaft Pulley, Triple Groove



SP8846

M

Chevy Power Steering Pulley, Double Groove



SP8982

M

Chevy SB LWP Serpentine Pulley Set

**SP8850**

M P

Chevy SB SWP Water Pump Pulley,
Single Groove

**SP8852**

M P

Chevy SB SWP Water Pump Pulley,
Double Groove

**SP8863**

M P

Chevy SB SWP Water Pump
Nose Pulley

**SP8853**

M P

Chevy SB SWP Crankshaft Pulley,
Double Groove

**SP8963**

CH

Chevy SB SWP Crankshaft Pulley,
Triple Groove

**SP8848**

M P

Chevy Power Steering Pulley,
Single Groove

**SP8947**

CH

Chevy Power Steering Pulley,
Double Groove

**SP8980**

M

Chevy SB SWP Serpentine Pulley Set

CHEVY SMALL BLOCK SHORT WATER PUMP

WATER PUMP

SP8850

Chevy SB Water Pump Pulley, Single
Groove - Aluminum (Machined, Polished)

SP8852

Chevy SB Water Pump Pulley, Double
Groove - Aluminum (Machined, Polished)

SP8863

Chevy SB Water Pump Nose Pulley
Aluminum (Machined, Polished)

CRANKSHAFT

SP8851

Chevy SB Crankshaft Pulley, Single
Groove - Aluminum (Machined, Polished)

SP8951

Chevy SB Crankshaft Pulley,
Single Groove - Chrome Steel

SP8853

Chevy SB Crankshaft Pulley, Double
Groove - Aluminum (Machined, Polished)

SP8953

Chevy SB Crankshaft Pulley,
Double Groove - Chrome Steel

SP8858

Chevy SB Crankshaft Pulley, Triple
Groove - Aluminum (Machined, Polished)

SP8963

Chevy SB Crankshaft Pulley,
Triple Groove - Chrome Steel

POWER STEERING*

*FITS SMALL & BIG BLOCK CHEVY

SP8846

Chevy Power Steering Pulley,
Double Groove - Aluminum (Machined)

SP8848

Chevy Power Steering Pulley, Single
Groove - Aluminum (Machined, Polished)

SP8947

Chevy Power Steering Pulley,
Double Groove - Chrome Steel

SP8948

Chevy Power Steering Pulley,
Single Groove - Chrome Steel

SERPENTINE

SP8980

Chevy SB Serpentine Pulley Set,
Aluminum (Machined)
- *Must use reverse rotation water pump*

CHEVY BIG BLOCK LONG WATER PUMP

WATER PUMP

SP8838

Chevy BB Water Pump Pulley,
Double Groove - Aluminum (Machined)

SP8960

Chevy BB Water Pump Pulley,
Double Groove - Chrome Steel

CRANKSHAFT

SP8839

Chevy BB Crankshaft Pulley,
Triple Groove - Aluminum (Machined)

SP8961

Chevy BB Crankshaft Pulley,
Triple Groove - Chrome Steel

POWER STEERING*

REFER TO PAGE 89 OR 90

CHEVY BIG BLOCK SHORT WATER PUMP

WATER PUMP

SP8840

Chevy BB Water Pump Pulley,
Single Groove - Aluminum (Machined)

SP8842

Chevy BB Water Pump Pulley, Double
Groove - Aluminum (Machined, Polished)

SP8964

Chevy BB Water Pump Pulley, Double
Groove, Vented Style - Chrome Steel

CRANKSHAFT

SP8841

Chevy BB Crankshaft Pulley, Single
Groove - Aluminum (Machined)

SP8966

Chevy BB Crankshaft Pulley,
Single Groove - Chrome Steel

SP8843

Chevy BB Crankshaft Pulley, Double
Groove - Aluminum (Machined, Polished)

SP8965

Chevy BB Crankshaft Pulley,
Double Groove - Chrome Steel

SP8849

Chevy BB Crankshaft Pulley, Triple
Groove - Aluminum (Machined, Polished)

POWER STEERING*

REFER TO PAGE 89 OR 90



SP8960

CH

Chevy BB LWP Water Pump Pulley,
Double Groove



SP8961

CH

Chevy BB LWP Crankshaft Pulley,
Triple Groove



SP8840

M

Chevy BB SWP Water Pump Pulley,
Single Groove



SP8842

M P

Chevy BB SWP Water Pump Pulley,
Double Groove



SP8841

M

Chevy BB SWP Crankshaft Pulley,
Single Groove



SP8966

CH

Chevy BB SWP Crankshaft Pulley,
Single Groove



SP8843

M P

Chevy BB SWP Crankshaft Pulley,
Double Groove



SP8849

M P

Chevy BB SWP Crankshaft Pulley,
Triple Groove

**SP8970**

Ford SB Water Pump Pulley,
Single Groove

CH

**SP8975**

Ford SB Water Pump Pulley,
Double Groove

CH

**SP8973**

Ford SB Water Pump Pulley,
Triple Groove

CH

**SP8971**

Ford SB Crankshaft Pulley,
Single Groove

CH

**SP8974**

Ford SB Crankshaft Pulley,
Double Groove

CH

**SP8972**

Ford SB Crankshaft Pulley,
Triple Groove

CH

FORD SMALL BLOCK**WATER PUMP****SP8970**

Ford SB Water Pump Pulley, Single
Groove - Chrome Steel

SP8975

Ford SB Water Pump Pulley,
Double Groove - Chrome Steel

SP8973

Ford SB Water Pump Pulley,
Triple Groove - Chrome Steel

CRANKSHAFT**SP8971**

Ford SB Crankshaft Pulley,
Single Groove - Chrome Steel

SP8974

Ford SB Crankshaft Pulley, Double
Groove - Chrome Steel

SP8972

Ford SB Crankshaft Pulley, Triple Groove
Chrome Steel

INTAKE MANIFOLDS



Four corner water ports



Special manifold adapters



Big gains from 1,500 - 6,500 RPM



Open area under the plenum



82025
Chevy SB V8 Intake Manifold
Dual Plane Air Gap

TSP's High rise air gap performance dual plane intake manifolds performs best with high lift cams, tubular headers, and high flow heads. With large plenums and open runners that are raised above the valley allow for a cooler intake charge that will products more power. These manifolds give more top end power than a stock dual plan manifold. Performance gains from 1,500-6,500 rpm make this manifold a great addition to your bracket car or weekend racer. Manifold features four corner water outlets, nitrous bosses, and dual distributor hold downs.

INTAKE MANIFOLDS

CHEVY SMALL BLOCK INTAKE MANIFOLD

82000

Chevy SB V8 Intake Manifold
Stock Dual Plane
Polished

82001

Chevy SB V8 Intake Manifold
Stock Dual Plane
Black, Satin

82025

Chevy SB V8 Intake Manifold
Dual Plane Air Gap
Polished

82026

Chevy SB V8 Intake Manifold
Dual Plane Air Gap
Black, Satin

CHEVY BIG BLOCK INTAKE MANIFOLD

83000

Chevy BB V8 Intake Manifold
Stock Dual Plane
Polished

83001

Chevy BB V8 Intake Manifold
Stock Dual Plane
Black, Satin

FORD SMALL BLOCK INTAKE MANIFOLD

84000

Ford SB V8 Intake Manifold Dual Plane
Polished

84001

Ford SB V8 Intake Manifold Dual Plane
Satin

84025

Ford SB V8 Intake Manifold
Dual Plane Air Gap
Polished

84026

Ford SB V8 Intake Manifold
Dual Plane Air Gap
Satin



82000

Chevy SB V8 Stock Dual Plane



82001

Chevy SB V8 Stock Dual Plane



83000

Chevy BB V8 Stock Dual Plane



83001

Chevy BB V8 Stock Dual Plane



84000

Ford SB V8 Dual Plane



84001

Ford SB V8 Dual Plane



84025

Ford SB V8 Dual Plane Air Gap



84026

Ford SB V8 Dual Plane Air Gap



HARMONIC BALANCERS



30000

Chevy SB 350, 6-3/4" SFI Certified Harmonic Balancer

sfi SFI FOUNDATION INC. This Mfr. Certifies That This Product Meets 18.1 Read Mfr. Instructions Before Install

SPEC 18.1
A 937510

TSP's Harmonic Balancers provide unbeatable performance and durability. Utilizing superior internal design and accurate balancing, they are built to handle your high-performance engine with ease. Also featured are easy-to-read, white on black timing marks for simple installation. They are precisely machined for a perfect fit and are available for many applications.



30002



Chevy SB 350, 8" SFI Certified Harmonic Balancer



30003



Chevy SB 400, 8" SFI Certified Harmonic Balancer



30004



Chevy BB 396/427, 8" SFI Certified Harmonic Balancer



31004



Chevy BB 396/427, 8" SFI Certified Harmonic Balancer



30005



Chevy BB 454/502, 8" SFI Certified Harmonic Balancer



30006

Ford SB Early, 6.4" Harmonic Balancer



30007

Ford SB Late, 6.4" Harmonic Balancer



30008

Ford 429, 6.7" Harmonic Balancer

HARMONIC BALANCERS

30000

Chevy SB 350, 6-3/4" SFI Certified Harmonic Balancer
Satin

31000

Chevy SB 350, 6-3/4" SFI Certified Harmonic Balancer
Gloss

30001

Chevy SB 400, 6-3/4" SFI Certified Harmonic Balancer
Satin

30002

Chevy SB 350, 8" SFI Certified Harmonic Balancer
Satin

30003

Chevy SB 400, 8" SFI Certified Harmonic Balancer
Satin

30004

Chevy BB 396/427, 8" SFI Certified Harmonic Balancer
Satin

31004

Chevy BB 396/427, 8" SFI Certified Harmonic Balancer
Gloss

30005

Chevy BB 454/502, 8" SFI Certified Harmonic Balancer
Satin

30006

Ford SB Early, 6.4" Harmonic Balancer
Satin

30007

Ford SB Late, 6.4" Harmonic Balancer
Satin

30008

Ford 429, 6.7" Harmonic Balancer
Satin

VALVE COVERS



Clears most aftermarket rockers



TIG Welded



CNC Flange or Rail



6061-T6 Aluminum construction



JM8081-5
GM LS Aluminum Fabricated Valve Cover,
Center Bolt without Coil Mounts, Oil Filler
Hole

TSP's Valve Covers are constructed of high-quality materials and are available for any look and application. We've got cast aluminum valve covers for the classic or retro look and fabricated aluminum for racing. Our fabricated covers feature CNC-machined rails and are completely TIG welded. They offer excellent stability and valve train clearance along with great looks. So regardless of the application, we've got you "covered."

VALVE COVERS

GM LS VALVE COVER

JM8081-5

GM LS Aluminum Fabricated Valve Cover, Center Bolt without Coil Mounts, Oil Filler Hole
Black, Polished, Clear Anodized

JM8081-6

GM LS Aluminum Fabricated Valve Cover, Center Bolt with Coil Mounts, Oil Filler Hole
Black, Polished, Clear Anodized

JM8081-7

GM LS Aluminum Fabricated Coil Cover, Center Bolt with Billet Oil Filler Neck, Patent # D735759
Black, Polished, Clear Anodized

CHEVY VALVE COVER

JM8072-2

Chevy SB Aluminum Tall Fabricated Valve Cover, Center Bolt without Breather Hole
Polished, Clear Anodized

JM8091-2

Chevy SB Aluminum Tall Fabricated Valve Cover, Long Bolt without Breather Hole
Polished, Clear Anodized

JM8091-3

Chevy SB Aluminum Tall Fabricated Valve Cover, Short Bolt without Breather Hole
Polished, Clear Anodized

JM8091-7

Chevy SB Aluminum Tall Fabricated Valve Cover, Long Bolt With Breather Hole
Polished, Clear Anodized

JM8091-8

Chevy SB Aluminum Tall Fabricated Valve Cover, Short Bolt with Breather Hole
Black, Polished, Clear Anodized

JM8092-2

Chevy BB Aluminum Tall Fabricated Valve Cover, Long Bolt without Breather Hole
Polished, Clear Anodized



JM8081-6



Chevy LS Aluminum Fabricated Center Bolt with Coil Mounts



JM8081-7



Chevy LS Aluminum Fabricated Center Bolt, Patent #D735759



JM8072-2



Chevy SB Aluminum Tall Fabricated Center Bolt without Breather Hole



JM8091-2



Chevy SB Aluminum Tall Fabricated Long Bolt without Breather Hole



JM8091-3



Chevy SB Aluminum Tall Fabricated Short Bolt without Breather Hole



JM8091-7



Chevy SB Aluminum Tall Fabricated Long Bolt with Breather Hole



JM8091-8



Chevy SB Aluminum Tall Fabricated Short Bolt with Breather Hole



JM8092-2



Chevy BB Aluminum Tall Fabricated Long Bolt without Breather Hole

CHEVY VALVE COVER

JM8092-3

Chevy BB Aluminum Tall Fabricated Valve Cover, Short Bolt without Breather Hole
Chrome, Polished, Clear Anodized



JM8092-3

CH P CA

Chevy BB Aluminum Tall Fabricated Short Bolt without Breather Hole

JM8092-7

Chevy BB Aluminum Tall Fabricated Valve Cover, Long Bolt with Breather Hole
Polished, Clear Anodized



JM8092-7

P CA

Chevy BB Aluminum Tall Fabricated Long Bolt with Breather Hole

JM8092-8

Chevy BB Aluminum Tall Fabricated Valve Cover, Short Bolt with Breather Hole
Black, Chrome, Polished, Clear Anodized



JM8092-8

BK CH P CA

Chevy BB Aluminum Tall Fabricated Short Bolt with Breather Hole

JM8111-8

Chevy SB Aluminum Tall Die Cast Smooth Valve Cover, Short Bolt with Breather Hole
Polished



JM8111-8

P

Chevy SB Aluminum Tall Die Cast Smooth Short Bolt with Breather Hole

JM8112-8

Chevy BB Aluminum Tall Die Cast Smooth Valve Cover, Short Bolt with Breather Hole
Polished



JM8112-8

P

Chevy BB Aluminum Tall Die Cast Smooth Short Bolt with Breather Hole

JM8501-6

Chevy SB Aluminum Tall Die Cast Finned Valve Cover, Center Bolt with Breather Hole
Polished



JM8501-6

P

Chevy SB Aluminum Tall Die Cast Finned Center Bolt with Breather Hole

JM8501-8

Chevy SB Aluminum Tall Die Cast Finned Valve Cover, Short Bolt with Breather Hole
Polished



JM8501-8

P

Chevy SB Aluminum Tall Die Cast Finned Short Bolt with Breather Hole

JM8502-8

Chevy BB Aluminum Tall Die Cast Finned Valve Cover, Short Bolt with Breather Hole
Polished



JM8502-8

P

Chevy BB Aluminum Tall Die Cast Finned Short Bolt with Breather Hole

FORD VALVE COVER



JM8041-7

P CA

Ford SB Aluminum Tall Fabricated Tapered Long Bolt with Breather Hole



JM8041-8

P CA

Ford SB Aluminum Tall Fabricated Tapered Short Bolt with Breather Hole



JM8093-2

P CA

Ford SB Aluminum Tall Fabricated Long Bolt without Breather Hole



JM8093-3

P CA

Ford SB Aluminum Tall Fabricated Short Bolt without Breather Hole



JM8093-7

P CA

Ford SB Aluminum Tall Fabricated Long Bolt with Breather Hole



JM8093-8

P CA

Ford SB Aluminum Tall Fabricated Short Bolt with Breather Hole



JM8094-2

P CA

Ford BB Aluminum Tall Fabricated Long Bolt without Breather Hole



JM8094-3

P CA

Ford BB Aluminum Tall Fabricated Short Bolt without Breather Hole

JM8041-7

Ford SB 5.0L EFI Aluminum Tall Fabricated Tapered Valve Cover, Long Bolt with Breather Hole Polished, Clear Anodized

JM8041-8

Ford SB 5.0L EFI Aluminum Tall Fabricated Tapered Valve Cover, Short Bolt with Breather Hole Polished, Clear Anodized

JM8093-2

Ford SB Aluminum Tall Fabricated Valve Cover, Long Bolt without Breather Hole Polished, Clear Anodized

JM8093-3

Ford SB Aluminum Tall Fabricated Valve Cover, Short Bolt without Breather Hole Polished, Clear Anodized

JM8093-7

Ford SB Aluminum Tall Fabricated Valve Cover, Long Bolt with Breather Hole Polished, Clear Anodized

JM8093-8

Ford SB Aluminum Tall Fabricated Valve Cover, Short Bolt with Breather Hole Polished, Clear Anodized

JM8094-2

Ford BB Aluminum Tall Fabricated Valve Cover, Long Bolt without Breather Hole Polished, Clear Anodized

JM8094-3

Ford BB Aluminum Tall Fabricated Valve Cover, Short Bolt without Breather Hole Polished, Clear Anodized

FORD VALVE COVER

JM8094-7

Ford BB Aluminum Tall Fabricated Valve Cover, Long Bolt with Breather Hole
Polished, Clear Anodized

JM8094-8

Ford BB Aluminum Tall Fabricated Valve Cover, Short Bolt with Breather Hole
Polished, Clear Anodized

FORD FE VALVE COVER

JM8098-3

Ford FE Aluminum Tall Fabricated Valve Cover, Short Bolt without Breather Hole
Polished, Clear Anodized

JM8098-8

Ford FE Aluminum Tall Fabricated Valve Cover, Short Bolt with Breather Hole
Polished, Clear Anodized

MOPAR VALVE COVER

JM8096-7

Mopar SB Aluminum Tall Fabricated Valve Cover, Long Bolt with Breather Hole
Polished, Clear Anodized

JM8097-7

Mopar BB Aluminum Tall Fabricated Valve Cover, Long Bolt with Breather Hole
Polished, Clear Anodized

JM8097-8

Mopar BB Aluminum Tall Fabricated Valve Cover, Short Bolt with Breather Hole
Polished, Clear Anodized



JM8094-7



Ford BB Aluminum Tall Fabricated Long Bolt with Breather Hole



JM8094-8



Ford BB Aluminum Tall Fabricated Short Bolt with Breather Hole



JM8098-3



Ford FE Aluminum Tall Fabricated Short Bolt without Breather Hole



JM8098-8



Ford FE Aluminum Tall Fabricated Short Bolt with Breather Hole



JM8096-7



Mopar SB Aluminum Tall Fabricated Long Bolt with Breather Hole



JM8097-7



Mopar BB Aluminum Tall Fabricated Long Bolt with Breather Hole



JM8097-8



Mopar BB Aluminum Tall Fabricated Short Bolt with Breather Hole

VALVE COVER GASKETS

CHEVY VALVE COVER GASKET

SP7483

Chevy SB 265-400, 1955-1993
3/16" Cork Valve Cover Gasket

SP7484

Chevy SB 265-400, 1955-1993
3/16" Rubber with Steel Valve Cover Gasket

SP7489

Chevy SB 5.0L-5.7L, 1987-Up
1/8" Black Rubber Valve Cover Gasket

SP6120

Chevy BB 396-502, 1965-1995
1/8" Cork Valve Cover Gasket

SP6121

Chevy BB 396-502, 1965-1995
3/16" Rubber with Steel Valve Cover Gasket

FORD VALVE COVER GASKET

SP6122

Ford SB 260-351 Windsor, 1962-1991
3/16" Cork Valve Cover Gasket

SP6123

Ford SB 260-351 Windsor, 1962-1991
3/16" Rubber with Steel Valve Cover Gasket

SP6112

Ford P/U Truck (L/A) 360-390, 1968-1979,
Ford Car 1961-1971
3/16" Rubber with Steel Valve Cover Gasket



SP7483

Chevy SB 265-400, 1955-1993
3/16" Cork

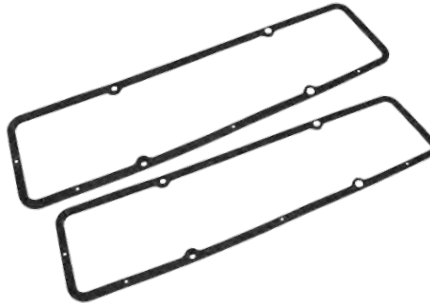

SP7484

Chevy SB 265-400, 1955-1993
3/16" Rubber with Steel

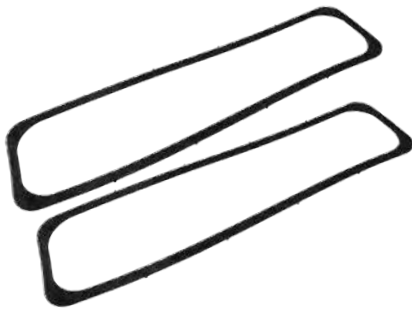

SP7489

Chevy SB 5.0L-5.7L, 1987-Up
1/8" Black Rubber



SP6120

Chevy BB 396-502, 1965-1995
1/8" Cork

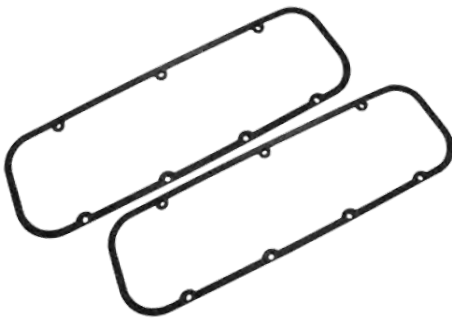

SP6121

Chevy BB 396-502, 1965-1995
3/16" Rubber with Steel



SP6122

Ford SB 260-351 Windsor, 1962-1991
3/16" Cork

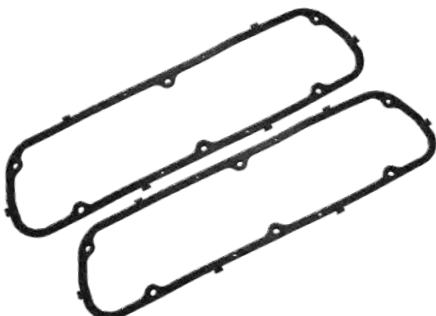

SP6123

Ford SB 260-351 Windsor, 1962-1991
3/16" Rubber with Steel

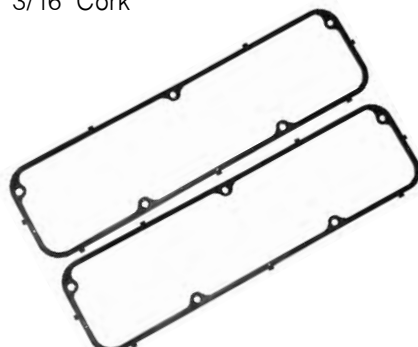

SP6112

Ford Truck 360-390, 1968-1979, Ford Car 1961-1971
3/16" Rubber with Steel

FORD VALVE COVER GASKET

SP6111

Ford 351 Cleveland & 400M 1970-1982 Car & Light Duty Truck 3/16" Rubber with Steel Valve Cover Gasket

SP6124

Ford BB 429-460, 1968-1987 Car & Truck 3/16" Cork Valve Cover Gasket

SP6113

Ford BB 429-460, 1968-1987 Car & Truck 3/16" Rubber with Steel Valve Cover Gasket

CHRYSLER VALVE COVER GASKET

SP6114

Chrysler 318-340-360, 1957-1989 3/16" Rubber with Steel Valve Cover Gasket

SP6115

Chrysler 383-440 Wedge, 1959-1978 3/16" Rubber with Steel Valve Cover Gasket

OLDSMOBILE VALVE COVER GASKET

SP6110

Oldsmobile 260-307-330-350-400-403-425-455, 1964-1990 3/16" Rubber with Steel Valve Cover Gasket



SP6111

Ford 351 Cleveland & 400M, 1970-1982 3/16" Rubber with Steel



SP6124

Ford BB 429-460, 1968-1987 3/16" Cork



SP6113

Ford BB 429-460, 1968-1987 3/16" Rubber with Steel

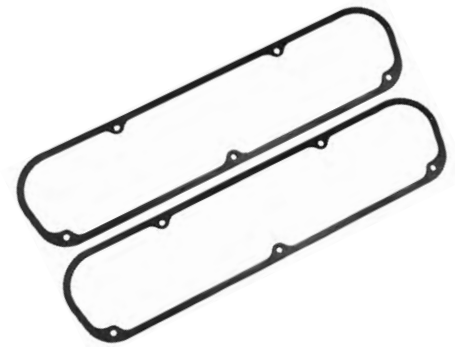

SP6114

Chrysler 318-340-360, 1957-1989 3/16" Rubber with Steel

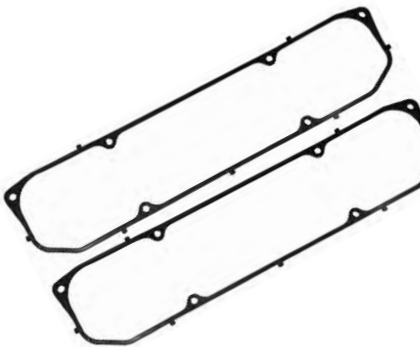

SP6115

Chrysler 383-440 Wedge, 1959-1978 3/16" Rubber with Steel

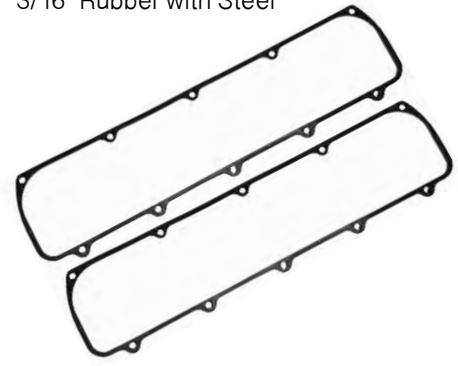

SP6110

Oldsmobile 260-455, 1964-1990 3/16" Rubber with Steel

DIFFERENT VALVE COVER GASKET MATERIAL



CORK



RUBBER WITH STEEL



BLACK RUBBER



SP8489

Plain Polished Aluminum Push-in Breather with 3/4" Neck PCV Valve



SP8486

Oval Finned Polished Aluminum Push-in Breather



SP8487

Oval Finned Polished Aluminum Push-in Breather with PCV Valve



SP7187

High Performance Washable Push-in Breather, 2" Tall without Lip



SP7198

High Performance Washable Push-in Breather



SP7192

High Performance Washable Push-in Breather, 2" Short



SP7177

High Performance Washable Push-in Breather, Fits any 1" Hole



SP7191

High Performance Washable Push-in Breather with Shield, Fits any 1-1/4" Hole

PUSH-IN BREATHERS

SP8489

Plain Polished Aluminum Push-in Breather with 3/4" Neck PCV Valve

SP8486

Oval Finned Polished Aluminum Push-in Breather

**Available in Black Finish*

SP8487

Oval Finned Polished Aluminum Push-in Breather with PCV Valve

**Available in Black Finish*

SP7187

High Performance Washable Push-in Breather, 2" Tall without Lip

SP7198

High Performance Washable Push-in Breather, Fits any 1-1/4" Hole

SP7192

High Performance Washable Push-in Breather, 2" Short, Fits any 1-1/4" Hole

SP7177

High Performance Washable Push-in Breather, Fits any 1" Hole

SP7191

High Performance Washable Push-in Breather with Shield, Fits any 1-1/4" Hole

HIGH PERFORMANCE WASHABLE BREATHERS

SP7181
High Performance Washable Clamp-On Breather, Fits 1-3/8" Tube

SP7180
High Performance Washable Clamp-On Breather with Shield, Fits 1-3/8" Tube

SP7188
High Performance Washable Clamp-On Breather, Fits 1-1/2" Tube

SP7186
High Performance Washable Clamp-On Breather with Shield, Fits 1-1/2" Tube

OIL PLUGS & CAP

SP7490
Push-In Oil Filler Plug (No Logo)

SP7184
Push-In Plug (No Logo)

SP7482-0
Push-In Plug (with Oil Logo)

SP7257
Twist-On OEM Style Cap



SP7181
High Performance Washable Clamp-On Breather, Fits 1-3/8" Tube



SP7180
High Performance Washable Clamp-On Breather with Shield, Fits 1-3/8" Tube



SP7188
High Performance Washable Clamp-On Breather, Fits 1-1/2" Tube



SP7186
High Performance Washable Clamp-On Breather with Shield, Fits 1-1/2" Tube



SP7490
Push-In Oil Filler Plug (No Logo)



SP7184
Push-In Plug (No Logo)



SP7482-0
Push-In Plug (With Oil Logo)



SP7257
Twist-On OEM Style Cap



SP7148

Chrome Steel 4" Plain "Mini"
Air Cleaner, Paper Kit, 3-1/2" Height



SP7151

Chrome Steel 4" Deep Dish "Mini"
Air Cleaner, Paper Kit, 3-1/4" Height



SP7147

Chrome Steel 4" Louvered "Mini"
Air Cleaner, Paper Kit, 3-1/8" Height



SP4355

Chrome Steel 6" Muscle Car
Air Cleaner, Paper Kit, 2-7/8" Height



SP4360

Chrome Steel 10" Muscle Car
Air Cleaner, Paper Kit, 3-1/2" Height

AIR CLEANER KITS

SP7148

Chrome Steel 4" Plain "Mini" Air Cleaner
with Paper Kit, 3-1/2" Height

SP7151

Chrome Steel 4" Deep Dish "Mini"
Air Cleaner with Paper Kit, 3-1/4" Height

SP7147

Chrome Steel 4" Louvered "Mini"
Air Cleaner with Paper Kit, 3-1/8" Height

SP4355

Chrome Steel 6" Muscle Car Air Cleaner
with Paper Kit, 2-7/8" Height

SP4360

Chrome Steel 10" Muscle Car
Air Cleaner with Paper Kit, 3-1/2" Height

OIL PANS

SP8442

Chevy SB 265-350, 1955-1979
4-QT Rear Sump Finned Aluminum Oil
Pan, Driver Side Dipstick
Polished, Black

SP8445

Ford SB 260-302, 1962-1995
4-QT Front Sump Finned Aluminum Oil
Pan, Passenger Side Dipstick
Polished

SP7442

Chevy SB 283-400, 1957-1974
4-QT Rear Sump Steel Oil Pan,
Driver Side Dipstick
Chrome, Black, Orange, Zinc, Unplated

SP7443

Chevy SB 305-350, 1967-1993
4-QT Rear Sump Steel Oil Pan,
Passenger Side Dipstick
Chrome, Zinc, Unplated

SP7441

Chevy SB 305-350, 1986-Up
4-QT Rear Sump Steel Oil Pan,
Passenger Side Dipstick
Chrome, Zinc, Unplated

SP7475

Chevy SB 305-350, 1967-1993
4-QT Rear Sump Steel Oil Pan,
Passenger Side Dipstick
Black

SP7480

Chevy SB 283-350, 1962-1967
6-QT Rear Sump Steel Oil Pan
Unplated

SP7430

Chevy SB 283-400, 1957-1976
7-QT Rear Sump Steel Oil Pan
Chrome



SP8442

Chevy SB 265-350, 1955-1979
Rear Sump Aluminum Oil Pan



SP8445

Ford SB 260-302, 1962-1995
Front Sump Aluminum Oil Pan



SP7442

Chevy SB 283-400, 1957-1974
Rear Sump Steel Oil Pan



SP7443

Chevy SB 305-350, 1967-1993
Rear Sump Steel Oil Pan



SP7441

Chevy SB 305-350, 1986-Up
Rear Sump Steel Oil Pan



SP7475

Chevy SB 305-350, 1967-1993
Rear Sump Steel Oil Pan



SP7480

Chevy SB 283-350, 1962-1967
Rear Sump Steel Oil Pan



SP7430

Chevy SB 283-400, 1957-1976
Rear Sump Steel Oil Pan

**SP7435**

Chevy SB 283-400, 1957-1976
Rear Sump Steel Oil Pan

**SP7444**

Chevy BB 396-454, 1965-1976
Rear Sump Steel Oil Pan

**SP7432**

Chevy BB 396-454, 1965-1976
Rear Sump Steel Oil Pan

**SP7437**

Chevy BB 396-454, 1965-1976
Rear Sump Steel Oil Pan

**SP7445**

Ford SB 260-302, 1962-1995
Front Sump Steel Oil Pan

**SP7457**

Ford SB 302 (5.0L), 1985-1993
Mustang Dual Sump Steel Oil Pan

**SP7454**

Ford SB 351 Cleveland, 351M, 400,
1970-1979 Front Sump Steel Oil Pan

**SP7452**

Ford 351 Windsor, 1969-1991
Front Sump Steel Oil Pan

SP7435

Chevy SB 283-400, 1957-1976
7-QT Rear Sump Steel Oil Pan
Orange

SP7444

Chevy BB 396-454, 1965-1976
4-QT Rear Sump Steel Oil Pan,
Passenger Side Dipstick
Chrome, Black, Zinc, Unplated

SP7432

Chevy BB 396-454, 1965-1976
6-QT Rear Sump Steel Oil Pan,
Passenger Side Dipstick
Chrome

SP7437

Chevy BB 396-454, 1965-1976
6-QT Rear Sump Steel Oil Pan,
Passenger Side Dipstick
Orange

SP7445

Ford SB 260-302, 1962-1995
4-QT Front Sump Steel Oil Pan,
Timing Cover Dipstick
Chrome, Zinc, Unplated

SP7457

Ford SB 302 (5.0L), 1985-1993 Mustang
4-QT Dual Sump Steel Oil Pan
Chrome, Unplated

SP7454

Ford SB 351 Cleveland, 351M, 400,
1970-1979 4-QT Front Sump Steel
Oil Pan
Chrome, Zinc, Unplated

SP7452

Ford 351 Windsor, 1969-1991
4-QT Front Sump Steel Oil Pan,
Timing Cover Dipstick
Chrome, Zinc, Unplated

SP7474

Ford SB 260-302, 1962-1995
7-QT Front Sump Steel Oil Pan,
Timing Cover Dipstick
Zinc

SP7450

Ford BB 352-428, 1958-1970
4-QT Front Sump Steel Oil Pan,
Timing Cover Dipstick
Chrome, Zinc, Unplated

SP7451

Ford BB 429-460, 1968-1978
4-QT Front Sump Steel Oil Pan,
Timing Cover Dipstick
Chrome, Zinc, Unplated

SP7446

Mopar 273-340, 1964-1973
4-QT Front to Center Sump Steel
Oil Pan, Timing Cover Dipstick
Chrome, Zinc

SP7477

Mopar Early Hemi 331-392, 1951-1958
5-QT Rear Sump Steel Oil Pan,
Unplated

SP7447

Mopar 360, 1971-1980
4-QT Front to Center Sump Steel
Oil Pan, Timing Cover Dipstick
Chrome, Zinc

SP7456

Mopar 361-440, 1956-1978
5-QT Front to Center Sump
Steel Oil Pan
Chrome, Unplated

SP7459

Mopar 361-440, 1958-1978
7-QT Front to Center Sump
Steel Oil Pan
Zinc

**SP7474**

Ford SB 260-302, 1962-1995
Front Sump Steel Oil Pan

**SP7450**

Ford BB 352-428, 1958-1970
Front Sump Steel Oil Pan

**SP7451**

Ford BB 429-460, 1968-1978
Front Sump Steel Oil Pan

**SP7446**

Mopar 273-340, 1964-1973
Front to Center Sump Steel Oil Pan

**SP7477**

Mopar Early Hemi 331-392, 1951-1958
Rear Sump Steel Oil Pan

**SP7447**

Mopar 360, 1971-1980
Front To Center Sump Steel Oil Pan

**SP7456**

Mopar 361-440, 1956-1978
Front To Center Sump Steel Oil Pan

**SP7459**

Mopar 361-440, 1958-1978
Front to Center Sump Steel Oil Pan

**SP7458**

Mopar 361-440, 1958-1978
Front to Center Sump Steel Oil Pan

**SP7453**

Oldsmobile 330-455, 1964-1976
Rear Sump Steel Oil Pan

**SP7455**

Pontiac 265-455, 1959-1981
Rear Sump Steel Oil Pan

**SP7420**

Chevy SB Hi-Volume Oil Pan Pick-Up

**SP7414**

Chevy BB, 1965-1976 Standard Volume
Oil Pan Pick-Up

**SP7422**

Chevy BB, 1965-1976 Hi-Volume
Oil Pan Pick-Up

**SP7427**

Ford SB Double Sump Oil Pan Pick-Up

**SP7421**

Ford SB, 1962-1995 Oil Pan Pick-Up

SP7458

Mopar 361-440, 1958-1978
7-QT Front To Center Sump Steel Oil Pan
Unplated

SP7453

Oldsmobile 330-455, 1964-1976
4-QT Rear Sump Steel Oil Pan,
Chrome, Zinc, Unplated

SP7455

Pontiac 265-455, 1959-1981
4-QT Rear Sump Steel Oil Pan,
Chrome, Zinc, Unplated

OIL PAN PICK-UPS**SP7420**

Chevy SB Hi-Volume Oil Pan Pick-Up
**Will fit 7430, 7435, 7471, 7480X Oil Pan*

SP7414

Chevy BB, 1965-1976 Standard Volume
Oil Pan Pick-Up
**Will fit 7432, 7437 Oil Pan*

SP7422

Chevy BB, 1965-1976 Hi-Volume Oil Pan
Pick-Up
**Will fit 7432, 7437 Oil Pan*

SP7427

Ford SB Double Sump Oil Pan Pick-Up
**Not for Trucks or Vans (302) 5.0L*
**Will fit 7457 Oil Pan*

SP7421

Ford SB, 1962-1995 Oil Pan Pick-Up
**Will fit 7474 Oil Pan*

SP7412

Mopar Hemi Stock 426 1/2" - 14" Threads, 1966-Up Extra Capacity Oil Pan Pick-Up
*Will fit 7458 Oil Pan

SP7411

Mopar B & RB 3/8" - 18" Threads, 1966-Up Extra Capacity Oil Pan Pick-Up
*Will fit 7458 Oil Pan

SP7423

Mopar B & RB 3/8" - 18" Threads, 1966-Up Oil Pan Pick-Up
*Will fit 7459 Oil Pan

OIL PAN GASKETS**SP6105**

Chevy SB 283-350, 1957-1979
Rubber Gasket (2-Piece Rear Main Seal)
Black

SP6106

Chevy SB 305-350, 1980-1985
Rubber Gasket (2-Piece Rear Main Seal)
Black

SP6107

Chevy SB 305-350, 1986-1993
Rubber Gasket (1-Piece Rear Main Seal)
Black

**SP7412**

Mopar Hemi Stock 426, 1966-Up Oil Pan Pick-Up

**SP7411**

Mopar B & RB, 1966-Up Oil Pan Pick-Up

**SP7423**

Mopar B & RB, 1966-Up Oil Pan Pick-Up

**SP6105**

Chevy SB 283-350, 1957-1979
Rubber Gasket

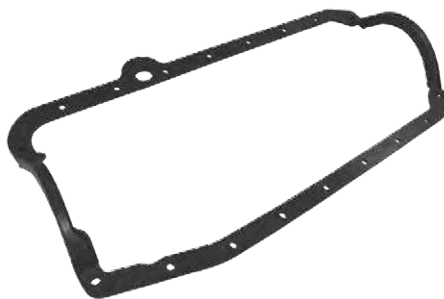
**SP6106**

Chevy SB 305-350, 1980-1985
Rubber Gasket

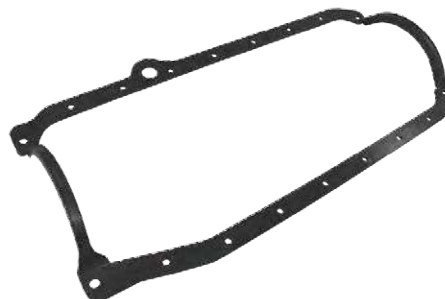
**SP6107**

Chevy SB 305-350, 1986-1993
Rubber Gasket



**Gasket & Drain Plug Included*

SP8491

GM TH350 Finned Aluminum
Transmission Oil Pan



**Gasket & Drain Plug Included*

SP8593

GM TH400 Finned Aluminum
Transmission Oil Pan



**Gasket & Drain Plug Included*

SP8594

GM 700R4 Finned Aluminum
Transmission Oil Pan



SP7680

GM TH350 Transmission Oil Pan
Gasket

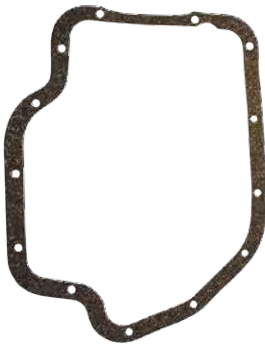

SP7681

GM TH400 Transmission Oil Pan
Gasket



SP7686

GM 700R4 Transmission Oil Pan
Gasket

TRANSMISSION OIL PANS

SP8491

GM TH350 Finned Aluminum
Transmission Oil Pan
Polished, Black

SP8593

GM TH400 Finned Aluminum
Transmission Oil Pan
Polished, Black

SP8594

GM 700R4 Finned Aluminum
Transmission Oil Pan
Polished, Black

TRANSMISSION OIL PAN GASKETS

SP7680

GM TH350 Transmission Oil Pan
Gasket, Cork

SP7681

GM TH400 Transmission Oil Pan
Gasket, Cork

SP7686

GM 700R4 Transmission Oil Pan
Gasket, Cork

MIRRORS

SP8223

4" Stainless Steel Outside Mirror
Swan Neck Style, Stud Mount
2-Piece (Pair)



SP8223

4" Stainless Steel Outside Mirror,
Swan Neck Style



SP8217

4" Stainless Steel Outside Mirror,
Peep Style

SP8217

4" Stainless Steel Outside Mirror
Peep Style, 1-Piece (Single)
**Fits Driver & Passenger Side*

SP8215

9-3/4" Stainless Steel Universal Interior
Rear View Mirror with Day/Night Switch
1-Piece (Single)



SP8215

9-3/4" Stainless Steel Universal Interior
Rear View Mirror with Day/Night Switch



SP8218

5-1/2" Aluminum Ball-Milled Universal
Interior Rear View Mirror

SP8218

5-1/2" Aluminum Ball-Milled Universal
Interior Rear View Mirror
1-Piece (Single)

SP8219

8-1/4" Aluminum Ball-Milled Universal
Interior Rear View Mirror
1-Piece (Single)



SP8219

8-1/4" Aluminum Ball-Milled Universal
Interior Rear View Mirror



SP8236

3" Chrome Aluminum Universal
Window Handles

WINDOW & DOOR HANDLES

SP8236

3" Chrome Aluminum Universal
Window Handles

SP8235

3" Chrome Aluminum Universal
Door Handles



SP8235

3" Chrome Aluminum Universal
Door Handles



SP8228

4-1/4" Chrome Aluminum Universal
Window Handles



SP8227
4-1/4" Chrome Aluminum Universal Door Handles



SP8425
Polished Aluminum Milled Dash Knob

SP8227
4-1/4" Chrome Aluminum Universal Door Handles

POLISHED ALUMINUM KNOBS

SP8425
Polished Aluminum Milled Dash Knob 1/8" Hole

SP8426
Polished Aluminum Milled Gear Shift Knob with 5/16", 1/4" & 3/8" Inserts

SP8427
Polished Aluminum Steering Column Shifter, GM 1967-1994

SP8428
Polished Aluminum Steering Column Dress-Up Kit, GM Cars & Trucks

GAS & BRAKE PEDALS

SP8210
Polished Aluminum Street Rod Firewall Mount Pedal

SP8211
Polished Aluminum Street Rod Firewall Mount Pedal

SP8234
Polished Aluminum Street Rod Floor Mount Pedal



SP8426
Polished Aluminum Milled Gear Shift Knob



SP8427
Polished Aluminum Steering Column Shifter, GM 1967-1994



SP8428
Polished Aluminum Steering Column Dress-Up Kit, GM Cars & Trucks



SP8210
Polished Aluminum Street Rod Firewall Mount Pedal



JM8211
Polished Aluminum Street Rod Firewall Mount Pedal



JM8234
Polished Aluminum Street Rod Floor Mount Pedal

SP7210

Chrome Steel Spoon Style Firewall Mount Pedal



SP7210

Chrome Steel Spoon Style Firewall Mount Pedal

SP8226

Polished Aluminum Firewall Mount Oval Universal Pedal



SP8226

Polished Aluminum Firewall Mount Oval Pedal

SP8220

Chrome Alloy Barefoot Pedal



SP8220

Chrome Alloy Barefoot Pedal

SP8208

Polished Aluminum Gas Pedal



SP8208

Polished Aluminum Gas Pedal

SP8212

Polished Aluminum Street Rod Brake Pedal, 3-1/8" x 2" Manual Transmission



SP8212

Polished Aluminum Street Rod Brake Pedal

SP8213

Polished Aluminum Street Rod Brake Pedal, 4-1/4" x 2-1/2"



SP8213

Polished Aluminum Street Rod Brake Pedal

SP8214

Polished Aluminum Dimmer Pedal



SP8214

Polished Aluminum Dimmer Pedal

SP8221

Chrome Alloy Barefoot Dimmer Pedal



SP8221

Chrome Alloy Barefoot Dimmer Pedal

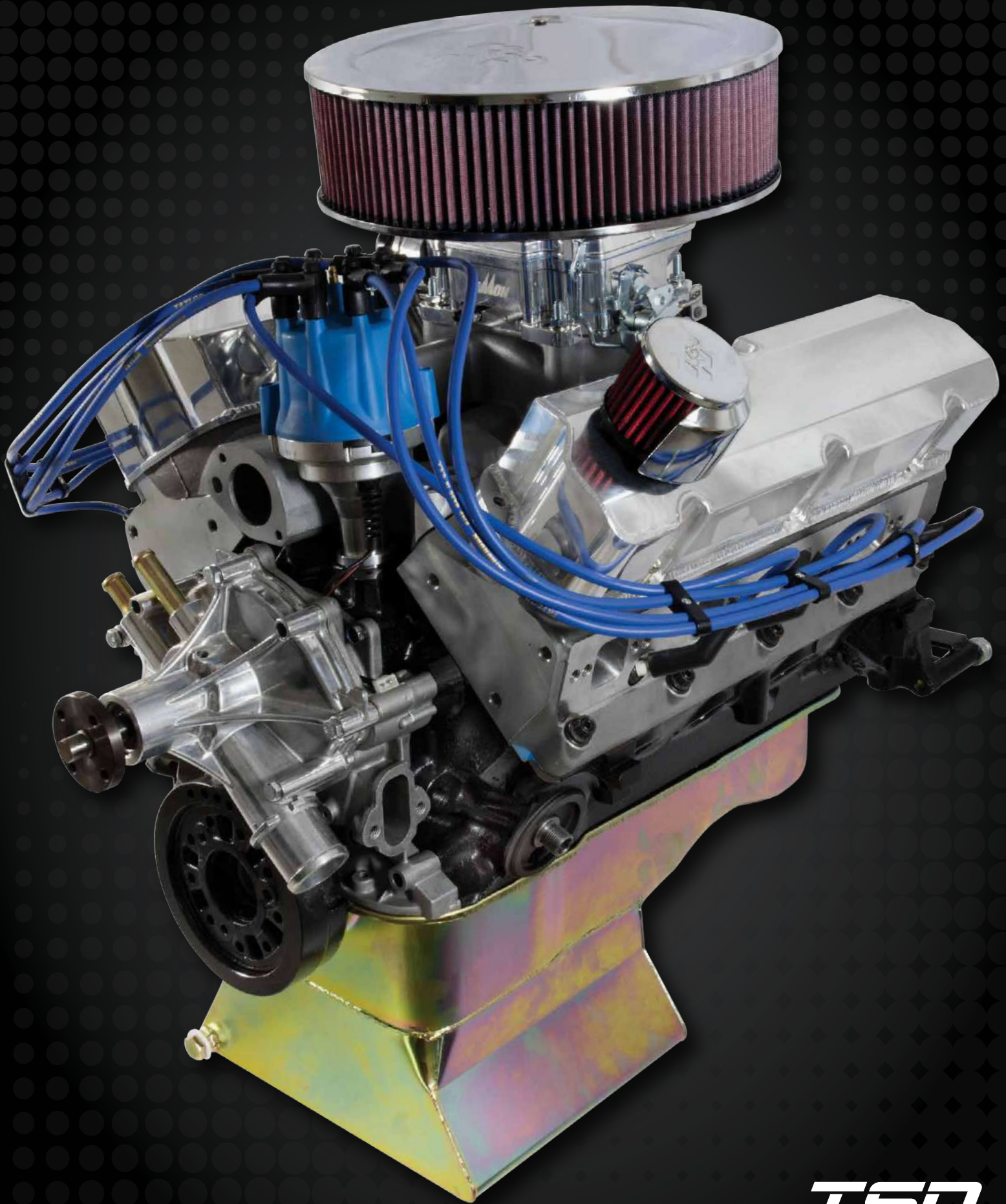

TSP
TO STREET PERFORMANCE

ELECTRIC FUEL PUMP & FILTER MOUNTING BRACKET KIT



JM1040-KT

- Universal In-Line Fuel Pump, In-line Fuel Filter, AN Cross Over Tube, and Dual Pump/Filter Mounting Bracket
- Quick disconnect/ AN /hose barb fittings, and power connection hardware



JM1041-KT

- Universal In-Line Fuel Pump, In-line Fuel Filter, and Pump/Filter Mounting Bracket
- Quick disconnect/ AN /hose barb fittings, and power connection hardware

TSP's Fuel Pump and Filter Mounting Kit was designed for the popular Bosch 044 style electric fuel pump and accompanying fuel filter. Available in black and red, this aluminum bracket offers a clean look and easy installation.



**Fittings Included*

JM1040

BK

Universal Electric EFI Inline Fuel Pump 350 LPH, Bosch 044 Style



JM1019

BK R

Single Fuel Pump Aluminum Mounting Bracket, Bosch 044 Style



JM1020

BK R

Dual Fuel Pump & Fuel Filter Aluminum Mounting Bracket, Bosch 044 Style



JM1021

Aluminum Inline Fuel Filter with 10 Micron Element, -10 AN Inlet/Outlet size
Black, Red

JM1022

Aluminum Inline Fuel Filter with 40 Micron Element, -10 AN Inlet/Outlet size
Black, Red

JM1023

Aluminum Inline Fuel Filter with 100 Micron Element, -10 AN Inlet/Outlet size
Black, Red



JM1023

BK R

Fuel Filter with 100 Micron Element



JM1024

10 Micron Paper Fuel Filter Element

JM1024

10 Micron Paper Fuel Filter Element

JM1025

40 Micron Stainless Steel Fuel Filter Element

JM1026

100 Micron Stainless Steel Fuel Filter Element



JM1026

100 Micron Stainless Steel Fuel Filter Element



JM1059

BK R

EFI Billet Aluminum Fuel Pressure Bypass Regulator 40-75 PSI, -6 AN

JM1027

Inline Fuel Filter Mounting Bracket
Black, Red

JM1059

EFI Billet Aluminum Fuel Pressure Bypass Regulator 40-75 PSI, -6AN
Black, Red

ELECTRIC FUEL PUMPS AND FUEL REGULATORS



JM1044
Electric Carburetor Fuel Pump, 155 GPH



JM1057
Billet Aluminum Fuel Pressure Regulator
5-12 PSI, 3/8" NPT

TSP's Electric Fuel Pumps and Regulators offer reliable performance for anyone who is looking for more than a mechanical pump can offer. Cast from lightweight aluminum, our electric fuel pumps contain high-quality components and low-amp-draw electric motors. Our fuel pressure regulators, which also feature an aluminum body, allow you to fine-tune how much fuel gets to your fuel injection system or carburetor.



JM1042

CH

Electric Carburetor Fuel Pump
115 GPH



JM1043

CH

Electric Carburetor Fuel Pump
130 GPH



JM1044

CH

Electric Carburetor Fuel Pump
155GPH



JM1055

BK CH

Aluminum Fuel Pressure Regulator
1-4 PSI, 3/8" NPT



JM1056

BK CH

Aluminum Fuel Pressure Regulator
5-9 PSI, 3/8" NPT



JM1057

R BK BL CA

Billet Aluminum Fuel Pressure
Regulator 5-12 PSI, 3/8" NPT

ELECTRIC FUEL PUMPS

JM1042

Electric Carburetor Fuel Pump 115GPH
3/8" NPT Inlet/Outlet Port
Chrome

JM1043

Electric Carburetor Fuel Pump 130GPH
3/8" NPT Inlet/Outlet Port
Chrome

JM1044

Electric Carburetor Fuel Pump 155GPH
3/8" NPT Inlet/Outlet Port
Chrome

FUEL REGULATORS

JM1055

Aluminum Fuel Pressure Regulator
1-4 PSI, 3/8" NPT
Black, Chrome

JM1056

Aluminum Fuel Pressure Regulator
5-9 PSI, 3/8" NPT
Black, Chrome

JM1057

Billet Aluminum Fuel Pressure Regulator
5-12 PSI, 3/8" NPT
Red, Black, Blue, Clear Anodized

MECHANICAL FUEL PUMPS



Chrome finish



Adjustable plate for different positioning



Heavy-duty rubber seals



JM1037

Chevy SB V8 Engine Super Flow 6 Valve
Racing Mechanical Fuel Pump

TSP's Mechanical Fuel Pumps are for those who want to upgrade their fuel pump without losing that classic look. Our pumps are cast from lightweight aluminum and given a beautiful, high-quality chrome finish. They've been designed to flow at an improved rate over stock. All of our pumps feature an adjustable rotating plate for a custom-fit to your engine bay and have been given heavy duty rubber seals for optimum leak protection.

**JM1003**

BK CH

Chevy SB 262-400 Mechanical Fuel Pump, 6 PSI

**JM1004**

BK CH

Chevy BB 396-454 Mechanical Fuel Pump, 6 PSI

**JM1005**

BK CH

Chrysler SB 273-360 Mechanical Fuel Pump, 6 PSI

**JM1006**

BK CH

Chrysler BB 361-440 Mechanical Fuel Pump, 6 PSI

**JM1007**

BK CH

Ford SB 221-351 Windsor Mechanical Fuel Pump, 6 PSI

**JM1008**

BK CH

Ford FE 352-428 Mechanical Fuel Pump, 6 PSI

**JM1009**

BK CH

Ford 351 Cleveland Mechanical Fuel Pump, 6 PSI

**JM1010**

BK CH

Ford BB 429/460 Mechanical Fuel Pump, 6 PSI

MECHANICAL FUEL PUMPS

2 VALVE: 80 GPH

JM1003

Chevy SB 262-400 Mechanical Fuel Pump, V8 Engine, 6 PSI
1/4" NPT Inlet/Outlet
Black, Chrome

JM1004

Chevy BB 396-454 Mechanical Fuel Pump, V8 Engine, 6 PSI
1/4" NPT Inlet/Outlet
Black, Chrome

JM1005

Chrysler SB 273-360 Mechanical Fuel Pump, V8 Engine, 6 PSI
1/4" NPT Inlet/Outlet
Black, Chrome

JM1006

Chrysler BB 361-440 Mechanical Fuel Pump, V8 Engine, 6 PSI
1/4" NPT Inlet/Outlet
Black, Chrome

JM1007

Ford SB 221-351 Windsor Mechanical Fuel Pump, V8 Engine, 6 PSI
1/4" NPT Inlet/Outlet
Black, Chrome

JM1008

Ford FE 352-428 Mechanical Fuel Pump, V8 Engine, 6 PSI
1/4" NPT Inlet/Outlet
Black, Chrome

JM1009

Ford 351 Cleveland Mechanical Fuel Pump, V8 Engine, 6 PSI 1/4" NPT Inlet/Outlet
Black, Chrome

JM1010

Ford BB 429/460 Mechanical Fuel Pump, V8 Engine, 6 PSI
1/4" NPT Inlet/Outlet
Black, Chrome

JM1011

Oldsmobile 215-455 Mechanical Fuel Pump, V8 Engine, 6 PSI
1/4" NPT Inlet/Outlet
Black, Chrome

JM1012

Pontiac 301-455 Mechanical Fuel Pump, V8 Engine, 6 PSI
1/4" NPT Inlet/Outlet
Black, Chrome

6 VALVE: 110 GPH

JM1015

Chevy SB 262-400 Racing Mechanical Fuel Pump, V8 Engine, 7.5 PSI
3/8" NPT Inlet/Outlet
Black, Chrome

JM1016

Chevy SB 262-400 Racing Mechanical Fuel Pump, V8 Engine, 9 PSI
1/2" NPT Inlet/Outlet
Black, Chrome

6 VALVE: 130+ GPH

JM1037

Chevy SB Super Flow Racing Mechanical Fuel Pump, V8 Engine, 12-16 PSI 1/2" NPT Inlet/Outlet
Black, Chrome
**Requires Fuel Regulator*

FITTINGS

JM1066

Mechanical Fuel Pump Brass Fitting Kit

MECHANICAL FUEL BLOCK OFF PLATES

SP7605

Chevy SB Mechanical Fuel Pump Block Off Plate with Gasket
Chrome Steel, Raw Steel

SP8511

Chevy SB Mechanical Fuel Pump Block Off Plate with Gasket
Die Cast Aluminum



JM1011

BK CH

Oldsmobile 215-455 Mechanical Fuel Pump, 6 PSI



JM1012

BK CH

Pontiac 304-455 Mechanical Fuel Pump, 6 PSI



JM1015

BK CH

Chevy SB 262-400 Racing Mechanical Fuel Pump, 7.5 PSI



JM1016

BK CH

Chevy SB 262-400 Racing Mechanical Fuel Pump, 9 PSI



JM1037

BK CH

Chevy SB Super Flow Racing Mechanical Fuel Pump, 12-16 PSI



JM1066

Mechanical Fuel Pump Brass Fitting Kit

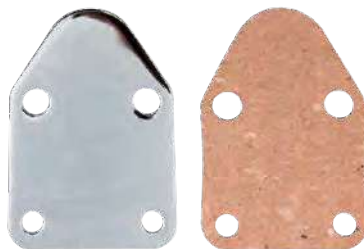

SP7605

Chevy SB Mechanical Fuel Pump Block Off Plate with Gasket

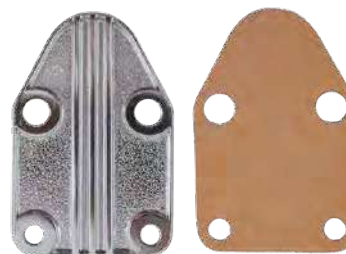

SP8511

Chevy SB Mechanical Fuel Pump Block Off Plate with Gasket

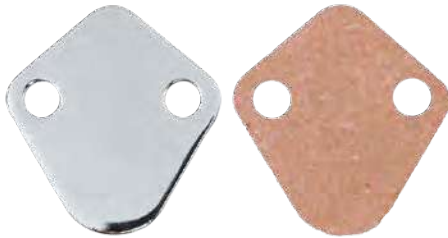

SP7604

Chevy BB Mechanical Fuel Pump
Block off Plate with Gasket



SP7631

Chevy SB Mechanical Fuel Pump
Block off Plate "EGR"

SP7604

Chevy BB Mechanical Fuel Pump
Block Off Plate with Gasket
Chrome Steel, Raw Steel

SP7631

Chevy SB Mechanical Fuel Pump
Block Off Plate "EGR"
Chrome Steel

FUEL PRESSURE GAUGES

JM1017

Liquid Filled Fuel Pressure Gauge
0-15 PSI, 1/8" NPT, 1.5" Diameter

JM1018

Liquid Filled Fuel Pressure Gauge
0-100 PSI, 1/8" NPT, 1.5" Diameter



JM1017

Liquid Filled Fuel Pressure Gauge
0-15 PSI, 1/8" NPT, 1.5" Diameter



JM1018

Liquid Filled Fuel Pressure Gauge
0-100 PSI, 1/8" NPT, 1.5" Diameter

THROTTLE CABLE BRACKET

JM3101

Aluminum Throttle Cable Bracket
Kit for Holley 4150/4160 Style
Carburetors
Red, Black, Chrome, Blue

ALUMINUM CARB SPACERS & ADAPTERS

SP9131

Holley/AFB 4BBL Spacer Kit
3/8" Vac-Tube Included, 1" Open Port

SP9132

Holley/AFB 4BBL Spacer Kit,
2" Open Port

SP9144

Holley/Rochester 2BBL to any Q-Jet
Spread Bore Manifold Adapter Kit,
1-1/8" Open Port



JM3101



Aluminum Throttle Cable Bracket Kit
for Holley 4150/4160 Style Carburetors



SP9131

Holley/AFB 4BBL Spacer Kit
1" Open Port



SP9132

Holley/AFB 4BBL Spacer Kit
2" Open Port



SP9144

Holley/Rochester 2BBL to any Q-Jet
Spread Adapter Kit 1-1/8" Open Port

SP9130

Holley to Q-Jet Adapter Kit, 3/4" Tapered Open Port

SP9140

4BBL Universal Adapter Kit, 1/2" Ported

SP9148

Holley/AFB 4BBL Adapter to Smaller Manifold Kit, 1/2" Tapered Port

PHENOLIC CARB SPACERS

SP9138

Holley/AFB 4BBL Spacer Kit, 1/2" Open Port

SP9136

Holley/AFB 4BBL Spacer Kit, 1" Open Port

SP9137

Holley/AFB 4BBL Spacer Kit, 2" Open Port

SP9134

Holley/AFB 4BBL Spacer Kit, 1" Ported

SP9135

Holley/AFB 4BBL Spacer Kit, 2" Ported



SP9130

Holley to Q-Jet Adapter Kit 3/4" Tapered Open Port



SP9140

4BBL Universal Adapter Kit 1/2" Ported

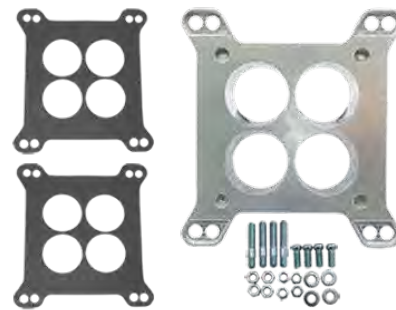

SP9148

Holley/AFB 4BBL Adapter to Smaller Manifold Kit, 1/2" Tapered Port



SP9138

Holley/AFB 4BBL Spacer Kit, 1/2" Open Port



SP9136

Holley/AFB 4BBL Spacer Kit, 1" Open Port



SP9137

Holley/AFB 4BBL Spacer Kit, 2" Open Port



SP9134

Holley/AFB 4BBL Spacer Kit, 1" Ported



SP9135

Holley/AFB 4BBL Spacer Kit, 2" Ported



SP7207

24" Black Plastic Throttle Cable



SP7208

24" Braided Stainless Steel Throttle Cable for Carbureted Applications

THROTTLE, KICK-DOWN & CHOKE CABLES

SP7207

24" Black Plastic Throttle Cable
Universal Applications

SP7208

24" Braided Stainless Steel Throttle Cable for Carbureted Applications
**Also works with Ford EFI, 1986-1993*

SP7209

36" Braided Stainless Steel Throttle Cable for Carbureted Applications
**Also works with Ford EFI, 1986-1993*

SP6049

GM/Chevy TH350 Braided Stainless Steel Kick-Down Cable

SP6050

GM/Chevy 700R4 Braided Stainless Steel Kick-Down Cable

SP6048

6 FT. Braided Stainless Steel Choke Cable
**Recommended Mount Hole 3/8" Diameter*

FUEL LINES

SP9279

Chrome Steel Fuel Line
Fits Holley Carb 3310 8-21/32" Centers

SP9278

Chrome Steel Fuel Line
Fits Holley Quad 9-5/16" Centers



SP7209

36" Braided Stainless Steel Throttle Cable for Carbureted Applications

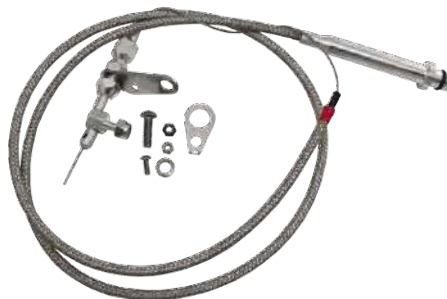

SP6049

GM/Chevy TH350 Braided Stainless Steel Kick-Down Cable

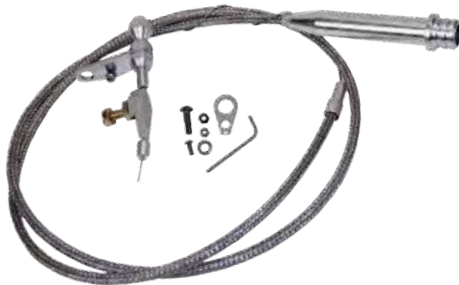

SP6050

GM/Chevy 700R4 Braided Stainless Steel Kick-Down Cable

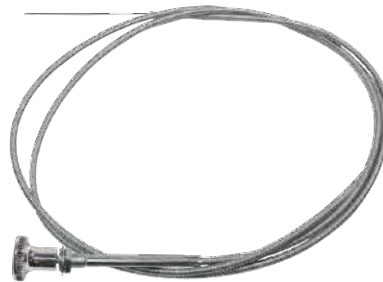

SP6048

6 FT. Braided Stainless Steel Choke Cable



SP9279

Chrome Steel Fuel Line
Fits Holley Carb 3310



SP9278

Chrome Steel Fuel Line
Fits Holley Quad

SP9281

Chrome Steel Fuel Line
Fits Edelbrock/Carter Carbs
3/8" NPT Inlet

SP9282

Chrome Steel Fuel Line
Fits Holley Carbs Barb Hose Fitting
3/8" NPT Inlet



SP9281

Chrome Steel Fuel Line
Fits Edelbrock/Carter Carbs

SP9282

Chrome Steel Fuel Line
Fits Holley Carbs

SP8436

Ford GT40 1/2" Thick Phenolic Manifold Heat Spacer

SP8438

Ford GT40 1" Thick Phenolic Manifold Heat Spacer

SP8437

Ford Stock EFI 5.0L 1/2" Thick Phenolic Manifold Heat Spacer

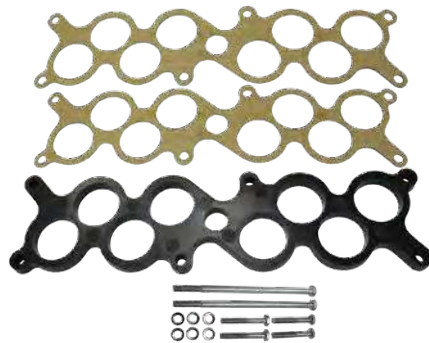

SP8436

Ford GT40 1/2" Thick Phenolic Manifold Heat Spacer

SP8438

Ford GT40 1" Thick Phenolic Manifold Heat Spacer

MANIFOLD HEAT SPACER GASKETS

SP6134

Ford GT40 Manifold Heat Spacer Gasket

SP6133

Ford Stock EFI 5.0L Manifold Heat Spacer Gasket



SP8437

Ford Stock EFI 5.0L 1/2" Thick Phenolic Manifold Heat Spacer

SP6134

Ford GT40 Manifold Heat Spacer Gasket



SP6133

Ford Stock EFI 5.0L Manifold Heat Spacer Gasket

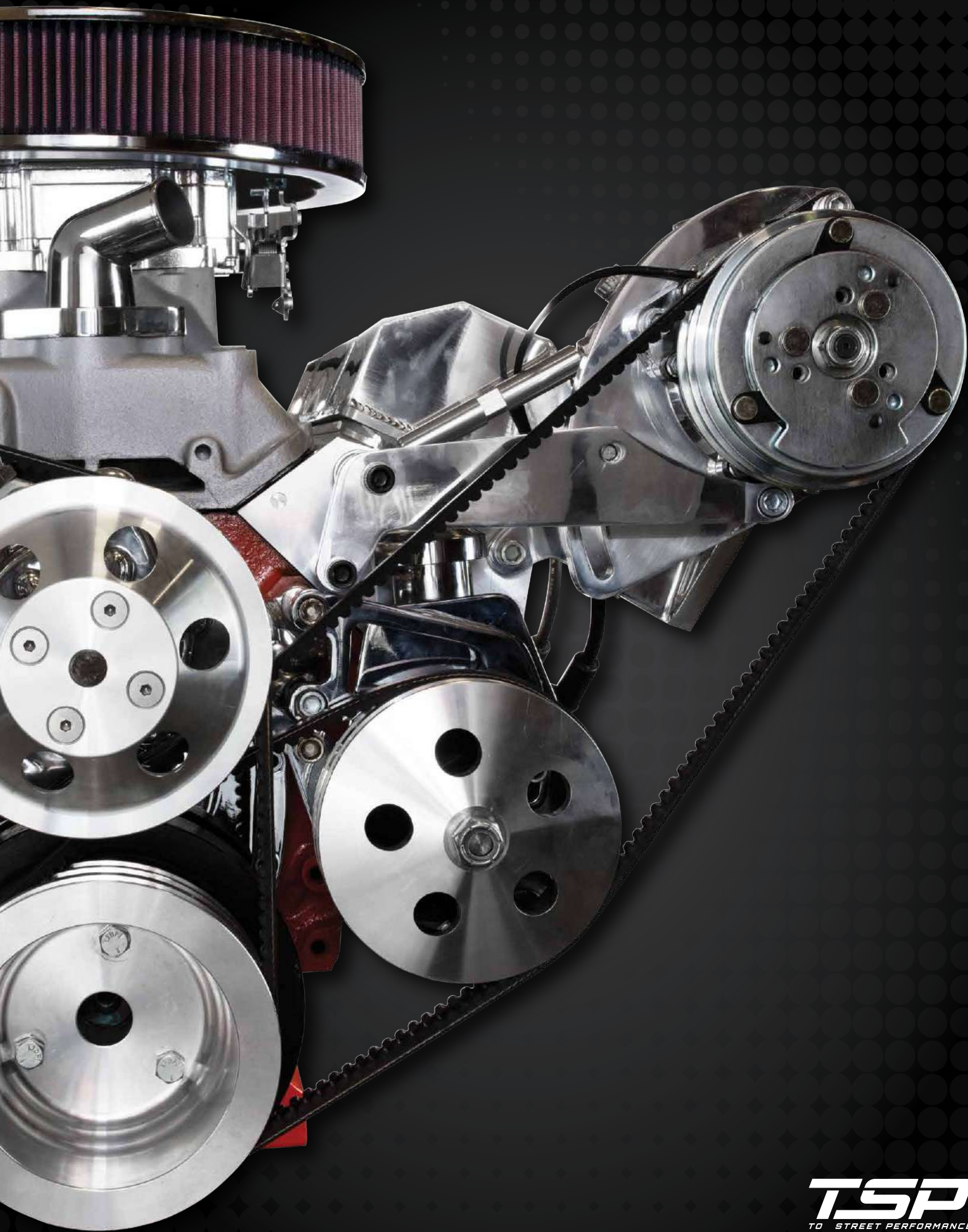

TSP
TO STREET PERFORMANCE

STEERING



Billet aluminum cap



Chrome finish



High quality OEM replacement



JM2000C
GM Saginaw Power Steering
Pump with Billet Aluminum Cap

TSP's Steering Pumps and Boxes are built with high-quality materials to ensure performance and reliability. We have the most popular types to fit many applications, and our chrome pumps will greatly improve the look of any engine.

**JM2003C**

CH

GM Early Saginaw Power Steering Pump, Keyway Style

**JM2010**

BK CH S

GM Type II Power Steering Pump

**JM2011**

BK CH S

GM Type II Power Steering Pump Steel Reservoir

**JM2001**

CH

GM Saginaw Power Steering Pump Steel Reservoir

**JM2002**

CH

Billet Aluminum Cap with Dipstick for Saginaw Power Steering Pump

**JM2004**

CH

GM Early Saginaw Power Steering Pump Steel Reservoir

**JM2020**

BK

Vega Style Steering Box

POWER STEERING PUMPS

JM2000

GM Saginaw Power Steering Pump with Billet Aluminum Cap & Dipstick, Keyway Style, Fits: 1955-1972
Black, Chrome

JM2003C

GM Early Saginaw Power Steering Pump with Billet Aluminum Cap & Dipstick, Keyway Style
Chrome

JM2010

GM Type II Power Steering Pump -10AN Inlet, -6AN Outlet
Black, Chrome, Satin

JM2011

GM Type II Power Steering Pump with Reservoir -6AN Outlet
Black, Chrome, Satin

STEERING COVERS & CAP

JM2001

GM Saginaw Power Steering Pump Steel Reservoir
Chrome

JM2002

Billet Aluminum Cap with Dipstick for Saginaw Power Steering Pump
Chrome

JM2004

GM Early Saginaw Power Steering Pump Steel Reservoir
Chrome

STEERING BOX

JM2020

Vega Style Steering Box
Cast Iron Black

'32 FORD HI-BOY***HC6051**

1932 Ford "Hi-Boy" 2 Row Radiator

- 17.25" x 27.00"
- 1.50" Inlet, 1.75" Outlet
- Billet Aluminum Neck
- 17 fins per inch
- Machine TIG welded
- Downflow design

**Must use Chevy Engine*

'32 FORD LO-BOY***HC6052**

1932 Ford "Lo-Boy" 2 Row Radiator

- 17.25" x 22.50"
- 1.50" Inlet, 1.75" Outlet
- Billet Aluminum Neck
- 17 fins per inch
- Machine TIG welded
- Downflow design

**Must use Chevy Engine*

'32 FORD REAR-END KIT

Fully adjustable 1" diameter by 0.156" wall tubing with 3/4" rod ends and nylon bushings.

CB5101

Ford Triangulated 4-Link Rear-End Suspension Kit (Plain Steel)

- Ford models (1932)

CB5102

Ford Triangulated 4-Link Rear-End Suspension Kit (Stainless Steel)

- Ford models (1932)

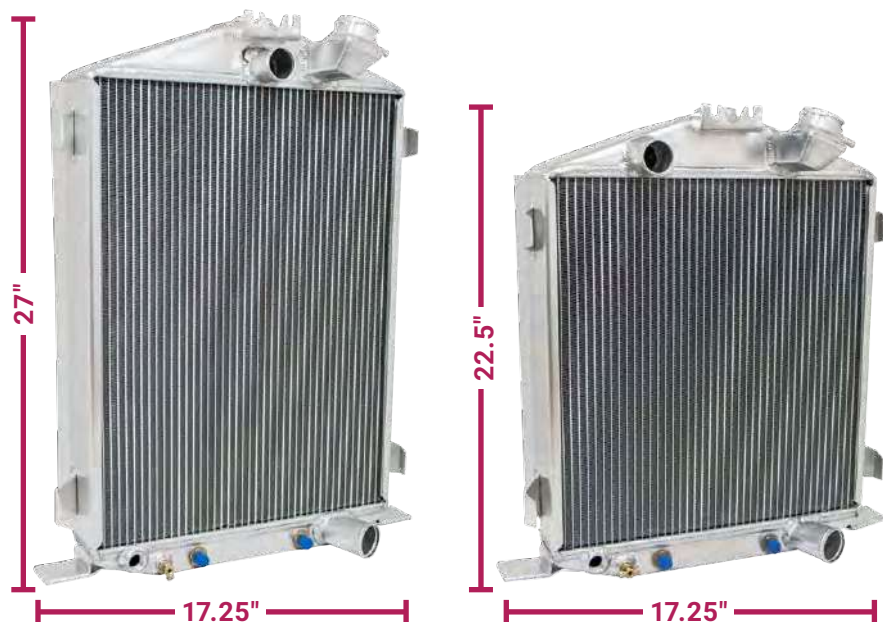
**HC6051**

'32 Ford "Hi-Boy" 2 Row Radiator

HC6052

'32 Ford "Lo-Boy" 2 Row Radiator

**CB5101**

'32 Ford Rear-End Kit Plain Steel

**CB5102**

'32 Ford Rear-End Kit Stainless Steel



AC1001

'32 Ford Steel Grill Shell (Without Hole)



AC1002

'32 Ford Steel Grill Shell (With Hole)

'32 FORD GRILL SHELL

AC1001

1932 Ford Steel Grill Shell without Crank Hole, Smooth on Top Black

- Ford models (1932)
- High quality steel
- Primed and ready for paint
- Exact reproduction of original

AC1002

1932 Ford Steel Grill Shell with Crank Hole, Hole on Top Black

- Ford models (1932)
- High quality steel
- Primed and ready for paint
- Exact reproduction of original

BLACK < SERIES



JM7701-2ABK

Chevy SB/BB V8 Engine Pro Series Ready to Run, Fixed Collar



JM7702ABK

Ford SB 289/302W V8 Engine Pro Series Ready to Run



JM6501ABK

Chevy SB/BB V8 Engine HEI Distributor, OEM Cap



JM6510ABK

Ford 351 Windsor V8 Engine HEI Distributor



ES1001BK

GM 10SI Alternator V-Belt, 110 AMP



ES1004BK

GM Denso Style Mini Alternator V-Belt, 90 AMP



ES1006BK

GM CS130 Alternator Serpentine Belt, 160 AMP



JM7007ABK

Chevy SB/BB 1.9HP Starter, Staggered Mount, Denso Style

BLACK SERIES

JM7701-2ABK (Fixed Collar)

Chevy SB/BB V8 Engine Pro Series Ready to Run Distributor, Fixed Collar

JM7702ABK

Ford SB 289/302 V8 Engine Pro Series Ready to Run Distributor

JM7706ABK

Ford 351 Cleveland/Ford BB 429-460 V8 Engine Pro Series Ready to Run Distributor

JM7710ABK

Ford 351 Windsor V8 Engine Pro Series Ready to Run Distributor

JM6501ABK

Chevy SB/BB V8 Engine, 65K Volt Coil HEI Distributor, OEM Cap

JM6502ABK

Ford SB 289/302 V8 Engine, 65K Volt Coil HEI Distributor

JM6506ABK

Ford 351 Cleveland/Ford BB 429-460 V8 Engine, 65K Volt Coil HEI Distributor

JM6510ABK

Ford 351 Windsor V8 Engine, 65K Volt Coil HEI Distributor

ES1001BK

GM 10SI Alternator, 110 AMP, V-Belt, 1 or OEM Wire Setup, Fits 1968-1982

ES1004BK

GM Denso Style Mini Alternator, Street Rod Race, 90 AMP, V-Belt, 1 Wire Setup

ES1006BK

GM CS-130 Alternator with Side Battery Post, 160 AMP, Serpentine Belt, 1 or OEM Wire Setup, Fits 1968-1995

ES1024BK

GM LS Truck AD244 Alternator, 220 AMP, Serpentine Belt, 4 Pin Connector

ES1025BK

GM LS Car CS130D Alternator, 180 AMP, Serpentine Belt, 4 Pin Connector

JM7007ABK

Chevy SB/BB 1.9HP Starter, Staggered Mount, Denso Style, 168 Tooth Flywheel

JM7008ABK

Oldsmobile/Pontiac 1.9HP Starter, Denso Style
- Will not fit 301

JM7009ABK

GM LSX 1.9HP Starter, Denso Style

JM7013ABK

Mopar SB/BB/Hemi 1966-1987 1.9HP Starter with Nose, Denso Style
Red, Black, All Black

HC5001BK

Sanden 508 R134A Style A/C Compressor V-Belt

HC5002BK

Sanden 508 R134A Style A/C Compressor Serpentine Belt

HC5005BK

Sanden SD-7 Style A/C Compressor Serpentine Belt, 6 Groove

HC8011BK

Chevy SB Aluminum Mechanical Water Pump, Short Style

HC8012BK

Chevy SB Aluminum Mechanical Water Pump, Long Style

HC8021BK

Chevy BB Aluminum Mechanical Water Pump, Short Style

HC8022BK

Chevy BB Aluminum Mechanical Water Pump, Long Style

HC8049BK

Aluminum Mechanical Water Pump, Passenger Side Inlet

JM9101BK

Chevy SB Long Water Pump, Passenger Side, Aluminum Alternator Bracket Kit

JM9105-1BK (New Design)

Chevy SB Long Water Pump, Aluminum Power Steering Pump Bracket Kit

JM9106BK

Chevy SB Long Water Pump, Driver Side, Aluminum A/C Compressor Bracket Kit

81045BK

GM LS1/LS2/LS6 Valley Cover

JM2010BK

GM Type II Power Steering Pump -8AN Inlet, -6AN Outlet



JM7013ABK

Mopar SB/BB/Hemi 1.9HP Starter, Denso Style



HC5001BK

Sanden 508 Style V-Belt A/C Compressor



HC5005BK

Sanden SD-7 Style Serpentine Belt A/C Compressor



HC8012BK

Chevy SB Aluminum Mechanical Water Pump, Long Style



JM9101BK

Chevy SB LWP, Aluminum Alternator Bracket Kit



JM9105-1BK

Chevy SB LWP, Aluminum Power Steering Pump Bracket Kit



81045BK

GM LS1/LS6 Valley Cover



JM2010BK

GM Type II Power Steering Pump



JM1020BK

Dual Fuel Pump & Fuel Filter Aluminum Mounting Bracket, Bosch 044 Style



**Fittings Included*

JM1040BK

Universal Electric EFI Inline Fuel Pump 350 LPH, Bosch 044 Style



JM1003BK

Chevy SB 262-400 Mechanical Fuel Pump, 6 PSI



JM1037BK

Chevy SB V8 Engine Super Flow Racing Mechanical Fuel Pump



SP6490BK

Oval Half Finned Aluminum Air Cleaner, Paper Kit, 12" x 8-3/8"



SP8458BK

Billet Aluminum Wire Loom Set, Finned

JM1020BK

EFI Inline Bosch 044 Style Dual Fuel Pump and Fuel Filter Aluminum Mounting Bracket

JM1040BK

Universal Electric EFI Inline Fuel Pump 350 LPH Bosch 044 Style, -10AN Inlet, -6AN Outlet Up to 800HP

JM1003BK

Chevy SB 262-400 Mechanical Fuel Pump, V8 Engine, 6 PSI 1/4" NPT Inlet/Outlet

JM1004BK

Chevy BB 396-454 Mechanical Fuel Pump, V8 Engine, 6 PSI 1/4" NPT Inlet/Outlet

JM1007BK

Ford SB 221-351 Windsor Mechanical Fuel Pump, V8 Engine, 6 PSI 1/4" NPT Inlet/Outlet

JM1037BK

Chevy SB Super Flow Racing Mechanical Fuel Pump, V8 Engine, 12-16 PSI 1/2" NPT Inlet/Outlet

SP6490BK

Oval Half Finned Aluminum Air Cleaner with Paper Kit, 12" x 8-3/8" Size, 3-3/8" Height

SP6491BK

Oval Half Finned Aluminum Air Cleaner with Paper Kit, 15" x 8-3/8" Size, 3-3/8" Height

SP6498BK

Oval Full Finned Aluminum Air Cleaner with Paper Kit, 12" x 8-3/8" Size, 3-3/8" Height

SP8442BK

Chevy SB 265-350, 1955-1979 4-Qt Rear Sump Finned Aluminum Oil Pan, Driver Side Dipstick

SP8450BK

Dual Finned Aluminum Hood Scoop, Fits Single or Dual 4-Barrel Carb Application with 5/18" Neck 19-1/2" Length, 10" Width, 5-1/2" Height

SP8458BK

Billet Aluminum Wire Loom Set, 9.5mm Finned

SP8486BK

Oval Finned Aluminum Push-in Breather

SP8487BK

Oval Finned Aluminum Push-in Breather with PCV Valve



SP8450BK

Dual Finned Aluminum Hood Scoop



SP8487BK

Oval Finned Aluminum Push-in Breather with PCV Valve

SP8525BK

1958-1986 Chevy SB 283-400 Short Finned Aluminum Valve Cover with Hole, 3-1/2" Height



SP8525BK

Chevy SB 283-400 Short Finned Aluminum Valve Cover, 3-1/2" Height

SP8526BK

1958-1986 Chevy SB 283-400 Tall Finned Aluminum Valve Cover with Hole, 4" Height



SP8527BK

Chevy SB 5.0L-5.7L Short Finned Aluminum Valve Cover, 3-1/4" Height

SP8527BK

1987-1999 Chevy SB 5.0L-5.7L Short Finned Aluminum Valve Cover with Hole, 3-1/4" Height

SP8528BK

1987-1999 Chevy SB 5.0L-5.7L Tall Finned Aluminum Valve Cover with Hole, 4" Height

SP8530BK

1965-1995 Chevy BB 396-502 Tall Finned Aluminum Valve Cover with Hole, 4-1/4" Height



SP8530BK

Chevy BB 396-502 Tall Finned Aluminum Valve Cover, 4-1/4" Height

SP8491BK

GM TH350 Finned Aluminum Transmission Oil Pan



**Gasket & Drain Plug Included*

SP8491BK

GM TH350 Finned Aluminum Transmission Oil Pan

SP8593BK

GM TH400 Finned Aluminum Transmission Oil Pan

SP8594BK

GM 700R4 Finned Aluminum Transmission Oil Pan



**Gasket & Drain Plug Included*

SP8593BK

GM TH400 Finned Aluminum Transmission Oil Pan



**Gasket & Drain Plug Included*

SP8594BK

GM 700R4 Finned Aluminum Transmission Oil Pan

SP8854BK

Chevy SB LWP Water Pump Pulley, Single Groove



SP8854BK

Chevy SB LWP Water Pump Pulley, Single Groove

SP8856BK

Chevy SB LWP Water Pump Pulley, Double Groove



SP8856BK

Chevy SB LWP Water Pump Pulley, Double Groove



SP8859BK

Chevy SB LWP Crankshaft Pulley,
Triple Groove



SP8848BK

Chevy Power Steering Pulley,
Single Groove



SP8850BK

Chevy SB SWP Water Pump Pulley,
Single Groove



SP8852BK

Chevy SB SWP Water Pump Pulley,
Double Groove



SP8851BK

Chevy SB SWP Crankshaft Pulley,
Single Groove



SP8853BK

Chevy SB SWP Crankshaft Pulley,
Double Groove



SP8858BK

Chevy SB SWP Crankshaft Pulley,
Triple Groove



T1001

7 Piece AN Combination Wrench Set
-3AN to -20AN

SP8859BK

Chevy SB LWP Crankshaft Pulley,
Triple Groove

SP8848BK

Chevy SB/BB Power Steering Pulley,
Single Groove

SP8850BK

Chevy SB SWP Water Pump Pulley,
Single Groove

SP8852BK

Chevy SB SWP Water Pump Pulley,
Double Groove

SP8851BK

Chevy SB SWP Crankshaft Pulley,
Single Groove

SP8853BK

Chevy SB SWP Crankshaft Pulley,
Double Groove

SP8858BK

Chevy SB SWP Crankshaft Pulley,
Triple Groove

T1001

7 Piece AN Combination Wrench Set
-3AN to -20AN

PRO BILLET DISTRIBUTOR INSTALLATION

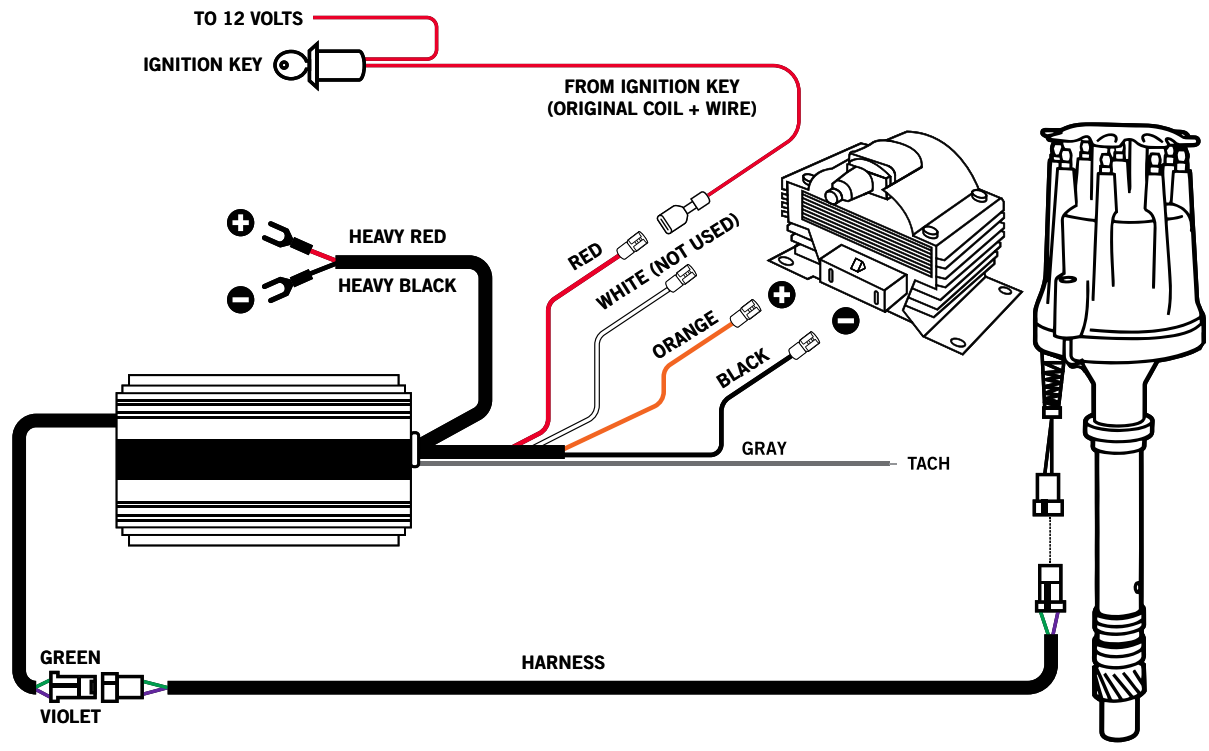

WARNING: This distributor is not compatible with stock points distributor coil, must use high output coil. Must bypass ballast resistor if applicable.

PRO SERIES READY TO RUN INSTALLATION

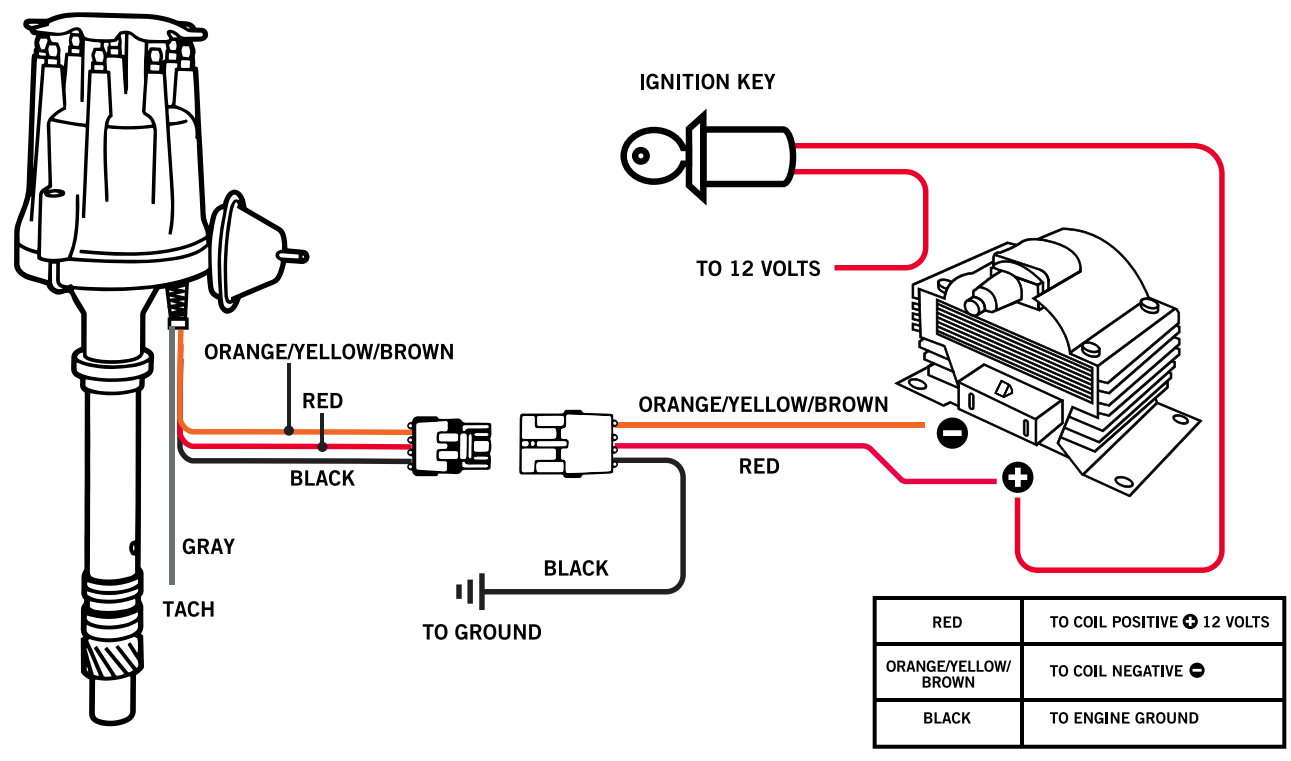

READY TO RUN INSTALLATION

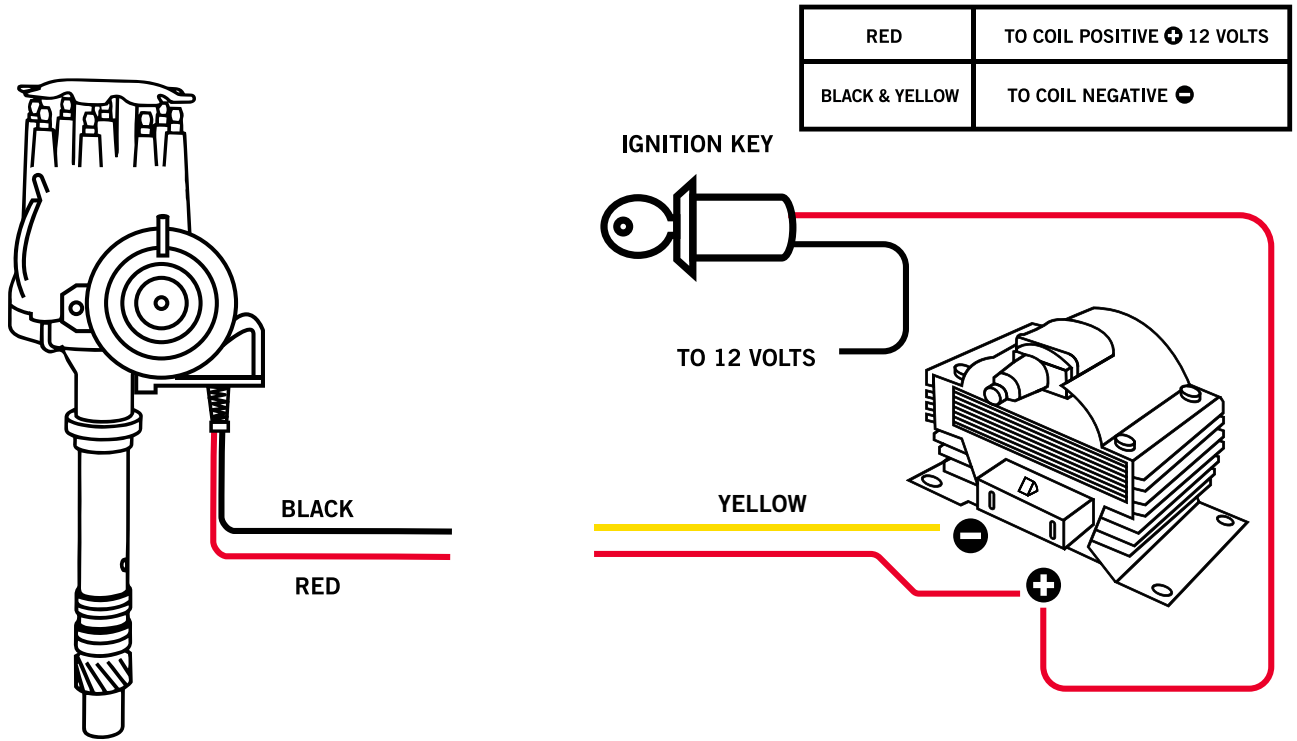

WARNING: This distributor is not compatible with stock points distributor coil, must use high output coil. Must bypass ballast resistor if applicable.

DISTRIBUTOR CAP DIMENSIONS

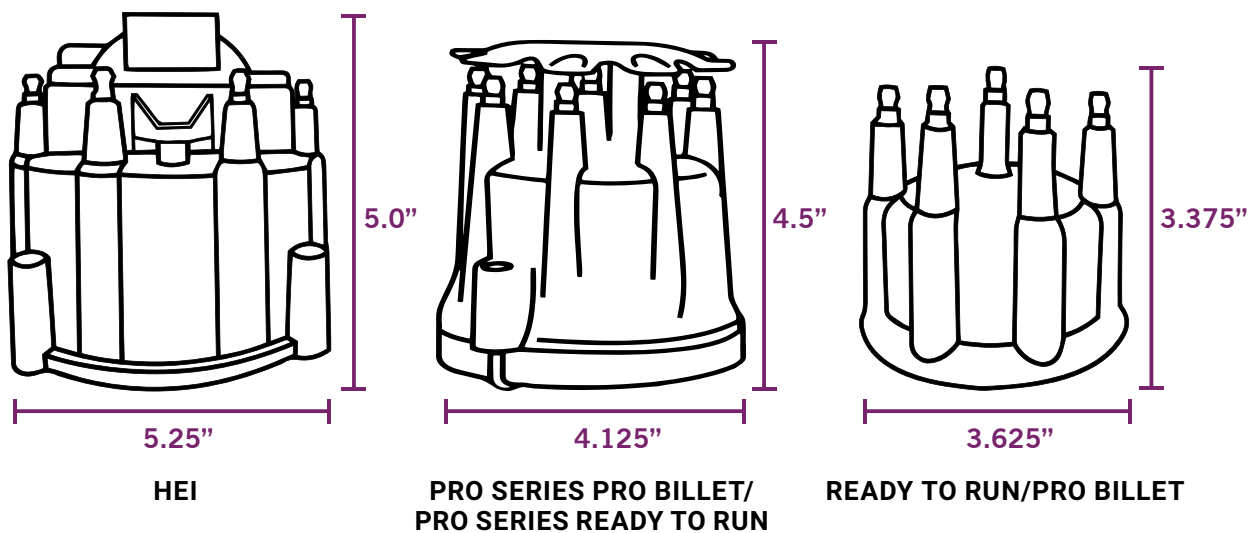

STANDARD UNIVERSAL FANS

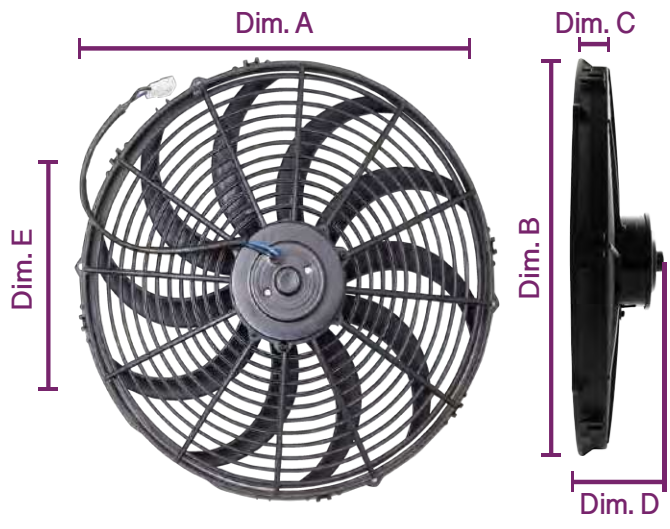

SIZE	PRODUCT NO.	DIM. A	DIM. B	DIM. C	DIM. D	DIM. E
8"	HC6101	8 1/8"	8"	1 1/4"	2 1/4"	4 3/8"
10"	HC6102	11 1/2"	10 3/4"	1 1/2"	2 3/8"	8 7/8"
12"	HC6103	13"	12 1/8"	1 1/2"	2 3/8"	6 3/16"
14"	HC6104	14 7/8"	14"	1 1/2"	3 1/8"	7 1/8"
16"	HC6105	16 1/2"	15 5/8"	1 1/8"	3 5/8"	14"

PRO SERIES S-BLADE FANS

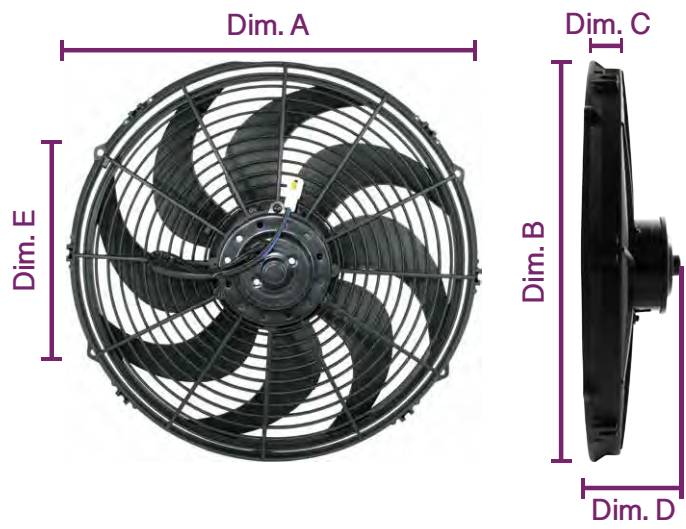

SIZE	PRODUCT NO.	CFM	AMP DRAW	DIM. A	DIM. B	DIM. C	DIM. D	DIM. E
10"	HC7102	650	7.5	10 5/8"	11 1/4"	1 1/4"	2 1/2"	5 5/8"
12"	HC7103	870	10.0	11 5/8"	11 3/4"	1 3/8"	2 1/2"	6 7/16"
14"	HC7104	1,200	12.0	14 7/16"	15 1/4"	1 3/8"	3 1/2"	7 1/8"
16"	HC7105	1,600	14.0	15 5/8"	16"	1 3/8"	3 3/4"	8 1/8"

PRO FLOW FANS

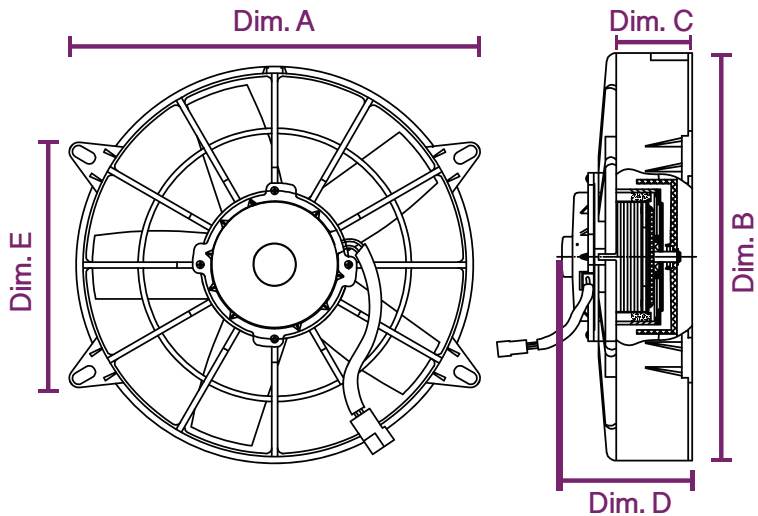

SIZE	PRODUCT NO.	TRUE CFM	AMP DRAW	DIM. A	DIM. B	DIM. C	DIM. D	DIM. E
11"	HC7211	1,400	13.9	11 1/2"	12"	2 1/4"	3 3/4"	6 1/2"
12"	HC7212	1,600	10.0	13 1/4"	13"	2 3/8"	4"	9 3/8"

PRO FLOW FANS

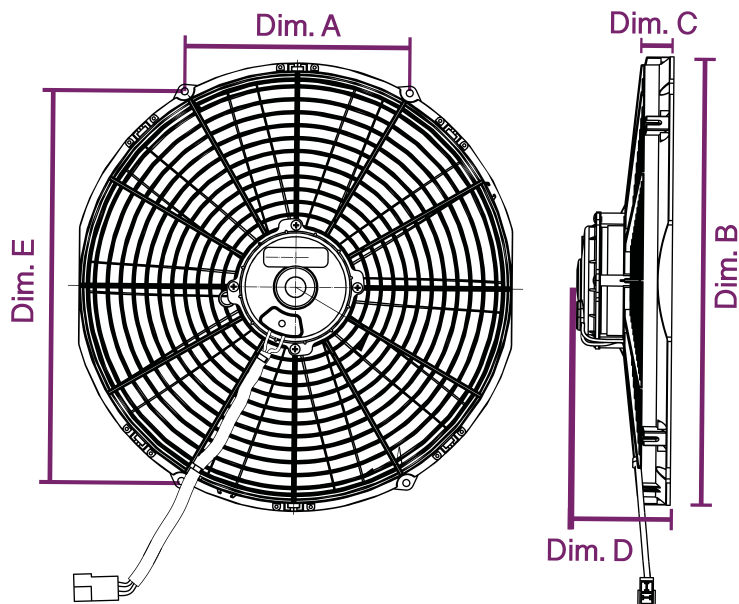

SIZE	PRODUCT NO.	TRUE CFM	AMP DRAW	DIM. A	DIM. B	DIM. C	DIM. D	DIM. E
14"	HC7214	1,800	18	7 1/2"	15"	1 1/2"	3 1/2"	13"
16"	HC7216	2,000	20	8"	16"	1 1/2"	3 1/2"	14"

ALTERNATOR DIMENSIONS

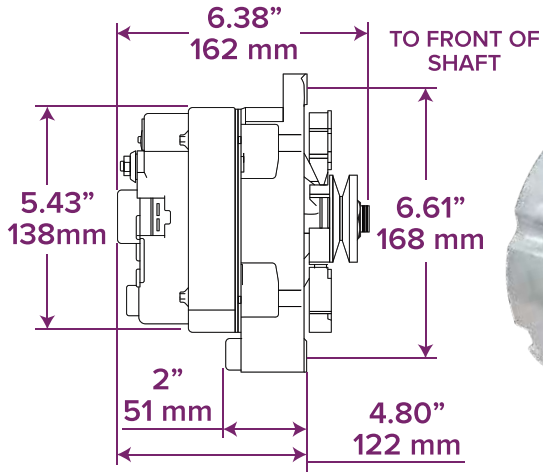

ES1001C
GM 10SI Alternator, 110 AMP, V-Belt,
1 or OEM Wire Setup, Fits 1968-1982

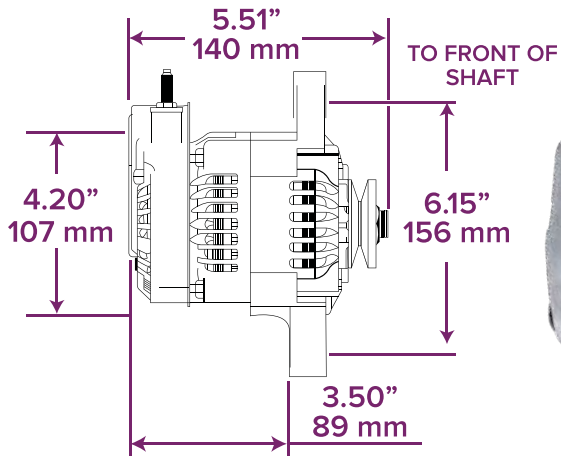

ES1004C
GM Denso Style Mini Alternator,
Street Rod Race, 90 AMP, V-Belt,
1 Wire Setup

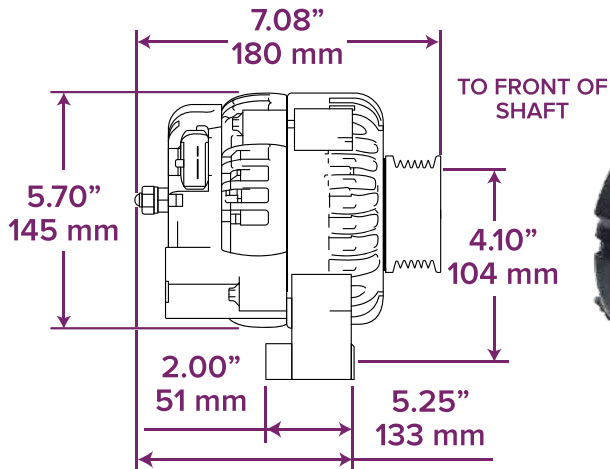

ES1024C
GM LS Truck AD244 Alternator,
220 AMP, Serpentine Belt,
4 Pin Connector

1-WIRE ALTERNATOR INSTALLATION INSTRUCTIONS

CAREFULLY READ THESE INSTRUCTIONS BEFORE ATTEMPTING INSTALLATION!

INSTALLATION: To install an alternator, disconnect the positive battery cable, unbolt and remove the original alternator, install the alternator and re-tension the drive belts. Then run a single wire of the proper gauge from the alternator 'Battery' terminal to the positive terminal on the battery or to the starter solenoid main lug (connects to the positive battery post). Adjust belt tension so that the belt has approximately 1/2" of deflection and tighten belt tension bolt. Tension belt with hand pressure on alternator (do not use pry bars or anything similar on alternator). Reconnect the positive battery cable, start the engine and using a multi-meter, verify that the alternator is charging at least 13.8 volts at 1000 RPM's.

GROUNDING REQUIREMENTS: In order for an alternator to charge properly, the alternator must be grounded to the engine block. If an alternator has paint or clear-coat on the mounting surfaces, it may not be grounded and will not charge.

CORRECT WIRE SIZE IS CRITICAL: It is very important to use the correct wire size to connect the alternator to the battery. A wire size too small can allow the wire to overheat, melt the insulation and cause a fire or worse. Depending upon the maximum output of the alternator, use the following chart as a minimum wire size guide. Wire size is based on 4' battery cables. Trunk mounted batteries require heavier gauge battery cables - contact Tech Service for recommendation. One wire alternators eliminate the unsightly factory wiring harness and simplifies installation by using only one wire for charging.

AMPERAGE	UP TO 4 FT.	4-7 FT.	7-10 FT.	10-13 FT.	13-16 FT.
35-50	12	12	10	10	10
50-65	10	8	8	6	6
65-85	10	8	8	6	6
85-105	8	8	6	4	4
105-125	6	6	4	4	2
125-150	6	6	4	2	2
150-175	4	4	4	2	2
175-200	4	4	2	2	0

STARTER DIMENSIONS

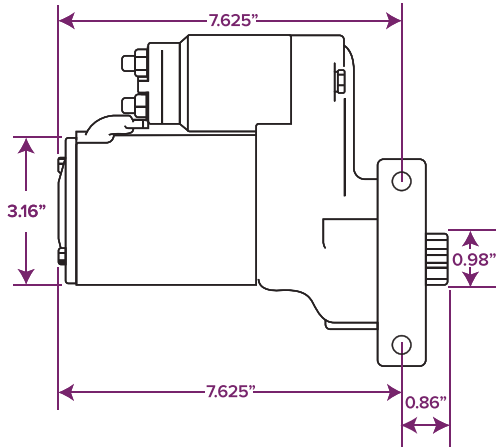

JM7001
Chevy SB/BB 3HP High Torque Starter, 153 or 168 Tooth Flywheel, Tilton Style

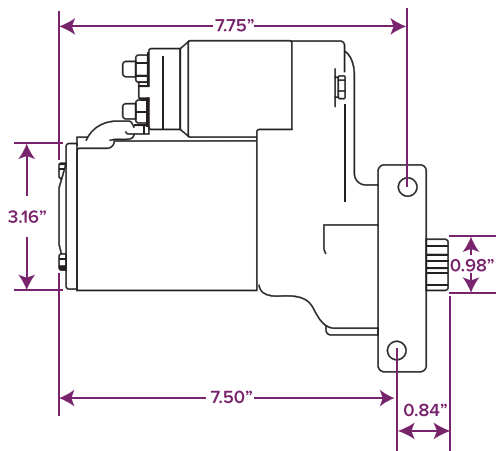

JM7002
GM LSX 3HP High Torque Starter, Tilton Style

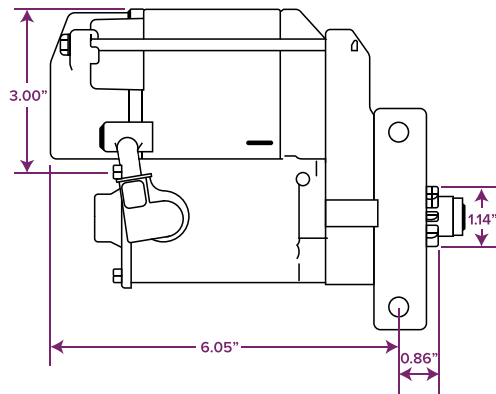

JM7007
Chevy SB/BB 1.9HP Starter, Staggered Mount, Denso Style, 168 Tooth Flywheel

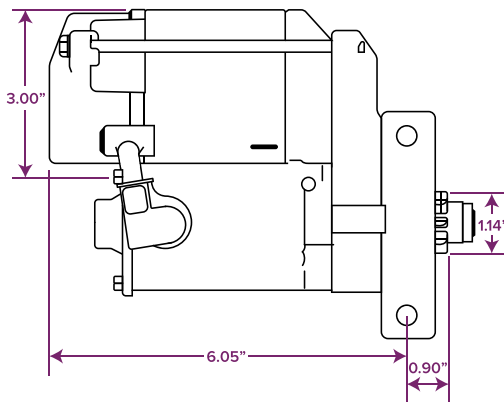

JM7009
GM LSX 1.9HP Starter, Denso Style

A/C COMPRESSOR DIMENSIONS

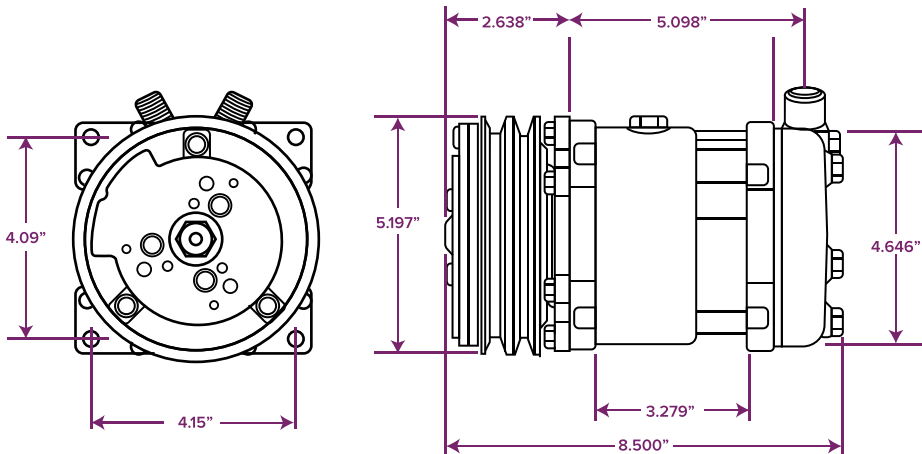

HC5001
Sanden 508 R134A Style
A/C Compressor V-Belt

HC5003
Sanden 508 R134A Style
A/C Compressor V-Belt

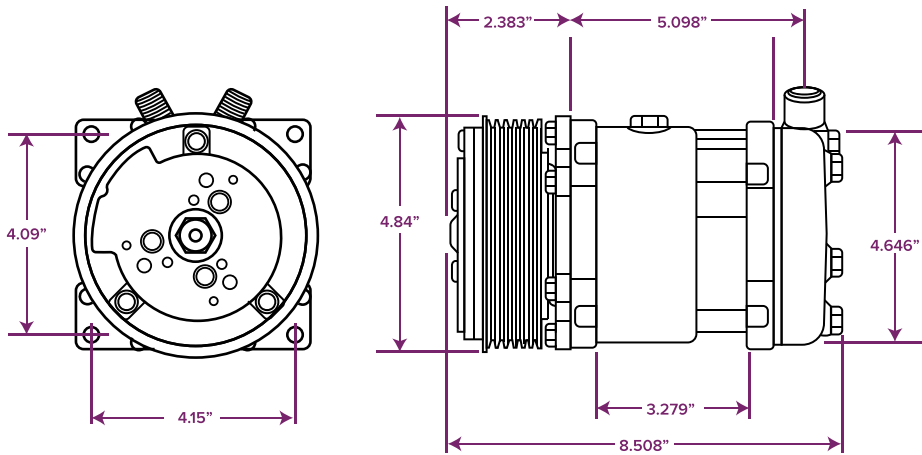

HC5002
Sanden 508 R134A Style
A/C Compressor Serpentine Belt

HC5004
Sanden 508 R134A Style
A/C Compressor Serpentine Belt

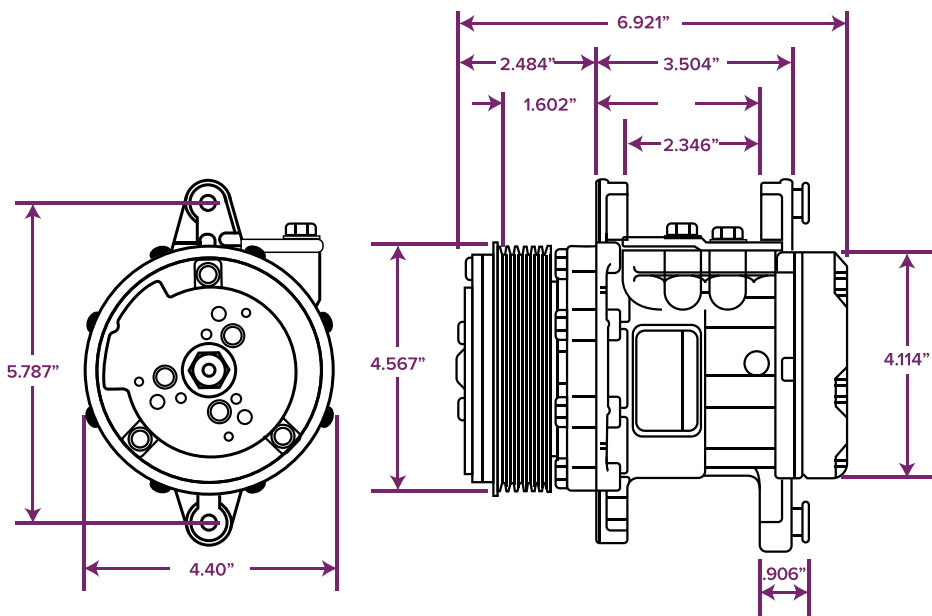

HC5005
Sanden SD-7 Style A/C Compressor
Serpentine Belt, 6 Groove

TSP VELOCITY® INTAKE DIMENSIONS

81001: LS1/LS2/LS6 INTAKE MANIFOLD

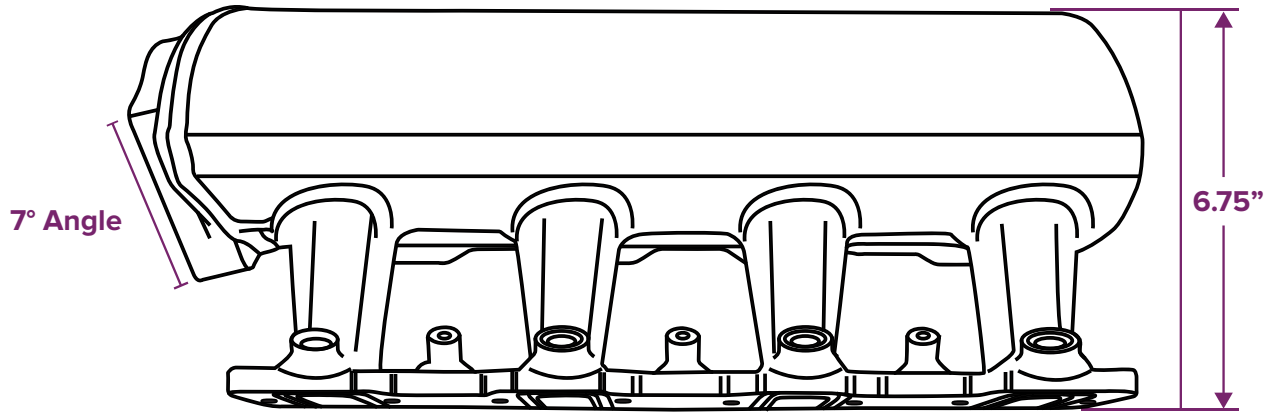

81002: LS1/LS2/LS6 INTAKE MANIFOLD

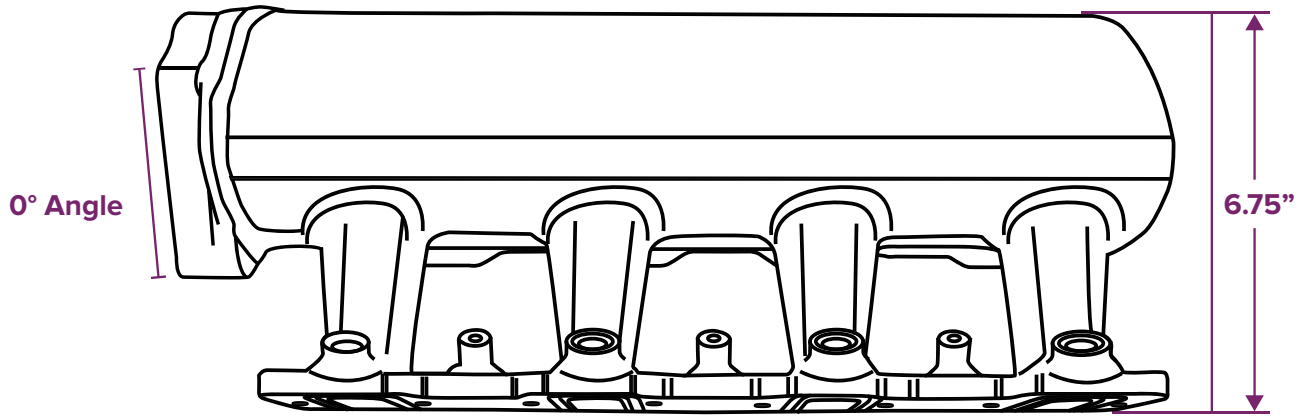

81003: LS3/L92 INTAKE MANIFOLD

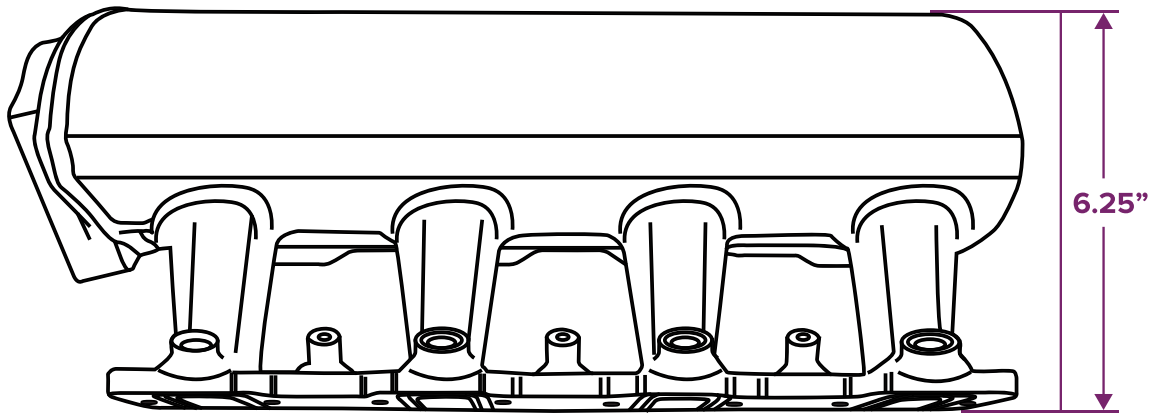

TSP VELOCITY® LS INTAKE DIMENSIONS

81002T: LS1/LS2/LS6 HI-RAM INTAKE MANIFOLD
81003T: LS3/L92 HI-RAM INTAKE MANIFOLD

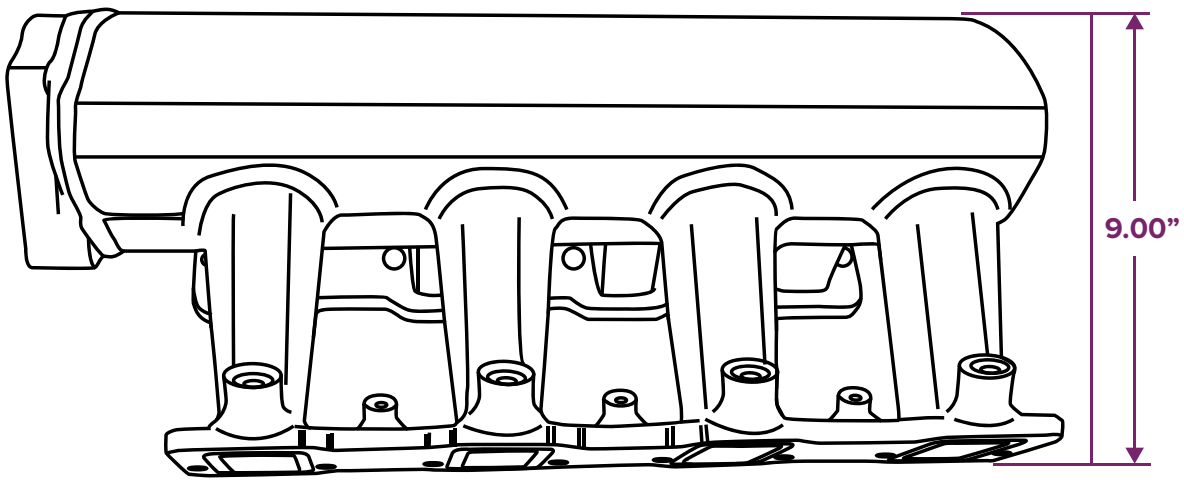

81007: LS7 INTAKE MANIFOLD

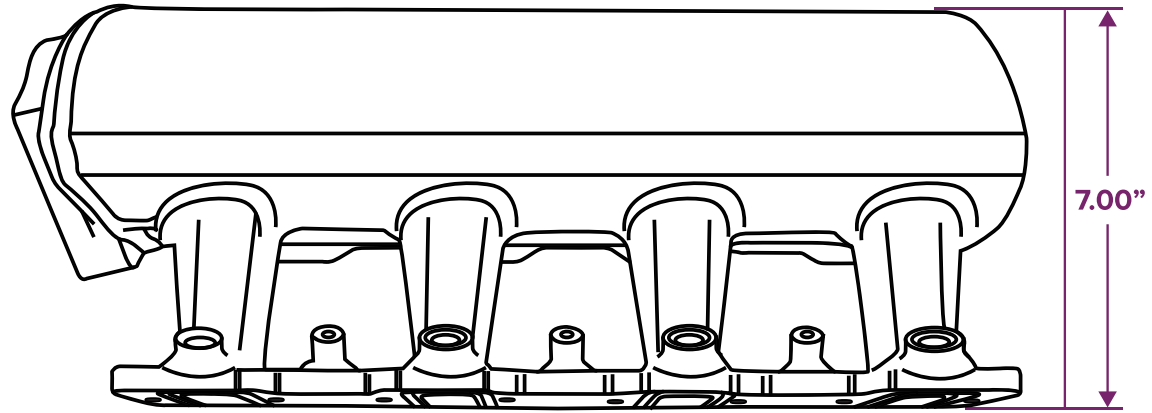

TSP VELOCITY® FORD COYOTE 5.0L INTAKE DIMENSION

84050: FORD COYOTE 5.0L INTAKE MANIFOLD

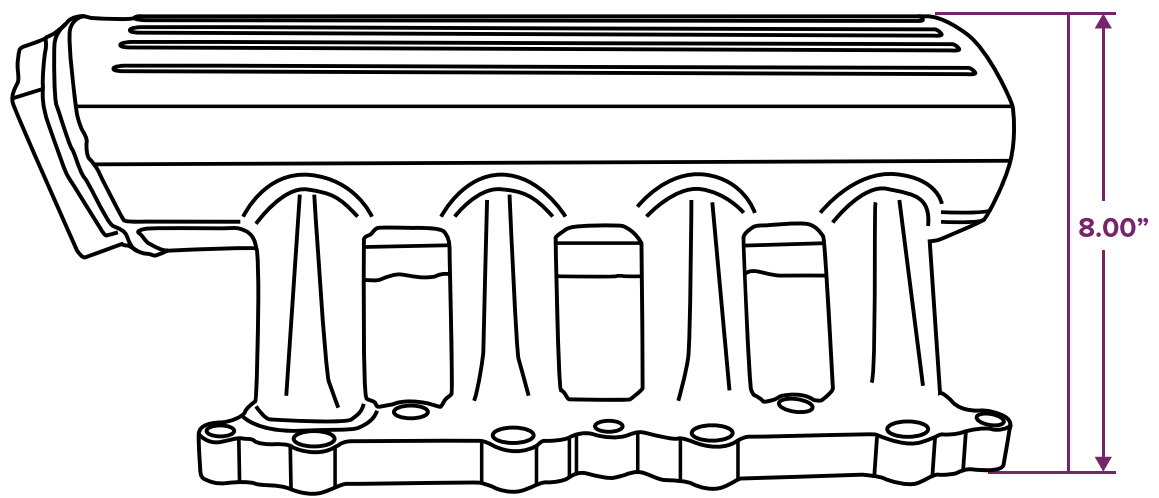

LS OIL PAN DIMENSIONS

81004-R: LS OIL PAN REAR SUMP

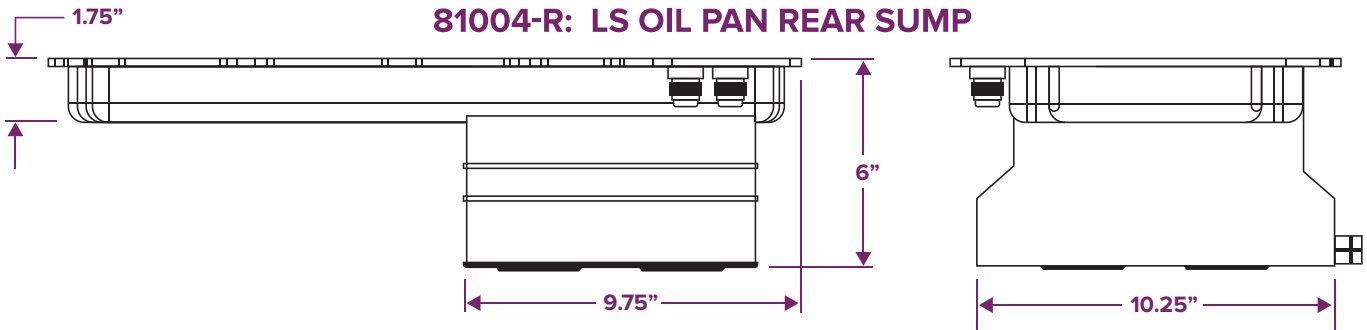

81004-F: LS OIL PAN FRONT SUMP

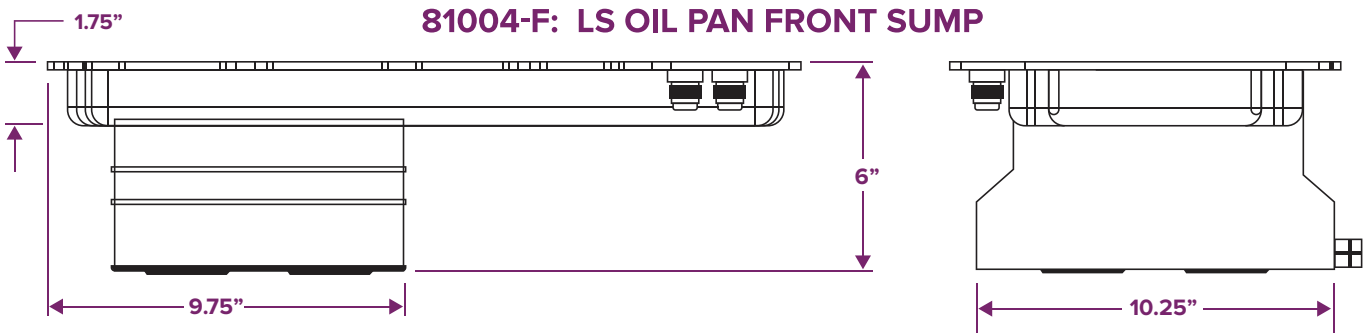

81073: LS LOW PROFILE RETRO FIT OIL PAN

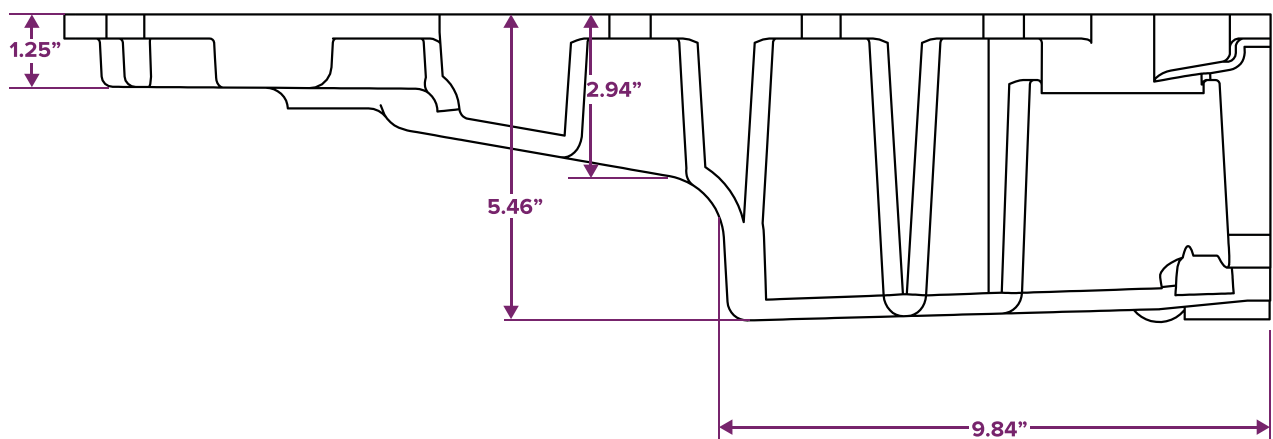

81074: LS RETRO FIT OIL PAN

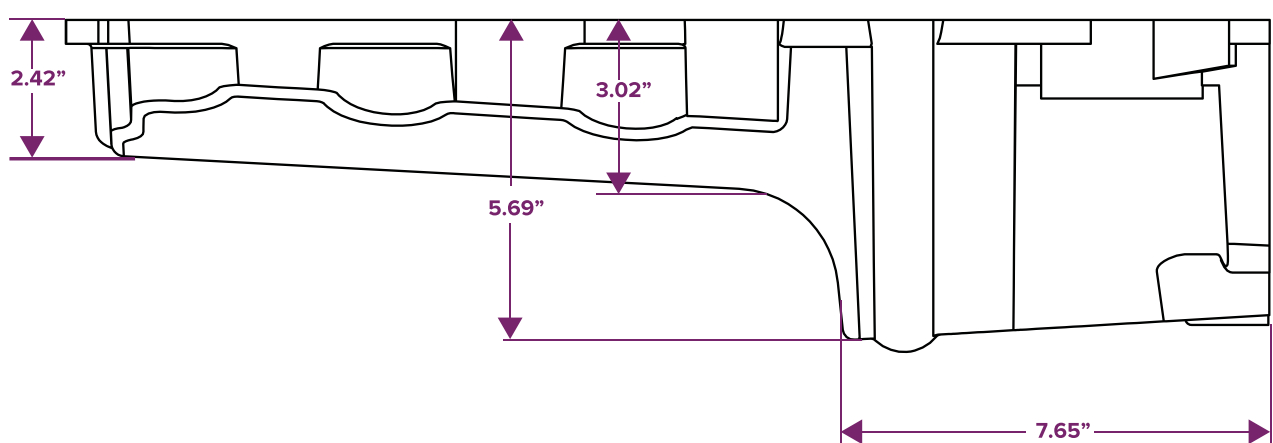

TERMS AND POLICIES

NEW ACCOUNTS

New wholesale customers may be required to submit a copy of their business license within the United States. All California based companies must submit a current copy of their California Resale Certificate for proof of tax exempt status. If not submitted and/or updated, all orders for said customers will be charged at the current sales tax rate for Los Angeles County, CA (9% as of 2016).

CREDIT

Top Street Performance may choose to authorize a customer to apply for credit terms. Application authorization and approval are determined at the sole discretion of Top Street Performance. If approved, customer must abide by terms set forth in credit agreement. All invoices must be paid by the posted due date. Past due accounts will be put on credit hold and will be subject to late fees. No orders will be released until past due amount has been paid in full. Top Street Performance reserves the right to revoke credit terms or close any account not kept in good standing. There are no early payment discounts.

ORDERS

Non-online orders may be placed by phone, email, or fax. On all orders will be charged a shipping and handling fee, unless other arrangements have been made or certain order qualifications have been met. Call for additional information. Products ordered that are not in stock will be placed on back order. Once back ordered product becomes available, Top Street Performance will confirm with customer as to whether or not said product is still desired. If so, customer will then be charged and the item shipped. Back orders may be canceled at any time.

SHIPPING METHODS

All orders are shipped "F.O.B. TSP" or "Prepaid" depending on whether or not the order meets certain qualifications. Call for additional information. Top Street Performance reserves the right to choose the method of shipment at their discretion, unless other arrangements are agreed upon. Customer will be responsible for any miscellaneous charges such as re-consignment or re-delivery in which the customer is at fault, delivery appointment, residential delivery, lift gate delivery, etc. Customer may request to use their own freight company. Top Street Performance will gladly ship orders on customer's account. Upon delivery, it is the customer's responsibility to verify that the correct number of cartons have been received, noting any discrepancies on delivery receipt or bill of lading before signing for goods. Top Street Performance will not honor any claims for carton shortages otherwise.

SHORTAGES

Shortages must be reported to Top Street Performance within 48 hours of delivery. If it is determined that a carton has been lost in transit, Top Street Performance will make an attempt to locate said carton with the aid of the freight carrier before re-shipping any product. If Top Street Performance is at fault, the missing products will be shipped free of charge. Customer may not make any deduction on an invoice when remitting payment. If there are any discrepancies that require correction, customer must inform Top Street Performance so a credit memo can be issued.

RETURNS

Top Street Performance will accept returns of *new, unused merchandise, in their original condition and original packaging*, within 90 days of purchase date. Top Street Performance must be given advance notification of any returns, new or defective, being shipped back. Customer must call for RMA (Return Merchandise Authorization) number prior to shipping. All returns must be clearly labeled with RMA number and must contain a copy of the original invoice. After 30 days, non-defective returns may be subject to a 15% restocking fee. Within 2-3 business days of receipt of non-defective merchandise by Top Street Performance, store credit will be issued for the sale price of the product less any fees. Any product ordered but refused upon delivery by customer will be subject to restocking fee and refusal fee, in addition to any return shipping charges.

NOTICE

Top Street Performance reserves the right to alter prices and/or services without prior notification.



Rely only on high-grade performance ignition systems offered on our virtual shelves.