



LIPPERT
COMPONENTS®
GOLD CIRCLE DEALER

2020 MERCHANDISE CATALOG

PROFIT PROGRAMS
IN-STORE MARKETING
RETAIL PACKAGING
DISPLAYS & PLANOGRAMS

TABLE OF CONTENTS

INTRODUCTION...2-5

- Table of Contents...2
- We Make It Easy...3
- Gold Circle Dealer®...4
- Pillars to Success...5

DEALER PROFIT PROGRAMS...6-43

INTERIOR...6-13

- Thomas Payne® Collection Furniture...6-9
- Teddy Bear Bunk Covers...10
- Floë Drain Down System™...11
- Flow Max™ Water Pumps...12
- Flow Max™ Galley Faucets...13

SOLERA® AWNINGS...14-21

- Solera Universal Introduction...14-15
- Solera Universal Hardware...16
- Solera Universal Shades and Rooms...17
- Solera Universal Replacement Fabrics...18
- Solera Universal Slide Toppers...19
- Solera Universal Awmbrella™...20
- Solera Universal Club Program...21

STEPS & JACKS...22-27

- Solid Step®...22-23
- Jack-IT® Bike Solutions...24-25
- Manual Steps...26
- Tongue Jacks...27

LEVELING & STABILIZATION...28-33

- Ground Control® Leveling...28
- JT's Strong Arm...29
- Trailair Pin Boxes...30
- Sway Command®...31
- Stabilization...32
- Power Stabilizer...33

REPAIR & REPLACE...34-38

- Brake Assembly...34
- Slide-Out Repair Parts...35
- Alpha Systems Sealants...36-37
- Axle and Suspension Repair Parts...38

FREE GOLD CIRCLE PROGRAMS...39-43

- Step and Chassis Care...39
- RV Air Freshener...40
- 360 Siphon®...41
- Screen Shot®...42
- Thin Shade...43

IN-STORE MARKETING...44-49

- Planogram and Product Displays...44-45
- Spider Banners and POP Displays...46-47
- Retail Packaging...48-49

WE MAKE IT EASY. YOU MAKE THE SALE.

Lippert Components, Inc. (LCI®) develops custom product solutions in a broad range of categories that enhance the mobile lifestyle. We're proud to be a leading supplier of premium components to the recreational vehicle, residential housing, trailer, bus, marine and heavy truck industries. With state-of-the-art facilities, machinery and operational processes, we're committed to continued growth and improvement in all of the industries we serve.

We give you the personal attention and marketing support you deserve with must-have products, value-added profit programs, and comprehensive marketing and sales support. We give you all the tools you need to make products fly off the shelves!





LIPPERT
COMPONENTS®
GOLD CIRCLE DEALER®



Premier Customer
Support



Specialized
Marketing Solutions



Priority Profit
Program Support



Warranty Claims
Priority



Targeted Consumer
Advertising



Social Media
Consultation

We want to build strong relationships with our committed partners like you, and help you succeed with value-added profit center programs, must-have products and comprehensive marketing and sales support.

Gold Circle Dealer[®]: Pillars to Success

Buy 12, Get 5 FREE (Over \$2,000 USD in retail value)

Achieve LCI[®] Gold Circle Dealer[®] status today! Qualification is easy and the benefits are strong.

Here is what it takes:

Purchase a minimum of 12 Dealer Profit Programs from our 2020 Profit Program lineup. We have changed up existing programs and added great new programs to make it easier than ever for your dealership to achieve Gold Circle status.

But that's not all. Here is some great news for you!

Qualify in all 5 pillars, LCI will give your dealership 5 selected Dealer Profit Programs for FREE! These 5 programs represent over \$2,000 USD in retail value, making Gold Circle status more profitable for your dealership. Talk to your LCI Sales Representative today and get started on the Pillars to Success.

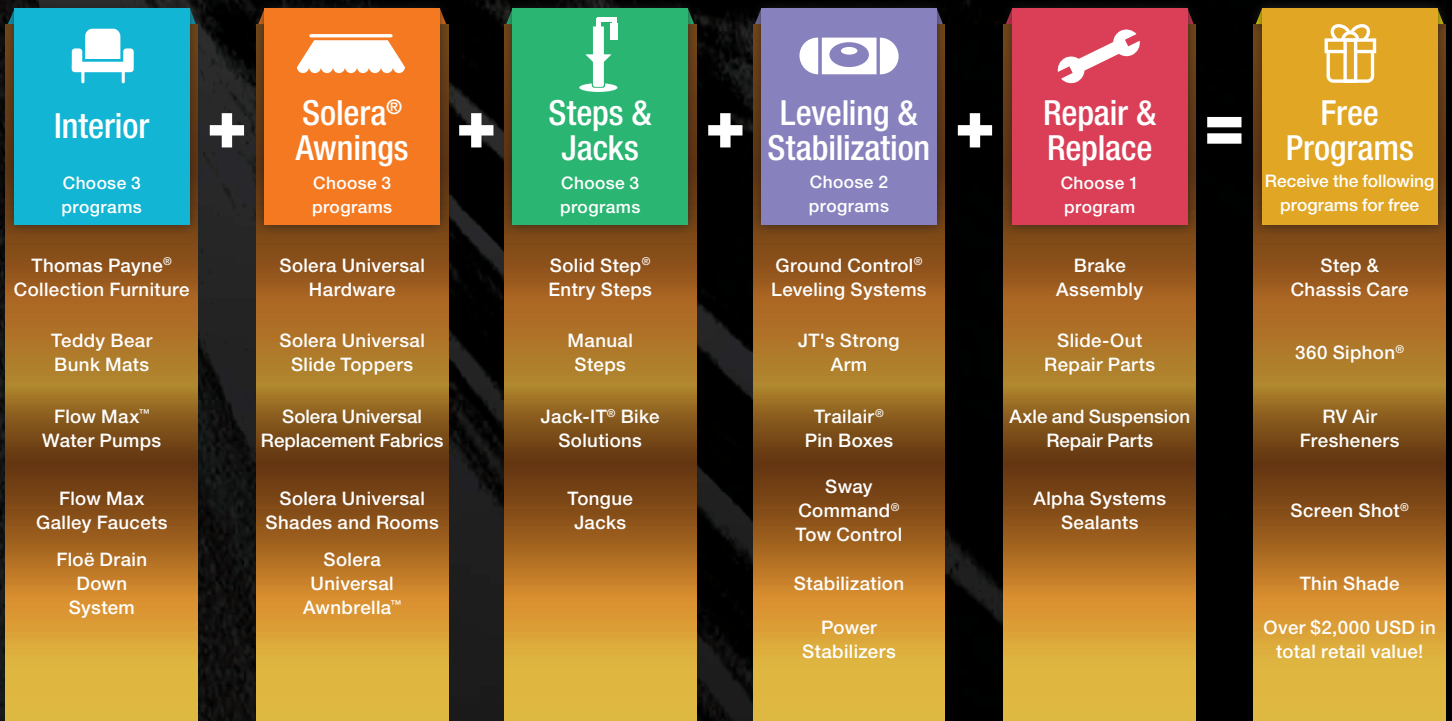

JOIN THE GOLD CIRCLE DEALER PROGRAM TODAY



RENEW. REFRESH. RESTORE.

Quality workmanship and unsurpassed comfort are the foundation upon which every piece of Thomas Payne® Collection furniture is built. Equally impressive is the high level of functionality this furniture offers. With innovative styles and multiple upholstery options, Thomas Payne has the RV seating and sleeping options to suit your every need.

GIVE YOUR CUSTOMERS THE COMFORT THEY WANT WITH THE THOMAS PAYNE COLLECTION PROFIT PROGRAM.

- Beautiful and easy to clean PolyHyde® Euro Leather Vinyl
- Multiple colors, sizes and styles to choose from
- Modular theater seating provides multiple reclining configurations
- Versatile Jackknife and Tri-Fold Sofas convert to comfortable beds

SEISMIC SERIES



Shown in Majestic Chocolate

THEATER SEATING

Not only does Thomas Payne® Collection Theater Seating feature plush, inviting and easy-to-clean PolyHyde® upholstery, it also has an optional center console that provides a storage compartment and two recessed cup holders. This versatile and attractive modular theater seating features smoothly operating recliners and requires minimum wall clearance.

Theater Seating Components:

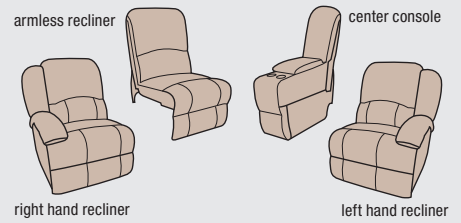

HERITAGE SERIES



Shown in Cobble Creek

Available Colors & Fabric:

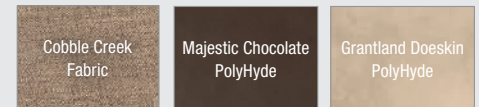

TRI-FOLD SOFA

At home or in your RV, attractive, comfortable and quality furniture always brings people together and adds life to any room. Luxurious Thomas Payne® Collection Tri-Fold Sofa seating features durable construction and quality materials.

Available Colors & Fabric:

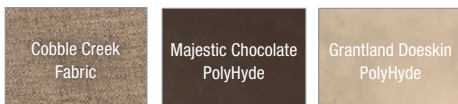

Shown in Grantland Doeskin

THOMAS PAYNE® COLLECTION FURNITURE DEALER PROFIT PROGRAM

INTERIOR

RECLINER CHAIRS

Enjoy total relaxation whether sitting upright or fully reclined in the classic Thomas Payne® Collection Push Back Recliner or Swivel Glider Recliner. Choose from three elegant colors to complement your RV décor.

Available Colors & Fabric:



Swivel Glider Recliner
Shown in Majestic Chocolate



Push Back Recliner
Shown in Cobble Creek



Shown in Oxford Walnut

JACKKNIFE SOFAS

With one easy motion, the steel-framed Jackknife RV Sofa converts to a bed of high-density foam. The steel spring seating supports provide a sturdy base for relaxing or sleeping.

Available Colors & Fabric:

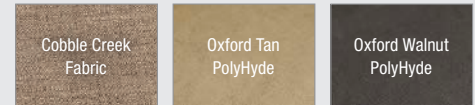

EURO RECLINER CHAIRS

Relax after a long day of adventure in the comfortable and compact Thomas Payne® Collection Euro Recliner Chair. This versatile seat is covered in attractive and durable PolyHyde® leather vinyl upholstery and features a comfortable footrest.

Available Colors & Fabric:

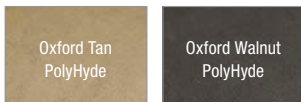

Shown in Oxford Walnut



Shown in Oxford Tan

THOMAS PAYNE® COLLECTION FURNITURE DEALER PROFIT PROGRAM

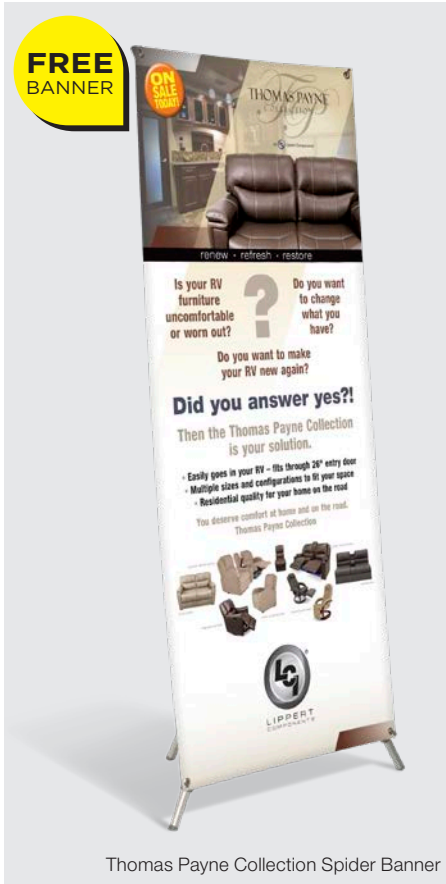

Thomas Payne Collection Spider Banner



FREE DISPLAY OPPORTUNITY!

Purchase the Gold or Silver Level Thomas Payne® Collection Furniture Dealer Profit Program and receive the marketing materials as outlined in the Gold and Silver programs.

Limited time offer - while supplies last. Limit one display per dealership. Minimum order to qualify. Free qualifying display is to be kept clean, visible to consumers in retail store, and showcase only LCI product.

THOMAS PAYNE® SILVER DEALER PROFIT PROGRAM

LCI Part #	Description	Color	Qty.	Dealer Price	Program
380398	Push Back Recliner	Grantland Doeskin	1		
759229	Seismic Theater Seating Right Hand Recliner	Majestic Chocolate	1		
759232	Seismic Theater Seating Left Hand Recliner	Majestic Chocolate	1		
759233	Seismic Theater Seating Center Console	Majestic Chocolate	1		
711084	Thomas Payne Spider Banner		1	FREE	FREE
405203	Thomas Payne Fabric Sample Board		1	FREE	FREE

Total:

THOMAS PAYNE® GOLD DEALER PROFIT PROGRAM

LCI Part #	Description	Color	Qty.	Dealer Price	Program
379930	Destination Tri-Fold Sofa - 68"	Grantland Doeskin	1		
759229	Seismic Theater Seating Right Hand Recliner	Majestic Chocolate	1		
759232	Seismic Theater Seating Left Hand Recliner	Majestic Chocolate	1		
759233	Seismic Theater Seating Center Console	Majestic Chocolate	1		
759237	Seismic Theater Seating Armless Recliner	Majestic Chocolate	1		
759298	Swivel Glider Recliner	Cobble Creek	1		
377054	Push Back Recliner	Majestic Chocolate	1		
643643	Euro Recliner Chair	Oxford Tan	1		
768200	Gold Level Showroom Display Carpet - 10' x 10'		1	FREE	FREE
711084	Thomas Payne Spider Banner		1	FREE	FREE
405203	Thomas Payne Fabric Sample Board		1	FREE	FREE

Total:

TEDDY BEAR BUNK COVERS DEALER PROFIT PROGRAM

INTERIOR



Teddy Bear Bunk Covers

SOFT AND INVITING

The Teddy Bear Bunk Mattress Cover provides a soft and inviting sleep surface while protecting RV mattresses from dirt and debris. The soft and comforting sleep surface is perfect for children.

Available in multiple sizes and two color options, the Teddy Bear Bunk Mattress Cover easily zips onto your existing RV bunk mattress, providing a plush, inviting sleep surface perfect for lounging and sleeping.



Teddy Bear Bunk Cover Display

FREE WALLPAPER DISPLAY OPPORTUNITY!

Purchase 12 Teddy Bear Bunk Covers and receive the 4' planogram wallpaper for FREE!

Limited time offer - while supplies last. Limit one display per dealership. Minimum order to qualify. Free qualifying display is to be kept clean, visible to consumers in retail store, and showcase only LCI product.

TEDDY BEAR BUNK COVER DEALER PROFIT PROGRAM

LCI Part #	Description	Size	Thickness	Qty.	Dealer Price	Program
679285	Teddy Bear Bunk Matt Cover, Chocolate	32" x 74"	3"	3		
679294	Teddy Bear Bunk Matt Cover, Tan	32" x 74"	3"	3		
679299	Teddy Bear Bunk Matt Cover, Chocolate	32" x 74"	4"	3		
679300	Teddy Bear Bunk Matt Cover, Tan	32" x 74"	4"	3		
711092	Teddy Bear Profit Program Wallpaper - 4'			1	FREE	FREE
					Total:	



Floë Drain Down System



Floë Packaging

PROTECT YOUR RV OR BOAT FROM WATER DAMAGE

Using our integrated and automated 12 volt Floë 636 Induratec Water Drainage System, you can ensure that, with the flick of a switch, your property is drained, without ever having to pay someone to do it for you. Using Floë to perform regular drain downs through the summer season will keep your water system in showroom condition.

Floë is fitted once, and when you want to drain down, you simply switch Floë on and open and close each tap or outlet until all are drained of water. It's very simple, if the water isn't there, it can't freeze. Also, should you ever change your property, we've made it so that Floë can be removed without any trace, so you can take it with you. An RV, boat, or any mobile vehicle with a freshwater system and a 12V DC battery power supply, can be drained in as little as 2 minutes. This offers you the peace of mind and convenience of draining down whenever and as often as you like.

FEATURES

- Remove the worry of when to drain for winter protection
- Drain down whenever and as often as you like
- Use your RV or boat through the winter months, simply taking 2 minutes to drain when finished
- Floë cleans your water system, making way for beautifully fresh drinking water
- Floë is patented, WRAS and NCC verified and approved

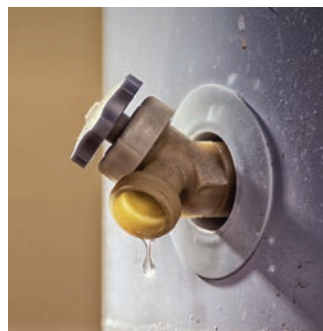

STEP 1

Manually drain water heater and close dump valve and outlets after to seal water system.

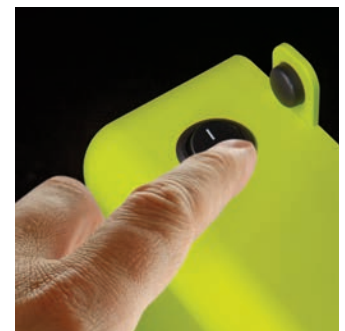

STEP 2

Switch Floë on to compress air into water system.

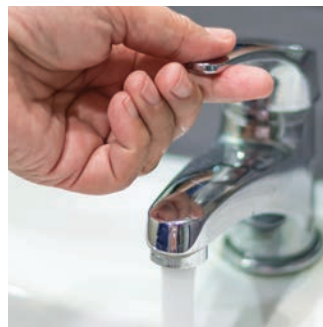

STEP 3

Open and drain each outlet one by one.



STEP 4

Switch Floë off and leave all water outlets open.

FLOË DRAIN DOWN SYSTEM DEALER PROFIT PROGRAM

LCI Part #	Description	Qty.	Dealer Price	Program
809127	Floë 12V Integrated Drain Down System	3		
809128	Floë 115V Integrated Drain Down System	1		
			Total:	

FLOW MAX™ WATER PUMP DEALER PROFIT PROGRAM

INTERIOR



FRESH WATER WHEN YOU NEED IT

Fresh water when you want it and when you need it. Lippert Components' Flow Max water pump delivers a steady flow of water to your RV. Flow Max offers superior performance all at a price below similar products on the market today. Available in both 12V and 115V.

FEATURES

- Self-priming
- Quiet operation
- 2-year limited warranty
- 12V VDC, 9.5 max amps
- Available in 12V and 115V
- Certified to NSF/ANSI 372 by CSA
- Heavy-duty, corrosion resistant motor
- Pump can run dry without incurring damage
- Average leading pressure of 50 PSI with an average GPM of 3.0

Average Gallons Per Minute

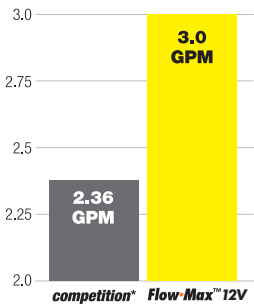

Average Leading Pressure

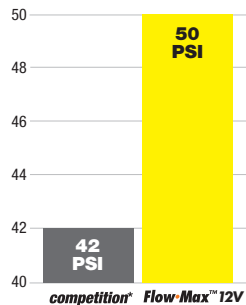

Freeze/Thaw 2-Hour Cycle

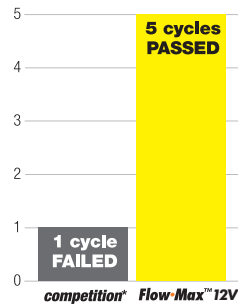

* Compared to SHURflo® Revolution™ 4008 Fresh Water Pump. Independently tested by Progressive Engineering, Inc, Goshen, Indiana USA.

FREE WALLPAPER



FREE WALLPAPER DISPLAY OPPORTUNITY!

Purchase a qualifying combination of Flow Max Pumps and receive the 2' planogram wallpaper for FREE!

Limited time offer - while supplies last. Limit one display per dealership. Minimum order to qualify. Free qualifying display is to be kept clean, visible to consumers in retail store, and showcase only LCI product.

FLOW MAX WATER PUMP DEALER PROFIT PROGRAM

LCI Part #	Description	Qty.	Dealer Price	Program
689052	Water Pump 12V 3.0 w/ Strainer and Connectors	12		
689054	Water Pump 115V 3.0 w/ Strainer and Connectors			
689059	Replacement Screen, Filter and Connectors - Universal	2		
768201	Flow Max Water Pump Profit Program Wallpaper - 2'	1	FREE	FREE
			Total:	

FLOW MAX™ GALLEY FAUCET DEALER PROFIT PROGRAM

**FREE
DISPLAY**



Flow Max Faucet Display

DESIGNED WITH MODERN IN MIND.

Add a splash of modern to your kitchen or bath with a Stainless Steel Faucet by Lippert Components. Available in a variety of spout constructions like coiled spring and high-arched, we're challenging how the world feels about faucets. Constructed with quality stainless steel, these sleek faucets are designed for maximum lifespan and durability.

FREE FLOW MAX FAUCET DISPLAY OPPORTUNITY!

Purchase a qualifying combination of Flow Max Galley Faucets and receive the display for FREE!

Limited time offer - while supplies last. Limit one display per dealership. Minimum order to qualify. Free qualifying display is to be kept clean, visible to consumers in retail store, and showcase only LCI product.



Spring Spout Faucet
Coiled spring faucet helps you easily reach hard-to-reach spots

719323



719326



719335



719325



719333



719324

FLOW MAX GALLEY FAUCET DEALER PROFIT PROGRAM

LCI Part #	Description	Qty.	Dealer Price	Program
719324	Stainless Steel Curved Gooseneck Faucet	1		
719325	Stainless Steel Square Gooseneck Faucet	1		
719326	Stainless Steel Pull Down Sprayer Faucet	1		
719333	Stainless Steel Bullet Pulldown Faucet	1		
719335	Stainless Steel Alphorn Pull Down Faucet	1		
719323	Stainless Steel Spring Spout Faucet	1		
768205	Flow Max Galley Faucet Profit Program Display	1	FREE	FREE

Total:



SOLERA® UNIVERSAL

SOLERA AWNINGS



YOUR UNIVERSAL CHOICE FOR ALL THINGS SUN AND SHADE

We've revamped our entire awning collection to make your life simpler. The Solera® Universal line of awnings and accessories makes it simple and easy to replace your awning. Featuring universal application, Solera Universal products work with competitor awning brands as well as many of Solera's most popular awnings and accessories. With a wide variety of innovative Solera awning models and accessories to choose from, Solera Universal saves time, money and stress.



POWER UP

Power Up your mobile lifestyle with the Solera Smart Arm® 12V Power or 18V Battery Operated awnings. Save yourself the stress and added time of manually setting up your awning!



UPGRADE

Upgrade your current manual or power awning with Solera Universal Hardware! Our hybrid and power awnings set up automatically for camping as they extend.



FIX IT

Tired of your old manual or power awning? With our newly designed Solera Universal hardware, replacing your broken or worn out awning has never been easier, no matter what awning brand you have.

SOLERA® UNIVERSAL DEALER PROFIT PROGRAMS



SOLERA AWNINGS

The Solera® Universal brand has numerous successful dealer profit programs under its belt. The Universal Hardware program supplies you with all the latest hardware to go Universal. Solera Slide Topper's are a big up-sell to your customers, giving them protection from the elements. The Universal Fabric Replacement program has all your awning replacement fabric needs covered, from slide toppers to awnings. Keep your customers camping for longer with the Universal Awnbrella™ program. The Universal Shades and Rooms program lets RVers expand their outdoor living space, create shade and keep the bugs out.

Solera has you covered.

Solera Universal components fit any of these brands:

Dometic* (A&E)

Universal Hardware fits the following Dometic®
8' extension awnings models: 8500, 9000, 9100,
Sunchaser and Weather Pro



Universal Hardware fits the following Solera
8' extension awnings models: 18V Power,
Smart Arm® 12V, Hybrid and Classic Manual.

Carefree™**

Universal Hardware fits the following Carefree™
8' extension awnings models: Spirit, Fiesta,
Simplicity Traveler and Eclipse

*Dometic® is a registered mark and logo owned by Dometic Sweden and A&E is a mark used by Dometic Group.
**Carefree™ and the Carefree logo are a mark and logo used by Carefree of Colorado, member of The Scott Fetzer Co.

SOLERA® UNIVERSAL HARDWARE DEALER PROFIT PROGRAM

SOLERA AWNINGS



SMART ARM® 12V AWNING

The Solera Smart Arm® 12V Power Awning incorporates several intelligent features sure to enhance everyone's camping experience. Best of all, these new features are all accessible from a weatherproof controller built right into the awning arm itself, making for easy and convenient access without having to go inside the RV to operate the switches.



18V POWER AWNING

Upgrading to a power awning has never been easier! An industry first, the Solera 18V Power Pack features a unique, rechargeable battery that fits right inside your Solera Power Awning arm and comes with everything you need to connect to the motor wire.



Smart Arm Proximity/Security Sensor

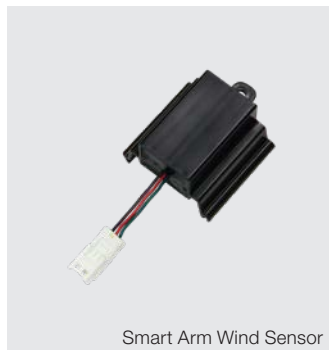

Smart Arm Wind Sensor



Solera Universal Spider Banner

FREE BANNER DISPLAY OPPORTUNITY!

Purchase 3 sets of Solera Universal Hardware plus the Smart Arm® Accessories and get the Spider Banner display FREE! As long as quantity is met, you will qualify for the program.

Limited time offer - while supplies last. Limit one display per dealership. Minimum order to qualify. Free qualifying display is to be kept clean, visible to consumers in retail store, and showcase only LCI product.

SOLERA UNIVERSAL HARDWARE DEALER PROFIT PROGRAM

LCI Part #	Description	Arm Color	Arm Size	Qty.	Dealer Price	Program
434730	Solera Universal 18V Tall Arm	White	69"			
434729	Solera Universal 18V Tall Arm	Black	69"	1		
759404	Solera Universal 12V Smart Arm	White	63"			
759516	Solera Universal 12V Smart Arm	Black	63"	1		
759405	Solera Universal 12V Smart Arm	White	69"			
759517	Solera Universal 12V Smart Arm	Black	69"	1		
715123	Smart Arm Wind Sensor Kit			1		
715124	Smart Arm Infrared Security Sensor Kit			1		
711095	Solera Universal Hardware Spider Banner			1	FREE	FREE

Total:

SOLERA® UNIVERSAL SHADES AND ROOMS DEALER PROFIT PROGRAM



FRONT AND SIDE SHADES

Perfect for all awnings, the one-piece, black Solera Front Shade is easy to slide into your awning roller tube whenever you need a little extra shade, privacy or wind block. Solera Front Shade panels are available in 8', 10', 13', 15', 17' & 19' widths, each with a 6' screen height. The Front Shade kit includes storage bag, spikes and tie downs.



SOLERA SUPER SHADE®

Many of the larger RVs today have patio awnings that are too high to reach when they are fully extended, and that's why we created the Solera Super Shade®! The two-piece, black Solera Super Shade® features a standard 6' shade height that easily zips into a Solera Super Shade® extension and can be permanently installed into your awning's roller tube.



SOLERA FAMILY ROOM®

Turn the space under your awning into an enclosed outdoor patio with the Solera Family Room® kit. Add up to 160 square feet of enclosed space so you can enjoy meals minus pesky insects. Or roll down the all-weather panels and use as a cozy sleeping area for kids. 10-21' rooms available.



SCREEN ROOM

Keep the bugs out and enjoy the breeze with the Solera Screen Room. Its neutral tan material helps to block out extra heat, making the Solera Screen Room perfect for outdoor dining, board games and social gatherings on hot summer days. 10-21' rooms available.

FREE WALLPAPER

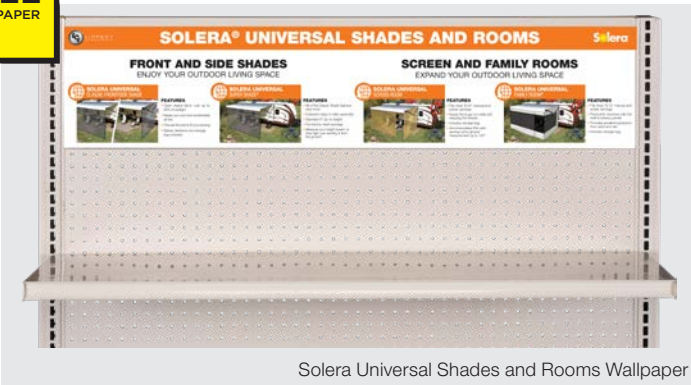

Solera Universal Shades and Rooms Wallpaper

FREE WALLPAPER DISPLAY OPPORTUNITY!

Purchase a qualifying order of Solera Shades and Rooms and receive the 4' Planogram Wallpaper for FREE! As long as quantity of 5 is met, you will qualify for the program.

Limited time offer - while supplies last. Limit one display per dealership. Minimum order to qualify. Free qualifying display is to be kept clean, visible to consumers in retail store, and showcase only LCI product.



SOLERA UNIVERSAL SHADES AND ROOMS DEALER PROFIT PROGRAM

LCI Part #	Description	Qty.	Dealer Price	Program
3833980615	Solera Classic Shade - 15' Wide	1		
37978608	Solera Side Shade panel - 8' Drop	1		
3797820815	Solera Super Shade - 15' Wide 8' Drop	1		
3797820819	Solera Super Shade 19' Wide 8' Drop	1		
362221	Solera Screen Room 18' Wide	1		
711093	Solera Universal Shades and Rooms Wallpaper - 4'	1	FREE	FREE

Total:

SOLERA® UNIVERSAL REPLACEMENT FABRIC DEALER PROFIT PROGRAM



UNIVERSAL SLIDE TOPPER REPLACEMENT FABRIC

Stop wasting time by custom ordering slide topper fabric every time you get an order, and save room for more inventory! Our Slide Topper Replacement Fabric boxes are compact yet durable and are a universal fit, meaning no more guesswork when it comes to replacing slide topper fabric. Works with: Solera, Dometic®* and Carefree™**

FEATURES

- Our slide topper fabric is universal, fitting all three major slide topper brands
- Premium, 13.5 oz fabric - not the competition's 10 oz fabric
- Best of all, we offer a cut-to-fit option in a tissue-style box, complete with easy-to-use roller. Just extend out the amount of fabric you need and cut
- Roll stays in place with plastic reel (competitors do not offer this)

		Competitor A	Competitor B
Fits slide-outs ranging from 66" to 192" in length	✓	✓	✗
(1) Part number that comes complete with awning rail, topper and all mounting brackets	✓	✗	✗
Multiple colors and options available	✓	✗	✗
Premium 13.5 oz vinyl fabric	✓	✗	✗
No anti-billowing device needed	✓	✗	✗
Heated wedge welding fuses vinyl together for strong, leak-resistant seams	✓	✗	✗
Accommodates slide-outs up to 48" wide	✓	✗ 42"	✗ 42"
Flexible placement; can be installed up to five inches above slide box trim	✓	✗	✗

UNIVERSAL PATIO REPLACEMENT FABRICS

Solera's premium awning replacement fabric is head and shoulders above other brands with super heavy-duty materials, a 5-year warranty and heat-welded seams. Our canopy fabric also features an integrated light track so you can easily add the Solera Fabric Light Kit and enjoy LED lighting at the campsite. Best of all, get same day shipping if ordered by 12:00 EST.

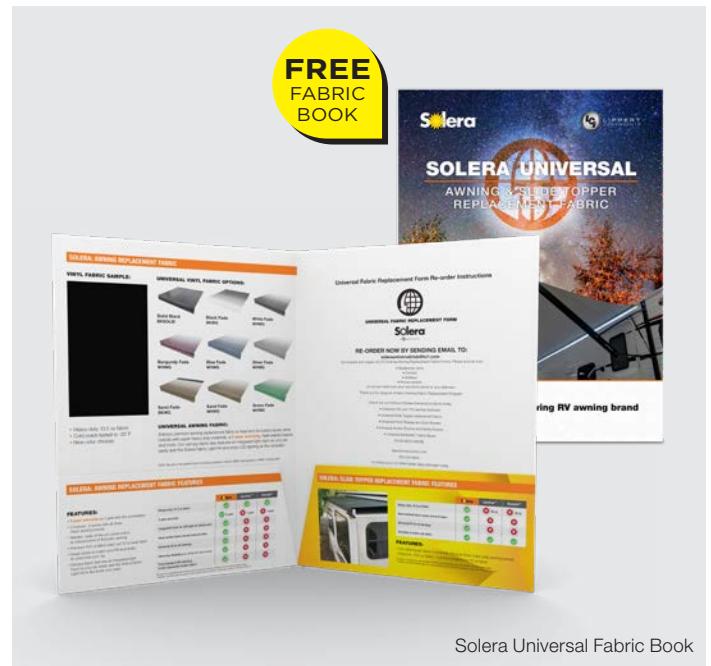

Solera Universal Fabric Book

FREE DISPLAY BOOK OPPORTUNITY!

Purchase a qualifying Solera product assortment and receive the FREE Solera Universal Fabric Display Book! As long as quantity of 4 is met, you will qualify for the program.

Limited time offer - while supplies last. Limit one display per dealership. Minimum order to qualify. Free qualifying display is to be kept clean, visible to consumers in retail store, and showcase only LCI product.

SOLERA UNIVERSAL CUT-TO-FIT DEALER PROFIT PROGRAM

LCI Part #	Description	Length	Qty.	Dealer Price	Program
432253	Universal Topper Replacement Fabric - Black	50'	2		
432252	Universal Topper Replacement Fabric - White	50'	2		
768207	Solera Universal Fabric Program Display Book		1	FREE	FREE

Total:

SOLERA® UNIVERSAL SLIDE TOPPERS DEALER PROFIT PROGRAM



PROTECT YOUR INVESTMENT.

Give your slide-outs extra protection from debris and water infiltration with Solera Universal Slide Toppers. These attractive and economical slide-out awnings automatically retract and extend with your slide-out and prevent leaves, bird droppings, branches and more from damaging slide-out seals.

FEATURES

- Attractive and economical protection for your slide-out
- Heated wedge welding fuses vinyl together for strong, leak-resistant seams
- Blocks leaves, bird droppings, branches and debris
- Automatically retracts and extends with slide-out
- Fits slides ranging from 66" to 192" long and extending up to 48"
- Comes complete with awning rail and all mounting brackets
- Premium 13.5 oz fabric

PREPPING OVER 160,000+ OEM SLIDE-OUTS IN 2019... AND THAT'S JUST THE START!

If you're not in the slide topper business, the new Solera Slide Topper Prep Program provides a fast and easy solution to Slide Topper Installation. Now is the time to get into the slide topper business and LCI is making it easier than ever.



Solera Slide Topper Spider Banner

FREE BANNER DISPLAY OPPORTUNITY!

Purchase a qualifying Solera product assortment and receive the FREE spider banner display! As long as quantity of 6 is met, you will qualify for the program.

Limited time offer - while supplies last. Limit one display per dealership. Minimum order to qualify. Free qualifying display is to be kept clean, visible to consumers in retail store, and showcase only LCI product.

SOLERA UNIVERSAL SLIDE TOPPER DEALER PROFIT PROGRAM

LCI Part #	Description	Width	Flange Measurement	Qty.	Dealer Price	Program
V000165062	Solera Slide Topper Black/Black	85"	80" - 85"	2		
V000168106	Solera Slide Topper Black/Black	91"	86" - 91"	1		
V000165061	Solera Slide Topper Black/Black	151"	146" - 151"	2		
V000168109	Solera Slide Topper Black/Black	157"	152" - 157"	1		
711096	Solera Universal Slide Topper Spider Banner			1	FREE	FREE

Total:

SOLERA® UNIVERSAL AWNBRELLA™ DEALER PROFIT PROGRAM

SOLERA AWNINGS



EXTRA AWNING SUPPORT.

Perfect for destination campers who like to leave the awning extended for long periods, the patented rust-resistant aluminum bows hold fabric taut and arched so water doesn't pool and debris can easily run off. Now your customers won't have to camp with one end of their awning pitched lower than the other. The Solera Awmbrella also complements the Solera Screen Room and Solera Family Room®.

FEATURES

- Adjustable rust-resistant aluminum bows
- Keeps canopy from flapping in the wind
- Increases clearance over entry door
- Prevents canopy from sagging
- Stops water from pooling
- Enhances appearance



Solera Awmbrella Display

FREE PRODUCT DISPLAY OPPORTUNITY!

Purchase 8 boxes and receive the FREE Awmbrella product display! As long as quantity is met, you will qualify for the program.

Limited time offer - while supplies last. Limit one display per dealership. Minimum order to qualify. Free qualifying display is to be kept clean, visible to consumers in retail store, and showcase only LCI product.

SOLERA UNIVERSAL AWNBRELLA DEALER PROFIT PROGRAM

LCI Part #	Description	Qty.	Dealer Price	Program
362238	Solera 8' Awmbrella, 2-pack	4		
362237	Solera 8' Awmbrella, 3-pack	4		
423078	Solera Universal Awmbrella Floor Display	1	FREE	FREE

Total:



QUALIFICATIONS TO JOIN

Purchase the following 2 programs:

- Solera Universal Slide Topper
- Solera Universal Hardware

PROGRAM BENEFITS

In addition to individual program benefits you also receive:

- 4-sided Solera Universal Showroom Display



Solera Universal 4-Sided Display

FREE DISPLAY OPPORTUNITY!

Purchase a qualifying Solera product assortment and receive the FREE 4-sided corrugate display! As long as both programs are purchased, you will qualify for the program.

Limited time offer - while supplies last. Limit one display per dealership. Minimum order to qualify. Free qualifying display is to be kept clean, visible to consumers in retail store, and showcase only LCI product.

SOLERA UNIVERSAL CLUB DEALER PROFIT PROGRAM

LCI Part #	Description	Qty.	Dealer Price	Program
	Solera Universal Slide Topper Program	1		
	Solera Universal Hardware Program	1		
768210	Solera Universal 4-Sided Display	1	FREE	FREE
			Total:	



STABLE. STURDY. SOLID.

The Solid Step®'s innovative design permits the step to operate through a wide range of ride heights. The design also ensures that the steps stay parallel to the ground, reducing the potential for slipping or falling during use. The Solid Step® design permits the step to stow inside of the entry door, keeping road debris and corrosion away while simultaneously permitting continuous skirt metal on the RV, enhancing the aesthetics of the coach.

- No bounce, manual steel step with aluminum treads
- Threshold panel behind the top step to protect the trailer sidewall from damage
- Recessed feet prevent trip hazard and maximize clearance for camping spot
- 13" XL top step depth for easy entry and exit
- Aluminum treads that hold up against the elements
- Mounting fasteners provided for either wood or laminate floor applications
- Double, triple and quad variations available
- 400-pound capacity
- Includes floor backing plate

SOLID STEP® GEN. 3 ENTRY STEP & ACCESSORIES DEALER PROFIT PROGRAM



LIFT ASSIST UPGRADE KIT

- The Lift Assist strut keeps the Solid Step® from dropping completely when disengaged from the door-jamb
- The heavy-duty gas strut system that takes the weight off of the Solid Step® makes it virtually weightless when it is released to the ground or raised for storage
- Lowering or raising the Solid Step® with Lift Assist can even be done with one finger
- Only available for Gen 3 Triple and Quad Solid Step®



ALL-WEATHER FLOOR TRAY

- Heavy-duty recycled rubber mat construction won't slide around while in transit
- Neatly catches water, leaves, dirt and other debris from your Solid Step®
- Multi-purpose storage solution for dirty shoes or pet dishes, keeping your RV clean



ENTRY ASSIST HANDRAIL

- No need to remove the handrail during storage, floor plan allowing; locking pins always keep the handrail in its proper, secured position
- Powder coat finish stands up to the elements
- Mounting brackets and installation hardware for included DIY installation
- Adjustable height for best positioning
- Only available for Gen 3 Triple and Quad Solid Step®

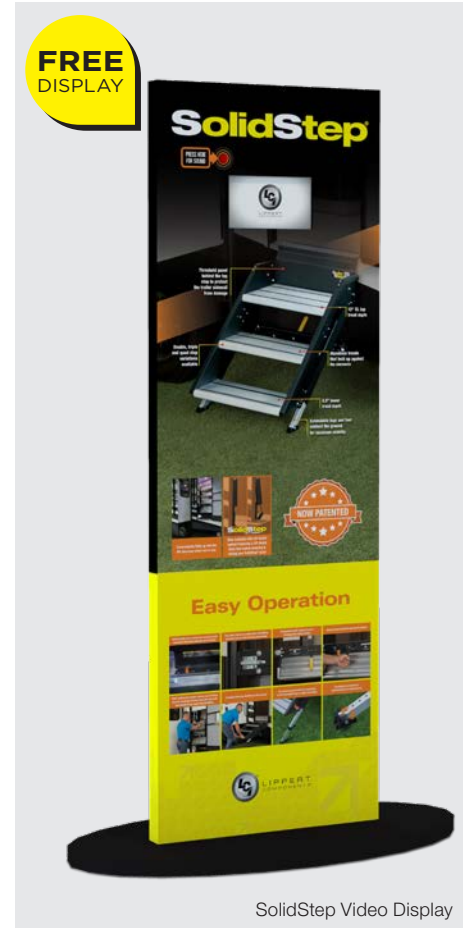

SolidStep Video Display

FREE DISPLAY OPPORTUNITY!

Purchase the Solid Step® Dealer Profit Program and receive the Solid Step display with video/audio for FREE!

Limited time offer - while supplies last. Limit one display per dealership. Minimum order to qualify. Free qualifying display is to be kept clean, visible to consumers in retail store, and showcase only LCI product.

SOLID STEP® GEN. 3 ENTRY STEP & ACCESSORIES DEALER PROFIT PROGRAM

LCI Part #	Description	Frame Width*	Qty.	Dealer Price	Program
733931	26" Premium Double Solid Step Gen 3	25"-28"	1		
733932	30" Premium Double Solid Step Gen 3	29"-36"			
791572	26" Premium Triple Solid Step Gen 3	25"-28"			
791573	30" Premium Triple Solid Step Gen 3	29"-36"	1		
791574	26" Premium Quad Solid Step Gen 3	25"-28"			
791575	30" Premium Quad Solid Step Gen 3	29"-36"	1		
733937	Narrow Lift Assist Kit for Solid Step	25"-28"	1		
733939	Wide Lift Assist Kit for Solid Step	29"-32"	1		
799640	Solid Step Handrail for Triple and Quad Gen 3 Steps		6		
801380	Solid Step All-Weather Floor Tray		10		
768206	Solid Step Dealer Profit Program Display with video/audio		1	FREE	FREE

Total:

*Frame Width - Measure frame to frame at bottom of door or threshold length. Lift Assist cannot be installed on frame widths above 32"



DISCOVER A BETTER WAY TO HAUL YOUR GEAR.

When the trails call, hitch your bike to a rack made for your RV and your lifestyle. With over 20 years of industry experience, Let's Go Aero, Inc. combines a passion for the outdoors with innovative designs and technology to get you and your biking gear to every destination, safe and sound. From eliminating carrier sway on the back of your trailer to developing a rack you can see from your rearview mirror — every detail of every product is engineered to meet the needs of riders like you hitting the open road. And as a distribution partner, Lippert Components proudly offers a wide variety of top-shelf storage solutions, bike racks, cargo carriers, and utility and towing equipment made exclusively by the team at Let's Go Aero.



- BikeWing® & BikeBase™ (Hitch-IT)
- BikeWing® & Bump-IT™
- BikeWing®, Stinger & PowerTower™ (Jack-IT®)

JACK-IT® BIKE SOLUTIONS DEALER PROFIT PROGRAM



BUMP-IT™



Bike Base



HITCH-IT



BIKEWING™

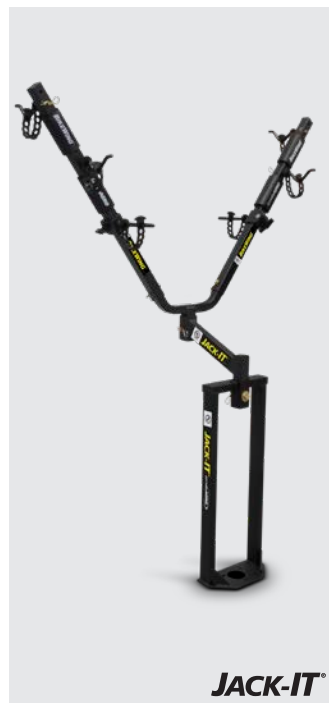

JACK-IT™

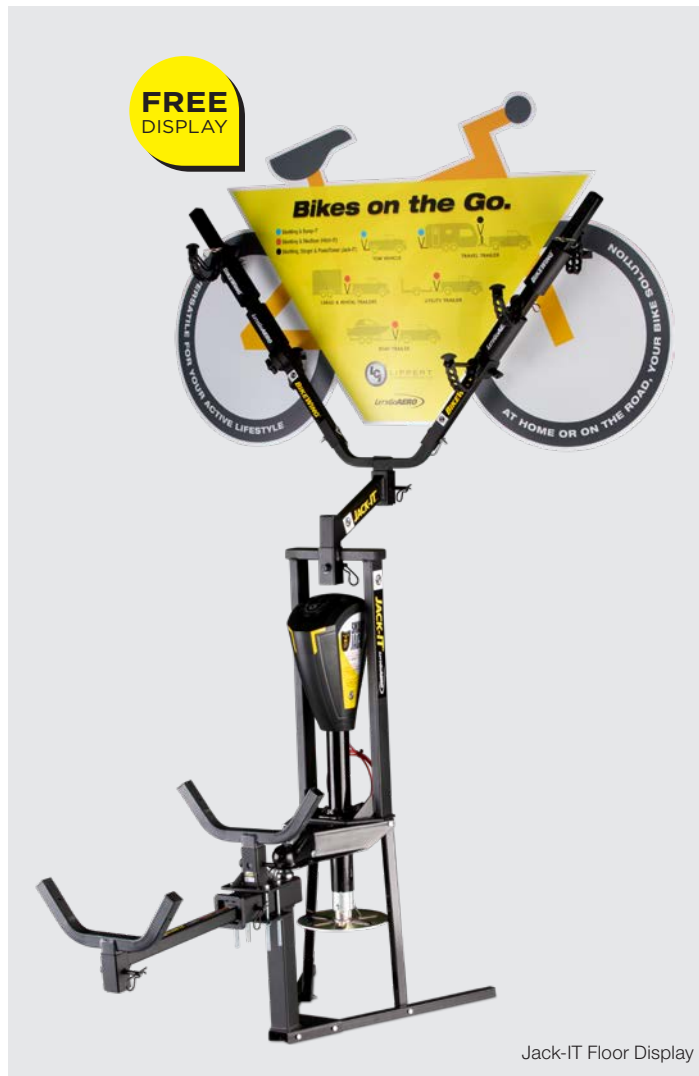

Jack-IT Floor Display

STEPS & JACKS

TAKE YOUR BIKES WHEREVER YOU GO.

Give your customers the newest and most innovative products from Lippert Components. The new Let's Go Aero product line gives your customers a variety of bike mounting accessories and options so they can take their bikes wherever they go.

FREE FLOOR DISPLAY OPPORTUNITY!

Purchase the Jack-IT Bike Solutions Dealer Profit Program and receive the floor display for FREE!

Limited time offer - while supplies last. Limit one display per dealership. Minimum order to qualify. Free qualifying display is to be kept clean, visible to consumers in retail store, and showcase only LCI product.

JACK-IT BIKE SOLUTIONS DEALER PROFIT PROGRAM

LCI Part #	Description	Qty.	Dealer Price	Program
429756	Jack-IT Bike Carrier	5		
723359	Bump-IT Receiver Adapter	3		
731137	BikeWing 2-Bike Carrier	1		
731138	Hitch-IT BikeBase/BikeWing Combo	1		
731157	BikeBase A-Frame Adapter	1		
643589	Smart Jack Power Tongue Jack	1		
656439	Jack-IT Bike Solutions Profit Program Floor Display	1	FREE	FREE
Total:				

MANUAL STEP DEALER PROFIT PROGRAM

STEPS & JACKS



Alumi-Tread Quad Step



Alumi-Tread Triple Step



24" Manual Radius Triple Step



24" Manual Radius Double Step



YOUR #1 STEP SOLUTION MANUAL - POWER - SOLID



THE LAST STEP YOU'LL EVER NEED.

We offer a complete line of premium manual RV steps including our lightweight hybrid Alumi-Tread Step® featuring strong steel linkage and attractive aluminum treads as well as our Manual Radius Steps featuring a powder-coated finish, compact design and available in single, double, triple and quad configurations.

FREE WALLPAPER DISPLAY OPPORTUNITY!

Purchase the Manual Step Dealer Profit Program and receive the 4' planogram wallpaper for FREE!

Limited time offer - while supplies last. Limit one display per dealership. Minimum order to qualify. Free qualifying display is to be kept clean, visible to consumers in retail store, and showcase only LCI product.

FREE WALLPAPER



Manual Steps Wallpaper

MANUAL STEP DEALER PROFIT PROGRAM

LCI Part #	Description	Qty.	Dealer Price	Program
432678	24" Radius Single Steel Step - Manual	1		
432682	24" Radius Double Steel Step - Manual	1		
432687	24" Radius Triple 7" Steel Step - Manual	1		
432690	24" Radius Triple 9" Steel Step - Manual	1		
432696	Alumi-Tread Triple 9 Step - Hybrid			
432698	Alumi-Tread Quad Step - Hybrid	1		
711101	Manual Step Dealer Profit Program Wallpaper - 4'	1	FREE	FREE

Total:

TONGUE JACK DEALER PROFIT PROGRAM



Replacement Override Plugs

NO MORE CRANKING.

The Lippert Components Tongue Jack Profit Program gives you everything you need to sell a variety of tongue jack options. Each tongue jack product comes in LCI branded, eye-catching packaging that will jump off your shelf!



FREE FLOOR DISPLAY OPPORTUNITY!

Purchase a qualifying combination of Tongue Jack products and receive the floor display for FREE!

Limited time offer - while supplies last. Limit one display per dealership. Minimum order to qualify. Free qualifying display is to be kept clean, visible to consumers in retail store, and showcase only LCI product.

TONGUE JACK DEALER PROFIT PROGRAM

LCI Part #	Description	Qty.	Dealer Price	Program
285318	Power Tongue Jack - Black	6		
643589	Smart Jack Power Tongue Jack	4		
733926	Quick Drop Manual Tongue Jack	4		
733924	Override Plug for Power Tongue Jack (Pair)	6		
733925	Override Plug for Smart Jack (Pair)	6		
688492	Tongue Jack Profit Program Floor Display	1	FREE	FREE

Total:

GROUND CONTROL® LEVELING DEALER PROFIT PROGRAM

NEXT LEVEL RVING.

Lippert Components has developed a range of leveling and stabilization solutions to enhance every RV set up. We've made it faster, easier and simpler to get your RV up and running at the campsite and to maintain a stable and safe foundation for the RV lifestyle. From automatic leveling systems to power stabilizer jacks and stabilization accessories, we've got you covered.



Ground Control 3.0 Leveling

ONE-TOUCH FIFTH-WHEEL LEVELING

With the push of a button, Ground Control® 3.0 levels and stabilizes the RV in a matter of minutes and features automatic re-hitch smart memory that saves the exact height at which the RV unhitched, saving RVers time when hooking up.



Ground Control TT Leveling

ONE-TOUCH TRAVEL TRAILER LEVELING

Ground Control® TT is the first ever automatic one-touch leveling system designed for travel trailer RVs. Long gone are the days of cranking manual jacks and using chocks and wedges to level your travel trailer. Four leveling jacks as well as the power tongue jack level your trailer accurately every time. Manual setup is now a thing of the past!

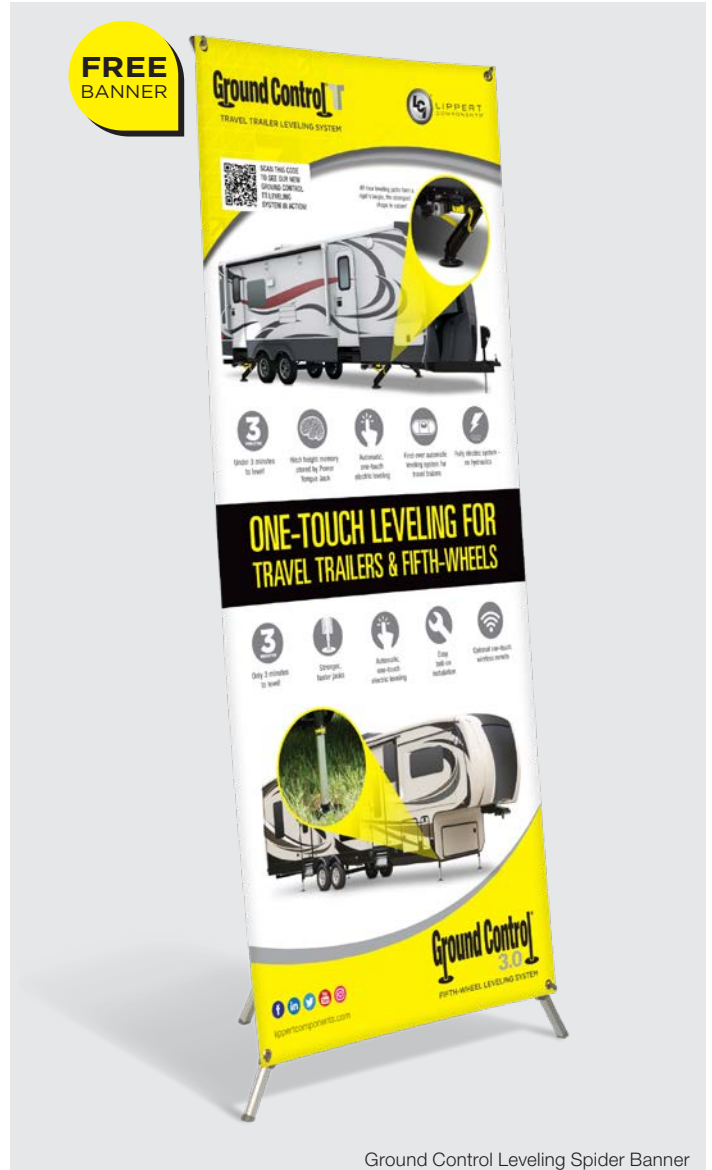

Ground Control Leveling Spider Banner

FREE BANNER DISPLAY OPPORTUNITY!

Purchase one of either Ground Control® kits, and get the spider banner display for FREE!

Limited time offer - while supplies last. Limit one display per dealership. Minimum order to qualify. Free qualifying display is to be kept clean, visible to consumers in retail store, and showcase only LCI product.

GROUND CONTROL® LEVELING SYSTEM DEALER PROFIT PROGRAM

LCI Part #	Description	Qty.	Dealer Price	Program
672136	Ground Control TT - Travel Trailer Leveling	1		
358590	Ground Control 3.0 - Fifth-Wheel Leveling Four-Point 15.5K			
675817	Ground Control 3.0 - Fifth-Wheel Leveling Six-Point 15.5K			
711091	Ground Control Leveling System Spider Banner	1	FREE	FREE

Total:



JT Strong Arm



JT Strong Arm Travel Trailer Kit

PUT AN END TO UNWANTED CHASSIS MOVEMENT

Each JT's Strong Arm stabilizer tube bolts on to each landing gear leg and to the RV frame, forming a rigid triangle to eliminate unwanted chassis movement and provide a rock-solid camping experience, no welding required. The patented universal system is designed to attach to the three main types of jacks found on RVs: scissor, front landing gear and telescoping. JT's Strong Arm Jack Stabilizers come in easy bolt-on kits of four or six stabilizer tubes and include everything needed for installation.

FEATURES

- Eliminates annoying chassis movement
- Provides a rock steady camping experience
- One-time installation/permanently attached
- Works with all types of jacks
- Bolt-on installation — No welding required
- Includes 6 stabilizer bars plus all hardware



FREE WALLPAPER



Stabilization Wallpaper

FREE WALLPAPER DISPLAY OPPORTUNITY!

Purchase the JT's Strong Arm Dealer Profit Program and receive the 4' planogram wallpaper for FREE!

Limited time offer - while supplies last. Limit one display per dealership. Minimum order to qualify. Free qualifying display is to be kept clean, visible to consumers in retail store, and showcase only LCI product.



LEVELING & STABILIZATION

JT'S STRONG ARM DEALER PROFIT PROGRAM

LCI Part #	Description	Qty.	Dealer Price	Program
191023	JT's Strong Arm Jack Stabilizer Kit, 5th Wheel, Over 58"	2		
191025	JT's Strong Arm Jack Stabilizer Kit, Travel Trailer	2		
314594	T-Bolt for JT Strongarm (2 Pack)	4		
314602	T-Bolt Tightening Tool (27 1/2")	2		
768219	Stabilization Profit Program Wallpaper - 4'	1	FREE	FREE

Total:



Trailair Pin Boxes



Trailair Pin Box Display

FIFTH-WHEEL TOWING SOLUTIONS

Fifth-wheel RV owners know all too well the perils of towing down bumpy roads. The Trailair® Pin Box Profit Program features a complete line of fifth-wheel towing solutions to cover the novice weekend RVer and the full-time RVer who demands nothing but the best towing experience.

FREE PIN BOX DISPLAY OPPORTUNITY!

Purchase a quantity of 1 pin box and you will qualify for the program. Display program available for a limited time.

Limited time offer - while supplies last. Limit one display per dealership. Minimum order to qualify. Free qualifying display is to be kept clean, visible to consumers in retail store, and showcase only LCI product.

TRAILAIR® PIN BOX DEALER PROFIT PROGRAM

LCI Part #	Description	Qty.	Dealer Price	Program
328484	M15 18K Flex Air Pin Box, Medium Jaw			
328492	L05 18K Flex Air Pin Box, Long Jaw			
369535	21K Flex Air Pin Box, Long Jaw	1		
179879	M15 HD Air Ride Pin Box, 18K (Replaces LCI 0719 Pin Box)			
158778	Long Jaw Air Ride Pin Box, 21K (Replaces LCI 1621 Pin Box)			
155943	M19 Air Ride Pin Box, 21K (Replaces LCI 1116 Pin Box)			
328330	Rota-Flex 1621 Pin Box, 18K - Formerly 160468			
176440	Rota-Flex 1116 Pin Box, 19K			
328329	Rota-Flex 1621SHD Pin Box, 21K			
768198	Trailair Pin Box Display with video/audio	1	FREE	FREE
			Total:	



Sway Command



Red light indicator tells the driver when Sway Command is activated

TOW CONTROL TECHNOLOGY

We all know how scary a travel trailer sway event can be, especially when making emergency maneuvers at high speeds. A weight distribution hitch with sway control bars will help in minor sway events, but that's not enough! Our Sway Command® Tow Control Technology promotes safety by applying the trailer brakes before a major sway event can get out of control.

FEATURES

- Utilizes both an accelerometer (measures lateral force) and gyroscope (measures angular velocity) to quickly and accurately differentiate between side-to-side and up-and-down movement to prevent false activation. This is especially useful off road. The competition uses only accelerometer technology.
- Advanced patent pending microprocessor technology electronically detects trailer sway and applies the trailer brakes to suppress unwanted sway.
- Light pod mounts to the front of the trailer and signals to the driver when the system is functioning properly.
- Rigorously tested in sway-inducing towing conditions, including emergency maneuvers.
- Controller works independently from existing brake control so that in the case of a short or disconnect in the tow vehicle connection, Sway Command® won't be affected or vice versa.



Sway Command Counter Top Display

FREE COUNTER DISPLAY OPPORTUNITY!

Purchase 6 Sway Command® Tow Control Technology modules and receive the counter top display for FREE!

Limited time offer - while supplies last. Limit one display per dealership. Minimum order to qualify. Free qualifying display is to be kept clean, visible to consumers in retail store, and showcase only LCI product.

LEVELING & STABILIZATION

SWAY COMMAND® DEALER PROFIT PROGRAM

LCI Part #	Description	Qty.	Dealer Price	Program
380605	Sway Command Kit	6		
695361	Sway Command Profit Program Counter Top Display Box	1	FREE	FREE
Total:				

STABILIZATION DEALER PROFIT PROGRAM **NEW**

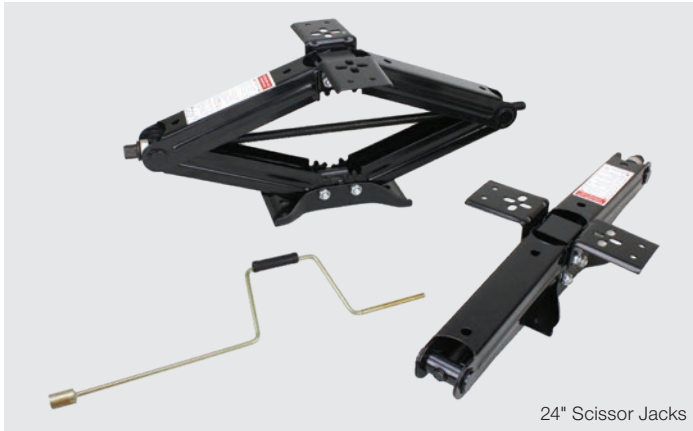

24" Scissor Jacks

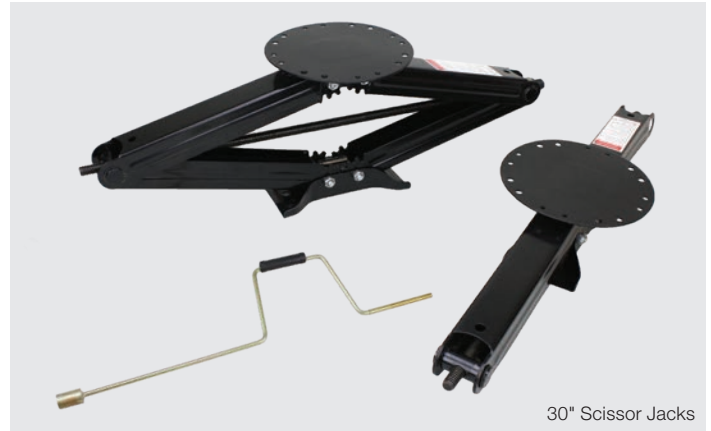

30" Scissor Jacks

STABILIZE YOUR RV OR TRAILER

Lippert Components 24-inch and 30-inch lift scissor jacks provide a cost-efficient way to stabilize your RV or trailer. LCI manual scissor jacks feature easy bolt-on installation and powder-coated, rust-inhibitive finish. Each kit contains two scissor jacks, mounting hardware and manual crank handle.

FEATURES

- Easy and inexpensive way to add stabilization to your RV in order to reduce rocking and swaying
- Heavy gauge steel scissor jacks manually raise and lower with crank handle and add stability to RV fifth-wheel or travel trailer
- 24" rise or 30"
- Easy bolt-on installation; mounting hardware included
- Powder-coated, rust-inhibitive surfaces

LEVELING & STABILIZATION

FREE WALLPAPER



Stabilization Wallpaper

FREE WALLPAPER DISPLAY OPPORTUNITY!

Purchase the Stabilization Dealer Profit Program and receive the 4' planogram wallpaper for FREE!

Limited time offer - while supplies last. Limit one display per dealership. Minimum order to qualify. Free qualifying display is to be kept clean, visible to consumers in retail store, and showcase only LCI product.



STABILIZATION DEALER PROFIT PROGRAM

LCI Part #	Description	Qty.	Dealer Price	Program
285325	24" Scissor Jack Kit (Single)			
285326	24" Scissor Jack Kit with Crank Handle (Pair)	32		
285332	30" Scissor Jack Kit (Single)			
285344	30" Scissor Jack Kit with Crank Handle (Pair)			
768219	Stabilization Profit Program Wallpaper - 4'	1	FREE	FREE
			Total:	



Power Stabilizer



HIGH-SPEED STABILIZATION

The PSX1® High-Speed Power Stabilizer by Lippert Components lets you do the one thing you want most – spend more time camping, and less time setting up for camp. With the flip of a switch, you can take the sway out of your RV or trailer in minutes. No more manual cranking. No more hassle.

Uneven terrain? No problem. Each leg of our stabilizer operates independently — automatically reacting to bumpy, rugged surfaces until the RV is secured safely in place. Plus, our PSX1 Power Stabilizers are compatible with most RVs and trailers on today’s market.

FEATURES

- Legs automatically adjust to uneven terrain
- Front and rear mounting applications available for maximum stability
- Constructed with a heavy gauge steel frame
- Embossed legs for added protection
- Powder-coat finish to reduce wear and tear from the elements
- One motor independently controls both legs
- Legs extend up to 30"



Stabilization Wallpaper

FREE WALLPAPER DISPLAY OPPORTUNITY!

Purchase the Stabilization Dealer Profit Program and receive the 4' planogram wallpaper for FREE!

Limited time offer - while supplies last. Limit one display per dealership. Minimum order to qualify. Free qualifying display is to be kept clean, visible to consumers in retail store, and showcase only LCI product.

LEVELING & STABILIZATION

POWER STABILIZER DEALER PROFIT PROGRAM

LCI Part #	Description	Qty.	Dealer Price	Program
298707	Electric Stabilizer with Black Waterproof Switch	2		
673594	Power Stabilizer Bolt-on Double Spacer Kit (4 spacers)	2		
352338	Power Stabilizer Replacement Motor	1		
768219	Stabilization Profit Program Wallpaper - 4'	1	FREE	FREE
			Total:	



GET UP TO 50% BETTER BRAKING DISTANCE!



Trailer Equipped with Forward Self-Adjusting Brakes



Trailer Equipped with Standard Electric Brakes

Stopping distance at 60 MPH

BE PREPARED FOR EMERGENCY STOPS

Did you know standard brakes should be adjusted every 3 months or 3,000 miles? Forward Self-Adjusting Brakes self-adjust during every forward stop, providing up to 50 percent better braking distance and preventing premature brake line and magnet wear.



297956



298275



296649

FREE
WALLPAPER

FREE WALLPAPER DISPLAY OPPORTUNITY!

Purchase the Brake Assembly Dealer Profit Program and receive the 4' planogram wallpaper for FREE!

Limited time offer - while supplies last. Limit one display per dealership. Minimum order to qualify. Free qualifying display is to be kept clean, visible to consumers in retail store, and showcase only LCI product.

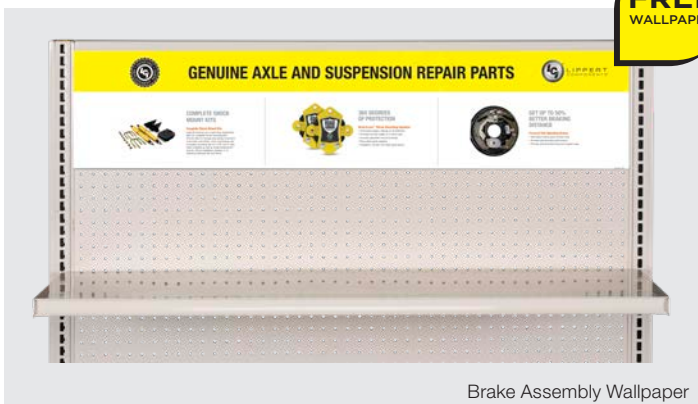

Brake Assembly Wallpaper

BRAKE ASSEMBLY DEALER PROFIT PROGRAM

LCI Part #	Description	Qty.	Dealer Price	Program
296649	10" X 2.25" LH Electric Self Adjusting Brake Assy, 3.5K	4		
296650	10" X 2.25" RH Electric Self Adjusting Brake Assy, 3.5K	4		
296651	12" X 2" LH Electric Self Adjusting Brake Assy, 7.0K	4		
296652	12" X 2" RH Electric Self Adjusting Brake Assy, 7.0K	4		
297956	10" X 2.25" LH Electric Brake Assy, 3,500 Lbs.	2		
298274	10" X 2.25" RH Electric Brake Assy, 3,500 Lbs.	2		
298275	12" X 2" LH Electric Brake Assy, 7,000 Lbs.	2		
298276	12" X 2" RH Electric Brake Assy, 7,000 Lbs.	2		
768226	Brake Assembly Profit Program Wallpaper - 4'	1	FREE	FREE

Total:

NEW SLIDE-OUT REPAIR PARTS DEALER PROFIT PROGRAM



287298



364262



118246



211852



320500



281331

Slide-outs are a main mechanical part of the RV that require constant upkeep, maintenance and repairs. Our Slide-Out Repair Parts Dealer Profit Program keeps your service team stocked with fast moving slide-out repair and maintenance parts to keep your customers camping in the great outdoors and not in your waiting area. Load up on motors, gears, wiring harnesses and more and be prepared for when your customers need to be taken care of.

FREE WALLPAPER

FREE WALLPAPER DISPLAY OPPORTUNITY!

Purchase the Slide-Out Repair Parts Dealer Profit Program and receive the 4' planogram wallpaper for FREE!

Limited time offer - while supplies last. Limit one display per dealership. Minimum order to qualify. Free qualifying display is to be kept clean, visible to consumers in retail store, and showcase only LCI product.

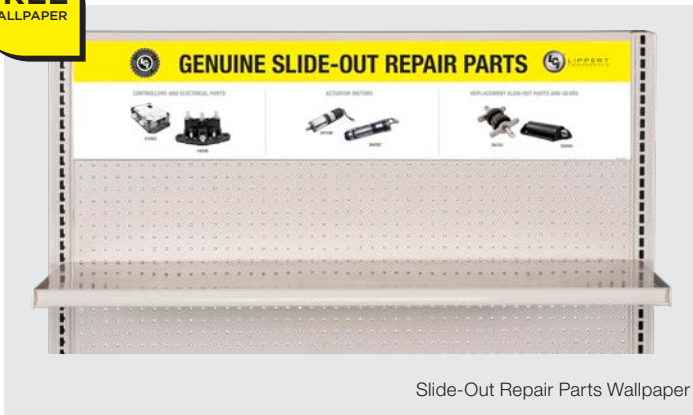

Slide-Out Repair Parts Wallpaper

SLIDE-OUT REPAIR PARTS DEALER PROFIT PROGRAM

LCI Part #	Description	Qty.	Dealer Price	Program
236575	Slide-Out Motor, IG-42 Motor - 10mm	2		
287298	Slide-Out Motor, 500:1 - High Torque	1		
364262	Slide-Out Motor, In-wall, 42mm - Mid Torque	1		
320500	J38 Roller for In-Wall Slide-Out	2		
103480	Universal LCI Slide-Out Wear Pad	6		
281331	2 x 2 Slide-Out Gear Pack	2		
177094	Hydraulic Cartridge Valve	1		
138416	Hydraulic Hose End Fitting-JIC, Crimp-on Coupling	6		
118246	Dual Polarity Solenoid-Silver/Bronze Allo Posts	1		
211852	In-Wall Slide-Out Controller, V-Sync II	1		
229755	20' Wiring Harness	2		
238991	25' Wiring Harness	2		
120639	Interior In/Out Switch and Plate	1		
1346271	Single Flex Guard Kit	1		
1346281	Double Flex Guard Kit	1		
1346291	Triple Flex Guard Kit	1		
134993	Slide-Out Slicker (Pair)	4		
811738	Slide-Out Repair Parts Dealer Profit Program Wallpaper - 4'	1	FREE	FREE

Total:

REPAIR AND REPLACE



SEAL YOUR BUSINESS WITH ALPHA/LCI TODAY!

As you drive across America, 4 out of every 5 RV's you encounter will have a TPO Roof. That's nearly 1.7 million TPO protected RV's. With more than 500 million square feet – or nearly 18 square miles – of SUPERFLEX TPO in service, it's by far the first choice of RV manufacturers. Don't void your customer's warranty by using imposter products. Only use Alpha on Alpha.

Lippert Components now proudly distributes the full suite of Alpha Systems, LLC's products! Alpha's water-based adhesive and solvent-based sealants have been specifically engineered to provide premium performance and flexibility for the demanding roof designs of today's RVs. What's more, using Alpha Systems products won't void your warranty. Lab tested. Road proven.

SEALANTS

Alpha's complete line of advanced adhesives and sealants that stand up to extreme weather, ozone, UV rays and vibrations, include all-weather sealants, solvent-based and water-based adhesives.

BUTYL TAPES

Alpha's butyl tape solutions install quickly and without gaps, assuring for a seamless installation, whether it be on an RV or metal building. Alpha's butyl tapes feature a non-drying compound that has excellent resistance to water, weather, and air intrusion.

ROOFING

The Alpha SuperFlex TPO roofing membrane is used in conjunction with Alpha's water-based adhesive and solvent-based sealants, having been specifically engineered to provide premium performance and flexibility for the demanding roof designs of today's RV. All colors provide excellent UV protection and have color-coordinating sealants.

FREE STORE DISPLAY OPPORTUNITY!

Purchase the Alpha Systems Dealer Profit Program and receive the display for FREE! Display program available for a limited time.

Limited time offer - while supplies last. Limit one display per dealership. Minimum order to qualify. Free qualifying display is to be kept clean, visible to consumers in retail store, and showcase only LCI product.



ALPHA SYSTEMS DEALER PROFIT PROGRAM

LCI Part #	Description	Color	Qty.	Dealer Price	Program
Self-Leveling Sealants					
862144	1021 White UPC Low-VOC Self-Leveling Sealant-Tube	White	36		
862147	1021 Grey UPC Low-VOC Self-Leveling Sealant-Tube	Grey	12		
862148	1021 Beige UPC Low-VOC Self-Leveling Sealant-Tube	Beige	12		
862149	1021 Almond UPC Low-VOC Self-Leveling Sealant-Tube	Almond	12		
862215	5121 White Alphathane 100% Solids Self-Leveling Tube	White	12		
Non-Sag Sealants					
862157	1010 White UPC Non-Sag Sealant	White	12		
862159	1010 Grey UPC Non-Sag Sealant	Grey	12		
862160	1010 Beige UPC Non-Sag Sealant	Beige	12		
862161	1010 Almond UPC Non-Sag Sealant	Almond	12		
All Purpose Sealants					
862224	N2100 All Purpose RV Sealant	Clear	12		
RV Adhesives and Roof Coatings					
862399	8010 Water-based Adhesive (1-Gallon)		2		
862400	8019 Adhesive (1 Gallon)		2		
862401	4034 White Latex Roof Coating (1-Gallon)		2		
Butyl And Tapes					
862403	Q130 1/8" x 3/4" x 30' Butyl Tape Bulk (20ct)		1		
862405	Q130 1/8" x 3/4" x 35' Butyl Tape Clam Shell		8		
862406	Alphabond TPO Tape 3"X50' Black	Black	1		
862408	Alphabond TPO Tape 3"X50' White	White	1		
862409	Alphabond TPO Tape 4"X10' Repair Tape-Black- Clam Shell	Black	5		
862410	Alphabond TPO Tape 4"X10' Repair Tape-White- Clam Shell	White	5		
Cleaners					
862414	RV Roof Cleaner		12		
Roof and Patch Kits					
862449	Superflex Patch Kit Almond - 6.0 Sf	Almond	1		
862452	Superflex Patch Kit White - 6.0 Sf	White	2		
862422	RV Roof Kit - Superflex White	White	1		
	Alpha Systems Dealer Profit Program Display		1	FREE	FREE

Total:

COLOR SAMPLES*

All colors provide excellent UV protection and have color-coordinating sealants and adhesives.

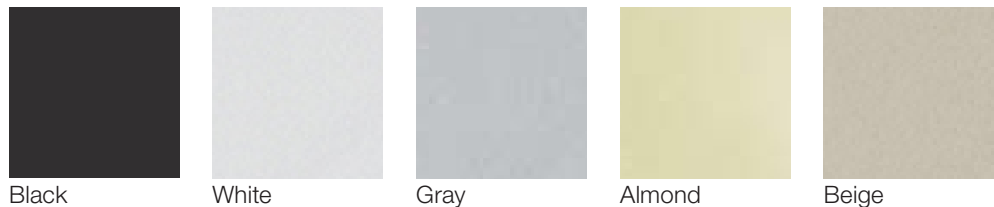

* The above colors are samples. Due to printing, the colors portrayed may not be accurate reproductions of actual product colors.

REPAIR AND REPLACE

AXLE AND SUSPENSION REPAIR PARTS DEALER PROFIT PROGRAM NEW



Road Armor Equalizers



Shock Mount Kits



Never Fail Bushings



Brake Hubs



Grease Seals

FULL 360 DEGREES OF PROTECTION.

Introducing the Road Armor™ Shock Absorbing Equalizer, built on our legendary Trailair® anti-shock technology. The patent pending Road Armor dampens road shock and vibrations transferred from both the leading and trailing trailer axle leaf springs.

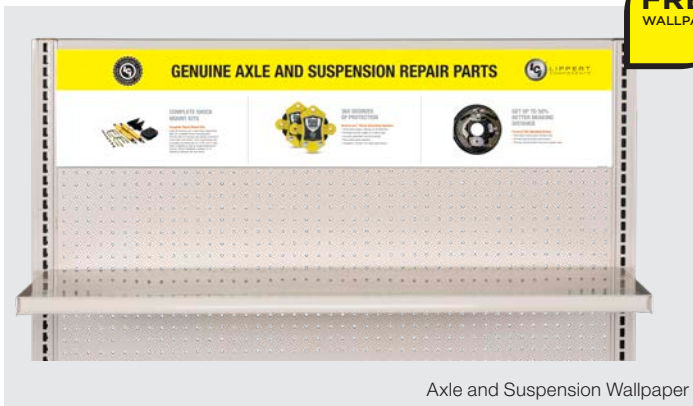

Axle and Suspension Wallpaper

FREE WALLPAPER DISPLAY OPPORTUNITY!

Purchase the Axle and Suspension Repair Parts Dealer Profit Program and receive the 4' planogram wallpaper for FREE!

Limited time offer - while supplies last. Limit one display per dealership. Minimum order to qualify. Free qualifying display is to be kept clean, visible to consumers in retail store, and showcase only LCI product.

AXLE AND SUSPENSION REPAIR PARTS DEALER PROFIT PROGRAM

LCI Part #	Description	Qty.	Dealer Price	Program
281281	Shock Mount Replacement Kit-3" Axle Tube	1		
281255	Shock Mount Replacement Kit-2 3/8" Axle Tube	1		
696740	Road Armor Tandem Axle Equalizer Kit	1		
281285	Never Fail Shackle, Bolt, and Bushing Kit - Double Axle	2		
281288	Never Fail Shackle, Bolt, and Bushing Kit - Triple Axle	1		
814200	Brake Hub - 3500 lbs	1		
814202	Brake Hub - 5200-6000 lbs	2		
814203	Brake Hub - 6000-7000 lbs	1		
693722	Rubber Insert for Lubed Dust Caps - Universal (2000-8000# axles) (10/pkg)	1		
333961	Grease seal, 3500#, 1.719" ID, 2.565" OD (10/pkg)	1		
333963	Grease seal, 5200#-8000#, 2.25 ID (10/pkg)	1		
811739	Axle and Suspension Repair Parts Dealer Profit Program Wallpaper - 4'	1	FREE	FREE

Total:

STEP AND CHASSIS CARE DEALER PROFIT PROGRAM



Kwik Lube



Chassis Shield



Step Tread

KWIK LUBE SPRAY LUBRICANT

- Great for RVs
- Leveling Systems
- Tongue Jacks
- Ramp Doors
- Slide-Outs
- Steps

CHASSIS SHIELD® RUST INHIBITOR

- Creates a thin film to protect RV and trailer chassis from rust and corrosion
- Penetrates and lubricates to free rusted, stuck parts and eliminate squeaks
- Approved for sale in California and Canada
- Displaces water on metal surfaces
- Lubricates moving parts
- Made in the USA

STEP TREAD REPLACEMENT

This product utilizes a luminescent system, which glows in the dark once it has been exposed to natural or artificial light. This product will glow the brightest during the first 30 minutes, after activation has ceased, and will remain visible to the night darkness adapted eye for up to 10 hours.

**FREE
DISPLAY**



Step and Chassis Care Counter Top Display

FREE COUNTER TOP DISPLAY OPPORTUNITY!

Purchase the Step And Chassis Care Dealer Profit Program and receive the counter display box for FREE!

Limited time offer - while supplies last. Limit one display per dealership. Minimum order to qualify. Free qualifying display is to be kept clean, visible to consumers in retail store, and showcase only LCI product.

FREE GOLD CIRCLE PROGRAMS

STEP AND CHASSIS CARE DEALER PROFIT PROGRAM

LCI Part #	Description	Qty.	Dealer Price	Program
674806	Chassis Shield - Rust Inhibitor (Per can)	12		
379177	Kwik Lube - Spray Lubricant (12 cans per case)	1		
379600	Kwik Lube Glow in the Dark Step Tread - 6" x 21"	6		
704759	Step and Chassis Care Counter Display Box	1	FREE	FREE
Total:				

RV AIR FRESHENER DEALER PROFIT PROGRAM NEW



Air Fresheners

ADD SOME FRAGRANCE TO YOUR JOURNEY.

New! Hit the open road with a fresh, clean scent from Lippert Components. Choose from Vanilla Mist, Home Sweet Home, or Woody Sage and Salt — and give your RV a fragrance upgrade today! Our new line of air fresheners are a fun, aromatic addition to any vehicle, and will help keep your trip smelling fresh mile after mile.

DISCOVER FRESHNESS

LCI air fresheners are available in two fun, RV-themed designs and three fresh fragrances.

- Home Sweet Home
- Vanilla Mist
- Woody Sage and Salt



Air Fresheners Display

FREE COUNTER TOP DISPLAY OPPORTUNITY!

Purchase the RV Air Freshener Dealer Profit Program and receive the counter top display for FREE!

Limited time offer - while supplies last. Limit one display per dealership. Minimum order to qualify. Free qualifying display is to be kept clean, visible to consumers in retail store, and showcase only LCI product.

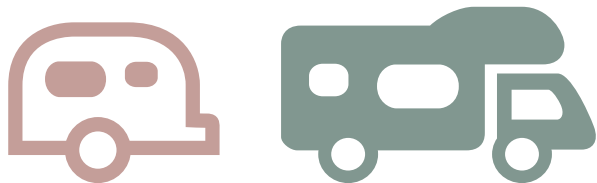

FREE GOLD CIRCLE PROGRAMS

AIR FRESHENER DEALER PROFIT PROGRAM

LCI Part #	Description	Qty.	Dealer Price	Program
808116	Home Sweet Home RV Air Freshener - Motorhome	18		
808117	Home Sweet Home RV Air Freshener - Travel Trailer	18		
808118	Woody Sage and Sea Salt RV Air Freshener - Motorhome	18		
808119	Woody Sage and Sea Salt RV Air Freshener - Travel Trailer	18		
808120	Vanilla Mist RV Air Freshener - Motorhome	18		
808121	Vanilla Mist RV Air Freshener - Travel Trailer	18		
811736	RV Air Freshener Profit Program Counter Display Box	1	FREE	FREE

Total:

360 SIPHON® RV VENT CAP DEALER PROFIT PROGRAM

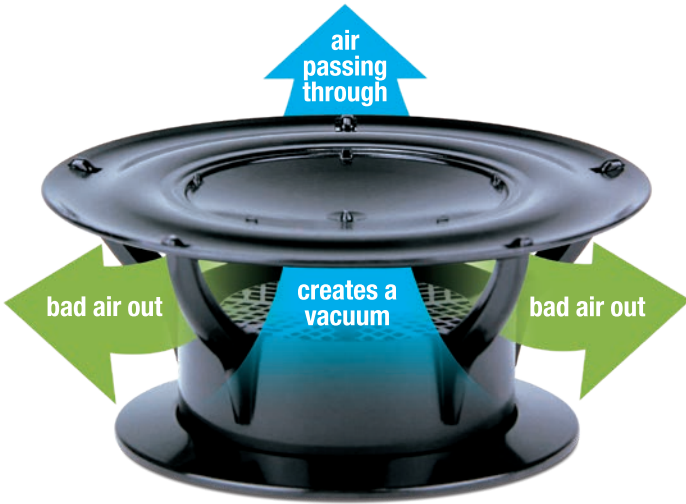

STOP THE STINK

The 360 Siphon® RV holding tank vent cap removes odors from the source — the holding tanks — and exhausts them out the roof vent before they have a chance to invade the RV living space. By design, the patented 360 Siphon® can only create an updraft, expelling odors and fostering an oxygen-rich environment to speed up waste breakdown.

FEATURES

- Prevents odors and gases from invading the RV living space
- Speeds up waste breakdown, eliminating the need for chemicals
- Sophisticated, patented design with no moving parts
- Works in any wind condition
- Made in America of strong polycarbonate
- Available in black or white
- Easy installation and universal fit
- Built-in bug screen
- No maintenance



FREE COUNTER TOP DISPLAY OPPORTUNITY!

Purchase 12 360 Siphon® products and receive the counter top display for FREE!

Limited time offer - while supplies last. Limit one display per dealership. Minimum order to qualify. Free qualifying display is to be kept clean, visible to consumers in retail store, and showcase only LCI product.

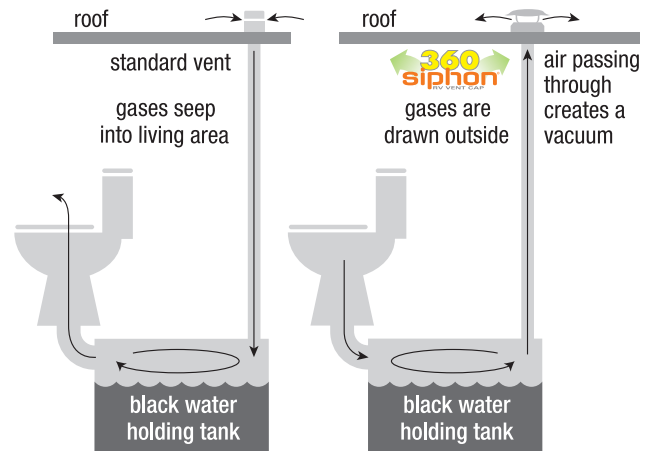

FREE GOLD CIRCLE PROGRAMS

360 SIPHON® RV VENT CAP DEALER PROFIT PROGRAM

LCI Part #	Description	Qty.	Dealer Price	Program
389380	360 Siphon Roof Vent (Gen II Black)	6		
389381	360 Siphon Roof Vent (Gen II White)	6		
768209	360 Siphon Profit Program Counter Display Box	1	FREE	FREE

Total:

SCREEN SHOT® DEALER PROFIT PROGRAM NEW



“CLOSE THE SCREEN DOOR!”

How many times have you heard this shouted while RVing? That’s because most RV screen doors DO NOT come with a retracting hinge. With our “junior” RVers constantly going inside and outside, this invites unwanted pests inside your living space.

The Screen Shot® by Lippert Components solves this issue. With its patent pending design, the Screen Shot closes your screen door* automatically, every time.

How does it work? The Screen Shot® is designed to install snugly into the inner channels of your screen door frame, held in place with anchor screws. The Screen Shot®’s elastic webbing is affixed directly into the door jamb, expanding when the door is opened and then pulls the door shut by itself.

FEATURES

- Patent pending design automatically closes the screen door when left opened
- Keeps unwanted pests out of your living space
- Easy DIY installation
- All required fasteners included
- *Fits ONLY Lippert Components entry doors; check the door’s identification sticker, typically located on the entry doors inside frame, before ordering (most LCI entry doors have an LCI decal in the bottom right-hand corner of the entry door window as well)
- Measure inside frame at threshold and round up to the nearest even number



Screen Shot Wallpaper

FREE WALLPAPER DISPLAY OPPORTUNITY!

Purchase the Screen Shot® Dealer Profit Program and receive the planogram wallpaper for FREE!

Limited time offer - while supplies last. Limit one display per dealership. Minimum order to qualify. Free qualifying display is to be kept clean, visible to consumers in retail store, and showcase only LCI product.



SCREEN SHOT® DEALER PROFIT PROGRAM

LCI Part #	Description	Qty.	Dealer Price	Program
730812	Screen Shot Assembly Kit, 24" Door Frame Width	2		
730813	Screen Shot Assembly Kit, 26" Door Frame Width	4		
730814	Screen Shot Assembly Kit, 28" Door Frame Width	2		
730815	Screen Shot Assembly Kit, 30" Door Frame Width	4		
768221	Screen Shot Vertical Profit Program Wallpaper	1	FREE	FREE

Total:

FREE GOLD CIRCLE PROGRAMS



Open to allow sunlight



Closed for privacy



Thin Shade Ready Kit

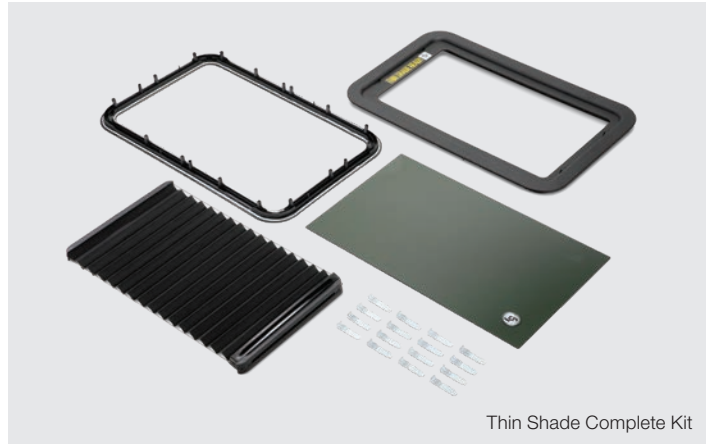

Thin Shade Complete Kit

BLOCK LIGHT AND HEAT, CREATE SHADE.

Are you one of the millions of RVers without an entry door shade solution? Prevent sunlight and heat from entering through your RV entry door window and add instant privacy to your home on wheels with the Thin Shade Complete Kit by Lippert Components. The Thin Shade Complete Kit is the first of its kind to offer an integrated blind into the entry door window frame. The Thin Shade Complete Kit contains a full window kit with everything needed for a DIY install: inside and outside frame, glass panel, attaching hardware, and Thin Shade blind.

FEATURES

- Easy, DIY upgrade for your RV entry door window
- Provides instant shade and privacy
- Conserve energy by blocking heat from the sun
- Thin Shade's pleated material easily adjusts up and down to let the right amount of sunlight in

SHADE AND PRIVACY NEVER LOOKED SO GOOD.

The revolutionary Thin Shade™ is a pleated window shade that's seamlessly integrated into your RV entry door window frame. Lippert Components has already prepped more than 100,000 RVs for the Thin Shade. The Thin Shade is a pleated window shade that's integrated inside the RV entry door window frame, creating a sleek, attractive look. The Thin Shade keeps the sun's rays out of your RV living space, helping to regulate the interior temperature and can create instant privacy.

FEATURES

- Provides instant shade and privacy
- Blocks the sun's rays from entering your RV interior space
- Integrated into the RV door window frame; other shades and reflectors need to be taken off and put back on when not in use
- Quick and easy installation only into Thin Shade Prepped RV entry doors by Lippert Components; no need to replace the entire RV entry door window
- Not compatible with non-prepped RV doors or non-LCI RV entry doors



Thin Shade Packaging

FREE GOLD CIRCLE PROGRAMS

THIN SHADE DEALER PROFIT PROGRAM

LCI Part #	Description	Qty.	Dealer Price	Program
786037	Thin Shade Integrated Window Shade (for Prepped Units)	2		
806621	Thin Shade Complete Entry Door Window Kit	4		
			Total:	

WE MAKE IT EASY. YOU MAKE THE SALE.

Lippert Components provides you with must-have products and all the necessary materials to create one-of-a-kind product planograms and displays. When you purchase a qualifying assortment of specific product lines, we provide you with print collateral that will be sure to push the product from the display to the register.



Flow Max™ Faucet Display



Solera® Universal Club Display



Screen Shot® Planogram

Limited time offer - while supplies last. Limit one display per dealership. Free qualifying display is to be kept clean, visible to consumers in retail store, and showcase only LCI product.

ONE-OF-A-KIND DISPLAYS.

Looking for a unique way to display your product to customers? Look no further. We provide you with the newest, cost-effective and space saving ways to beautifully display product our on your showroom floor.



Tongue Jack Display



Trailair Pin Box Display



Jack-IT Product Display

Limited time offer - while supplies last. Limit one display per dealership. Free qualifying display is to be kept clean, visible to consumers in retail store, and showcase only LCI product.

SMALL FOOTPRINT. BIG SALES.

These unique upright spider banners are easy to setup, move around, take up minimal floor space and give your customers the low down on the products you carry. Place one of the Ground Control banners in your service waiting area to let your customers know you have leveling upgrades or place a Thomas Payne Furniture banner at the entrance of your showroom to let customers know you offer furniture.



Ground Control Spider Banner

Solera Slide Topper Spider Banner

Thomas Payne Spider Banner

Limited time offer - while supplies last. Limit one display per dealership. Free qualifying display is to be kept clean, visible to consumers in retail store, and showcase only LCI product.

GET ONE MORE SALE.

Our counter displays work to make one last sale at the register. An extra moment to sell a product as you ring up a customer can create an impulsive up-sell opportunity. Our counter displays store the product in a presentable and easily accessible way so your customers get what they need right at the counter.



Sway Command Counter Display



Chassis Shield and KwikLube Can Counter Display



360 Siphon Counter Display

Limited time offer - while supplies last. Limit one display per dealership. Free qualifying display is to be kept clean, visible to consumers in retail store, and showcase only LCI product.

NOT YOUR TYPICAL BROWN BOX.

Our in-house design team creates LCI branded packaging that presents our products in eye-catching, shelf-ready boxes that will attract your customers.



IN-STORE MARKETING

Limited time offer - while supplies last. Limit one display per dealership. Free qualifying display is to be kept clean, visible to consumers in retail store, and showcase only LCI product.

EYE-CATCHING PRODUCT PACKAGING.

LCI branded packaging lets your customers know what product they are going to invest their hard earned money on. Our product packaging clearly lists the features, benefits, and quick hitting facts all while looking great.



Limited time offer - while supplies last. Limit one display per dealership.
Free qualifying display is to be kept clean, visible to consumers in retail store, and showcase only LCI product.