

## [ **ICONIC** & TECHNICAL ]

We are often asked how ICON develops such revolutionary performance suspension systems. The answer might surprise you. Our engineers actually start by determining a desired outcome of the vehicle they are working on. By studying forces and their effect on the vehicle in motion (Vehicle Dynamics) they are able to determine what improvements can be made. They determine how they can improve drivability of the vehicle, how to improve the handling characteristics and what changes can be made to improve the vehicle in real world situations. The end result of all this study is the highest quality and performing suspension products in the world. What also sets ICON products apart is our incredible commitment of time and energy dedicated to both ride development and testing. From vehicle dynamic theory to our years of experience and involvement in off road racing, rock crawling and just about anything you can do with a vehicle on or off the road. Our engineers are in control and the driving force of our entire product line and manufacturing processes. This is made possible because all of our laser cutting, metal forming, CNC machining, welding and assembly is done in house. Every product sold by ICON is made in the USA.



[ OMEGA SERIES SHOCK ]



# FORD F250 SUPERDUTY [2008-2010]



## OVERVIEW 7" SUSPENSION SYSTEM

ICON's 7" Suspension System for the 2008 Ford Super Duty's gives these trucks unparalleled performance and ride quality while allowing clearance for 38" tall tires. This system comes complete with ICON Series Mono-tube Shocks, Dual Rate Coil-Springs, Drop Pitman Arm, Pan Rod Bracket, Brake Line Brackets, Radius Arm Drop Down Brackets, ICON's Fabricated 6" Blocks and U-bolts (not pictured). All these components are covered by ICON's Life-time Warranty. [ PART # 6-7008 ]



## OVERVIEW 4.5" SUSPENSION SYSTEM

This 4.5" System for the 2008 Super Duty's is one the best riding suspension systems ICON has ever developed. This system has been engineered using the highest quality materials and components. The front Dual-Rate coils-springs combined with our ICON Series Mono-tube shocks give these trucks the performance they so desperately need. This system comes complete with front coils, shocks, radius arm drop down brackets, rear blocks and u-bolts and our patented Adjustable Track bar giving the front end of these trucks perfect track alignment. [ PART # 6-4550 ]

## OVERVIEW 2.5" LEVELING SYSTEM

This 2.5" Leveling System is a great way to level your 4WD 2008 F-350 Super Duty front to rear. The system's components provide for better-than-stock ride quality and is perfect for the cost-conscious truck owner who wants a level truck and a smooth ride.

For F-250 applications, a 4" block can be used in place of your factory 2" block, in turn leveling the truck from front to rear and allowing use of ICON Series Mono-tube Rear Shocks [ PART #6-2500 ]



## OVERVIEW 4.5-6.5" COIL-OVER CONVERSION KIT

This 4.5" - 6.5" Coil-over Conversion gives you the performance and ride quality you are looking for with having to lift your Super Duty 7". The coil-over shocks in this system can be adjusted from 4.5" of lift to 6.5" of lift. The Dual Rate coil-spring on these shocks are designed for a plush street ride as well as excellent performance offroad. This system comes complete with Upper and Lower coil-over Mounts, 4 Link System with on truck adjustability for Caster alignment, Adjustable Pan Rod Bar for Centering the front Axle, Billet Aluminum Bump Stop Spacers, and Brake Line Brackets. In the Rear we include Fabricated Rear Lift Blocks, with Plated U-bolts and ICON Series Rear Reservoir Shocks.

7" - 9" LIFT COIL-OVER CONVERSION KIT ALSO AVAILABLE.

[ PART #6-3002 ]

# [ ACCESSORIES & COMPONENTS ]



## 4-LINK SYSTEM

### OVERVIEW

This 4-Link System not only gives your truck an aggressive look, it enhances the articulation of the front suspension and improves handling of the truck by eliminating the large radius arm bushing and replacing it with competition grade spherical bearings in each link. This harder surface minimizes deflection to increase the over all handling characteristics of the truck. The lower links in the system include ICON's patented pinch bolt housing which allows for on truck adjustability.

[ PART # 6-1500 ]



## ADJUST-ABLE PAN ROD BAR

### OVERVIEW

This Adjustable Pan Rod Bar for the 2005 - Current Model Super Duties will realign your front end track alignment within factory specifications. It can be used on lifts from 2.5" up to 9". This bar can easily be installed using factory hardware and can be adjusted right on the truck without having to take it off. This Bar comes complete with polyurethane bushings to help minimize deflection and prevent the axle from moving left to right.

\*\*\*Any Lift over 6" will require the use of a Drop Down Bracket for the Pan Rod Bar.\*\*\*

[ PART #6-4030 ]



## CARRIER BEARING DROP

### OVERVIEW

This Carrier Bearing Kit is customizable for each truck it is installed on. Some trucks may need more drop to their carrier bearing than others, this is why this kit contains a collection of 1/4", 1/8", & 3/16" Shims. These shims make it simple to fine tune the drop and minimize driveline vibration.

[ PART # 3-37 ]



## TEI RELOCATION BRACKET KIT

### OVERVIEW

The TEI Relocation Bracket Kit will allow anyone with our systems to gain "The Extra Inch" that they are looking for. This simple bracket installs underneath the front coil-springs and adds 1" of ride height without changing the ride quality or performance of any our suspension systems. Whether its to clear larger tires or just for that extra boost in confidence, the TEI Relocation Bracket will do the trick.

[ PART #6-1600 ]



## BRAIDED BRAKELINE KIT 6-8" LIFT

### OVERVIEW

These stainless steel brake lines are ideal for replacing your factory rubber lines. These braided lines have a higher pressure rating and have minimal deflection ensuring precise braking pressures.

[ PART #6-1200 ]

## STEERING STABILIZER KIT WITH SHOCKS

### OVERVIEW

This Dual Steering Stabilizer System minimizes bump steer and smooths out the roughest of terrain felt through the steering wheel. This system bolts to the factory differential cover and wraps around the axle for a secure fit with out cutting welding or drilling.

The ICON Series Monotube Steering Stabilizer Shocks are specifically valved to minimize bump steer. [ PART #6-5000 ] [ SHOCKS PART #3-7504 (2) ]



**2.5" SHOCKS AVAILABLE  
SEE PG. 29 FOR DETAILS**

# FORD F250 SUPERDUTY [2005-2007]



## OVERVIEW 7" SUSPENSION SYSTEM

ICON's 7" Suspension System for the 2005 - 2007 Ford Super Duty's gives these trucks unparalleled performance and ride quality while allowing clearance for 38" tall tires. This system comes complete with ICON Series Mono-tube Shocks, Dual Rate Coil-Springs, Drop Pitman Arm, Pan Rod Bracket, Brake Line Brackets, Radius Arm Drop Down Brackets, ICON's Fabricated 6" Blocks and U-bolts (not pictured). All these components are covered by ICON's Life-time Warranty.

[ PART # 6-7000 ]



## OVERVIEW 4.5" SUSPENSION SYSTEM

This 4.5" System for the 2005 - 2007 Super Duty's is one the best riding suspension systems ICON has ever developed. This system has been engineered using the highest quality materials and components. The front Dual-Rate coils-springs combined with our ICON Series Mono-tube shocks give these trucks the performance they so desperately need. This system comes complete with front coils, shocks, radius arm drop down brackets, rear blocks and u-bolts and our patented Adjustable Track bar giving the front end of these trucks perfect track alignment.

[ PART # 6-4500 ]

## OVERVIEW 2.5" LEVELING SYSTEM

This 2.5" Leveling System is a great way to level your 4WD 2008 F-350 Super Duty front to rear. The system's components provide for better-than-stock ride quality and is perfect for the cost-conscious truck owner who wants a level truck and a smooth ride.

For F-250 applications, a 4" block can be used in place of your factory 2" block, in turn leveling the truck from front to rear and allowing use of ICON Series Mono-tube Rear Shocks. [ PART #6-2500 ]



## OVERVIEW 7-9" COIL-OVER CONVERSION KIT

This 7" - 9" Lift Coil-over Conversion gives you the performance and ride quality you are looking for while giving your Super Duty a great stance. The coil-over shocks in this system can be adjusted from 7" of lift to 9" of lift. The Dual Rate coil-spring on these shocks are designed for a plush street ride as well as excellent performance off road. This system comes complete with Upper and Lower coil-over Mounts, 4 Link System with on truck adjustability for Caster alignment, the 7"-9" Box kit which has the, Billet Aluminum Bump Stop Spacers, and Brake Line Brackets (brake lines are an option in this kit and are Highly Recommended), along with a new Pan Rod Bracket and Drop Pitman Arm. In the Rear we include our Progressive Rated 5" Leaf Springs, with Plated U-bolts and ICON Series Rear Reservoir Shocks.

4.5-6" LIFT COIL-OVER CONVERSION KIT ALSO AVAILABLE.

[ PART #6-3013 ]



# [ ACCESSORIES & COMPONENTS ]



## 4-LINK SYSTEM

### OVERVIEW

This 4-Link System not only gives your truck an aggressive look, it enhances the articulation of the front suspension and improves handling of the truck by eliminating the large radius arm bushing and replacing it with competition grade spherical bearings in each link. This harder surface minimizes deflection to increase the over all handling characteristics of the truck. The lower links in the system include ICON's patented pinch bolt housing which allows for on truck adjustability.

[ PART # 6-1500 ]



## ADJUST-ABLE PAN ROD BAR

### OVERVIEW

This Adjustable Pan Rod Bar for the 2005 - Current Model Super Duties will realign your front end track alignment within factory specifications. It can be used on lifts from 2.5" up to 9". This bar can easily be installed using factory hardware and can be adjusted right on the truck without having to take it off. This Bar comes complete with polyurethane bushings to help minimize deflection and prevent the axle from moving left to right.

\*\*\*Any Lift over 6" will require the use of a Drop Down Bracket for the Pan Rod Bar.\*\*\*

[ PART #6-4030 ]



## CARRIER BEARING DROP

### OVERVIEW

This Carrier Bearing Kit is customizable for each truck it is installed on. Some trucks may need more drop to their carrier bearing than others, this is why this kit contains a collection of 1/4", 1/8", & 3/16" Shims. These shims make it simple to fine tune the drop and minimize driveline vibration.

[ PART # 3-37 ]



## TEI RELOCATION BRACKET KIT

### OVERVIEW

The TEI Relocation Bracket Kit will allow anyone with our systems to gain "The Extra Inch" that they are looking for. This simple bracket installs underneath the front coil-springs and adds 1" of ride height without changing the ride quality or performance of any our suspension systems. Whether its to clear larger tires or just for that extra boost in confidence, the TEI Relocation Bracket will do the trick.

[ PART #6-1600 ]



## BRAIDED BRAKELINE KIT 6-8" LIFT

### OVERVIEW

These stainless steel brake lines are ideal for replacing your factory rubber lines. These braided lines have a higher pressure rating and have minimal deflection ensuring precise braking pressures.

[ PART #6-1200 ]

## STEERING STABILIZER KIT WITH SHOCKS

### OVERVIEW

This Dual Steering Stabilizer System minimizes bump steer and smooths out the roughest of terrain felt through the steering wheel. This system bolts to the factory differential cover and wraps around the axle for a secure fit with out cutting welding or drilling.

The ICON Series Monotube Steering Stabilizer Shocks are specifically valved to minimize bump steer. [ PART #6-5000 ] [ SHOCKS PART #3-7504 (2) ]



**2.5" SHOCKS AVAILABLE  
SEE PG. 29 FOR DETAILS**

# FORD F250 SUPERDUTY [1999-2004]



**OVERVIEW**

## 3" HANGER SYSTEM

The 3" system is designed to level out a Super Duty front to rear and to provide room for 305/70R16 tires. This system drops your stock springs 3", which allows for 3" of lift while maintaining the stock spring rate. With the stock spring rate & Icon custom valved shocks, you gain a plush, better-than stock ride that also corners well.

[ PART # 3-3000-99 ]



**OVERVIEW**

## 4" SPRING SYSTEM

ICON's 4" system provides great off-road performance, using the same technology that is used on off-road race trucks, and allows clearance for 35" tall tires. We start with ICON Series Progressive Rate Leaf Springs that have a lifetime guarantee against sagging. Next, we add the box kit which helps retain factory steering geometry. To get the best ride quality and performance, we add the ICON Series Mono-tube shocks that are custom valved for the truck. All of the components in the system are backed by the ICON Life-time Warranty.

[ PART # 3-4500-99 ]

**OVERVIEW**

## 4.5" HANGER SYSTEM

Our 4.5" Hanger System increases the ride height of your truck while maintaining a better than stock ride quality using the stock springs. All of our brackets and other suspension components bolt on to your truck without requiring any cutting, welding, or drilling. Installing this system with our ICON Series Mono-tube or Reservoir shocks will guarantee the best overall ride quality and performance. All of these components come backed by ICON's Life-Time Warranty

[ PART #3-4000-99 ]



**OVERVIEW**

## 6" SUSPENSION SYSTEM

ICON's 6" Suspension System uses ICON's Progressive Rate Front Leaf Springs for unparalleled performance and ride quality, while using a 6" block in the rear to maintain your truck's towing capacity. This system is great for the daily driver or for the avid off-roader. All in all this system will give you the best of both worlds

[ PART #3-6000-99 ]



**OVERVIEW**

### 8" SUSPENSION SYSTEM

ICON's 8" Suspension System isolates the use of ICON's Progressive Rated Leaf Spring packs to replace the rigid thick factory leaf pack. This system will increase the ride height of your Super Duty in order to clear 38" Tall tires. As with all of our systems we recommend accompanying them with the ICON Mono-tube or Remote Reservoir shocks for the best performance and ride quality. [ PART # 3-8000-99 ]

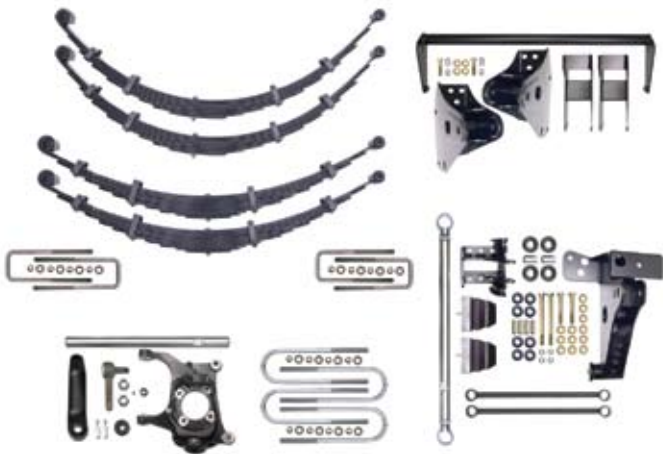

### 10.5" SPRING SYSTEM

**OVERVIEW**

To clear big tires with out severe body work and cutting you need a large amount of lift. This 10.5" System not only gives you clearance to run a 40" tall tire, but it rides like ICON's 6" system! Instead of using a huge thick leaf springs with a large amount of arc, this system uses ICON's progressive rated 6" front springs with a 4.5" hanger system to give you lift you want with the performance and ride quality you need. This system comes complete with a cross-over steering kit and large box kit with an adjustable track bar to give you optimum steering geometry so this truck steers like its stock! [ PART # 3-1000-99 ]

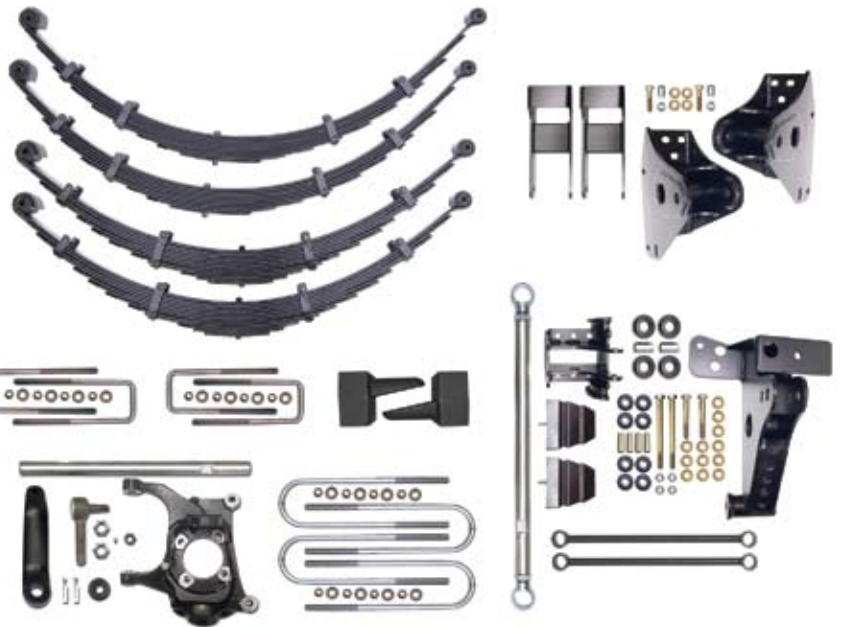

### 12.5" SPRING SYSTEM

**OVERVIEW**

To clear big tires with out severe body work and cutting you need a large amount of lift. This 12.5" System not only gives you clearance to run a 42" tall tire, but it rides like ICON's 8" system! Instead of using a huge thick leaf springs with a large amount of arc, this system uses ICON's progressive rated 8" front springs with a 4.5" hanger system to give you lift you want with the performance and ride quality you need. This system comes complete with a cross-over steering kit and large box kit with an adjustable track bar to give you optimum steering geometry so this truck steers like its stock!

[ PART #3-1200-99 ]



# FORD EXCURSION [2000-2005]



**OVERVIEW**

## 3" HANGER SYSTEM

This 3" system is designed to lift the Excursion 3" in front to provide room for 305/70R16 tires. This system drops your stock springs 3", which allows for 3" of lift while maintaining the stock spring rate. This system comes with a 1" bump stop spacer (not pictured) to prevent spring fatigue during the suspension cycle.

[ PART # 4-3000-99 ]



## 4.5" HANGER SYSTEM

**OVERVIEW**

Our 4.5" Hanger System increases the ride height of your truck while maintaining a better than stock ride quality and still utilizing the stock springs. All of our brackets and other suspension components bolt on to your truck without requiring any cutting, welding, or drilling. Installing this system with our ICON Series Mono-tube or Reservoir shocks will guarantee the best overall ride quality and performance. All of these components come backed by ICON's Life-Time Warranty.

[ PART # 4-4000-99 ]

**OVERVIEW**

## 5" SUSPENSION SYSTEM

Our 5" Suspension System for the 2000-2005 Excursion, isolates the use of our front and rear progressive rated springs. This system gives clearance of 35" tall tires and combined with the use of our ICON series Mono-tube or Reservoir Shocks, this system will give you best ride quality on and off-road.

[ PART #4-5000-99 ]



**OVERVIEW**

## 7" SUSPENSION SYSTEM

Our 7" Suspension System for the 2000-2005 Excursion offers you incredible performance and lift height. This system utilizes our plush riding progressive rate leaf springs in both the front and the rear. This system gives clearance of 37" tall tires and combined with the use of ICON series Mono-tube or Reservoir Shocks, this system will give you best ride quality on and off-road.

[ PART #4-7000-99 ]





# [ FORD F-150 ] [ 2004-2010 ]

## OVERVIEW 2WD & 4WD COIL-OVER SHOCK KIT

Designed with the serious driver in mind, this system allows for a 0-3" lift; and comes with a race inspired 2.5" shock body and internal reservoir, allowing for superior cooling and shock dampening. The system also includes an ICON designed Eibach coil spring and is completely pre-assembled. It works great on and off the road increasing performance and ride quality.

2004-2008 4WD [ PART # 9-1000 ]    2004-2008 2WD [ PART # 9-1500 ]  
2009-CURRENT 4WD [ PART # 9-1700 ]    2009-CURRENT 2WD [ PART # 9-1600 ]  
COIL-OVERS AVAILABLE WITH SEVERE WEATHER PLATING (IVD)

## OVERVIEW 2WD & 4WD MONO-TUBE SHOCK KIT

Icon Mono-Tube Shocks have an internal reservoir that allows for excellent cooling and optimum wheel travel. These custom valved shocks compliment our front coil-overs to the give the vehicle an unparalleled ride quality and unmatched performance on and off the road.

[ PART # 9-7500 2004 - 2008 4WD 2009 - CURRENT 2WD & 4WD ]  
[ PART # 9-7510 2004 - 2008 2WD ]





# GM SILVERADO [2003-2010]



GM SHOCK KIT APPLICATIONS INCLUDED FOR CHEVY SILVERADO 1500, GMC SIERRA 1500, CHEVY TAHOE, GMC YUKON, CHEVY SILVERADO HD, GMC HD

## OVERVIEW FRONT COIL-OVER SHOCK KIT

These coil-overs are valved specifically for the new body style (GMT 900 Platform) Chevrolet and GMC half ton, 2WD & 4WD applications. They not only drastically improve the off road characteristics of the vehicle, but increase the on road handling and performance as well.

[ PART # 7-1000 TAHOE / YUKON ] [ PART # 7-1005 TAHOE / YUKON EXTENDED TRAVEL ] [ PART # 7-1500 SILVERADO / SIERRA ] [ PART # 7-1505 SILVERADO / SIERRA EXTENDED TRAVEL ] COIL-OVERS AVAILABLE WITH SEVERE WEATHER PLATING (IVD)



## OVERVIEW MONO-TUBE SHOCKS

These ICON Series Monotube Shocks are Sold Individually. They are specifically valved to give the 2007-Up GMT900 Platform Trucks and SUV's for the best possible ride quality and performance.

[ PART # 7-7500 ]



# DODGE RAM 1500 [2009-2010]

## PERFORMANCE SUSPENSION SYSTEM

Dodge owners, now you can have your cake and it eat it too. With the complete ICON performance suspension system for the 2009 – current Dodge Ram 1500 you get incredible performance, ride quality and it will level out your vehicle. The system includes our tried and true 2.5" adjustable coil-overs that are valved specifically for the vehicle and include an OE style mounting fork, rear replacement variable rate coil-springs that offer more payload capacity and a better ride, and our race style 2.5" rear piggy-back shocks that compliment the front coil-overs with internal valving specifically for the vehicle.



[ PART # 21-1500 ]





# DODGE RAM 2500/3500 [2003-2010]

## OVERVIEW 2.5" 4WD SUSPENSION SYSTEM

The ICON 2.5" Dodge 2500 / 3500 suspension system levels out your truck and offers you both incredible ride quality and performance. The system includes our 2.5" variable rate front coil springs, replacement urethane bump stops, adjustable pan-rod bar to re-align your front track alignment, sway bar link extensions for additional down travel without binding and your choice of front 2.5" smooth body shocks or 2.5" remote reservoir shocks and either 2.5" smooth body or 2.5" piggy-back shocks in the rear.

[ PART # 21-2500 ]



## OVERVIEW 4" 4WD SUSPENSION SYSTEM

If 2.5" of lift is not enough for you, Icon offers our 4" performance suspension system. Once again you will experience unparalleled ride quality and performance. This system includes everything our 2.5" system has but comes with our variable rate 4" front coil-springs for smooth on road and unsurpassed off road performance.

[ PART # 21-4000 ]

## HIGH STEER SYSTEM

OVERVIEW

The ICON high steer system converts the factory "Y" steering to a one piece drag-link and a one piece tie-rod for improved steering geometry, consistent wheel alignment and helps reduce steering deflection.

[ PART #21-4050 ]



## CONTROL ARM SYSTEM

OVERVIEW

The ICON control arm is the ultimate add-on to either our 2.5" or 4" suspension systems. The lower links are made of 2" thick walled tubing and 1 3/4" on the uppers and offer improved caster and better front end alignment. The lower links are adjustable on the vehicle to improve handling and steering characteristics. The offset link design optimizes clearance for larger tires.

[ PART #21-4040 ]



## REAR LEAF EXPANSION PACK

OVERVIEW

How do you add lift height and performance to the rear spring without losing load or towing capacity? By adding the ICON rear leaf expansion pack. The expansion pack keeps the factory main and overload leaves and replaces the leaves in between. The pack offers a softer spring rate than stock for improved ride quality and performance but does not change load or towing capacities.

[ PART #21-1100 ]



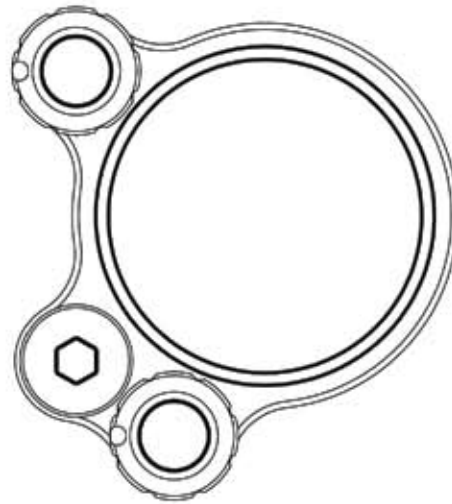

RADIAL FLOW TECHNOLOGY

6061 AIRCRAFT GRADE ALUMINUM COMPONENTS

NITROGEN CHARGED PIGGYBACK OR REMOTE RESERVOIR



INCREMENTAL DENTED TUNING

2.5" DIAMETER SHOCK BODY  
(3.5" DIAMETER SHOCK BODY IN DEVELOPMENT)

DYNAMIC HEAT TRANSFER SYSTEM

HIGH RESOLUTION ADJUSTABILITY



# MEGA

E R I E S



[ INFINITE TUBE CONFIGURATIONS ]



[ AVAILABLE IN 9", 10", 12", 14", 16", 18" ]



[ MANY OPTIONS AVAILABLE ]



NITRO STEEL SHAFT

TEFLON LINED SPHERICAL BEARINGS

# JEEP JK [2007-2010]



## OVERVIEW 4" SUSPENSION SYSTEM

ICON Vehicle Dynamics spent over a year in development for this system. It has been designed and manufactured to achieve the best overall ride quality and performance. This 4" Suspension System won the Peterson 4 Wheel and Off-road, JK Shoot Out competition in 2007, and was named the Best OVERALL JK Suspension System.

[ PART # 2-4000 ]

## [ ACCESSORIES & COMPONENTS ]

### FRONT ADJUSTABLE TRACK BAR

#### OVERVIEW

This Adjustable Track Bar for the 2007-Current JK will work on any Lifted JK. This Pan Rod Bar will realign your front end after a lift has been installed. The bar contains Polyurethane Bushings on one end that has minimal deflection, and a rod end with our patented pinch bolt housing that allows on truck adjustability.

[ PART #2-1020 ]



### REAR ADJUSTABLE TRACK BAR

#### OVERVIEW

This Adjustable Track Bar for the 2007-Current JK will work on any Lifted JK. This Pan Rod Bar will realign your rear end after a lift has been installed. The bar contains Polyurethane Bushings on one end that has minimal deflection, and a rod end with our patented pinch bolt housing that allows on truck adjustability.

[ PART #2-1025 ]



### FRONT UPPER LINK KIT

#### OVERVIEW

These Upper Links for the Front of a JK are made out of stout quarter inch wall tubing and is easily adjusted to length using our patented machined pinch housing. These links are a great addition to our standard JK System and allows for even more front end alignment possibilities.

[ PART #2-1035 ]





**NISSAN**  
TITAN/FRONTIER/XTERRA  
PATHFINDER  
**[2004-2010]**



**OVERVIEW**

**TITAN SUSPENSION SYSTEM - STAGE 1**

This is our complete performance suspension system for the 2004-Current Titan. This system works great in both on and off-road scenarios. Our front coil-over shocks are tuned specifically to give your Titan a great ride quality on and off the road. The ICON Series Rear Mono-tube shocks in the system are tuned to match the front coil-over shocks in every aspect and will be incredible upgrade compared to the factory rear shocks. Recommended tire size 305/70R17, wheel 17X8 with 5 1/4" back spacing.

[ PART # 8-3001 4WD, 8-3010 2WD ] COIL-OVERS AVAILABLE WITH SEVERE WEATHER PLATING (IVD)

**SUZUKI EQUATOR & NISSAN FRONTIER COIL-OVER SUSPENSION SYSTEM**

**OVERVIEW**

These adjustable coil-over shocks have proven their strength and longevity for years on end and they keep going. These shocks offer the best ride quality and handling. They increase suspension travel and dramatically increase the capabilities of your 2005-up Frontier OR Equator's front suspension. These coil-over's are valved for heavier front end applications. V6 Trucks, or trucks with an aftermarket heavy front bumper or light valving for 4 cylinder applications. Recommended tire size 275/65R16, wheel 16X8 with 5" back spacing.



[ PART # 8-2000 LIGHT VALVING 8-2005 LIGHT VALVING EXTENDED TRAVEL ]

[ PART # 8-2010 HEAVY VALVING 8-2015 LIGHT VALVING EXTENDED TRAVEL ] COIL-OVERS AVAILABLE WITH SEVERE WEATHER PLATING (IVD)



**OVERVIEW**

**PATHFINDER FRONT COIL-OVER SHOCK KIT**

Give your Pathfinder the look and feel it deserves by adding the ICON adjustable front coil-overs. These shocks offer the best ride quality and handling. They increase suspension travel and dramatically increase the capabilities of your 2005 - current Pathfinder's front suspension. These coilover's are valved for heavier front end applications. V6 Trucks, or light valving for trucks with a 4 cylinder . Recommended tire size 275/65R16, wheel 16X8 with 5" back spacing.

[ PART # 8-2000 LIGHT VALVING 8-2005 LIGHT VALVING EXTENDED TRAVEL ] [ PART # 8-2010 HEAVY VALVING 8-2015 LIGHT VALVING EXTENDED TRAVEL ] COIL-OVERS AVAILABLE WITH SEVERE WEATHER PLATING (IVD)

**XTERRA FRONT COIL OVER SHOCK KIT**

**OVERVIEW**

You purchased an Xterra to go off the beaten path and explore new worlds. Now your suspension can keep up with you. The tried and true Icon adjustable front coil-overs offer incredible ride quality and performance. They will increase wheel travel and allow for fitment of a larger tire. These coilover's are valved for heavier front end applications. V6 Trucks, or light valving for trucks with a 4 cylinder . Recommended tire size 275/65R16, wheel 16X8 with 5" back spacing.

[ PART # 8-2000 LIGHT VALVING 8-2005 LIGHT VALVING EXTENDED TRAVEL ] [ PART # 8-2010 HEAVY VALVING 8-2015 LIGHT VALVING EXTENDED TRAVEL ] AVAILABLE WITH SEVERE WEATHER PLATING (IVD)





# TOYOTA TACOMA [2005-2010]



## REMOTE RESERVOIR FRONT COIL-OVER SHOCK KIT

OVERVIEW

These shocks were in development for over a year. ICON Vehicle Dynamics has taken their already perfect performing coil-over shocks and given it the dissipation and long lasting performance of a full blown race shock. All of this has been developed to bolt on and install with ease. They increase suspension travel and dramatically increase the capabilities of your 05-Current Tacoma's front suspension. These coil-over's come complete with all the hardware necessary to complete the installation as well as a sway bar relocation bracket kit to adjust the location of the sway bar to clear the larger shock and reservoir mounting brackets. Recommended tire size 285/75R16, wheel 16X8 with 5" back spacing. [ PART # 5-8730 EXTENDED TRAVEL # 5-8735 ]

COIL-OVERS AVAILABLE WITH SEVERE WEATHER PLATING (IVD)



OVERVIEW

## FRONT COIL-OVER SHOCK KIT

These adjustable coil-over shocks have proven their strength and longevity for years. From the California deserts to the mud swamps of Florida they are tried and true. These shocks offer the best ride quality and handling. They increase suspension travel and dramatically increase the capabilities of your 05-Current Tacoma's front suspension. These coil-over's come complete with all the hardware necessary to complete the installation as well as a sway bar relocation bracket kit to adjust the location of the sway bar to clear the larger shock. Recommended tire size 285/75R16, wheel 16X8 with 5" back spacing.

[ PART # 5-8630 EXTENDED TRAVEL # 5-8635 ] COIL-OVERS AVAILABLE WITH SEVERE WEATHER PLATING (IVD)



OVERVIEW

## REAR ADD A LEAF KIT

This 3 Leaf Progressive Add a Leaf Kit comes complete with U-bolts and Center pins for an easy install. This add a leaf kit will give your Tacoma 1.5" of lift after installation. Just remove the factory overload and say good bye to that rough factory ride.

[ PART # 5-1100 ]

## BILLET UPPER CONTROL ARM KIT

OVERVIEW

ICON Vehicle Dynamics prides themselves in the highest quality components available. These Billet Aluminum Upper Control Arms are a great addition to any aftermarket coil-over shock system. They eliminate the weak factory upper ball joint with a Teflon lined 1" uniball for added strength and durability, not to mention extra articulation. They are also adjustable for Caster and Camber to fine tune your truck alignment whether it is lifted or not. They also feature a Uniball Dust Cover to protect the Uniball from debris preventing premature wear. Using all 17-4 Heat Treated Stainless, these uniball and taper components will surely outlast your truck.

[ PART # 5-8550 ]



**OVERVIEW**

## REAR RESERVOIR SHOCKS

The ICON Series Rear Reservoir Shocks for the 05 and up Tacoma's will enhance the ride of any suspension, whether it be stock or lifted. These shocks increase wheel travel and provide excellent control over many different types of terrain, be it asphalt, rocks or whooped out desert terrain. These shocks come complete with a reservoir mount to mount on the outside of the frame to ensure proper cooling and to keep the reservoir out of harms way.

[ PART # 5-7505x2 ]



**TOYOTA**  
**TACOMA**  
**[1996-2004]**

**OVERVIEW**

## FRONT COIL-OVER SHOCK KIT

These adjustable coil-over shocks have proven their strength and longevity for years on end and they keep going. These shocks offer the best ride quality and handling on the market. They increase suspension travel and dramatically increase the capabilities of your 96-04 Tacoma's front suspension. These coil-over's are offered in both standard and extended travel to be installed with an aftermarket uniball upper control arm kit to ensure the proper amount of wheel travel and to prevent premature ball joint wear. Recommended tire size 285/75R16, wheel 16X8 with 4.5" back spacing

[PART # 5-8610, EXTENDED TRAVEL # 5-8615 ] COILOVERS AVAILABLE WITH SEVERE WEATHER PLATING (IVD)



**OVERVIEW**

## REAR RESERVOIR SHOCKS

The ICON Series Rear Reservoir Shocks for the 96-04 Tacoma's will enhance the ride of any suspension, whether it be stock or lifted. These shocks increase wheel travel and provide excellent control over many different types of terrain, be it asphalt, rocks or whooped out desert terrain. These shocks come complete with reservoir clamps to ensure proper positioning and to keep the reservoir out of harms way.

[ PART # 5-7506&07 ]

**OVERVIEW**

## REAR ADD A LEAF KIT

This 3 Leaf Progressive Add a Leaf Kit comes complete with U-bolts and Center pins for an easy install. This add a leaf kit will give your Tacoma 1.5" of lift after installation. Just remove the factory overload and say good bye to that rough factory ride.

[ PART # 5-1100 ]



# TOYOTA TUNDRA [2007-CURRENT]



## OVERVIEW FRONT COIL-OVER SHOCK KIT

These adjustable coil-over shocks have proven their strength and longevity for years on end and they keep going. These shocks offer the best ride quality and handling. These shocks add 2" of additional wheel travel and dramatically increase the capabilities of your 07-08 Tundra's front suspension. These coil-over's come complete with all the hardware necessary to complete the installation. Recommended tire size 305/60R18, wheel 18X9 with 5" back spacing. [PART #5-8650]

AVAILABLE WITH SEVERE WEATHER COATING (IVD). EXTENDED LENGTH APPLICATIONS AVAILABLE. ALSO AVAILABLE WITH EXTERNAL RESERVOIRS.

## OVERVIEW REAR EXPANSION PACK

The 3 leaf rear expansion pack for the 2007 - current Tundra offers additional lift height, ride quality and performance. You replace the leaves between the factory main and over-load leaves. This allows for a better than stock spring rate which cycles easier and keeps the stock load carrying capacity. [PART # 5-1200]



## OVERVIEW REAR MONO-TUBE SHOCKS

ICON's Monotube series shocks are great for any purpose. On or off-road these shocks will give you the best performance and ride quality. They are also backed by ICON's Life-time Warranty. These are the last shocks you will ever have to buy for your '07-up Tundra. [PART # 5-7520]

## OVERVIEW 2.5" DIAMETER MONO-TUBE REAR SHOCK / STOCK TO 3" LIFT

These 2.5" Diameter Smooth Body Shocks are a great way to add more performance and incredible ride quality to your rear suspension. These shocks are specifically valved to give the '07 to Current Tundra improved ride and handling characteristics and are fine are tuned for better performance than our standard 2.0 Mono-tube Shocks. [PART # 5-7620]



## OVERVIEW 2.5" DIAMETER PIGGYBACK MANIFOLD RESERVOIR REAR SHOCK

Our 2.5" Diameter Piggyback Manifold Shocks are the ultimate performance shock. They offer the same incredible valving as our 2.5" mono-tube shocks but, will dissipate heat better and have more down travel. These shocks also have a built in bump zone. [PART # 5-7720]





**OVERVIEW**

## BILLET ALUMINUM UPPER CONTROL ARM SYSTEM

We are proud to announce the release of the Billet Aluminum Upper Control Arm System for the 2007 - Current Toyota Tundra's. These control arms will enhance the handling and articulation of the Tundra's Suspension. They are constructed of 6061 Aluminum and C.N.C. Machined for precise suspension geometry. The Teflon Lined Uniball Bearings installed in the arms articulate much better than the stock ball joint and are much more durable. Unlike most aftermarket arms that utilize polyurethane bushings, we use Teflon Lined Rod Ends for smoother, quieter operation that insures minimal deflection for accurate and stable handling.



[ PART # 5-8560 ]



**OVERVIEW**

## FRONT COIL-OVER SHOCK KIT

These adjustable coil-over shocks have proven their strength and longevity for years on end and they keep going. These shocks offer the best ride quality and handling. They increase suspension travel and dramatically increase the capabilities of your Tundra's front suspension. These coil-over's come complete with all the hardware necessary to complete the installation. These are a Race-Proven shock designed for the daily driver and the avid offroader all in one! Recommended tire size 285/75R16, wheel 16X8 with 4.5" back spacing.

AVAILABLE WITH SEVERE WEATHER COATING (IVD). EXTENDED LENGTH APPLICATIONS AVAILABLE. ALSO AVAILABLE WITH EXTERNAL RESERVOIRS. [ PART #5-8620 EXTENDED TRAVEL # 5-8625]

**OVERVIEW**

## REAR ADD A LEAF KIT

This 3 Leaf Progressive Add a Leaf Kit comes complete with U-bolts and Center pins for an easy install. This add a leaf kit will give your Tundra 1.5" of lift after installation. Just remove the factory overload and say good bye to that rough factory ride.

[ PART # 5-1100 ]



**OVERVIEW**

## REAR MONO-TUBE SHOCKS

ICON's Monotube series shocks are great for any purpose. On or off-road these shocks will give you the best performance and ride quality. They are also backed by ICON's Life-time Warranty. These are the last shocks you will ever have to buy for your Tundra.

[ PART # 5-7515 ]

# TOYOTA FJ CRUISER [2007-2010]



# TOYOTA 4RUNNER [2003-2009]

## REMOTE RESERVOIR FRONT COIL-OVER SHOCK KIT

OVERVIEW

These shocks were in development for over a year. ICON Vehicle Dynamics has taken their already perfect performing coil-over shocks and given it the dissipation and long lasting performance of a full blown race shock. All of this has been developed to bolt on and install with ease. They increase suspension travel and dramatically increase the capabilities of your FJ Cruiser or 4Runner's front suspension. These coil-over's come complete with all the hardware necessary to complete the installation as well as a sway bar relocation bracket kit to adjust the location of the sway bar to clear the larger shock and reservoir mounting brackets. Recommended tire size 285/75R16, wheel 16X8 with 5" back spacing.

[ PART # 5-8730, EXTENDED TRAVEL #5-8735]  
AVAILABLE WITH SEVERE WEATHER COATING (IVD).



OVERVIEW

## FRONT COIL-OVER SHOCK KIT

These adjustable coil-over shocks have proven their strength and longevity for years on end and they keep going. These shocks offer the best ride quality and handling. They increase suspension travel and dramatically increase the capabilities of your FJ Cruiser's front suspension. These coil-over's come complete with all the hardware necessary to complete the installation as well as a sway bar relocation bracket kit to adjust the location of the sway bar to clear the larger shock. Recommended tire size 285/75R16, wheel 16X8 with 5" back spacing.

[ PART # 5-8630, EXTENDED TRAVEL # 5-8635] AVAILABLE WITH SEVERE WEATHER COATING (IVD).

OVERVIEW

## 2" LIFT REAR COIL SPRINGS

These 2" Lift Coil-springs improve your on and offroad ride quality. The slightly higher spring helps with load bearing capacity while increasing ride height to clear larger tires. When used in conjunction with ICON's Rear Monotube or 2.5" Piggy-Back shocks the ride quality and performance is unbeatable. These springs are also guaranteed for LIFE not to sag.

[ PART # 5-2700 ]

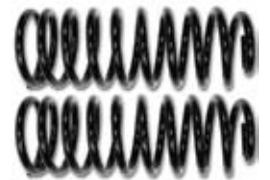

**OVERVIEW**

### BILLET ALUMINUM UPPER CONTROL ARM KIT

ICON Vehicle Dynamics prides themselves in the highest quality components available. These Billet Aluminum Upper Control Arms are a great addition to any aftermarket coil-over shock system. They eliminate the weak factory upper ball joint with a teflon lined 1" uniball for added strength and durability, not to mention extra articulation. They are also adjustable for Caster and Camber to fine tune your truck alignment whether it is lifted or not. They also feature a Uniball Dust Cover to protect the Uniball from debris preventing premature wear. Using all 17-4 Heat Treated Stainless, these uniball and taper components will surely outlast your truck.

[ PART # 5-8550 ]



**OVERVIEW**

### REAR MONO-TUBE SHOCKS

ICON's Monotube series shocks are great for any purpose. On or off-road these shocks will give you the best performance and ride quality. They are also backed by ICON's Life-time Warranty. These are the last shocks you will ever have to buy for your FJ Cruiser.

[ PART # 5-7510 ]

**OVERVIEW**

### REAR 2.5" DIAMETER PIGGY BACK RESERVOIR SHOCKS

These 2.5" Diameter Shocks for the rear of the FJ Cruiser will give the avid offroader the performance and ride quality they are looking for. These shocks are tuned and valved specifically for the best on and off road performance.

They are constructed of the same high quality components used in the all of ICON's coil-over shocks. The PiggyBack Reservoir gives the shock added heat dissipation and its locations gives the shock an internal bump zone. This bump zone gives added control and stability when the suspension is pushed to full compression

[ PART # 5-7710 ]



**OVERVIEW**

### BILLET ALUMINUM REAR TRAILING ARM KIT

These Billet Aluminum Rear Trailing Arms for the Toyota FJ Cruiser are a great replacement for weak Factory Lower Links. These trailing arms are light and strong. They include 16T Rod Ends that have a load rating of over 40,000lbs of pressure and a replaceable nylon skid. These rear trailing arms will outlast the truck. They also includes a rebuildable Johnny Joint on the axle side for excellent articulations and minimal deflection.

[ PART # 5-4000 ]

**OVERVIEW**

### BILLET ALUMINUM UPPER LINK ARM KIT

These Billet Aluminum Upper Link Arms for the FJ Cruiser are a great replacement for weak Factory Upper Links. These links are light and strong. They include a 3/4" Rod End that have a load rating of over 20,000lbs of pressure. These links use a greaseable polyurethane bushings for a smooth ride with minimal deflection.

[ PART # 5-4100 ]



**OVERVIEW**

### REAR ADJUSTABLE TRACK BAR

This Adjustable Track bar for the FJ Cruiser is the best way to optimize your 4 Wheel Handling and Wheel Alignment. When your track alignment is off center it can cause premature tire wear and limit articulation. This bar is an easy to install and can easily be adjusted on the truck without having to take it on and off. It is the perfect accessory for a lifted FJ.

[ PART # 5-4200 ]



# TOYOTA LANDCRUISER [2008-2010]



**OVERVIEW**

## FRONT COIL-OVER SHOCK KIT

How do you improve one of the greatest vehicles ever built? With ICON 2.5" adjustable coil-overs that's how. These shocks add 2" of additional wheel travel and dramatically increase the capabilities of your 08-10 Landcruiser's front suspension. These coil-over's come complete with all the hardware necessary to complete the installation. Recommended tire size 305/60R18, wheel 18X9 with 5" back spacing.

[ PART #5-8660 ]

AVAILABLE WITH SEVERE WEATHER COATING (IVD). EXTENDED LENGTH APPLICATIONS AVAILABLE. ALSO AVAILABLE WITH EXTERNAL RESERVOIRS.

**OVERVIEW**

## BILLET ALUMINUM REAR TRAILING ARM KIT

These Billet Aluminum Rear Trailing Arms for the 08-up Land Cruiser are a great replacement for weak Factory Lower Links. These trailing arms are light and strong. They include 16T Rod Ends that have a load rating of over 40,000lbs of pressure and a replaceable nylon skid. These rear trailing arms will outlast the truck. They also includes a rebuildable Johnny Joint on the axle side for excellent articulations and minimal deflection.



[ PART # 5-4000 ]



**OVERVIEW**

## FRONT COIL-OVER SHOCK KIT

These adjustable coil-over shocks have proven their strength and longevity for years on end and they keep going. These shocks offer the best ride quality and handling. They increase suspension travel and dramatically increase the capabilities of your 4Runner's front suspension. These coil-over's come complete with all the hardware necessary to complete the installation. These are a Race-Proven shock designed for the daily driver and the avid offroader all in one! Recommended tire size 285/75R16, wheel 16X8 with 4.5" back spacing.

[ PART #5-8610, EXTENDED TRAVEL # 5-8615 ] AVAILABLE WITH SEVERE WEATHER COATING (IVD)

# 4RUNNER [1996-2002]

# SEQUOIA [2000-2010]

## FRONT COIL-OVER SHOCK KIT

Who said Sequoia's are only for soccer mom's? They are a very capable off road vehicle. Built on the Tundra chassis they can easily go where ever you may want to go and with style. By adding ICON coil-overs you will have increased suspension travel and dramatically increase the capabilities of your Sequoia's front suspension. These coil-over's come complete with all the hardware necessary to complete the installation. These are a Race-Proven shock designed for the daily driver and the avid offroader all in one! Recommended tire size 285/75R16, wheel 16X8 with 4.5" back spacing.

[ PART # 5-8620 EXTENDED TRAVEL #5-8625 2001 - 2007 MODELS 5-8650 2008 - CURRENT ]

AVAILABLE WITH SEVERE WEATHER COATING (IVD)



# TOYOTA TUNDRA [2007-2010]

## [ LIFTED APPLICATIONS ]

### OVERVIEW 6" - 7" LIFT ADJUSTABLE COIL-OVER SHOCK

These coil-over shocks will bolt on to any 2007- Current Tundra that has a ProComp 6" Lift Kit installed on to it. These shocks replace the supplied top load spacer/factory shock combination with a 2.5" Diameter Fine Tuned Race Style Coil-over. These shocks are built specifically around the ProComp Drop Down brackets and will increase performance, enhance ride quality and improve handling all at the same time to your lifted Tundra.

[ PART # 5-8651 ]



### TUNDRA [2000-2006]

### OVERVIEW 6" - 7" LIFT ADJUSTABLE COILOVER SHOCK

These coil-over shocks will bolt on to any 2000-2006 Tundra, 2WD or 4WD that has an RCD 6" Lift Kit installed on to it. These shocks replace the supplied Bilstein non-adjustable shocks with a 2.5" Diameter Fine Tuned Race Style Coil-over. These shocks are built specifically around the RCD Drop Down brackets and will increase performance, enhance ride quality and improve handling all at the same time to your lifted Tundra.

[ PART # 5-8626 ]



### TACOMA [2005-2010]

### 6" - 7" LIFT ADJUSTABLE COILOVER SHOCK

These coil-over shocks will bolt on to any 2005-Current Tacoma that has a ProComp 6" Lift Kit installed on to it. These shocks replace the supplied top load spacer/factory shock combination with a 2.5" Diameter Fine Tuned Race Style Coil-over. These shocks are built specifically around the ProComp Drop Down brackets and will increase performance, enhance ride quality and improve handling all at the same time to your lifted Tacoma.

[ PART # 5-8631 ]



### FJ CRUISER [2005-2010]

### 6" - 7" LIFT ADJUSTABLE COILOVER SHOCK

Have you installed a Rough Country 6" lift kit and realized that you sacrificed ride quality and performance for lift height? ICON has the answer for you. Our 2.5" adjustable coil-overs were designed from the ground up specifically for the 2007- Current FJ Cruiser that has a Rough Country 6" Lift Kit installed on to it. These shocks replace the supplied top load spacer/factory shock combination with a 2.5" Diameter Fine Tuned Race Style Coil-over. These shocks are built specifically around the RC Drop Down brackets and will increase performance, enhance ride quality and improve handling all at the same time to your lifted FJ.

[ PART # 5-8641 ]

### FORD F150 [2004-2008]

### OVERVIEW 6" - 7" LIFT ADJUSTABLE COILOVER SHOCK

These 2.5" ICON adjustable coil-overs were designed to add performance, ride quality and some additional lift height to the Fabtech lift kit. Valved specifically for the truck with this kit installed the shocks eliminate the top load spacer and offer our tried and true on and off road performance. Note: we are currently testing coil-overs for various other F150 sub-frame kits. Please contact us for more information.

[ PART # 9-1501 ]



# [ 2" MONO-TUBE SHOCKS ]

## OVERVIEW

ICON's Monotube series shocks are great for any purpose. On or off-road these shocks will give you the best performance and ride quality. They are also backed by ICON's Life-time Warranty. These are the last shocks you will ever have to buy for your vehicle.

**AVAILABLE IN THREE (3) CONFIGURATIONS**



[ EYE TO EYE ]

[ STEM TOP ]

[ RESERVOIR ]



# [ 2.5" SHOCKS ]

## OVERVIEW

ICON V.S. Series 2.5" Diameter Smooth Body and Piggy-Back Shocks are Vehicle Specific shocks that are valved and sized for optimal performance with ICON Vehicle Dynamics suspension systems. Bred from the same high quality components as our coil-over shock line, these shocks are the perfect upgrade. The ICON V.S. Series shocks are competitively priced with other non vehicle specific brands and do not require re-valving. We offer many custom options & applications for our V.S. Series 2.5" shocks.



[ SMOOTH BODY ]



[ STEM TOP W/EXTERNAL RESERVOIR ]



[ EYE-TO-EYE W/EXTERNAL RESERVOIR ]

# [ APPAREL & ACCESSORIES ]

DECALS. HATS. T-SHIRTS. JACKET. VEHICLE ACCESSORIES. IPOD CASE. T-SHIRTS. JACKETS. SWEATERS. V

DECALS. HATS. T-SHIRTS. JACKETS. SWEATERS. VEHICLE ACCESSORIES. IPOD CASES. DECALS. HATS. T-SHI

## T-SHIRTS



### BASIC TEE

This is our basic design T-shirt. These shirts are printed on premium JS Apparel Tee's with waterbased ink for a soft broken in feel. Wash after wash they will get softer and the logos will blend to a vintage look. It comes in sizes from Medium to XXL.



### LOGO SPLATTER

This is our Splattered Logo shirt. These shirts are printed on premium JS Apparel Tee's with waterbased ink for a soft broken in feel. Wash after wash they will get softer and the logos will blend to a vintage look. It comes in sizes from Medium to XXL.



### LOGO CROWD

This is our Crowded Logo Shirt. These shirts are printed on premium JS Apparel Tee's with waterbased ink for a soft broken in feel. Wash after wash they will get softer and the logos will blend to a vintage look. It comes in sizes from Medium to XXL.



### WING TEE

This is our ICONIC Wings shirt. These shirts are printed on premium JS Apparel Tee's with waterbased ink for a soft broken in feel. Wash after wash they will get softer and the logos will blend to a vintage look. It comes in sizes from Medium to XXL.

## DECALS



## JACKETS

### ICON DICKIES JACKET

This is an Eisenhower Dickies Jacket with the ICON Logo on the front left breast and the back center. Please choose your jacket size below.



## HATS

### ICON FLEXFIT HATS

These are Flexfit Brand Premium Hats Embroidered with the IVD Shield on the front and the word "ICON" on the back. They are extremely comfortable and come in two sizes and two colors.



WEATERS. VEHICLE ACCESSORIES. IPOD CASES. DECALS. HATS. T-SHIRTS. JACKETS. SWEATERS. VEHICLE A  
ES. DECALS. HATS. T-SHIRTS. JACKETS. SWEATERS. VEHICLE ACCESSORIES. IPOD CASES. DECALS. HATS. T-S  
ICLE ACCESSORIES. IPOD CASES. DECALS. HATS. T-SHIRTS. JACKETS. SWEATERS. VEHICLE ACCESSORIES. I  
RTS. JACKETS. SWEATERS. VEHICLE ACCESSORIES. IPOD CASES. DECALS. HATS. T-SHIRTS. JACKETS. SWEA

## **BILLET ALUMINUM IPOD CASE** IPOD VIDEO/NANO/ ITOUCH

The ICON SHIELD™ Billet Aluminum iPod® case uses a patented slide and lock system. This allows you easy access to your iPod® any time you need it. No tools necessary. As far as strength and durability go, the ICON SHIELD™ is machined from 6061-T6 aluminum. Available options include car mounts, UTV mounts, off-road vehicle mounts and boat mounts. This gives you the freedom to take your iPod® anywhere you go, while knowing it will be protected.



## **SHIFT KNOB** **BILLET SHIFT KNOB & TRANSFER CASE KNOB** TOYOTA FJ CRUISER/TUNDRA/4RUNNER

This shift knob is machined from 6061 Aluminum. It comes with everything you need to replace your factory shift knob and can be installed in seconds. The shift knob comes complete the shift indicator and an adhesive round. [ PART # 5-4550 ]

## **STAINLESS STEEL LOWER SHOCK SHIN GUARD** TOYOTA FJ CRUISER

This Rear Lower Shock Shin Guard is made out of 304 Stainless Steel. This guard prevents your rear shocks from dragging on rocks and other obstacles while on your offroad adventures. The "Shin Guard" design helps prevent debris from prematurely wearing your shock's shaft which will prolong the shocks life. Stainless Steel was our first choice for this piece because it is exposed to the elements and road debris more than any other part of the rear suspension. The hardened stainless will prevent corrosion and will not gouge like common steel skids.

[ PART # 5-6100 ]



## **REAR LOWER LINK GUARD** TOYOTA FJ CRUISER

These rear lower link guards are made out of 304 stainless steel and help prevent damage to the stock lower link brackets. The stock lower link brackets are extremely easy to bend and are commonly damaged by rocks and debris. The hardened stainless steel will prevent corrosion and will not gouge like common steel guards.

