

BORGESON

Steering You Forward



INTRODUCTION

Founded in Torrington, CT, Borgeson Universal began manufacturing universal joints for lathes and milling machines in 1914. By the 1920's, Ford was using Borgeson universal joints for the steering on some of their prototypes. Borgeson Universal continued to develop and refine u-joints for industrial, aerospace and OEM vehicle applications. When purchased in 1982 by the current owners, two avid Street Rodders, Borgeson soon began developing applications for Street Rods. Borgeson has continually improved and developed the original needle bearing universal joints into the most reliable, smoothest operating, strongest u-joints available today.

Seeking to expand, Borgeson ventured into manual steering gears with the acquisitions of Mullins Steering Gears in 2001 and in July 2012 Borgeson acquired all of the original equipment, tooling, drawings and the OE manufacturing rights for all Saginaw manual steering gear boxes. In 2016 Borgeson relocated from its home of over 100 years in Torrington CT and expanded yet again into a new 101,000 square foot manufacturing facility in Travelers Rest SC. This 101,000 square foot plant was designed and built for increased production and capacity to better serve our customers. We use the latest manufacturing and inventory control procedures to maintain stock, and take great pride in being able to ship most orders placed by 2:30 EST the same day. Today, Borgeson is the leading manufacturer and supplier of aftermarket steering components for the street rod, racing, specialty automotive, OEM and pickup truck markets.

We believe our growth is based on a policy of honesty and always listening to our customers, whether you are a corporation or working in your garage. We respond to your suggestions by developing needed innovations to help increase steering system safety and make building your vehicle more fun. Our dedication to safety has been recognized by the National Street Rod Association with safety product of the year awards in 1992 & 2001 as well as Street Rod Manufacturer Of The Year in 1999. Ultimately, your vehicle's safety depends on you. We strive to make Borgeson steering components as safe as possible. You can't buy a stronger, safer u-joint anywhere in the world! However, its effectiveness is only as good as the installation.

In this catalog, you will find many installation suggestions and guidelines that will help in the design of a safe, smooth operating steering system. Call if you have any questions. Our technical staff has over 95 years combined experience in the design and application of steering systems. Remember, auto manufacturers have thousands of engineers and millions of miles of road experience to rely on when designing a steering system. Without the benefit of those resources, the possibility of a malfunction is greater. So, overbuild your system and inspect it frequently. Safety should be your most important concern! We attend many shows during the year, so stop by our booth and say hello, we'll be happy to help!

A message from Borgeson president Gerry Zordan,

Over 100 years ago, John Borgeson built a wooden universal joint model, dated July 22nd, 1914, for application to the United States Patent Office. This is the oldest Borgeson universal joint that we are aware of. His goal was to provide high quality products at a fair price. 100 years later, that very same universal joint graces my office as a tribute to, and reminder of, where it all began.

For the last 35 years, since I purchased Borgeson, we have been dedicated to the same philosophies of creating the best quality products at fair prices while providing outstanding customer service. This continued business model has helped us to grow from a humble four part-time employees all those years ago, to 35 full-time employees, proudly dedicated to providing high quality products and outstanding customer service.

This growth and longevity is, in no small part, attributed to you, our valued customers. I thank you for the continued support and loyal patronage that has helped Borgeson Universal to become the great American company that it is today.

*Thank you, Gerry Zordan,
President, Borgeson Universal Co. Inc.*

Borgeson President Gerry Zordan



Borgeson Vice President Alan Zordan



CONTENTS

STREET ROD

UNIVERSAL JOINTS & SHAFTS

STEERING COLUMNS & MOUNTS

SAGINAW MANUAL STEERING BOXES



MUSCLE CAR

POWER STEERING CONVERSIONS

P/S PUMPS, BRACKETS & PULLEYS

SAGINAW MANUAL STEERING BOXES



TRUCK & SUV

HEAVY DUTY STEERING SHAFTS

POWER STEERING UPGRADES



SINGLE U-JOINTS.....	3
DOUBLE U-JOINTS.....	4
VIBRATION REDUCERS & RAG JOINTS.....	5
INTERMEDIATE STEERING SHAFTS.....	6
TELESCOPING SHAFTS.....	6
SUPPORT BEARINGS.....	7
COUPLERS & ADAPTERS.....	7
PIN & BLOCK RACING U-JOINTS.....	8
STEERING COLUMNS & MOUNTS.....	9
NEW 49-51 FORD CARS.....	10
SAGINAW MANUAL STEERING BOXES.....	11-12
PITMAN ARMS.....	11
MUSCLE CAR STEERING.....	12
PUMPS, BRACKETS & PULLEYS.....	13-14
1962-79 MOPAR.....	14
1963-72 CHEVY II.....	15
1958-64 CHEVY CAR.....	15
1955-57 CHEVY CAR.....	16
1963-82 CORVETTE.....	17
1965-04 MUSTANG.....	18
1952-64 FORD FULL SIZE.....	19
1964-77 FORD MID SIZE.....	20
1966-04 FORD TRUCK & BRONCO.....	21
1972-06 JEEP.....	22
1979-08 DODGE TRUCK.....	23
1973-08 CHEVYIGMC TRUCK.....	24
NEW CUSTOM STEERING SHAFT KITS.....	24
STEERING SYSTEM DESIGN.....	25-29
POWER STEERING TIPS.....	30
STEERING TROUBLE SHOOTING.....	31
SPLINE REFERENCE CHART.....	32
SHOP TOUR.....	33
ORDERING & SHIPPING INFORMATION.....	34

SINGLE NEEDLE BEARING UNIVERSAL JOINTS

Needle Bearing U-Joints

Needle bearing u-joints have the distinct advantage of lasting much longer than non-needle bearing u-joints. Borgeson recommends only needle bearing u-joints for use on street vehicles. Our u-joints are made of specially selected steel and stainless steel for strength and longevity. The sealed precision needle bearings never need maintenance. Needle bearing u-joints outlast non-needle bearing joints by a factor of 10 to 1. Our needle bearing joints have zero backlash (radial play) for more precise steering and a better feel for the road. Although non-needle bearing joints are stronger than the same size needle bearing joint, this strength is offset by the maintenance required and the longevity factor. Non-needle bearing joints should be lubricated with each use and a rubber boot should be used to retain lubrication. Boots are not recommended for use with needle bearing joints.

Borgeson u-joints are machined in our factory on state of the art CNC equipment from solid billet steel or stainless steel. Ongoing engineering and testing ensures our components meet or exceed current automotive production vehicle requirements. Any of our four Double D (a round shaft with two flats) sizes, 14 different spline size yokes, and the '94 and later Mustang V style can be combined to mate components from many different manufacturers. They operate at angles up to 35°. For example, with our components, you could easily connect a GM column to a new Mustang rack and pinion or a Ford column to a Saginaw box. Similar to OEM u-joints, the staked needle bearing caps prevent loosening and adjustment malfunction.



Single Joint Dimensions

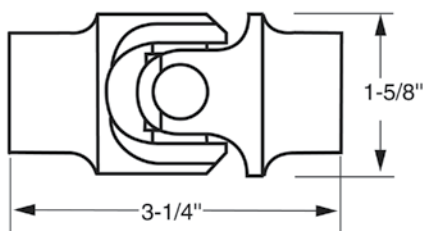

Stainless Steel



Polished Stainless Steel



SINGLE UNIVERSAL JOINT PRICES

Universal Joint Ends	Steel	Stainless Steel
Any Smooth X Smooth Combination	\$71.50	\$83.22
Any Spline or DD X Smooth Combination	\$75.61	\$87.91
Any Spline or DD X Spline or DD Comb.	\$79.71	\$92.60

SINGLE UNIVERSAL JOINT PART #'S

Steel	Stainless Steel	Polished Stainless	Description
Smooth X Smooth Bore			
016464	116464	126464	3/4" Smooth x 3/4" Smooth
Spline or DD X Smooth Bore			
010964	110964	120964	9/16"-26 Spline x 3/4" Smooth
011864	111864	121864	5/8"-36 Spline x 3/4" Smooth
013164	113164	123164	3/4"-30 Spline x 3/4" Smooth
013464	113464	123464	3/4"-36 Spline x 3/4" Smooth
014064	114064	124064	13/16"-36 Spline x 3/4" Smooth
012564	112564	122564	11/16"-36 Spline x 3/4" Smooth
014364	114364	124364	1"-48 Spline x 3/4" Smooth
014664	114664	124664	17 mm DD x 3/4" Smooth
014964	114964	124964	3/4" DD x 3/4" Smooth
015264	115264	125264	1" DD x 3/4" Smooth
015564	115564	125564	3/4" Ford V x 3/4" Smooth
Spline or DD x Spline or DD			
014334	114334	124334	1"-48 Spline x 3/4"-36 Spline
014349	114349	124349	1"-48 Spline x 3/4" DD
014352	114352	124352	1"-48 Spline x 1" DD
013409	113409	123409	3/4"-36 Spline x 9/16"-26 Spline
013418	113418	123418	3/4"-36 Spline x 5/8"-36 Spline
013425	113425	123425	3/4"-36 Spline x 11/16"-36 Spline
013431	113431	123431	3/4"-36 Spline x 3/4"-30 Spline
013434	113434	123434	3/4"-36 Spline x 3/4"-36 Spline
013440	113440	123440	3/4"-36 Spline x 13/16"-36 Spline
013446	113446	123446	3/4"-36 Spline x 17mm DD
013449	113449	123449	3/4"-36 Spline x 3/4" DD
013452	113452	123452	3/4"-36 Spline x 1" DD
013737	113737	123737	3/4"-48 Spline x 3/4"-48 Spline
014909	114909	124909	3/4" DD x 9/16"-26 Spline
014912	114912	124912	3/4" DD x 9/16"-36 Spline
014918	114918	124918	3/4" DD x 5/8"-36 Spline
014921	114921	124921	3/4" DD x 5/8"-36 Chrysler Spline
014925	114925	124925	3/4" DD x 11/16"-36 Spline
014928	114928	124928	3/4" DD x 11/16"-40 Spline
014930	114930	124930	3/4" DD x 3/4"-20 Spline
014931	114931	124931	3/4" DD x 3/4"-30 Spline
014937	114937	124937	3/4" DD x 3/4"-48 Spline
014940	114940	124940	3/4" DD x 13/16"-36 Spline
014946	114946	124946	3/4" DD x 17mm DD
014949	114949	124949	3/4" DD x 3/4" DD
014955	114955	124955	3/4" DD x 3/4" Ford V
014952	114952	124952	3/4" DD x 1" DD
015225	115225	125225	1" DD x 11/16"-36 Spline
015231	115231	125231	1" DD x 3/4"-30 Spline
015240	115240	125240	1" DD x 13/16"-36 Spline
015252	115252	125252	1" DD x 1" DD
015255	115255	125255	1" DD x 3/4" Ford V

DOUBLE NEEDLE BEARING UNIVERSAL JOINTS

Angles over 35° can be negotiated by using a Borgeson double universal joint. These double universal joints can accommodate angles up to 70°. Double universal joints are available in steel, stainless steel and polished stainless steel. Borgeson double universal joints are available in all of our popular spline and DD configurations.

TECH TIP: Because a double joint used in combination with a single joint will function the same as a three joint system, a shaft support bearing is required to prevent the shaft from "looping" and binding. See page 7 for shaft support bearings.



Polished Stainless Steel

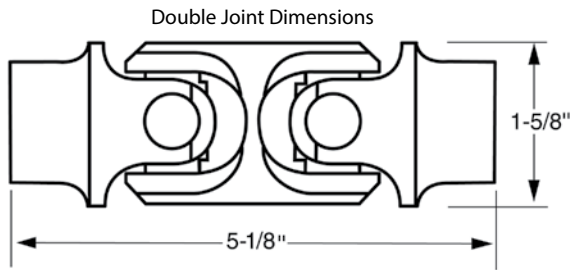

Double Joint Dimensions

DOUBLE UNIVERSAL JOINT PRICES

Universal Joint Ends

- Any Smooth X Smooth Combination
- Any Spline or DD X Smooth Combination
- Any Spline or DD X Spline or DD Comb.

DOUBLE UNIVERSAL JOINT PART #'S

Steel	Stainless Steel	Polished Stainless	Description
Smooth X Smooth Bore			
026464	136464	146464	3/4" Smooth x 3/4" Smooth
Spline or DD X Smooth Bore			
020964	130964	140964	9/16"-26 Spline x 3/4" Smooth
021864	131864	141864	5/8"-36 Spline x 3/4" Smooth
023164	133164	143164	3/4"-30 Spline x 3/4" Smooth
023464	133464	143464	3/4"-36 Spline x 3/4" Smooth
024064	134064	144064	13/16"-36 Spline x 3/4" Smooth
024364	134364	144364	1"-48 Spline x 3/4" Smooth
024664	134664	144664	17mm DD x 3/4" Smooth
024964	134964	144964	3/4" DD x 3/4" Smooth
025264	135264	145264	1" DD x 3/4" Smooth
Spline or DD X Spline or DD			
024334	134334	144334	1"-48 Spline x 3/4"-36 Spline
024349	134349	144349	1"-48 Spline x 3/4" DD
023409	133409	143409	3/4"-36 Spline x 9/16"-26 Spline
023418	133418	143418	3/4"-36 Spline x 5/8"-36 Spline
023431	133431	143431	3/4"-36 Spline x 3/4"-30 Spline
023434	133434	143434	3/4"-36 Spline x 3/4"-36 Spline
023449	133449	143449	3/4"-36 Spline x 3/4" DD
024949	134949	144949	3/4" DD x 3/4" DD
024946	134946	144946	3/4" DD x 17mm DD
024918	134918	144918	3/4" DD x 5/8"-36 Spline
024952	134952	144952	3/4" DD x 1" DD

POPULAR SPLINE SIZES

Nominal Size	Diameter	Splines in a Full Circle
9/16"-17 Spline	.562	17
9/16"-26 Spline	.562	26
9/16"-36 Spline	.562	36
5/8"-36 Spline GM*	.625	36
5/8"-36 Spline Chrysler	.625	36
11/16"-36 Spline	.687	36
11/16"-40 Spline	.687	40
3/4"-20 Spline	.745	20
3/4"-30 Spline	.730	30
3/4"-36 Spline	.735	36
3/4"-48 Spline	.750	48
13/16"-36 Spline	.812	36
1"-48 Spline	.985	48

Actual size can measure .015" over or under the size listed. *5/8"-36 GM and 5/8"-36 Chrysler are not interchangeable.

DOUBLE D (DD) SIZES

Nominal Size	Approx. Dia.	Approx. Size Across Flats
17mm DD	.670	.570
18mm DD	.730	.610
3/4" DD	.750	.550
1" DD	.993	.790
3/4" Ford V	.750	N/A

Different U-Joint Shaft Applications

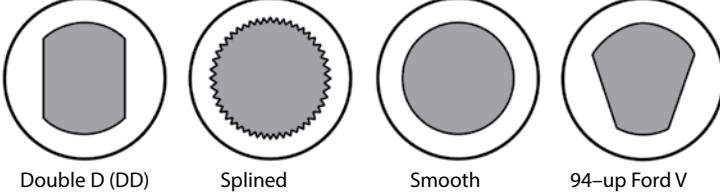

Double D (DD)

Splined

Smooth

94-up Ford V



Splined Shaft



3/4" Double D (DD) Solid



1" Double D (DD) Tubing



3/4" Ford-V

VIBRATION REDUCERS

Noise, vibration, and harshness are on top of the list of concerns for all automotive enthusiasts. With the more frequent use of rack and pinions and low profile tires, there are more road vibrations transmitted to the steering wheel than in the past. Using urethane to isolate all of the metal components, Borgeson has developed vibration reducers to diminish the annoying vibrations that are transmitted through the steering system and felt in the steering wheel. The use of the Borgeson vibration reducer results in an immediate improvement of the steering feel. As an added benefit, this reduction in vibration has been shown to increase the overall life of the steering components, including the steering column and box.

DESIGN AND INSTALLATION TIP:

Don't install a vibration reducer in the center of a length of shaft. It can cause excess flexing and possible binding. If your system requires the use of a support bearing, the vibration reducer must be used between the support bearing and the column. The support bearing can pick up chassis vibration and will transfer it up the steering shaft to the wheel reducing the effects of the vibration reducer.

Rubber Coupling/Rag Joints

On older factory applications, a flexible coupling was used to attach the column to the steering box when there was perfect alignment. If the original column or box is changed, the stock coupling may not work. If a conversion from a long input steering box to a short input with an aftermarket column is done, a flexible coupling needs to be added. Borgeson offers the largest variety of spline and double D sizes to fit most applications. Rag Joints are only available in steel.

RAG JOINT PRICING

All Complete Rag Joint Couplers

RAG JOINT PART #'S

Part#	Description	Part #	Description
052534	11/16"-36 Spline x 3/4"-36 Spline	053449	3/4"-36 Spline x 3/4" DD
052549	11/16"-36 Spline x 3/4" DD	053452	3/4"-36 Spline x 1" DD
052552	11/16"-36 Spline x 1" DD	054043	13/16"-36 Spline x 1"-48 Spline
053134	3/4"-30 Spline x 3/4"-36 Spline	054052	13/16"-36 Spline x 1" DD
053149	3/4"-30 Spline x 3/4" DD	054940	3/4" DD x 13/16"-36 Spline
053152	3/4"-30 Spline x 1" DD	055034	18mm DD x 3/4"-36 Spline
053434	3/4"-36 Spline x 3/4"-36 Spline	055043	18mm DD x 1"-48 Spline
053440	3/4"-36 Spline x 13/16"-36 Spline	055049	18mm DD x 3/4" DD
053443	3/4"-36 Spline x 1"-48 Spline	055052	18mm DD x 1" DD

Rag Joint



Rag Joint Dimensions

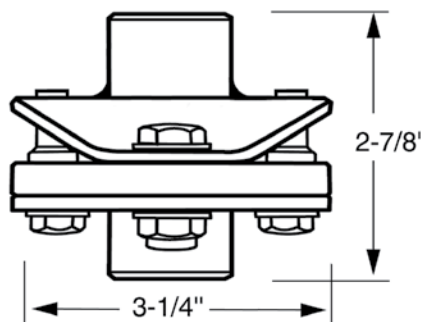

Polished Stainless Steel Vibration Reducing Universal Joint

Vibration Reducing Universal Joints

Vibration reducing universal joints or VJ's come with a 9/16"-26, 5/8"-36, 3/4"-30, 3/4"-36, or 3/4"-DD coupler end and any spline or DD size on the universal joint side. The VJ's are also available in stainless steel and polished stainless with the same sizes available.

VIBRATION JOINT PRICING

All Steel Vibration Reducing Universal Joints

All Stainless Steel Vibration Reducing Universal Joints

All Polished Stainless Steel Vibration Reducing Universal Joints

VIBRATION REDUCING UNIVERSAL JOINT PART #'S

Steel	Stainless Steel	Polished Stainless	Description
033434	153434	163434	3/4"-36 Spline x 3/4"-36 Spline
033449	153449	163449	3/4"-36 Spline x 3/4" DD
033452	153452	163452	3/4"-36 Spline x 1" DD
033443	153443	163443	3/4"-36 Spline x 1"-48 Spline
034943	154943	164943	3/4" DD x 1"-48 Spline
034909	154909	164909	3/4" DD x 9/16"-26 Spline
034931	154931	164931	3/4" DD x 3/4"-30 Spline
034934	154934	164934	3/4" DD x 3/4"-36 Spline
034949	154949	164949	3/4" DD x 3/4" DD
034952	154952	164952	3/4" DD x 1" DD
034940	154940	164940	3/4" DD x 13/16"-36 Spline

*Vibration reducers are not available with smooth bores. They should not be welded.

Vibration Reducing Universal Joint Dimensions

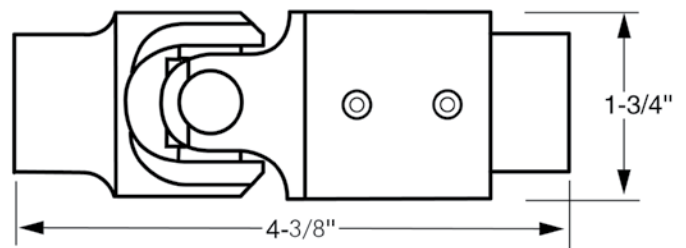

Splined and Double D Shafting

We recommend splined or double D shafting, as its a simple and safe method of attaching your steering components. We offer 3/4" double D shafts in steel and stainless steel. Splined shafts are available in steel, stainless steel and polished stainless steel.

Telescoping Shaft

Borgeson offers two telescoping shaft assemblies in 24" and 36" overall lengths. These shafts can be used in a variety of applications and make installation and removal of steering system components simple and easy. By pulling or pushing on the assembly, the overall length can be shortened or lengthened. This telescopic shaft also meets NHTSA guidelines for collapsibility in passenger cars and adds a measure of safety.

SAFETY TIP: Welding can overheat the u-joint bearings causing loss of lubrication. **If welding is the only option, it should be done by a certified welder.** Drilling and pinning can be a safer option. *See page 28 for more information on pinning and proper shaft attachment.*

See our design section beginning on page 23 for information about measuring your system.

STEERING SHAFT PRICING				
Steel	Price	Stainless Steel	Price	Polished Stainless
2" Splined	\$21.68	3"-16" Splined	\$43.96	3"-16" Splined
4"-16" Splined	\$35.16	16.25"-36" Splined	\$47.77	16.25"-36" Splined
18"-36" Splined	\$38.10	24"-36" Splined	\$47.77	24"-36" Splined
18" DD Shaft	\$25.00	22" DD Shaft	\$47.77	22" DD Shaft
36" DD Shaft	\$39.00	36" DD Shaft	\$64.47	36" DD Shaft

STEERING SHAFT PART #'S			
Steel	Stainless Steel	Polished Stainless	Description
Splined at Both Ends			
409202	N/A	N/A	3/4"-36 Spline x 2" Long
409204	419204	429204	3/4"-36 Spline x 4" Long
409206	419206	429206	3/4"-36 Spline x 6" Long
409208	419208	429208	3/4"-36 Spline x 8" Long
409210	419210	429210	3/4"-36 Spline x 10" Long
409212	419212	429212	3/4"-36 Spline x 12" Long
409214	419214	429214	3/4"-36 Spline x 14" Long
409216	419216	429216	3/4"-36 Spline x 16" Long
409218	419218	429218	3/4"-36 Spline x 18" Long
409220	419220	429220	3/4"-36 Spline x 20" Long
Splined at One End			
409005	N/A	N/A	3/4"-36 Spline x 5" Long
409016	N/A	N/A	3/4"-36 Spline x 16" Long
409036	N/A	N/A	3/4"-36 Spline x 36" Long
Double D (DD)			
409418	N/A	N/A	3/4" DD x 18" Long
409436	419436	429436	3/4" DD x 36" Long
N/A	419422	429422	3/4" DD x 22" Long
N/A	419412	429412	3/4" DD x 12" Long
Telescoping Shafting			
450024	N/A	N/A	24" Telescopes 21"-27"
450036	N/A	N/A	36" Telescopes 30"-39"

Steel 3/4" Splined Shafts are splined 2" on both ends. They are available in 2" increments from 2" to 36". Each end can be trimmed up to 1" for an exact fit. Steel 3/4" round shafts that are splined on one end are available in 5", 16", and 36" lengths.



Steel Double D Shafts are available in 18" and 36" lengths only. They are easy to trim to get an exact fit.



Stainless Steel 3/4" Splined Shafts are available in 1/4" increments from 3" to 24" lengths, with 7/8" of spline on each end. Custom length stainless shafting is also available with 7/8" spline on each end, polished or unpolished. (polished shown)



Stainless Steel Double D Shafts are available in 12", 22" and 36" lengths. All stainless shafting is available polished or unpolished. (polished shown)



Telescoping Shafts

Borgeson offers two telescoping shaft assemblies in 24" and 36" overall lengths. These shafts can be used in a variety of applications and make installation and removal of steering system components simple and easy. Telescopic shafts can be easily trimmed to fit many applications.



SHAFT SUPPORTS & COUPLERS

Steering Supports

If more than two joints are used in a steering system, a support bearing must be used to prevent looping and binding. Use of a vibration reducer and two u-joints will also call for a support bearing to be used. The support must be mounted to the frame, not to a sheet metal section of the body; sheet metal will not withstand the stress. The shaft should fit easily through the support with no binding. A system with a double u-joint and a single u-joint has three flex points and will require a support bearing.

All support bearings work with round or DD shafting.

Rod end bearings with a 3/4" hole size are commonly used for supports. Rod end bearings are supplied with two jam nuts for mounting. They are available in steel, stainless steel and polished stainless steel. Our billet supports accommodate a 3/4" shaft. The billet supports are 2-1/2" long with two threaded holes in the end for mounting and are available in steel, aluminum, polished aluminum, stainless steel, and polished stainless steel. A 6" steel support is also available, which can be cut at any angle for a perfect fit. The 6" steel support has no mounting holes and must be welded in. Flange bearings are also available for supporting a shaft through the firewall.

Couplers and Adapters

A u-joint can sometimes be eliminated by using a 2" straight extension, called a coupler, to extend either the steering box, R&P shaft or the column shaft. The coupler can be welded and/or pinned to the un-splined end of a shaft. We offer shafts that are splined only on one end in 3 lengths: 5", 16" and 36". The 1"-48 and 1" DD couplers have a 1-1/4" hole that will accept either an adapter to reduce inside diameter to 3/4" smooth or another splined or 3/4" DD coupler. The coupler assembly would have to be pinned and/or welded together. Welding the coupler is acceptable because there are no moving parts to damage, and the coupler's steel is less susceptible to heat damage from welding. Couplers are available in the same spline or double D sizes as our u-joints. Couplers and adapters are available in steel only.

ADAPTERS	
Part #	Description
358000	3/4 X 1 O.D. ADAPTER
358200	3/4 X 1-1/4 O.D. ADAPTER

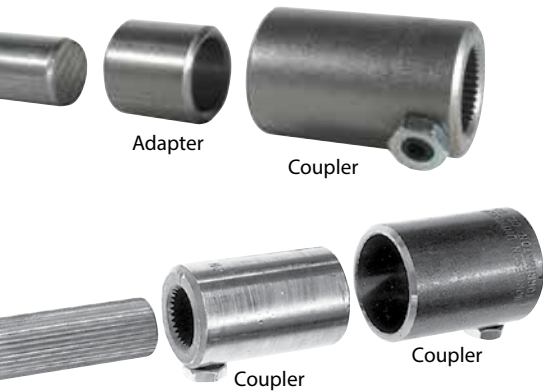

STEERING SUPPORTS

Part #	Description
650000	Billet Aluminum Support Bearing
660000	Polished Billet Aluminum Support Bearing
670000	Billet Steel Support Bearing
670600	6" Billet Steel Cut and Weld Support Bearing
680000	Billet Stainless Steel Support Bearing
690000	Polished Billet Stainless Steel Support Bearing
700000	Steel Rod End Bearing
710000	Stainless Steel Rod End Bearing
720000	Polished Stainless Steel Rod End Bearing
700010	Firewall Flange Bearing



COUPLERS

Part #	Description
310900	9/16"-26 Spline x 3/4" Smooth Bore
311800	5/8"-36 Spline x 3/4" Smooth Bore
312100	5/8"-36 Chrysler Spline x 3/4" Smooth Bore
312500	11/16"-36 Spline x 3/4" Smooth Bore
313400	3/4"-36 Spline x 3/4" Smooth Bore
313434	3/4"-36 Splined Through Coupler
315249	1" DD x 3/4" DD Welded Coupler Assembly
314000	13/16"-36 Spline x 1" Smooth Bore
314300	1"-48 Spline x 1-1/4" Smooth Bore
314349	1"-48 Spline x 3/4" DD Welded Coupler Assembly
314900	3/4" DD x 3/4" Smooth Bore
313449	3/4"-36 Spline x 3/4" DD Welded Coupler Assembly
315200	1" DD x 1-1/4" Smooth Bore

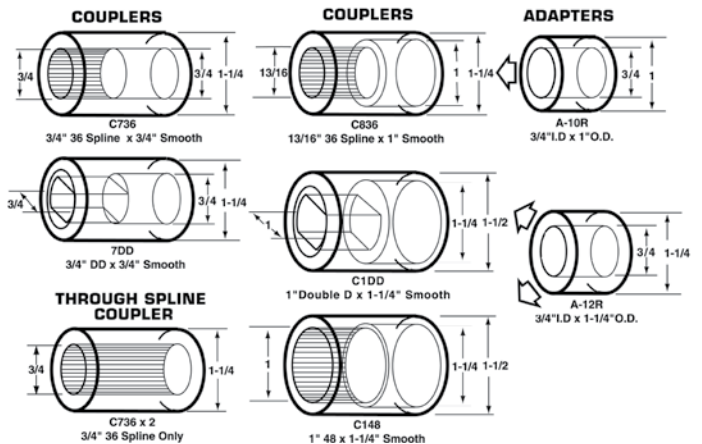

PIN & BLOCK RACING JOINTS



The advantage to the pin and block style of universal joint is a high strength to weight, size and cost ratio. These u-joints are manufactured from high strength billet alloy steel and then heat treated to obtain maximum strength. **Because the u-joints use pivot pins and blocks instead of sealed needle bearings, they must be checked and lubricated every time the vehicle is driven.** A rubber boot is also available to retain lubrication. The smaller sizes are ideal for fabricating shift linkage. Borgeson pin and block u-joints have a 30° maximum operating angle. **These u-joints are not for street use.**

1" FOR DRAG STEERING & SHIFT LINKAGE

Part Number	Description
Smooth X Smooth	
515964	1/2" Smooth Bore x 3/4" Smooth Bore
516262	5/8" Smooth Bore x 5/8" Smooth Bore
516462	5/8" Smooth Bore x 3/4" Smooth Bore
516464	3/4" Smooth Bore x 3/4" Smooth Bore
Spline X Smooth	
510962	9/16"-26 Spline x 5/8" Smooth Bore
510964	9/16"-26 Spline x 3/4" Smooth Bore

1"- Formula Car Shift Linkage, Drag Racing Steering

(not for circle track or road racing steering)

- 1/2", 5/8" or 3/4" smooth bore each end
- smooth bore with either 9/16"-26 or 5/8"-36 spline combination

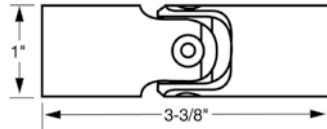

1-1/4" - Oval Track Steering

- 5/8" or 3/4" smooth bore each end
- Smooth bore and any spline and DD (except 9/16"-17, 9/16"-36, 1"-48, 1" DD)

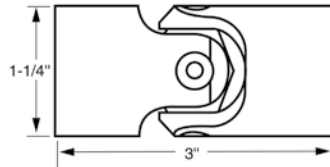

1-1/4" JOINTS

Part Number	Description
Smooth X Smooth	
526464	3/4" Smooth Bore x 3/4" Smooth Bore
Spline X Smooth	
520962	9/16"-26 Spline x 5/8" Smooth Bore
520964	9/16"-26 Spline x 3/4" Smooth Bore
523164	3/4"-30 Spline x 3/4" Smooth Bore
523464	3/4"-36 Spline x 3/4" Smooth Bore
524064	13/16"-36 x 3/4" Smooth Bore



INDUSTRIAL & SPECIALTY VEHICLE APPLICATIONS

Borgeson manufactures custom universal joints, steering shaft assemblies and OEM Saginaw manual steering gears for industrial, government and OEM applications. Borgeson has the personnel and technology to work with you to manufacture custom universal joints and shaft assemblies for your application. Contact our sales office for further information.

BORGESON

For AGRICULTURAL • AIRCRAFT • INDUSTRIAL
and MARINE APPLICATIONS

For INDUSTRY

Warner & Swasey Co., Pin-Drafter Intersecting Draw Frame equipped with Borgeson Universal Joints, for use in the Textile Industry.



For AIRCRAFT

Borgeson Universal Joints have many uses in the Aircraft Industry.



For AGRICULTURE

Food Machinery and Chemical Corp. Universal Corn Cutter, utilizing Borgeson Universal Joints.

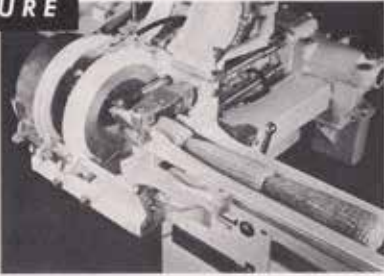

For MARINE APPLICATION

Borgeson Furnishes Universal Joints of Corrosion Resistant metal for Marine Applications.



TRADITIONAL STEERING COLUMNS & MOUNTS

Economy Stainless Steel Steering Column

Our economy stainless steel steering column is available in a polished or brushed finish. This column has a 1-3/4" tube with a 3" bell and will fit all standard 3-Bolt steering wheels. It has no provision for wiring. This column is available in an 18" Shorty version in addition to 26", 30", 34" lengths and has a 3/4"-36 spline shaft.

STAINLESS COLUMN PRICING MSRP

All Brushed Finish Stainless Columns

All Polished Finish Stainless Columns

STAINLESS COLUMN PART #'S

Polished	Brushed	Description
908054	908044	Stainless Steel Economy Column, 18" Length
908051	908041	Stainless Steel Economy Column, 26" Length
908052	908042	Stainless Steel Economy Column, 30" Length
908053	908043	Stainless Steel Economy Column, 34" Length



Steering Column Drops

Drops are available in three styles and various hole diameters to fit most columns. We machine these from solid billet aluminum. The adjustable swivel easily accommodates different column and dash angles. Available in 1-3/4", 2", 2-1/4" and 2-3/8" diameter holes and lengths of 2", 3", 4", 5", 6" and 7". The 2-3/8" drop has a notch to clear the wire harness cover on GM columns.

ALUMINUM COLUMN DROP PRICING MSRP

All Blank Style Column Drops

All Recessed Style Column Drops

All Open Style Column Drops

BILLET ALUMINUM COLUMN DROP PART #'S

Drop Size (Diameter x Length)	Solid Matte	Solid Polished	Open Matte	Open Polished	Recessed Matte	Recessed Polished
1-3/4" Diameter Column x 2" Drop	910172	911172	NA	NA	NA	NA
1-3/4" Diameter Column x 3" Drop	910173	911173	912173	913173	914173	915173
1-3/4" Diameter Column x 4" Drop	910174	911174	912174	913174	914174	915174
1-3/4" Diameter Column x 5" Drop	910175	911175	912175	913175	914175	915175
1-3/4" Diameter Column x 6" Drop	910176	911176	912176	913176	914176	915176
1-3/4" Diameter Column x 7" Drop	910177	911177	912177	913177	914177	915177
2" Diameter Column x 2" Drop	910202	911202	NA	NA	NA	NA
2" Diameter Column x 3" Drop	910203	911203	912203	913203	914203	915203
2" Diameter Column x 4" Drop	910204	911204	912204	913204	914204	915204
2" Diameter Column x 5" Drop	910205	911205	912205	913205	914205	915205
2" Diameter Column x 6" Drop	910206	911206	912206	913206	914206	915206
2" Diameter Column x 7" Drop	910207	911207	912207	913207	914207	915207
2-1/4" Diameter Column x 2" Drop	910222	911222	NA	NA	NA	NA
2-1/4" Diameter Column x 3" Drop	910223	911223	912223	913223	914223	915223
2-1/4" Diameter Column x 4" Drop	910224	911224	912224	913224	914224	915224
2-1/4" Diameter Column x 5" Drop	910225	911225	912225	913225	914225	915225
2-1/4" Diameter Column x 6" Drop	910226	911226	912226	913226	914226	915226
2-1/4" Diameter Column x 7" Drop	910227	911227	912227	913227	914227	915227
2-3/8" Diameter Column x 3" Drop	910233	911233	NA	NA	NA	NA
2-3/8" Diameter Column x 4" Drop	910234	911234	NA	NA	NA	NA

Solid or Split Swivel Floor Mounts

Our easy to install, solid full circle design slides over the end of the steering column. This provides a secure way to mount the column to the floor. The inner collar pivots to accommodate any floor angle. Available for 1-1/2", 1-3/4", 2" and 2-1/4" columns. A split design that separates in half to clear the column shift lever is also available; the split design can be installed on a column already in the vehicle; available for 2" and 2-1/4" columns. We manufacture all floor mounts from solid billet aluminum.

COLUMN FLOOR MOUNT PRICING MSRP

Solid Floor Mounts with Machined Finish

Solid Floor Mounts with Polished Finish

Split Floor Mounts with Machined Finish

Split Floor Mounts with Polished Finish

COLUMN FLOOR MOUNT PART #'S

Machined	Polished	Description
909013	909014	Solid Swivel 1-1/2" Diameter Column
909001	909002	Solid Swivel 1-3/4" Diameter Column
909003	909004	Solid Swivel 2" Diameter Column
909005	909006	Solid Swivel 2-1/4" Diameter Column
909007	909008	Split Swivel 2" Diameter Column
909009	909010	Split Swivel 2-1/4" Diameter Column



Solid Swivel

Split Swivel

Solid Style

Open Style

Recessed Style



NEW 1949-51 FORD CAR POWER CONVERSION



Power Steering By **BORGESON**
Steering You Forward

After years of effort, the steering specialists at Fatman Fab and Borgeson have found an answer to adding power steering to the factory '49-'51 Ford cars! A special reverse rotation box was the key, with a custom frame bracket and pitman arm that allow fitting to the stock or Fatman's Improved Steering Linkage kit. Although this is not recommended for use with the Flathead engine due to extremely tight exhaust clearance, small block Ford and Chevy engines will work well with recommended headers. Optional Column Saver kit will allow preserving the original column.

999062 Power steering conversion kit. Kit consists of a specially made Borgeson reverse rotation gearbox in a 14:1 ratio paired with a Fatman Fabrications custom fabricated bracket and pitman arm. Factory original steering column can be used with the conversion but will need to be shortened and adapted to the steering box. We offer a "Column Saver Kit" part #990044 for use with a stock column. Universal joints are available to use with an aftermarket column of your choice.

990044 Column Saver Kit. This handy kit includes everything needed to maintain the stock steering column in your 1949-1951 Ford when installing the power conversion box. Kit includes weld-on 3/4" DD shaft extension, lower mast jacket bushing, flat washers for shimming and universal joint to connect to the Borgeson conversion box. Detailed instructions included for shortening the factory column.

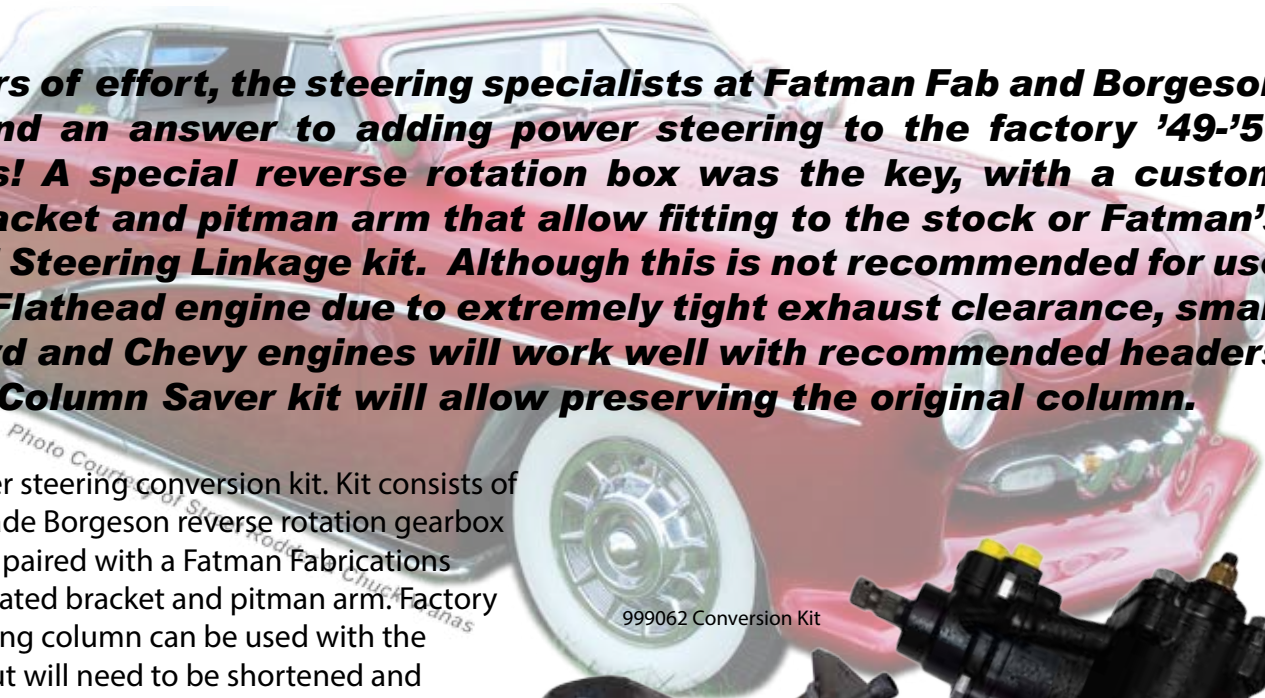

999062 Conversion Kit



990044 Column Saver Kit

1941-1951 FORD CONVERSION KIT AND ACCESSORIES	
Part #	Description
999062	Power Conversion Kit for 1949-1951 Ford Cars
990044	Original Steering Column "Column Saver Kit"
925108	Hose Kit, Borgeson 800110/800111 Box to Saginaw pump V-8
925121	Adapter Set. Adapts Conversion Box to -6AN for Custom Hose Applications
015225	1" DD X 11/16"-36 Spline Universal Joint for use with Aftermarket Columns



STREET ROD MANUAL STEERING BOXES

OEM Saginaw Manual Boxes

Borgeson is now the OEM manufacturer and re-manufacturer of Saginaw manual steering gears. Borgeson Saginaw manual steering boxes are assembled to the same demanding standards as our precision universal joints. Each box is carefully assembled, adjusted and inspected to our factory specifications. Borgeson offers both standard crossover steering boxes or reversed boxes for side steer applications. These steering boxes are made in the USA and have a 3 year warranty.

OEM Saginaw 140 Box

This is a real Vega box 100% made in the USA not a cheap copy. The Vega 140 is recommended only for vehicles under 2400 lbs. Steering ratio is 22:1. Reversed boxes are also available.



OEM Saginaw 525 Box

New OEM 525 boxes are available in either standard 24:1 ratio or a quick 16:1 ratio. Boxes are available with standard length or shortened input shafts. Available reversed for side steer applications.

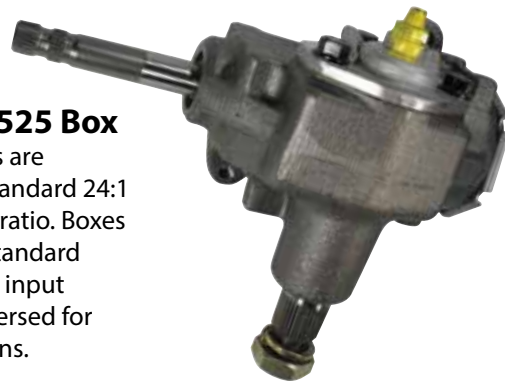

MANUAL BOXES FOR STREET ROD APPLICATIONS

Part #	Description
920004	Brand New OEM Saginaw 140 Vega Steering Box, Made in the USA, Standard 22:1 Ratio with a 5/8"-36 Input Spline and a 1"-32 Spline GM Pitman Shaft.
920007	Brand New Reversed Saginaw 140 Vega Steering Box for Side Steer Applications, Standard 22:1 Ratio with a 5/8"-36 Input Spline and a 1"-32 Spline GM Pitman Shaft.
920010	Brand New OEM Saginaw 525 Steering Box, Made in the USA, Standard 24:1 Ratio with a 3/4"-30 Input Spline and a 1-1/8"-32 Spline GM Pitman Shaft.
920009	Brand New Reversed Saginaw 525 Steering Box for Side Steer Applications, Standard 24:1 Ratio with a 3/4"-30 Input Spline and a 1-1/8"-32 Spline GM Pitman Shaft.
920040	Brand New OEM Saginaw 525 Steering Box, Made in the USA, Quick 16:1 Ratio with a 3/4"-36 Input Spline and a 1-1/8"-32 Spline GM Pitman Shaft.
920030	Brand New OEM Saginaw 525 Steering Box with Shortened Input for Street Rod Applications, 16:1 Quick Ratio with a 3/4"-36 Input Spline and a 1-1/8"-32 Spline GM Pitman Shaft.
920011	Brand New OEM 525 Steering Box with Shortened Input for Street Rod Applications, Standard 24:1 Ratio with a 3/4"-36 Input Spline and a 1-1/8"-32 Spline GM Pitman Shaft.

OEM Saginaw Side-Steer **NEW**

This is a brand new manufactured Saginaw 525 series gear that is designed specifically for side-steer applications. This is a true recirculating ball Saginaw manual steering box available in two different rotations to suit pitman arms that face either up or down.



SAGINAW SIDE-STEER SERIES

Part #	Description
920041	16:1 Ratio, Right Turn Makes Upward Facing Arm Pull Back
920042	16:1 Ratio, Right Turn Makes Upward Facing Arm Push Forward
920043	24:1 Ratio, Right Turn Makes Upward Facing Arm Pull Back
920044	24:1 Ratio, Right Turn Makes Upward Facing Arm Push Forward

PITMAN ARMS & STEERING BOX MOUNT

Part	Description
806003	122/525/605 Bendable Steel Flat (6" between centers)
806008	700/600/530 OEM Arm Cleaned, Inspected and Painted
806016	122/525/605 Steel, Flat, Bendable (7" between centers)
806018	700/600/530 Steel, Flat (7" between centers)
806010	Vega 140 Steel, Flat, Bendable (6" between centers)

*All Borgeson 700, 600, 525/122 and Vega steering boxes have the same three bolt pattern and can use this bracket. Not all steering boxes share the same mount pattern.

Power Steering Boxes & Accessories

Borgeson offers the Saginaw/Delphi 700 series in three different ratios, 2 fixed and one variable. Borgeson utilizes later model steering gears for more favorable steering feel, ratio and response. The variable ratio offers a quick final ratio with only 3 turns lock-to-lock but is not overly sensitive on-center for stable highway driving. The #800205 Variable Ratio 700 gear is an excellent upgrade for 65 and up GM Muscle cars looking to update their steering.

Note: All 1979 and earlier GM cars will require a new or rag joint coupler to use these later model boxes.

POWER STEERING BOXES & ACCESSORIES

Part #	Description
800220	Remanufactured Delphi 700 Power Steering Box, 12.7:1 Ratio, 3/4-30 Spline
800221	Remanufactured Delphi 700 Power Steering Box, 14:1 Ratio, 3/4-30 Spline
800205	Remanufactured Delphi 700 Power Steering Box, Variable Ratio, 3/4-30 Spline
990012	3/4-30 Spline Rag Joint Coupler
925103	2 Piece P/S Hose Kit, Rubber, GM Pump to GM Box
925203	2 Piece P/S Hose Kit, Braided Stainless, GM Pump to GM Box
800310	GM Power Steering Pump with Keyway, Black
800311	GM Power Steering Pump with Keyway, Chrome
802400	P/S Pump Bracket, Steel, SBC/SWP
802402	P/S Pump Bracket, Steel, SBC/LWP
802403	P/S Pump Bracket, Steel, BBC/SWP
802407	P/S Pump Bracket, Steel, BBC/LWP
801001	P/S Pump Pulley GM 2-Row Keyway Style
801101	5-3/4" P/S Pump Pulley, Billet Aluminum, 1-Row, Polished
801102	4-5/8" P/S Pump Pulley, Billet Aluminum, 1-Row, Polished
801201	5-3/4" P/S Pump Pulley, Billet Aluminum, 1-Row, Machined Finish
801202	4-5/8" P/S Pump Pulley, Billet Aluminum, 1-Row, Machined Finish



GM 700 Power Box
 #800205 16:13:1 Variable Ratio
 #800220 12.7:1 Ratio
 #800221 14:1 Ratio



#990012 Rag Joint Coupler



OEM Saginaw Manual Steering Boxes

Borgeson is now the OEM manufacturer of Saginaw manual steering gears. Borgeson Saginaw manual steering boxes are assembled to the same demanding standards as our precision u-joints. Each box is carefully assembled, adjusted and inspected to our factory specifications.

SAGINAW MANUAL STEERING BOXES

Part #	Description
920010	New OEM 525 Manual Steering Box, 24:1 Ratio 3/4"-30 Spline
920040	New OEM Saginaw 525 Steering Box, 16:1 Ratio 3/4"-36 Spline
920055	New OEM Saginaw 122 Steering Box,, 24:1 Ratio 3/4"-36 Spline
920004	New OEM Saginaw 140 Vega Steering Box, 22:1 Ratio 5/8"-36 Spline



Saginaw 525/122

Power to Manual Conversion Kits

Borgeson gives you a great way to shed up to 28 pounds and free up some extra horsepower with our complete power to manual conversion kits. Each direct fit conversion kit includes a new OEM Saginaw 525 box, pitman arm and half rag joint. Quick ratio steering boxes are also available.

POWER TO MANUAL CONVERSION KITS

Part #	Description
999001	1978-1988 Malibu and 1982-1992 Camaro
999002	1964-1967 Chevelle, 442, GTO
999003	1970-1981 Camaro and 1975-1979 Nova
999004	1968-1972 Chevelle, 442, GTO



Saginaw 140

Manual Conversion Kit



POWER STEERING PUMPS & ACCESSORIES

Self Contained Power Steering Pumps, Brackets & Pulleys

These are new manufactured Saginaw style self-contained power steering pumps made to precise tolerances.. Pumps are available with either a black powder coated or chrome reservoir. We also offer pumps preset to the lower operating pressure for Mustang rack and pinions, and pumps with two returns for Hydro-Boost brake applications. Our pump brackets are all designed for Saginaw self-contained pumps with two mounting locations on the rear of the reservoir. Brackets are designed with simplicity and ease of installation in mind.

See photos below for return tube locations.



SAGINAW POWER STEERING PUMPS

Part #	Description
800310	Black Powder Coated Self-Contained Power Steering Pump with Keyway Shaft. Pump Pressure is 1200-1350 PSI with a 2.7-3.5 GPM Flow Rate.
800311	Chrome Self-Contained Power Steering Pump with Keyway Shaft. Pump Pressure is 1200-1350 PSI with a 2.7-3.5 GPM Flow Rate.
800312	Black Powder Coated Self-Contained Power Steering Pump with Keyway Shaft for Mustang R&P. Pump Pressure is 950-1050 PSI with a 2.7-3.5 GPM Flow Rate.
800313	Chrome Self-Contained Power Steering Pump with Keyway Shaft for Mustang R&P. Pump Pressure is 950-1050 PSI with a 2.7-3.5 GPM Flow Rate.
800322	Black Powder Coated Self-Contained Power Steering Pump with 1 Row Pulley and Press-On Shaft. Pump Pressure is 1200-1350 PSI with a 2.7-3.5 GPM Flow Rate.
800323	Black Powder Coated Self-Contained P/S Pump with Two Returns for Hydro-Boost, Press-On Shaft. Pump Pressure is 1450-1550 PSI with a 3.0-3.5 GPM Flow Rate.
800324	Black Powder Coated Self-Contained Power Steering Pump with Keyway Shaft. Pump Pressure is 1200-1350 PSI with a 2.7-3.5 GPM Flow Rate.
800325	Black Powder Coated Self-Contained Power Steering Pump with Press-On Shaft. Pump Pressure is 1200-1350 PSI with a 2.7-3.5 GPM Flow Rate.
800326	Black Powder Coated Self-Contained Power Steering Pump with Press-On Shaft. Pump Pressure is 1200-1350 PSI with a 2.7-3.5 GPM Flow Rate.
800327	Black Powder Coated Self-Contained Power Steering Pump with 1 Row Pulley and Press-On Shaft. Pump Pressure is 1200-1350 PSI with a 2.7-3.5 GPM Flow Rate.
800329	Black Powder Coated Self-Contained Power Steering Pump with 1 Row Pulley and Press-On Shaft. Pump Pressure is 1200-1350 PSI with a 2.7-3.5 GPM Flow Rate.



#800310,#800312,#800327



#800311,#800313



#800323



#800324,#800325#800329



#800322,#800326

SELF CONTAINED PUMP BRACKETS

Part #	Description
802400	Self Contained P/S Pump Bracket, SBC/SWP
802402	Self Contained P/S Pump Bracket, SBC/LWP
802403	Self Contained P/S Pump Bracket, BBC/SWP
802407	Self Contained P/S Pump Bracket, BBC/LWP
802409	Self Contained P/S Pump Bracket, SBF/289/302/351W
802410	Self Contained P/S Pump Bracket, Ford 200/250 I-6
802411	Self Contained P/S Pump Bracket, Ford 292/312 Y Block
802412	Self Contained P/S Pump Bracket, Mopar 318/340/360

#802402 SBC/LWP



POWER STEERING PULLEYS

Part #	Description
801001	Steel P/S Pulley, 2-Row with Keyway, Painted Black, 5-3/4"
801105	Steel P/S Pulley, 1-Row Press-On, Painted Black, 5-3/4"
801201	Aluminum P/S Pulley, 1-Row with Keyway, 5-3/4"
801202	Aluminum P/S Pulley, 1-Row with Keyway, 4-5/8"
801203	Aluminum Type II P/S Pulley, 1-Row Press-on, 4-5/8"
801101	Polished Aluminum P/S Pulley, 1-Row with Keyway, 5-3/4"
801102	Polished Aluminum P/S Pulley, 1-Row with Keyway, 4-5/8"
801103	Polished Aluminum Type II P/S Pulley, 1-Row Press-on, 4-5/8"



POWER STEERING PUMPS & ACCESSORIES

Saginaw Pump Kits for Fords

Borgeson manufactures Saginaw self contained power steering pump kits for popular Ford applications. Kits include new Saginaw style self-contained pump with new powder coated reservoir, cap, 1- row pulley and bracket.



SAGINAW PUMP KITS FOR FORDS

Part #	Description
800330	Saginaw Pump Kit for Ford 289/302/351W
800334	Saginaw Pump Kit for Ford 200/250 In-Line 6 Cylinder
800336	Saginaw Pump Kit for Ford FE 390/428
800335	Saginaw Pump Kit for Ford 292/312 Y-Block
801150	2 Row Aluminum add on crank pulley for Y-Block

Hi-Pressure Problem Solver



Pressure Reducing Kit

This kit contains tools, parts and instructions to reduce the pressure of GM pumps to operate rack & pinions or to increase steering "feel". Fits both Self-Contained & Remote Reservoir Type II pumps.

PRESSURE REDUCING KIT

899001	Pressure Reducing Kit for Self Contained and GM Type II Pumps
--------	---

Power Steering Hose Kits

We have rubber and stainless steel hoses for many popular applications. The braided stainless steel hose kits use a high pressure Teflon lined hose and will require final cutting and assembly.

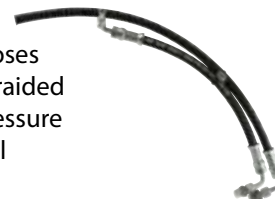

POWER STEERING HOSE KITS

Part #	Description
925101	Rubber Hose Kit, 2-Piece, GM Pump to '74-'78 Mustang Rack
925102	Rubber Hose Kit, 2-Piece, GM Pump to '79-'97 Mustang Rack
925103	Rubber Hose Kit, 2-Piece, GM Pump to GM Box
925201	Stainless Steel Hose Kit, 2-Piece, GM Pump to '74-'78 Mustang Rack
925202	Stainless Steel Hose Kit, 2-Piece, GM Pump to '79-'97 Mustang Rack
925203	Stainless Steel Hose Kit, 2-Piece, GM Pump to GM Box

Remote Power Steering Reservoirs

Our billet aluminum power steering reservoir is available in either a polished or unpolished finish. The reservoir has an internal baffle plate and includes an O-Ring sealed cap and mounting bracket. It uses standard NPT fittings.



REMOTE POWER STEERING RESERVOIR

Part #	Description
800600	Remote reservoir with bracket, Polished
800601	Remote reservoir with bracket, Unpolished

1962-79 MOPAR

Mopar Quick Ratio Modern Power Steering Conversion

Borgeson has developed a modern quick ratio power steering box for the 62-79 Mopar cars. This modern power steering box bolts directly to the stock k-frame and fits to your stock pitman arm. The Borgeson quick ratio power steering box offers a 14:1 ratio with only 3.5 turns lock-to-lock, 10lb. weight savings over a stock power box (23lbs. vs. 33lbs), increased exhaust clearance and a tight modern feel to the steering. The Borgeson conversion box can be used in both factory manual and power steering applications.

This box is offered in both 1-1/8" and 1-1/4" pitman shaft sizes. Be sure to measure to insure you receive the correct box.

Steering Column Modifications

The original steering column shaft will need to be cut and shortened for installation. Connection to the box is then made by drilling and pinning our #036425 Mopar vibration reducing universal joint coupler to the shortened steering column shaft. Drill bit and pins included with coupler.

1962-1979 MOPAR

Power Conversion Box & Components

800126	Power Steering Conversion Box 62-79 Mopar 1-1/8" Sector Shaft
800127	Power Steering Conversion Box 62-79 Mopar 1-1/4" Sector Shaft
036425	Steering Column Adapter for Factory Columns
925121	Fitting Adapter Set, Adapts Conversion Box to -6AN Fitting
925113	Power Steering Hose Kit, Saginaw Pump to Mopar Conversion Box
802412	Self Contained P/S Pump Bracket, Mopar 318/340/360
800322	New Mopar Saginaw Style P/S Pump, Press-On style with Pulley

#800126 Power Box



#036425 Coupler



Power Box Size Comparison

Stock Power #800126 Box



1958-64 CHEVY CAR

Modern Power Steering Conversion

Borgeson now offers a modern integral power steering conversion for your 1958-1964 full size Chevy. The Borgeson conversion box is a remanufactured GM Delphi 600 integral power steering gearbox. The Delphi 600 represents the latest generation of integral power steering gearbox technology with true modern power steering feel, feedback and a quick 14:1 ratio.

Borgeson has remanufactured this box to bolt directly to the factory mounting location and to fit the stock pitman arm. This box has been positioned to clear the larger four core radiators. The idler arm will need to be rotated to match the new angle of the steering box. A new universal joint and steering shaft will be required for connection to the stock column. Cars with factory power steering will require a drag link adapter or a manual center link.

348/409 Applications will require use of a remote style power steering pump.

1958-1964 CHEVY IMPALA

Part #	Description
--------	-------------

Power Steering Conversion Box & Accessories

800106	58-64 Chevy Remanufactured Delphi 600, Power Conversion Box
990007	58-64 Chevy Drag Link Adapter for cars with factory power steering
013446	Universal Joint, 3/4"-36 X 17MM DD For connection to power box
409216	Steering Shaft, 3/4"-36 Spline connects 013446 Joint to stock column
925103	2 Piece Rubber P/S Hose Kit, GM Pump to GM Box
800310	GM Power Steering Pump with Keyway
801001	P/S Pump Pulley GM 2-Row Keyway Style 5-3/4" Diameter Steel
801202	P/S Pump Pulley 1-Row Keyway Style 4-5/8" Diameter Aluminum
802400	P/S Pump Bracket, Steel, SBC/SWP
802402	P/S Pump Bracket, Steel, SBC/LWP
802403	P/S Pump Bracket, Steel, BBC/SWP

Complete Power Steering Conversion Kits

999014	58-64 Power Conversion Kit. SBC/SWP, Stock Column
999015	58-64 Power Conversion Kit. Box, Joint and Shaft Only

ididit Direct Replacement Columns Available



#999014 Conversion Kit



Power Conversion Box

1962-72 CHEVY II

1962-1966 Modern Power Steering Conversion (Floor Shift Only)

Borgeson offers a modern quick ratio power steering conversion box for your 1962-1966 Chevy II Nova. Borgeson has remanufactured this box to bolt directly to the factory mounting location and to fit the stock steering linkage without any interference or modification of the frame or shock tower. **The original factory column will need to be shortened for clearance of the power steering box.** Cars with factory power steering will require either a drag link adapter or a manual steering center link.

IMPORTANT INSTALLATION NOTES:

- Power conversion box is intended for use with stock steering columns only.
- **Floor Shift Only.** Any stock column can be modified to fit, however column shift is not possible with added length of steering box.
- Borgeson vibration reducing column shaft #990041 is recommended for installation.

1962-1966 CHEVY II POWER CONVERSION

Part#	Description
-------	-------------

800117	Power Steering Conversion Box, 62-66 Chevy II Nova
990041	Steering Column Shaft for Power Conversion 62-66 Chevy II Nova
800310	New Saginaw Style P/S Pump with Keyway
802400	Self Contained P/S Pump Bracket, SBC/SWP
801001	Steel P/S Pulley, 2-Row with Keyway, Painted Black, 5-3/4"
925108	P/S Hose Kit, Rubber, Conversion box to Saginaw pump V-8
990005	62-66 Nova Manual Drag Link Adapter for cars with factory P/S

1962-1972 CHEVY II MANUAL BOXES

Part #	Description
--------	-------------

920055	68-72 Chevy II, OEM Original Replacement
920040	68-72 Chevy II, Quick Ratio 16:1, Direct Replacement



#800117 Conversion Box

#990041 Column Shaft



Modern Power Steering Conversion

Borgeson offers an integral power steering conversion for your 1955-1957 Chevy. The Borgeson conversion box is a remanufactured GM Delphi 600 integral power steering gearbox. The Delphi 600 represents the latest generation of integral power steering gearbox technology with true modern power steering feel, feedback and a sporty 12.7:1 ratio. Borgeson has remanufactured this box to bolt directly to the factory mounting location and to fit the stock pitman arm. Conversion requires shortening the stock steering column. (Details below)

Cars with factory power steering will require drag link adapter #990001 or manual steering linkage.

STEERING COLUMN MODIFICATIONS

Floor shift cars with stock column will need to trim the outer column tube back to the firewall. Replacement steering column shaft #990008 can then be used with rag joint #055034 to connect to the conversion box.

Column shift cars with stock column will require extensive modifications and sectioning. We have available pre shortened stock columns for the 55-56 and 57 cars. Shortened stock columns require rag joint #055049 to connect to the conversion box.

Aftermarket columns. The available direct replacement aftermarket columns are the proper length to use with our box and will connect with either rag joint #055034 or 055052 depending on the column shaft. **ididit Direct Replacement Columns Available.**

1955-1957 CHEVY

Part # Description

Column Floor Mounts & Column Shaft

909011	55-57 Chevy Deluxe Floor Mount for 2" Column
909012	55-57 Chevy Deluxe Floor Mount Polished for 2" Column
909017	55-57 Chevy Economy Floor Mount for 2" Column
990008	Replacement Column Shaft for 55-57 Chevy Fits stock wheel, 3/4"-36 Splined

Power Steering Conversion Box & Accessories

800105	55-57 Chevy Delphi 600 Gear Power Steering Conversion Box
990001	55-57 Chevy Manual Drag Link Adapter for cars with factory power steering
055034	Rag Joint, 18MM-DD X 3/4-36, Power Box to 3/4"-36 Spline column
055052	Rag Joint, 18MM-DD X 1"-DD, Power Box to 1"-DD column
925103	2 Piece Rubber P/S Hose Kit, GM Pump to GM Box
800310	GM Power Steering Pump with Keyway
801001	P/S Pump Pulley GM 2-Row Keyway Style
802404	P/S Pump Bracket for 55-57 Chevy with Front Motor Mounts
802400	P/S Pump Bracket, Steel, SBC/SWP
802402	P/S Pump Bracket, Steel, SBC/LWP

Complete Power Steering Conversion Kits

999009	55-57 Power Conversion Kit. SBC, Front Motor Mounts, 3/4"-36 Column
999010	55-57 Power Conversion Kit. SBC, Front Motor Mounts, 1"-DD Column
999005	55-57 Power Conversion Kit. SBC/SWP, 3/4"-36 Column
999006	55-57 Power Conversion Kit. SBC/SWP, 1"-DD Column
999008	55-57 Power Conversion Kit. SBC/LWP, 1"-DD Column



#999005 Conversion Kit.

#909017 Economy Floor Mount



#909012 Deluxe Floor Mount



#990001 Drag Link Adapter



Saginaw Manual Box Rebuild Kits

These major rebuild kits include all necessary components to completely rebuild your original Tri-5 manual steering box. Kits are available in two different ratios with your choice of original long input shaft or a shortened input shaft for use with aftermarket steering columns. Will require some specialty tools. Instructions included.

1955-1957 CHEVY MANUAL BOX REBUILD KITS

Part # Description

921012	55-57 Chevy, Manual Rebuild Kit, 24:1 Ratio, Long Input
921013	55-57 Chevy, Manual Rebuild Kit, 16:1 Ratio, Long Input
921014	55-57 Chevy, Manual Rebuild Kit, 24:1 Ratio 3/4-30 Spline, Short Input
921015	55-57 Chevy, Manual Rebuild Kit, 16:1 Ratio 3/4-36 Spline, Short Input



Manual Steering Box Rebuild Kits

1963-82 CORVETTE

Corvette Modern Power Steering Conversion

Borgeson offers a modern integral power steering conversion for your 1963-1982 classic Corvette. The Borgeson conversion box is a remanufactured GM Delphi 600 integral power steering gearbox. The Delphi 600 represents the latest generation of integral power steering gearbox technology with true modern power steering feel, feedback and a sporty 12.7:1 ratio. Borgeson has remanufactured this box to bolt directly to the factory mounting location and to fit the stock pitman arm. The factory column will need to be collapsed or shortened approximately 2.5" for clearance of conversion box. (Details below)

Cars with factory power steering will require drag link adapter #990002 or manual steering linkage.

STEERING COLUMN MODIFICATIONS

1963-1966 Cars will need to trim approximately 2.5" off the splined steering column shaft for installation. Conversion box will then connect to the stock column with rag joint #055034 (Must leave 3/4" of spline to properly engage the rag joint)

1967-1982 Cars have a factory collapsible steering column. Gently tap on the spline column shaft with a rubber mallet to collapse the shaft in on itself for the needed 2.5" of clearance. Conversion box will then connect to column with rag joint #055043.

1963-1982 CORVETTE POWER CONVERSION

Part #	Description
--------	-------------

Power Steering Conversion Box & Accessories

800108	63-82 Corvette Delphi 600 Gear Power Steering Conversion Box
990002	63-82 Corvette Manual Drag Link Adapter for cars with factory power steering
055034	Rag Joint 18MM-DD X 3/4-36 for connection of Box to 3/4"-36 Spline column
055043	Rag Joint 18MM-DD X 1"-48 for connection of Box to 1"-48 Spline column
925103	2 Piece Rubber P/S Hose Kit, GM Pump to GM Box
925203	2 Piece Stainless P/S Hose Kit, GM Pump to GM Box
800310	GM Power Steering Pump with Keyway, Painted Black
800311	GM Power Steering Pump with Keyway, Chrome
801005	Corvette P/S Pump Pulley, 2-Row Keyway Style
802400	P/S Pump Bracket, Steel, SBC/SWP
802408	Corvette P/S Pump Bracket, Steel, BBC/SWP

Complete Power Steering Conversion Kits

999016	63-66 Power Conversion Kit SBC/SWP, Manual Steering, Stock Column
999017	67-82 Power Conversion Kit SBC/SWP, Manual Steering, Stock Column
999031	63-66 Power Conversion Kit for cars with factory P/S
999032	67-82 Power Conversion Kit for cars with factory P/S



#800108 Conversion Box

#999016 Conversion Kit



#999032 Conversion Kit



OEM Corvette Manual Steering Boxes **NEW**

Borgeson is now the OEM manufacturer and re-manufacturer of Saginaw manual steering gears for the 1963-1982 Corvettes. Borgeson has both new OEM boxes and OEM remanufactured. Borgeson steering boxes are assembled to the same demanding standards as our precision u-joints. Each box is carefully assembled, adjusted and inspected to our factory specifications.

#920038 Manual Box



1963-1982 CORVETTE MANUAL BOXES

Part #	Description
--------	-------------

920038	68-82 Corvette, New OEM Manual Steering Box, 3/4-30 Spline
920039	63-67 Corvette, New OEM Manual Steering Box, 3/4-36 Spline

1965-1970 Power Steering Conversions

Borgeson offers modern integral power steering conversions for 1965-1970 classic Mustangs. The Borgeson conversion box is a new manufactured modern integral power steering gearbox. The Borgeson integral power steering gearbox provides true modern power steering feel, feedback and a quick 14:1 ratio. Borgeson has manufactured this box to bolt directly to the factory mounting location and to fit the stock pitman arm. The column will need to be collapsed or shortened for clearance of conversion box. (Details below) Factory power steering cars will require either manual drag link #990050 or drag link adapter #990003

NOTE: 1967 Mustang owners must measure the sector shaft to see if it is 1" or 1-1/8" prior to purchase.

NOTE: Power conversion box will not fit with factory Z-Bar clutch linkage.

STEERING COLUMN MODIFICATIONS

1965-1967 Cars will need to trim the outer column tube for clearance of the rag joint and use replacement inner column shaft #990040. Conversion box will then connect to the stock column with rag joint #052534

1968-1970 Cars have a factory collapsible steering column. Gently tap on the rag joint flange with a rubber mallet to collapse the shaft in on itself for the needed clearance. Conversion box will then connect to column with half rag joint #990016.

1971-1973 Power Steering Upgrade

Borgeson now offers a modern Delphi 600 series power steering upgrade for the 1971-1973 classic Mustangs. The Borgeson upgrade is a remanufactured modern Delphi 600 series power steering gearbox with true modern power steering feel, feedback and a quick 14:1 ratio. Installation requires our #990018 rag joint connector and either #925118 or 925119 power steering hose kit.

1965-1970 COMPLETE CONVERSION KITS

Part #	Description
999020	1965-66 Mustang with Manual Steering and 289/302/351 W
999021	1968-70 Mustang with Manual Steering and 289/302/351 W
999023	1965-66 Mustang with Power Steering and V-8
999024	1968-70 Mustang with Power Steering V-8
999025	1968-70 Mustang with Power Steering I-6
999026	1965-66 Mustang with Manual Steering and 200/250 I-6
999027	1968-70 Mustang with Manual Steering and 22/250 I-6



1965-1973 POWER BOX & COMPONENTS

Part#	Description
800110	Power Steering Conversion Box with 1" Sector Shaft, '65-'67
800111	Power Steering Conversion Box with 1-1/8" Sector Shaft, '67-'70
800128	Power Steering Upgrade Box for 1971-1973 Mustangs
990040	65-67 Replacement Column Shaft with Floor mount
052534	Complete Rag Joint for 65-67 Mustang with Conversion Box
990016	1/2 Rag Joint for 68-70 Mustang with Conversion Box
990018	1/2 Rag Joint for 71-73 Mustangs with Upgrade Box
925107	Hose Kit, Borgeson 800110/800111 Box to Ford Pump V-8
925108	Hose Kit, Borgeson 800110/800111 Box to Saginaw pump V-8
925109	Hose Kit, Borgeson 800110/800111 Box to Ford Pump I-6
925110	Hose Kit, Borgeson 800110/800111 Box to Saginaw Pump I-6
925118	Hose Kit, Borgeson 800128 Box to Ford Pump V-8
925119	Hose Kit, Borgeson 800128 Box to Saginaw Pump V-8
990051	65-66 Clutch Z-Bar to clear power conversion box 289/302/351 W
800330	289/302/351W P/S Pump upgrade includes: pump, bracket & pulley
800336	390/428 FE P/S Pump upgrade includes: pump, bracket & pulley
800334	200/250 I-6 P/S Pump upgrade includes: pump, bracket & pulley
990003	67-70 Mustang Drag Link Adapter, Replaces Control Valve

#990051 Manual Clutch Linkage



1979-2004 Mustang Steering Shafts

Borgeson makes direct replacement steering assemblies for 79-04 Mustangs. The factory rag joint is eliminated in all assemblies giving additional header clearance. Available with or without vibration reducers. Our precision needle bearing u-joints give a great positive feel to the steering.

1979-2004 MUSTANG STEERING SHAFTS

Manual	Power	Description
000655	000656	79-93 Steel without Vibration Reducer
000657	000658	79-93 Steel, with Vibration Reducer
000662	000663	79-93 Aluminum, without Vibration Reducer
N/A	000650	94-04 Rack to OEM Column without Vibration Reducer
N/A	000651	94-04 Rack to OEM Column with Vibration Reducer

1952-64 FORD FULL SIZE CAR

Modern Power Steering Conversion

Borgeson has developed an integral power steering conversion box for the 1952-1964 Ford full size cars. The Borgeson conversion box is a new manufactured modern integral power steering gearbox. The Borgeson integral power steering gearbox provides true modern power steering feel, feedback and a quick 14:1 ratio. Borgeson has manufactured this box to bolt directly to the factory mounting location and connects to the stock manual steering linkage. The steering column will need to be shortened for installation of this conversion box. (Details below)

Cars with factory Bendix style power steering will require either manual steering linkage or a drag link adapter.

STEERING COLUMN MODIFICATIONS

1952-1957 & All Column Shift cars a steel coupler #312500 must be welded to a cut off inner column shaft. The outer column tube will be able to fit over the coupler leaving enough column tube to mount the shift linkage.

1958-1964 Floor shift applications we recommend the use of a rag joint #052549. The cut off column shaft will need to be ground into a DD profile to connect to the rag joint.

This conversion box fits the following Ford full size models:

- 1952-1956 Crestline, Customline, Mainline
- 1957-1960 Custom
- 1957-1962 Fairlane
- 1958-1964 Galaxie
- 1955-1957 Thunderbird

Box will also fit Mercury vehicles sharing the same platform.

1952-64 FORD FULL SIZE	
Part#	Description
800115	Ford Full Sized Power Conversion Box
CALL	Complete Conversion Kit, Full Size Ford with Manual Steering, 292/312 Y-Block Only
CALL	Complete Conversion Kit, Full Size Ford with Manual Steering, 289/302/351W Only
800335	P/S Pump Upgrade, 292/312 Y-Block, Includes Pump, Bracket and Pulley
800330	P/S Pump Upgrade, 289/302/351W, Includes Pump, Bracket and Pulley
800336	P/S Pump Upgrade, FE390/428, Includes Pump, Bracket and Pulley
925108	Power Steering Hose Kit, 2-Pc Rubber, GM Pump to Conversion Box V-8 Only
925121	Steering Box Hose Adapter Set-6AN (Required for custom hose applications)
801150	2-Row Add-On Crank Pulley, Adds 2nd Row for P/S on 292/312 Y-Block
990004	Manual Drag Link Adapter for 1961-1964 Full Sized Ford Only
802409	Power Steering Pump Bracket, Steel, Ford 289/302/351W, Saginaw Style Pump
802411	Power Steering Pump Bracket, Steel, Ford 292/312 Y-Block, Saginaw Style Pump
052549	Rag Joint Coupler 1 1/4"-36 x 3/4"-DD
312500	Steel Coupler 1 1/4"-36 x 3/4" Smooth



Modern Power Steering Conversion

Borgeson offers an integral power steering conversion for your 1964-1977 Ford mid size. The Borgeson conversion box is a new manufactured modern integral power steering gearbox. The Borgeson integral power steering gearbox provides true modern power steering feel, feedback and a quick 14:1 ratio. Borgeson has manufactured this box to bolt directly to the factory mounting location and to fit the stock pitman arm. The column will need to be collapsed or shortened for clearance of conversion box. (Details below) Cars with factory Bendix style power steering will require either manual steering linkage or a drag link adapter.

STEERING COLUMN MODIFICATIONS

Stock column shift cars have variations throughout the years. We have not done in house fitting on column shift cars. Installations have been completed using our #312500 coupler. This fits within the column tube and may leave room for the factory shift linkage.

1964-1967 floor shift applications, you will need to trim away the outer column tube and cut off the inner steering column shaft. The column shaft will need to be ground into a DD profile to connect to rag joint #052549.

1968-1977 floor shift applications, you will need to trim away the outer column tube. The inner steering column shaft with rag joint flange will then collapse in on itself for clearance. Attach the shortened column to the box with half rag joint part #990016.

This conversion box will fit the following years and models:

- 1964-1970 Ford Fairlane
- 1966-1970 Ford Falcon**
- 1966-1970 Ford Ranchero & Falcon Ranchero
- 1968-1971 Ford Torino & Gran Torino
- 1970-1977 Ford Maverick

Box will also fit Mercury vehicles sharing the same platform.

**1960-1965 Falcons use either our #800110 or #800111 call for details.



#800114 Power Conversion Box

1964-77 FORD MID SIZE CARS

Part #	Description
800114	Ford Mid-Sized Power Conversion Box
800330	P/S Pump Upgrade, 289/302/351W, Includes Pump, Bracket and Pulley
800336	P/S Pump Upgrade, FE 390/428 P/S, Includes Pump, Bracket and Pulley
999052	Complete Conversion Kit, 1968-1977 Ford Mid-Size with Manual Steering, 289/302/351W Only
999053	Complete Conversion Kit, 1968-1977 Ford Mid-Size with Power Steering, Small Block & Big Block
800334	P/S Pump Upgrade, I-6 200/250, Includes Pump, Bracket and Pulley
802409	Power Steering Pump Bracket, Steel, Ford 289/302/351W, Saginaw Style Pump.
802410	Power Steering Pump Bracket, Steel, Ford 200/250, Saginaw Style Pump.
925107	Power Steering Hose Kit, 2 Pc Rubber, Ford Pump to Conversion Box, V-8 Only
925108	Power Steering Hose Kit, 2 Pc Rubber, GM Pump to Conversion Box, V-8 Only
925109	Power Steering Hose Kit, 2 Pc Rubber, Ford Pump to Conversion Box, I-6 Only
925110	Power Steering Hose Kit, 2 Pc Rubber, GM Pump to Conversion Box, I-6 Only
925121	Steering Box Hose Adapter Set-6AN (Required for custom hose applications)
990003	Manual Drag Link Adapter, Mid-Sized Ford
990016	Steering Coupler, 1/2 Rag Joint, Steering Box Side, 11/16-36 Spline, With Disc
052549	Rag Joint Coupler 1 1/8"-36 x 3/4"-DD



#999052 Complete Conversion Kit

MADE IN THE USA SINCE 1914
3 YEAR WARRANTY ON STEERING BOXES

1970-04 FORD TRUCK

If you have tried replacing the worn-out steering on your Ford, you've probably found that many OEM replacement steering assemblies are no longer available. Borgeson manufactures heavy duty bolt-in replacement assemblies for many model years of Ford pickups and Broncos. Borgeson incorporates a telescoping shaft that adds a measure of safety to the steering system. Ford has had many length variations over the years and sometimes within model years. Borgeson has accommodated this by making an assembly which can be trimmed down to get the exact fit for your application. This added length will also accommodate aftermarket body lifts. Borgeson also offers an upgrade to our standard assembly that incorporates a vibration reducer that greatly reduces the road shock felt through the steering wheel.

FORD TRUCK STEERING ASSEMBLIES

Part #	Description
000970	70-79 Full Size Pickup
000975	70-79 Full Size Pickup with Vibration Reducer Upgrade
000977	78-79 F150, F250, Bronco with Rag Joint Flange
000941	Replacement Rubber Rag Joint and Hardware
000980	80-91 Full Size
000985	80-91 Full Size with Vibration Reducer Upgrade
000981	92-96 F150, F250, F350
000982	97-04 F150, '97-'99 F250



Rubber Rag Joint and Hardware.

1966-1977 BRONCO

Bronco Power Steering Box & Components

Borgeson offers an integral power steering conversion for your 1966-1977 Bronco. The Borgeson conversion box is a modern power steering gearbox that has been modified to bolt directly to the factory mounting location and to fit the stock pitman arm. A new universal joint will be required for connection to the stock column and a new hose kit for connection to the pump of your choice. Complete kits are available for the most popular applications.

1966-1977 BRONCO STEERING

Part #	Description
Replacement Steering Shafts	
000973	66-75 Bronco, Manual Steering (Column must be modified)
000976	73-75 Bronco, Power Steering (Rag Joint Column)
Power Steering Conversion Box & Accessories	
800125	66-77 Bronco Modern Power Steering Conversion Box
999059	66-77 Bronco Power Conversion Kit SBF 289/302/351W
999060	66-77 Bronco Power Conversion Kit 200/250 In-Line 6 Cylinder
014925	Universal Joint 3/4"-DD to 11/16"-36 Conversion Box Only
000820	76-77 Bronco Steering Shaft with Borgeson Conversion Box
000821	66-75 Bronco Steering Shaft M/S with Borgeson Conversion Box
000822	73-75 Bronco Steering Shaft P/S with Borgeson Conversion Box
925111	2 Piece Rubber P/S Hose Kit, Ford Pump to Conversion Box
925112	2 Piece Rubber P/S Hose Kit, Saginaw Pump to Conversion Box
800330	SBF Saginaw P/S Pump upgrade. Includes: pump, bracket and pulley
800334	Ford I-6 Saginaw P/S Pump upgrade. Includes: pump, bracket and pulley



Bronco Power Conversion Kit

1972-1986 Jeep CJ 1987-2006 Wrangler and 1974-2000 Jeep Trucks

Jeep's original steering shaft assemblies were not designed for the added stress of body lifts and oversized tires. Borgeson's replacement assemblies offer a heavy duty telescoping shaft with either two precision needle bearing u-joints or a vibration reducer and a u-joint. The steering assembly is easy to install with common hand tools. Once installed, you will experience much tighter and more responsive steering. Steering shafts have a 5 year warranty.

JEEP STEERING SHAFTS

Part #	Description
000903	72-75 CJ, Manual
000904	72-75 CJ, Power
000905	76-86 CJ, Manual
000910	76-86 CJ, Power
000915	76-86 CJ, Manual with Vibration Reducer Upgrade
000920	76-86 CJ, Power with Vibration Reducer Upgrade
000925	87-95 Wrangler, Power & Manual
000926	87-95 Wrangler, Power & Manual W/O Vibration Reducer
000890	74-83 Cherokee (SJ) Power with Rag Joint Flange
000890	74-91 Wagoneer (SJ) Power with Rag Joint Flange
000941	Rubber Rag Joint and Hardware
000893	84-00 Cherokee/Wagoneer (XJ)
000896	92-95 Grand Cherokee (ZJ)
000872	97-00 TJ Upper Shaft
000873	01-06 TJ Upper Shaft
000874	97-02 TJ Manual Lower Shaft
000875	97-02 TJ Power Lower Shaft
000876	03-06 TJ Power & Manual Lower Shaft



1972-02 JEEP STEERING BOXES & PUMPS

Borgeson steering boxes & pumps are assembled to the same demanding standards as our precision u-joints, far surpassing the OEM standards. Each box is chemically cleaned, inspected and refinished. All components are thoroughly inspected and replaced or re-machined as needed. Each is then carefully assembled, adjusted and inspected to our factory specifications.

JEEP STEERING BOXES & PUMPS

Part #	Description
Jeep Steering Boxes	
920055	1972-86 Jeep CJ, New OEM Replacement Manual Steering Box
920010	1987-02 Jeep Wrangler, New OEM Manual Steering Box
Jeep Power Steering Pumps	
800324	1972-1974 Jeep CJ5, CJ6, Wagoneer Power Steering Pump
800325	1975-1983 Jeep CJ5, CJ7 Power Steering Pump
800326	1983-1990 Jeep Cherokee & Wagoneer Power Steering Pump
800323	P/S Pump Press-On style with two returns for Hydro-Boost

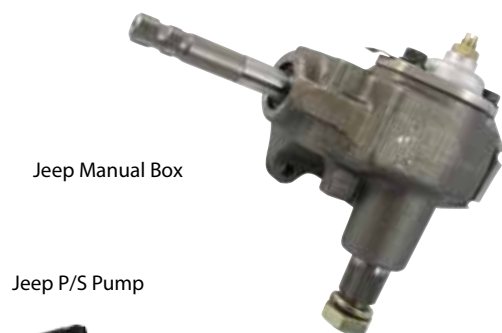

Jeep Manual Box

Jeep P/S Pump



1979-08 DODGE TRUCK

Dodge Full Size Truck Shafts

Full size Dodge Pickups and Ramchargers have a type of steering coupler that has shown signs of wear in as little as 4000 miles, depending on how the truck is used. This wear causes play in the truck's steering. It's even more noticeable if your truck is used for plowing, towing or if oversized tires have been installed. Replacing the worn steering shaft with another OEM shaft only gives you a temporary fix. The Borgeson steering shaft assembly replaces the loose OEM parts with precision needle bearing u-joints and a telescopic shaft.

DODGE PICK-UP STEERING ASSEMBLIES

Part #	Description
000940	79-93 Full Size with Rag Joint Flange
000941	Replacement Rubber Rag Joint with Hardware
000943	79-93 Extreme-Duty 2-Joint System (verify Column*)
000945	94 Full Size
000950	95-02 Full Size
000951	03-08 2500 & 3500 4WD Models
000952	03-08 1500, 2500 & 3500 2WD (Except 1500 4X4 Mega Cab)
000951	06-08 1500 4WD Mega Cab

*Column must have Removable Rag Joint

REPLACEMENT RAG JOINT



DODGE POWER STEERING UPGRADES

Borgeson 1994-02 Hi-Flow P/S Pump

Part #800328 Manufactured from *all new components* this is a direct replacement Hi-Flow power steering pump for the 1994-2002 Dodge Ram 2500 & 3500 trucks with the Cummins Turbo Diesel motor. This pump has the output pressure/flow calibrated to 1450-1550 PSI and 3.5 GPM to provide your Ram with all of the power its steering needs. Includes new powder coated reservoir, cap and drive key.

Part # 800328



Borgeson Dodge Box for 2003-08

Part # 800123 Borgeson has sourced and adapted this brand new massive "6-bolt" power steering box for the 2003-2008 Dodge trucks. This box has a massive pitman shaft with the largest bearing available for support. The top of the pitman shaft is supported by a 6-bolt top cover for ultimate pitman shaft stability. The Borgeson "Dodge Box" offers the largest piston diameter for the most available power assist and a modern variable valve that allows for stable highway driving and effortless parking and maneuvering. *This box has a pitman shaft that is compatible with all OEM and dropped pitman arms that fit the stock box.*

Part # 800123, 03-08 Dodge Box

Installation Note: Use of a Borgeson #000951 aftermarket steering shaft is recommended for ease of installation. To use this box with the stock steering shaft two flats must be ground on the steering box adapter to match the orientation flats on the stock steering shaft.



DODGE POWER STEERING

Part #	Description
800123	03-08 Dodge Box Power Steering Box Upgrade.
800328	P/S Pump Upgrade for 94-02 Dodge Trucks with Cummins Diesel
925116	P/S Hose kit for 94-96 Dodge Diesel Trucks with Vacuum Brakes
925117	P/S Hose Kit for 97-02 Dodge Diesel Trucks with Hydro-Boost Brakes

1973-08 CHEVY/GMC TRUCK

1973-1994 Chevy & GMC

Full Size Trucks and SUVs

Factory steering shafts for many GM models are no longer available from GM, but your worn out steering shafts can now be replaced. The Borgeson direct replacement assemblies consist of a telescoping shaft, a needle bearing u-joint and a rag joint. A Borgeson heavy-duty truck assembly will fix that loose, wandering steering for good.

EXTREME-DUTY

TWO-JOINT STEERING ASSEMBLY 1973-1994

A two-joint system that eliminates the factory rag joint is also available. You should use the two-joint system if you use your truck for extra heavy-duty off-roading or have a body lift installed.

1999-2008 Chevy & GMC

Full Size Trucks and SUVs

You may already have experienced a "clunking or ratcheting" feel in the steering of your 1999-2008 Chevy truck. Borgeson's direct replacement assembly is a permanent solution to the problem.

CHEVY & GMC FULL SIZE STEERING ASSEMBLIES

Part #	Description
000930	73-78 Full Size with Rag Joint Flange
000932	73-76 Extreme-Duty with 2 Universal Joints
000933	77-78 Extreme-Duty with 2 Universal Joints
000934	79-91 Full Size with Rag Joint Flange
000935	79-94 Extreme-Duty with 2 Universal Joints
000936	92-94 with Universal Joint and Complete Rag Joint
000937	99-08 Full Size Truck & SUV Upper Shaft
000941	Replacement Rubber Rag Joint with Hardware
920023	1968-78 2WD OEM Remanufactured Manual Steering Box



CUSTOM STEERING SHAFT ASSEMBLIES **NEW**

Using a Borgeson telescopic shaft and the proper universal joints will allow you to build a custom steering shaft for many applications not listed. Telescopic shafts are available in 24" (telescopes form 21"-27") and 36" (telescopes form 33"-39") lengths. The telescopic shafts can be easily trimmed up to 10". Telescopic shafts have a 1" DD connection on one end and a 3/4" DD connection on the other. By selection the proper universal joint for each end you can put together a custom assembly for your application. The below listings are just a small sampling of the most popular universal joints. Many more options are available in the universal joint section of our catalog. If you can't find the correct joint or have any questions feel free to give us a call.



CUSTOM STEERING SHAFT ASSEMBLIES

Part #	Description
450024	24" Telescopic Shaft, Telescopes from 21"-27"
450036	36" Telescopic Shaft, Telescopes from 33"-39"
015252	1" DD X 1" DD Universal Joint, for 1" DD Column Connections
013452	3/4"-36 Spline X 1" DD Universal Joint, for 3/4"-36 Spline Column Connections
014352	1"-48 Spline X 1" DD Universal Joint, for 1"-48 Spline Column Connections
014952	3/4" DD X 1" DD Universal Joint, for 3/4" DD Column Connections
014931	3/4" DD X 3/4"-30 Spline Universal Joint, for 3/4"-30 Spline Box Connections
013449	3/4" DD X 3/4"-36 Spline Universal Joint, for 3/4"-36 Spline Box Connections
014940	3/4" DD X 13/16"-36 Spline Universal Joint, for 13/16"-36 Spline Box Connections
014925	3/4" DD X 11/16"-36 Spline Universal Joint, for 11/16"-36 Spline Box Connections



STEERING SYSTEM DESIGN

Steering System Design

Often the steering system is designed late in the building process. We recommend that the steering be mocked up at the time the engine and exhaust components are installed. Positioning of the column, shafts, and u-joints with respect to the engine, exhaust and steering box early on can help in selecting the correct parts. With our wide selection of u-joints, shafts, and vibration reducers, any system can be designed or modified to result in a car that is not only safe, but a pleasure to drive. Keeping a system simple is the best course, but even a system with up to 10 u-joints can be designed as long as the proper phasing and supports are used. **Remember to use a support bearing if more than two joints are used.**

Shaft Support Placement

Any time more than two universal joints are used in a system, a shaft support is required to prevent the shafts from looping. In a system with 3 u-joints, one support is required. For each additional u-joint, an additional support will be needed. In a 3 joint system it is best to locate the shaft support as close to the center u-joint as possible. If one of the shafts is significantly longer than the other, it is best to locate the support on the longer shaft.

Vibration Reducer Placement

Vibration reducers can substantially reduce, and even eliminate annoying road vibration from being transmitted to the steering wheel. Location of the reducer in a system is very important in order to take full advantage of its effects. In a two joint system, the vibration reducer can be installed at either end without any loss of effectiveness. In a system with one or more shaft supports however, the vibration reducer should be located on the column side of the supports. A shaft support located on the steering column side of a vibration reducer can pick up vibration, bypass the reducer, and transmit the vibration to the steering wheel.

Shorty Columns

A great way to free up some much needed leg room in your street rod is by using a shorty column. This moves the steering column up under the dash and gives you much more leg/pedal space resulting in a much more comfortable ride.

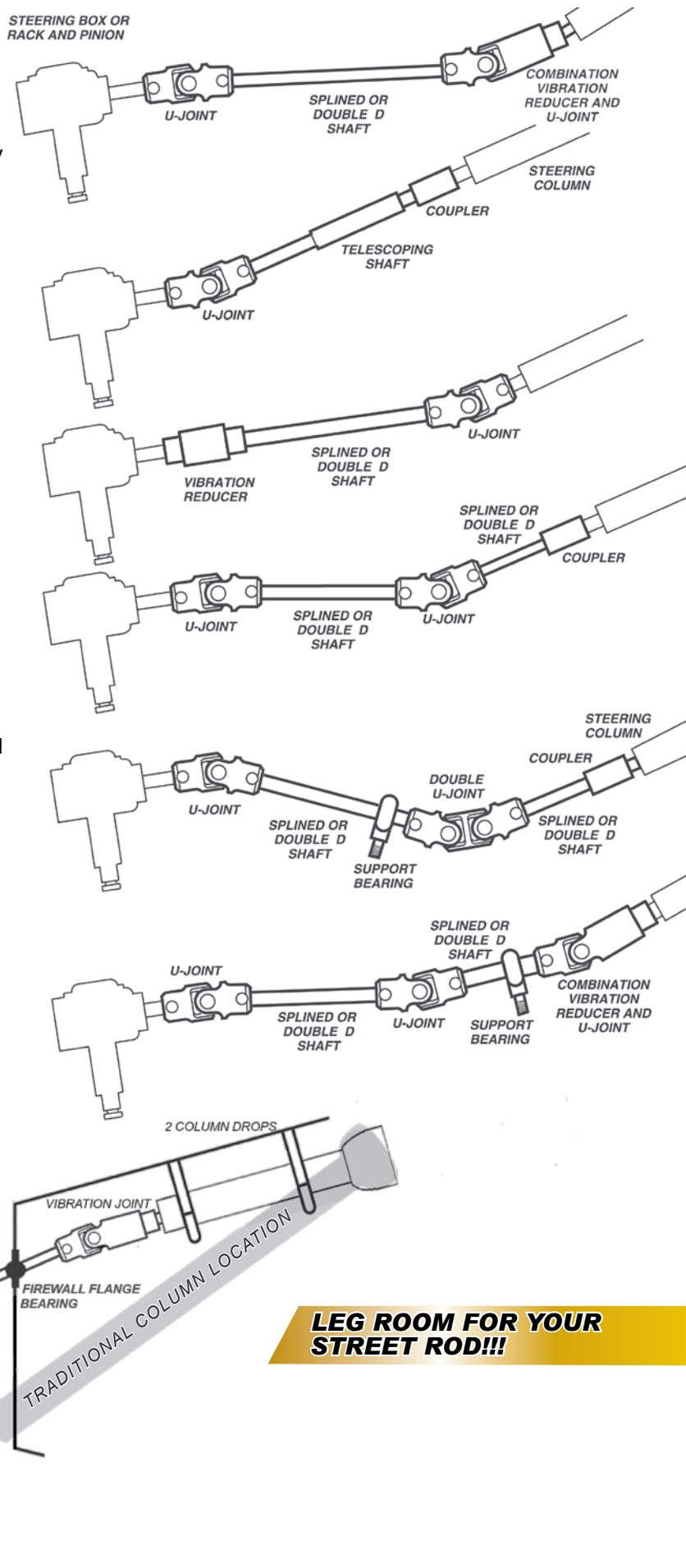

LEG ROOM FOR YOUR STREET ROD!!!

Steering Column Length and Column Drop Size

Before determining the column length, it is important to have your seat and pedals in the final locations. Using a pie tin tacked to a wooden dowel is an excellent way to decide on steering column position and length. With one person sitting in the car and holding the "steering wheel" in position, another person can take measurements of column length and position. Keep in mind, many traditional style steering wheels are flat, while other aftermarket wheels are dished. This is also the perfect time to determine how much drop you'll need to put the column in a comfortable driving position. Measure from the mounting surface on the dash to the center of the steering column. This is the length of the drop you will need.

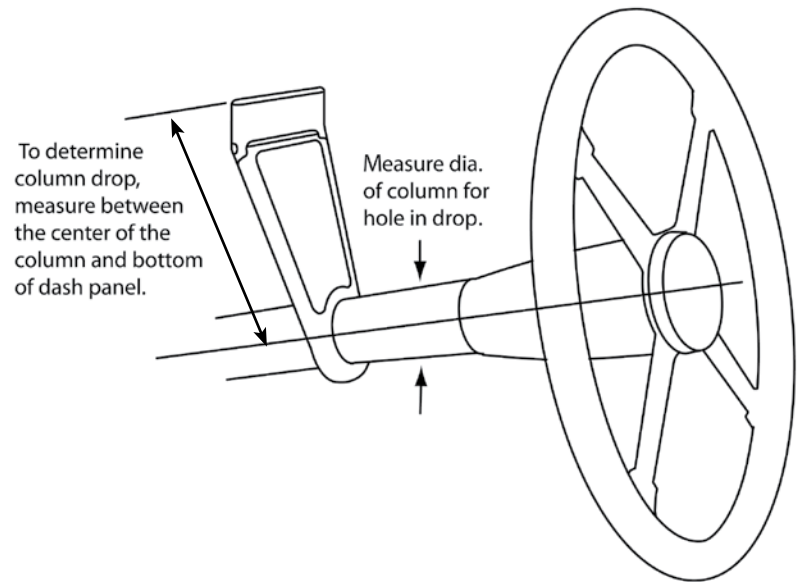

Steering Box Installation Angle

One thing frequently overlooked when building or modifying a car is the position of the steering box. Steering boxes are often positioned with the input shaft level creating a much more complex steering linkage. A great way to simplify your steering linkage is to position the steering box with the input shaft angled up toward the steering column. This method has been used by the OEM's for years to simplify the connection to the steering column.



Steering Ratio

Steering box ratio. This is the relationship between input motion and output motion on the steering box. The ratio is expressed as 24:1, 22:1, 16:1, etc. For example, in a 24:1 ratio box, the pitman shaft rotates one degree for every 24 degrees of input shaft rotation. The higher the first number, the more input shaft rotation is required to get the same amount of output shaft rotation. Dividing the first number in the ratio by four, gives the number of turns lock to lock.

Steering ratio and effort. A quicker ratio steering box will have fewer turns of the steering wheel lock-to-lock but this does have an effect on drivability. In manual steering applications a quick ratio box, while enhancing the way the car feels at speed, will greatly increase steering effort during low speed and parking. In power steering applications it is quite common for quicker ratios to be used as the power assist overcomes the added steering effort. Selecting too quick of a ratio without properly building the suspension can result in a diving feel during 5-10 MPH turns.

Variable Ratio Steering. True variable ratio steering is accomplished with the gear cut of the sector shaft and rack block inside the steering gear. The center tooth of a variable ratio power steering gear box is cut at a slower ratio, this makes the on center feel and reaction of a variable ratio box more stable at highway speeds. The pitch of the sector shaft gear then changes to a quicker ratio off center. This gives quicker response when more turning is required like parking, yet minimizes the overall turns lock-to-lock.



Pitman Arm Length

Steering speed can be adjusted by box ratio or pitman arm length. The longer the pitman arm, the quicker the steering will be. That is, a longer pitman arm means less steering wheel movement is required to produce the same amount of front wheel movement. So if you are looking to speed up or slow down the steering, changing the pitman arm is an easy way to do it.

STEERING SYSTEM DESIGN HOW TO...

Determine splined shaft length with two u-joints:

1. Measure the distance from the end of the column to the box/rack (Dimension C).
2. Subtract 3" from this measurement.
3. Order the next even size shaft (Dimension B).

Note: We stock stainless and polished stainless shafting in 1/4" increments up to 24"

EXAMPLE If "C" is 18" —subtract 3" (1-1/2" for each joint). "B" is 15". Order a 16" shaft and trim a total of 1" from the shaft, either from one or both ends.

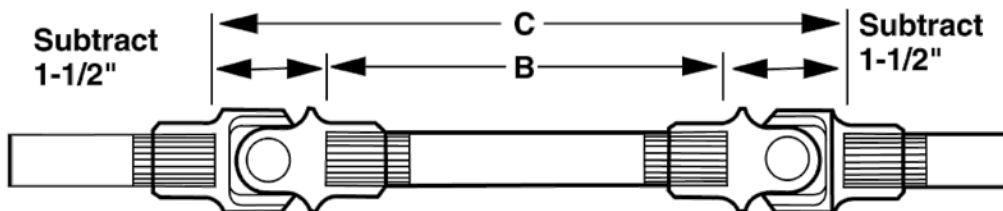

Determine splined shaft length with one u-joint and u-joint/vibration reducer combination.

1. Measure the distance from the end of the column to the box/rack (Dimension C).
2. Subtract 4" from this measurement.
3. Order the next even size shaft (Dimension B).

Note: We stock stainless and polished stainless shafting in 1/4" increments up to 24"

EXAMPLE If "C" is 19" —subtract 4" (1-1/2" for a joint and 2-1/2" for the vibration reducer). "B" is 15". Order a 16" shaft and trim 1" from the shaft, either from one or both ends.

Determine splined shaft length with three or more u-joints.

1. Buy the u-joints first.
2. Install a joint on the column and one on the box/rack.
3. Use dowels or PVC pipe and mock up the system around obstacles.
4. Order the correct shaft lengths based on dowel/PVC lengths.

Add a vibration reducer to an existing steering system.

There are various ways of adding a vibration reducer to a system. Because of the difference in shafts, u-joints, racks, boxes, and columns, we recommend you call our technical support staff. We can suggest options that will result in the best steering system for you.



Rag Joint Angles of Operation

Rag joints are designed to dampen vibrations, they are not designed to accommodate an angle. **If you do not have a straight connection a rag joint should NOT be used.**

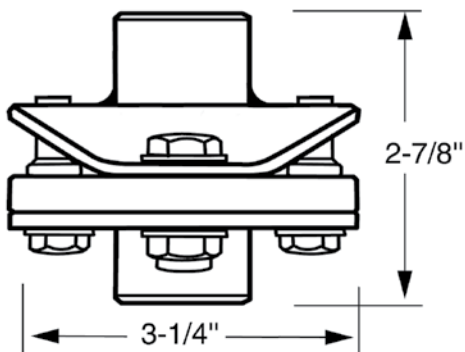

U-joint Angles of Operation

The Borgeson needle bearing u-joints will operate smoothly up to 35°. The double needle bearing u-joints will operate smoothly up to 70°. The u-joints must not be altered in any way. Pin and block style u-joints will operate at 30° smoothly.

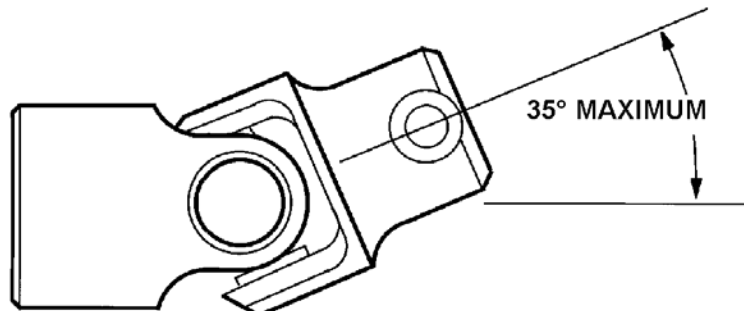

Splines and Irregular Shapes: the STRONGEST Method.

Detroit uses irregularly shaped shafts such as splined or a Double D configuration and inserts them into a similarly shaped hole with practically no play and then secures them by staking or clamping. Since steering failures are practically unheard of in modern production cars, one should strongly consider this method as having significant merit.

Borgeson offers splined shafts and joints which give the option of easy disassembly when repairs on the vehicle become necessary. Another advantage is the ability to rotate the shaft in relation to the u-joint in small increments. This makes it easier to position the u-joints in the correct relationship to each other.

A flat should be filed on the splined shaft where the set screw will clamp (figure A). This will prevent damage to the spline and allow for easier disassembly. Always lock the set screw with a lock nut, Loc-Tite or similar product. The shaft must be flush with the inside of the yoke (figure B), not so short that it sacrifices strength or so long that it interferes with the center workings of the joint.

To determine the spline size of a component, measure the outside diameter and count the number of splines. If there is a flat spot on the shaft and some of the splines are missing, (figure C) count halfway around where there are splines and double that number. We need to know how many teeth are in a theoretical full circle. If you have something unusual or you're unsure about measuring the spline, make an impression of it in clay and send it to us.

A Double D (figure D) shaft has two flats on the shaft that correspond to two flats in the female end of the u-joint. The disadvantage of this style is the lack of adjustability because the shaft can only be rotated 180°. The Double D shaft should have a dimple machined on the shaft for the set screw to clamp to (figure D).

Pinning

Common practice is to use two 3/16" diameter roll pins in each yoke at right angles to each other and approximately 3/8" apart. (figure E) An even stronger connection can be made by using hardened shear pins. Pinning can be used when the shaft can be removed from the vehicle and supported properly when inserting the pins. Driving pins in while the assembly is in the car could cause damage. The major drawback to pinning is that a 3/4" diameter shaft is weakened by 30%, smaller shafts are weakened to an even greater extent.

If you are considering using bolts instead of roll pins, don't. **NEVER USE BOLTS!** Always use roll pins. Roll pins are driven in and fit very tightly in the drilled hole. Bolts often fit loosely inside the drilled hole and repeated back and forth movement, even though very slight, can cause the bolt to work harden and fail.

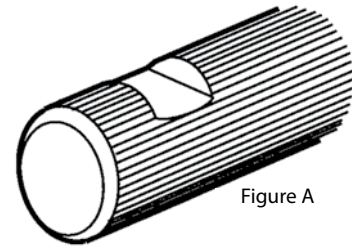

Figure A

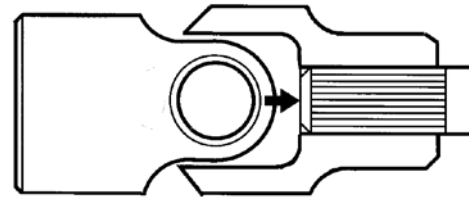

Figure B

Count the number of splines of half the circumference and double that number for total

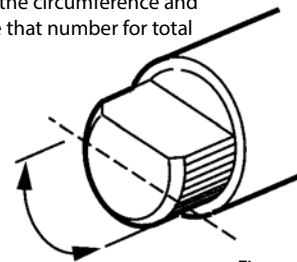

Figure C

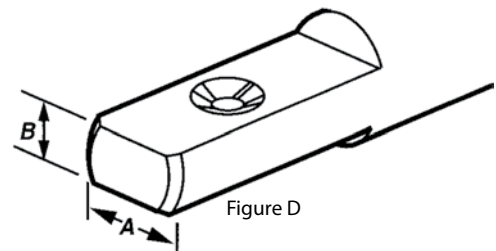

Figure D

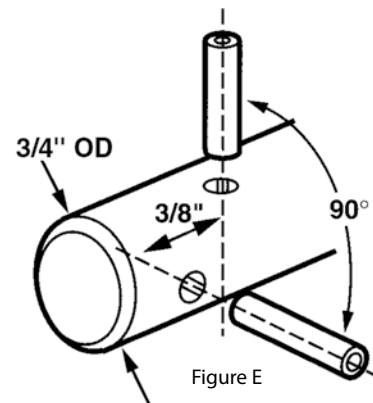

Figure E

STEERING SYSTEM DESIGN

CAUTION: Collapsibility

Every steering system should include some means of directing energy away from the driver in the event of a collision. One method of reducing the chance of this happening is to intentionally design angles into the steering system so that the force of a collision deflects the column away from the driver. A second method is to use the Borgeson telescopic intermediate shaft.

Problem:

Here is a straight column *WITHOUT* a collapsible intermediate shaft. Without a collapsible shaft, the column may be forced into the passenger compartment in the event of a collision.

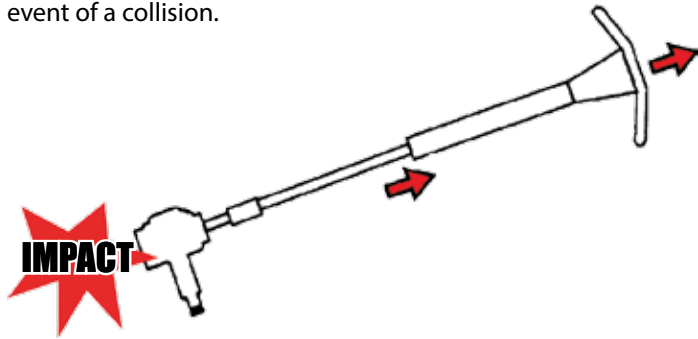

Solution: A

With a telescopic intermediate shaft the column slides together, compacting before it gets a chance to enter the passenger compartment.

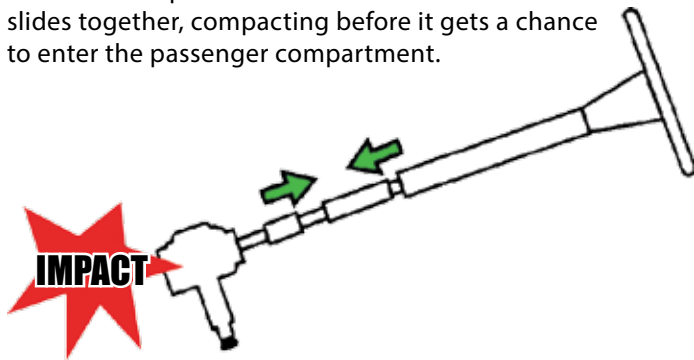

Solution: B

Here is an example of a steering system with angular collapsibility. An angle designed into steering shaft deflects the column upward upon impact.

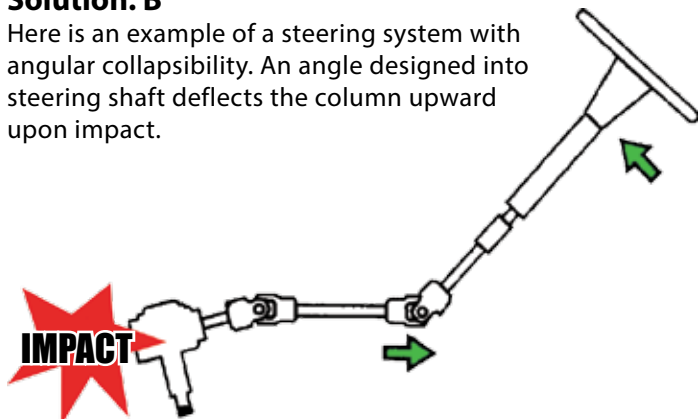

CAUTION: Shaft Size

BORGESON DOES NOT RECOMMEND USING LESS THAN 3/4" DIAMETER SHAFTS

All Borgeson spline and DD shafts are 3/4" diameter. We will not sell a shaft with a smaller diameter due to safety considerations. A 5/8" shaft is 42% weaker than a 3/4" shaft and can be twisted with a 14" steering wheel.

Borgeson does not recommend using tubing for a steering connection. It is unsafe to pin and there are too many wall thicknesses and alloys available to insure proper strength.

U-Joint Orientation

When two joints are used on a shaft, the forks of the yokes closest to each other should be in line, or "in phase." Premature wear or binding can result if the u-joints are not phased properly. Sometimes if the u-joints are at a severe angle, even if they are phased correctly, a hard spot in the steering may occur for no apparent reason. If this happens, index the u-joints two or three splines in one direction. The hard spot should disappear or be minimized.

CORRECT PHASING



INCORRECT PHASING

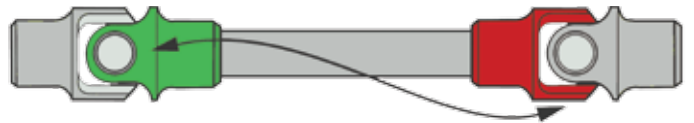

CAUTION: Do Not Use Flex Cable

Another less common (and definitely not recommended) method of getting from the column to the rack or box is to use flex cabling from a Pinto (this cable is no longer available from Ford). Ford only used these for a couple of years before switching to joints and shafts, which should tell you something. When a heavier engine is put into a larger heavier car, a flex cable is not reliable.



CAUTION: Welding

Welding joints is a common practice in racing, however, it is not a method we at Borgeson would recommend. Hairline cracks, which may be all but invisible to the unaided eye, could cause a weld to fail under severe stress. It may also be illegal in some states to weld steering system components on a car used on the street. Improper grounding can cause damage which will result in the failure of the steering. Overheating, which can occur at relatively low temperatures, can distort the yoke and melt the grease out of the needle bearings or damage the seals. This can prevent the joint from operating freely and it may fail. Cooling a weld too quickly can cause cracks, leading to sudden failure. Also, welding is a permanent connection that makes disassembly almost impossible should it become necessary. **Caution: Welding on steering components is illegal in some states. Check first.**

CAUTION: Keying and Set Screws

Using a key, as is done in many industrial applications, can transmit power effectively from the shaft to the joint. A key, however, is not suitable to take sudden shock (such as from a pothole or accident) which can distort or shear the key or shaft keyway. This may cause play to develop in the system or, even worse, failure. It should be noted that in industrial applications, keys are designed to shear, preventing damage to expensive components. In automotive applications a sheared key will cause extensive damage by causing a loss of control of the vehicle. **Set screws should never be used to secure smooth bore joints.** They should only be used as a method to prevent a splined or Double D shaft from disengaging from the joint. An indentation or flat should be made for the set screw on splined or DD shafts.

CAUTION: Bolts for Connection

NEVER USE BOLTS! Always use roll pins. Roll pins are driven in and fit very tightly in the drilled hole. Bolts often fit loosely inside the drilled hole and repeated back and forth movement, even though very slight, can cause the bolt to work harden and fail.

CAUTION: Corvair Steering Boxes

Corvairs were rear-engined cars; this means there was very little weight on the front tires. The steering box used in these cars was a very light duty box. **It is not recommended for use in a street rod with the engine in the front. Steering gear failure could cause a severe accident.**

CAUTION: Vega Steering Boxes

We recommend a maximum weight limit of 2400 lbs. for a vehicle using a Saginaw 140 (Vega) steering Box. We recommend the 525 Saginaw box for vehicles exceeding 2400 lbs.

Diagnosing Power Steering Problems

When trying to determine what is causing a problem in your power steering, keep this in mind: If the problem occurs only in one direction, the problem is probably in the box or rack. If the problem is in both directions, it is most likely the pump, dirty fluid or hoses. Be sure there are no kinks or obstructions in your power steering hoses and that they are the right inside diameter for the application.

Dirty Steering System

Before changing any single component of the steering system, inspect the cleanliness of your system. Dirty or black fluid can quickly ruin new steering components. If changing the box or rack, rub your finger on the inside of the reservoir. If it isn't clean, you must flush the pump and hoses with clean fluid before installing new components.

Bleeding Power Steering

All power steering systems are designed to be self-bleeding, but sometimes they need a little help. After installing new components, fill the reservoir and let it sit for a few minutes. Raise the front end of the vehicle and turn the wheels back and forth slowly with the engine off to allow the steering box to draw fluid. Keep the reservoir full. When the fluid level stops dropping, start the vehicle and continue turning the wheels. When the fluid level remains constant the system is fully bled. Put cardboard under the front tires while testing your steering system. The cardboard will slide on the floor and prevent wearing flat spots on the tires from excessive turning of the wheels while not moving.

Steering Box Adjustment

All Borgeson steering boxes are set at the factory to the proper specifications. Any adjustments of the box beyond that will void the warranty and cause premature wear on the steering box. Please do not try to adjust your steering box. Please contact us if you feel your steering box needs adjustment.

Power Steering Pressure

GM power steering pumps will produce up to 1,500 PSI. We recommend 1,200 PSI for steering box applications and 800–900 PSI for Mustang rack & pinions. If a pump is generating too much pressure for the rack or box you are using, the steering will be over assisted resulting in twitchy steering at speed. This can be corrected by adjusting the pumps internal pressure valve. To properly adjust this pressure order part #899001-Pressure Reducing Kit.



STEERING TROUBLESHOOTING

Many factors influence power steering troubleshooting. Here is a list of common steering and driving complaints, their causes, and some suggestions to fix it.

Road Wander:

Vehicle wanders left/right without any definite input from the steering wheel requiring constant small correction to drive straight.

- Low or unequal tire pressure.
- Steering linkage from column to box or rack loose or worn
- Front-end alignment out of specification. (Inadequate positive Caster)
- Steering box or rack worn or out of adjustment
- Steering tie rod ends worn or loose

No Recovery or Return to Center:

Vehicle fails to return to center after a turn or requires steering input to return to center.

- Binding of steering linkage or components
- Front-end alignment out of specification. (Inadequate positive Caster)
- Steering box or rack improperly adjusted.

Over-steering / Darting:

Vehicle over steers and is overly sensitive to all steering wheel input requiring constant correction.

- Excessive P/S pump pressure / mismatched components.
- Steering linkage from column to box or rack loose or worn
- Steering box or rack worn or out of adjustment

Lost motion at steering wheel:

Excessive free play felt in the steering wheel before the wheels actually begin to turn.

- Steering linkage from column to box or rack loose or worn
- Steering box or rack worn or out of adjustment
- Steering tie rod ends worn or loose
- Steering gear loose on frame

High Steering Effort in both directions:

An abnormal amount of force is required to turn the wheels in both directions.

- Low tire pressure
- Low P/S fluid level
- Insufficient P/S pump pressure and flow
- Excessive P/S fluid temperature
- Binding of steering linkage or components

Intermittent / Loss of power steering:

After servicing the P/S system you experience either a loss of power steering or intermittent assist.

- Low P/S fluid level
- P/S Belt broken or slipping
- Air trapped in the P/S system
- Dirt or contaminants trapped in the P/S pump bypass valve



BORGESON
Steering You Forward

STEERING BOX AND SPLINE IDENTIFICATION GUIDE



For Splined Shafts with a Flat
Count the number of splines
of half the circumference and
double that number for total

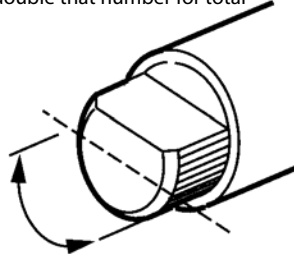

Popular Splines And Double D Applications

All Measurements can be +/- .015". Precision measuring equipment should be used.

Column Application	Description	Size	Diameter	Splines	Double D Flats
GM Column	Small Spline	3/4"-36	.735	36	
	Large Spline	1"-48	.985	48	
	Small Double D	3/4" DD	.750		.550
	Large Double D	1" DD	.993		.790
Ford Column	Small Spline	3/4"-36	.735	36	
	Small Double D	3/4" DD	.750		.550
	Large Double D	1" DD	.993		.790
Other Manufacturers	International	1"-48	.985	48	
	Ididit-aluminum	1"-48	.985	48	
	Ididit-steel	1" DD	.993		.790
	Flaming River	1" DD (standard)	.993		.790
	Borgeson	3/4"-36	.735	36	
Boxes & Racks Application	Description	Size	Diameter	Splines	Double D Flats
Chrysler Box or Rack	Chrysler	9/16"-17	.562	17	
	Chrysler	9/16"-26	.562	26	
	Chrysler	9/16"-36	.562	36	
	Chrysler	5/8"-36 C*	.625	36	
	Chrysler	11/16"-36	.687	36	
	Chrysler	3/4"-36	.735	36	
	Chrysler	13/16"-36	.812	36	
	Chrysler Omni	9/16"-26	.562	26	
GM Manual Box	Corvaire	5/8"-36	.625	36	
	Vega (model 140)	5/8"-36	.625	36	
	Corvette ('63-67)	3/4"-36	.728	36	
	Corvette ('68-83)	3/4"-30	.735	30	
	('58-64)	3/4"-36	.735	36	
	Model 122 ('65-85)	3/4"-30 or 3/4"-36	.730	30 or 36	
	Model 525 ('86 & later)	3/4"-30	.728	30	
GM Power Box	Model 605 ('78-84)	3/4"-30	.728	30	
	Model 700 ('77 & earlier)	13/16"-36	.812	36	
	Model 700 ('78 & later)	3/4"-30	.728	30	
GM Rack	'79 & later	5/8"-36	.625	36	
	Some Models	3/4"-30	.728	30	
	Corvette ('84 & later)	17mm DD	.670		.570
	Fiero	17mm DD	.670		.570
Ford Box	Manual & Power	3/4"-36	.735	36	
Ford Rack	Mustang & Pinto Manual	9/16"-26	.562	26	
	Mustang & Pinto Power	3/4"-36	.735	36	
	94-Later Mustang	3/4"-V	.740		
Other Manufacturers	Borgeson 55-57 Chevy Conversion	18mm DD	.708		.635
	Borgeson 58-64 Chevy Conversion	17mm DD	.670		.570
	Borgeson Chevy II Nova Conversion	11/16"-36	.687	36	
	Borgeson Corvette Conversion Box	18mm DD	.708		.635
	Borgeson Ford Conversion Boxes	11/16"-36	.687	36	
	Borgeson Mopar Conversion Boxes	11/16"-36	.687	36	
	Heidt's Super Ride Rack	9/16"-26	.562	26	
	Woodward Rack	3/4"-20	.735	20	
	Nissan	11/16"-36	.687	36	
	Jaguar & MGB	3/4"-48	.750	48	
	Unisteer Manual Rack	9/16"-26	.562	26	
	Volkswagen Rabbit Rack	11/16"-40	.687	40	
	VW Rabbit Rack Diesel	3/4"-36	.735	36	

*The 5/8"-36 Chrysler is not interchangeable with 5/8"-36.

SHOP TOUR

Wide Angle View



CNC Production



Saginaw Manual Steering Gear Production



Power Steering Assembly & Testing



Packaging, Shipping & Inventory



GENERAL INFORMATION

Maintenance & Inspection

The steering system must be in perfect operating condition at all times. It should be checked on a regular basis. Components should move freely with no play. If play develops, replace worn parts as necessary. Check all set screws, clamp screws and pins for tightness. Welds are especially difficult to inspect by eye, but look for any visible cracks.



EXPERIENCE COUNTS

WHO ELSE CAN SAY THAT THEY'VE BEEN MAKING QUALITY U-JOINTS SINCE 1914?

STEERING U-JOINTS, SHAFTS & HEAVY DUTY TRUCK ASSEMBLIES

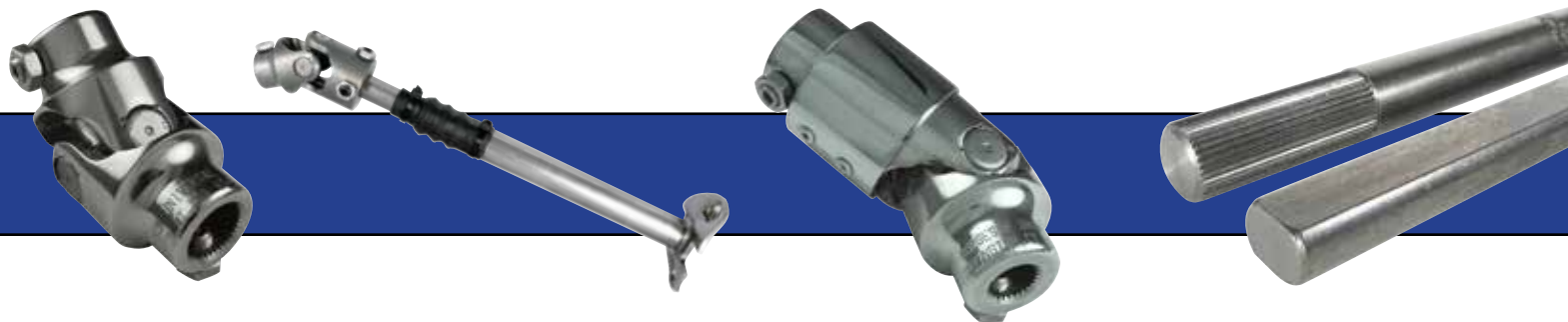

STEERING BOXES, POWER CONVERSION KITS & ACCESSORIES

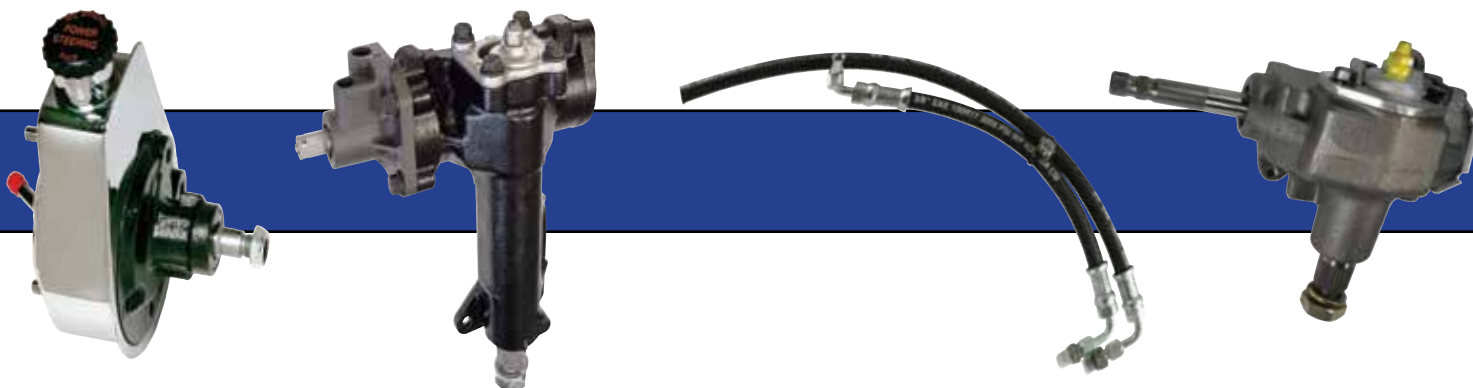

SINCE 1914

THANK YOU. *The success and vitality of Borgeson Universal Company is due to the loyal support of our customers. We here at Borgeson Universal are thankful for your support throughout these many years, and look forward to a continued relationship with you.*



OVER 100 YEARS

BORGESON
Steering You Forward

Learn more about performance steering parts we have.